

9.9 - 12.5 Gb/s Optical Modulator Driver

TGA4954-SL



Key Features and Performance

- Wide Drive Range (3V to 10V)
- Single-Ended Input/Output
- Low Power Dissipation (1.1W @ 6Vo)
- Low Rail Ripple
- 25psec Edge Rates (20/80%)
- Hot-pluggable
- Package Dimensions: 11.4 x 8.9 x 2.0 mm (0.450 x 0.350 x 0.080 inches)

Product Description

The TriQuint TGA4954-SL is part of a series of surface mount modulator drivers suitable for a variety of driver applications and is compatible with Metro MSA standards.

The 4954 consists of two high performance wideband amplifiers combined with off chip circuitry assembled in a surface mount package. A single 4954 placed between the MUX and Optical Modulator provides OEMs with a board level modulator driver surface mount solution.

The 4954 provides Metro and Long Haul designers with system critical features such as: low power dissipation (1.2W at Vo = 6V), low rail ripple, high voltage drive capability at 5V bias (6 V amplitude adjustable to 3 V), low output jitter, and low input drive sensitivity (250mV at Vo = 6V).

The 4954 requires external DC blocks, a low frequency choke, and control circuitry.

Evaluation boards available upon request.

Lead Free & RoHS compliant.

Note: This device is early in the characterization process prior to finalizing all electrical test specifications. Specifications are subject to change without notice.

Primary Applications

- Mach-Zehnder Modulator Driver

Measured Data

Vdd=5V; Id1=65mA; Id2=115mA; Vctrl1=-0.2V; Vctrl2=+0.2V

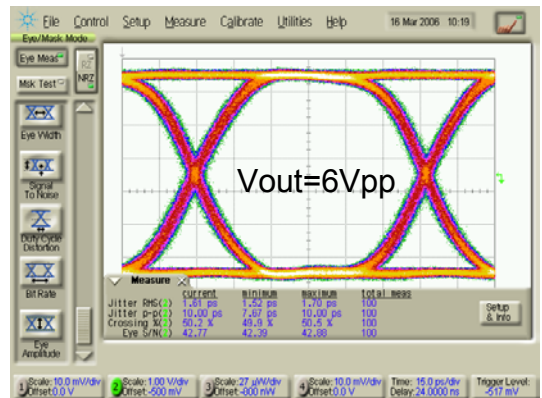
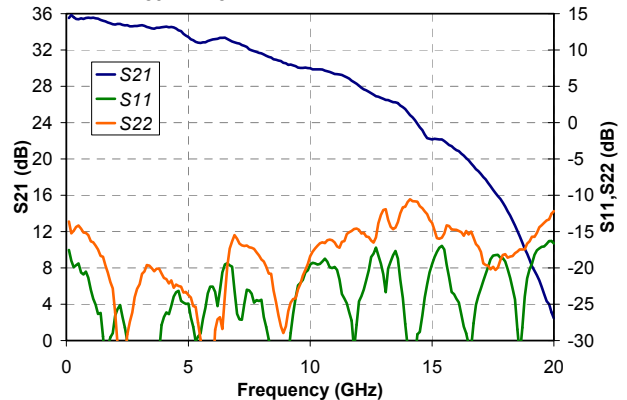

**TABLE I
MAXIMUM RATINGS**

Symbol	Parameter	Value	Notes
V_{D1} V_{D2}	Drain Voltage	8 V	<u>1/</u> <u>2/</u>
V_{G1} V_{G2}	Gate Voltage Range	-3V to 0V	<u>1/</u>
V_{CTRL1} V_{CTRL2}	Control Voltage Range	-3V to V_D	<u>1/</u>
I_{D1} I_{D2}	Drain Supply Current (Quiescent)	200 mA 350 mA	<u>1/</u> <u>2/</u>
$ I_{G1} $ $ I_{G2} $	Gate Supply Current	15 mA	<u>1/</u>
$ I_{CTRL1} $ $ I_{CTRL2} $	Control Supply Current	15 mA	<u>1/</u> <u>5/</u>
P_{IN}	Input Continuous Wave Power	23 dBm	<u>1/</u> <u>2/</u>
V_{IN}	12.5Gb/s PRBS Input Voltage	4 V_{PP}	<u>1/</u> <u>2/</u>
P_D	Power Dissipation	4 W	<u>1/</u> <u>2/</u> <u>3/</u>
T_{CH}	Operating Channel Temperature	150 °C	<u>4/</u>
T_M	Mounting Temperature (10 Seconds)	230 °C	
T_{STG}	Storage Temperature	-65 to 150 °C	

- 1/ These ratings represent the maximum operable values for this device
- 2/ Combinations of supply voltage, supply current, input power, and output power shall not exceed P_D at a package base temperature of 80°C
- 3/ When operated at this bias condition with a baseplate temperature of 80°C, the MTTF is reduced
- 4/ Junction operating temperature will directly affect the device median time to failure (MTTF). For maximum life, it is recommended that junction temperatures be maintained at the lowest possible levels.
- 5/ Assure V_{CTRL1} never exceeds V_{D1} , and V_{CTRL2} never exceeds V_{D2} during bias up and down sequences.

TABLE II
THERMAL INFORMATION

Parameter	Test Conditions	T _{CH} (°C)	R _{θJC} (°C/W)	MTTF (hrs)
R _{θJC} Thermal Resistance (Channel to Backside of Package)	V _{DD} = 5V I _{DD} = 215mA P _{DISS} = 1.08W T _{BASE} = 70°C	92	20.4	>1E6

Note: Thermal transfer is conducted through the bottom of the TGA4954-SL package into the motherboard. The motherboard must be designed to assure adequate thermal transfer to the base plate.

TABLE III
RF CHARACTERIZATION TABLE
 (T_A = 25°C, Nominal)

Parameter	Test Conditions	Min	Typ	Max	Units	Notes
Small Signal Bandwidth			8		GHz	
Saturated Power Bandwidth			12		GHz	
Small Signal Gain	0.1, 2, 4 GHz	28	34		dB	<u>1/</u>
	6 GHz	26	33			
	10 GHz	24	30			
	14 GHz	17	25			
	16 GHz	12	21			
Input Return Loss	0.1, 2, 4, 6, 10, 14, 16 GHz	10	15		dB	<u>1/</u>
Output Return Loss	0.1, 2, 4, 6, 10, 14, 16 GHz	10	15		dB	<u>1/</u>
Noise Figure	3 GHz		2.5		dB	
Small Signal AGC Range	Midband		28		dB	
Saturated Output Power	2, 4, 6, 8 & 10 GHz	24	26.5		dBm	<u>6/ 7/</u>

TABLE III (Continued)
RF CHARACTERIZATION TABLE
(T_A = 25°C, Nominal)

Parameter	Test Conditions	Min	Typ	Max	Units	Notes
Eye Amplitude	V _{D2} = 8.0V	9.0			V _{PP}	<u>2/</u>
	V _{D2} = 6.5V	7.0				
	V _{D2} = 5.5V	6.0				
	V _{D2} = 4.5V	5.5				
	V _{D2} = 4.0V	5.0				
Additive Jitter (RMS)	V _{IN} = 500mV _{PP}		1.2	3.0	psec	<u>5/</u>
	V _{IN} = 800mV _{PP}		1.4	3.0		
Q-Factor	V _{IN} = 250mV _{PP}	25	39		V/V	
	V _{IN} = 500mV _{PP}	25	42			
	V _{IN} = 800mV _{PP}	25	42			
Delta Crossing Percentage	250mV _{PP}			10.0	%	
	800mV _{PP}			8.0		
Delta Eye Amplitude	250mV _{PP}	-0.50	-0.1	0.50	V _{PP}	
	800mV _{PP}	-0.50	0.0	0.50		

Table III Notes:

- 1/ Package RF Bias: V_{DD} = 5V, adjust V_{G1} to achieve I_{D1} = 65mA then adjust V_{G2} to achieve I_{D2} = 115mA, V_{CTRL1} = -0.2V & V_{CTRL2} = +0.2 V
- 2/ V_{IN} = 250mV, Data Rate = 10.7Gb/s, V_{D1} = V_{D2} or greater, V_{CTRL2} and V_{G2} are adjusted for maximum output
- 5/ Computed using RSS Method where $J_{RMS_DUT} = \sqrt{(J_{RMS_TOTAL}^2 - J_{RMS_SOURCE}^2)}$
- 6/ Verified at die level on-wafer probe
- 7/ Power Bias Die Probe: V_{TEE} = 8V, adjust V_G to achieve I_D = 175mA ±5%, V_{CTRL} = +1.5V
- 8/ Value is the difference with the 500mV input measurement. Result is the absolute value.

Note: At the die level, drain bias is applied through the RF output port using a bias tee, voltage is at the DC input to the bias tee

Measured Data

Vdd=5V; Id1=65mA; Id2=115mA; Vctrl1=-0.2V; Vctrl2=+0.2V

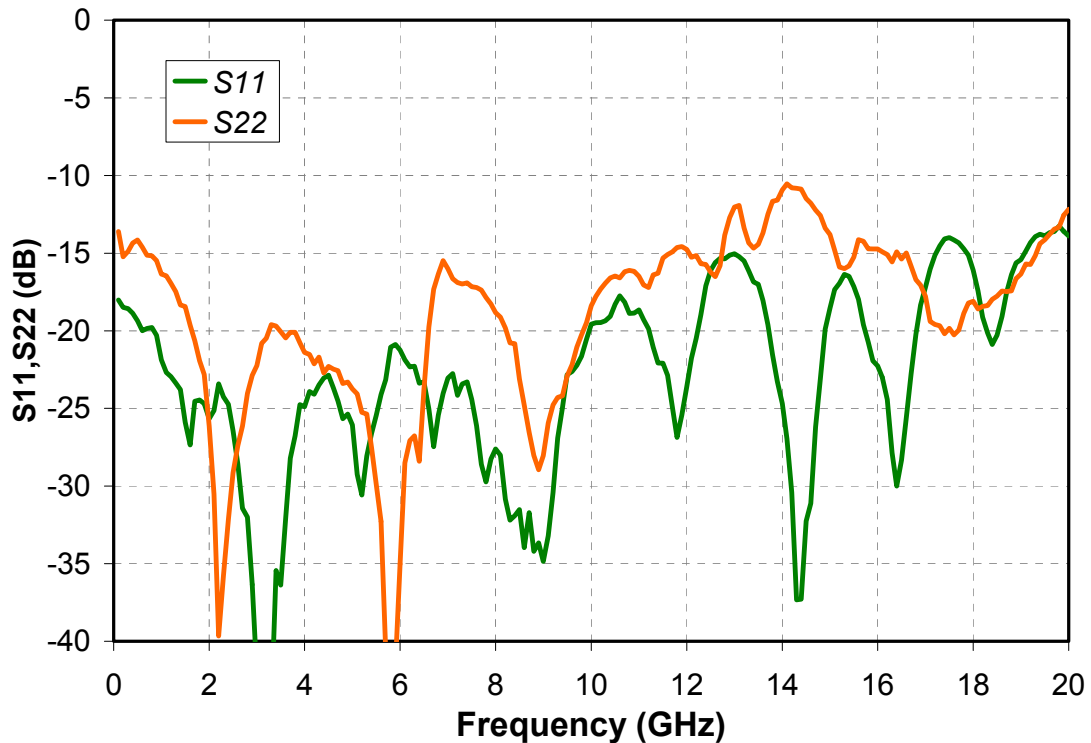
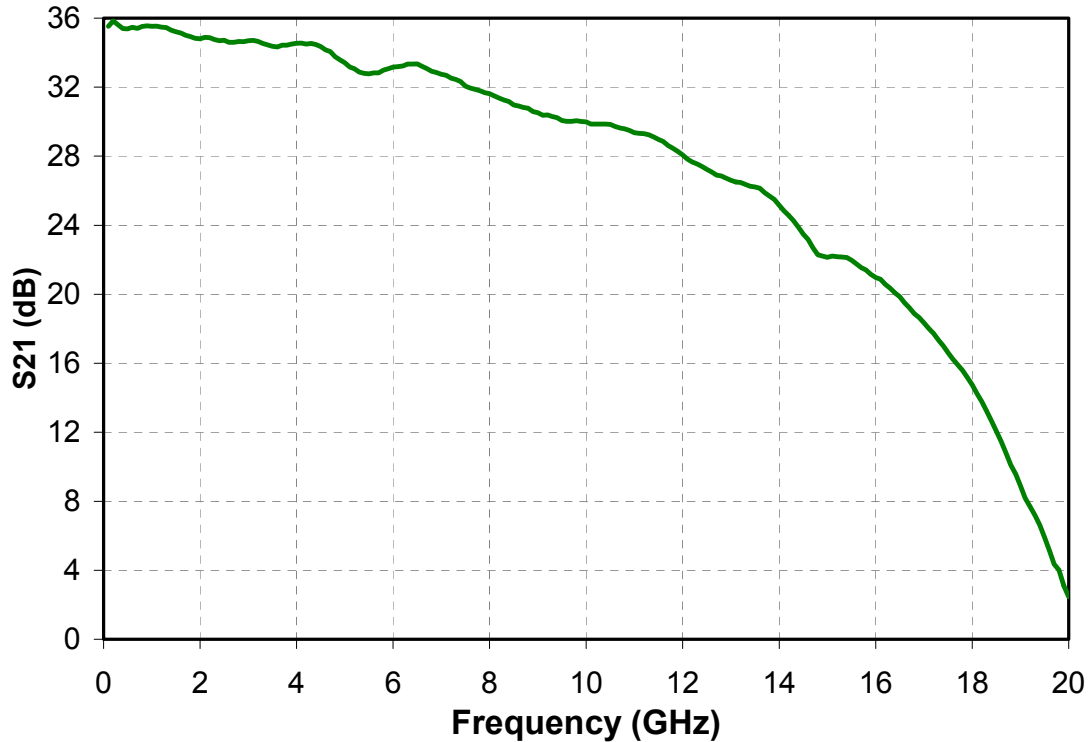

Measured Data

Vdd=5V; Id1=65mA; Vctrl1=-0.2V; Vin=500mVpp; Vo=6Vpp
 Vg2 & Vctrl2 are varied to achieve 6Vo & 50% crossing

9.953Gbps

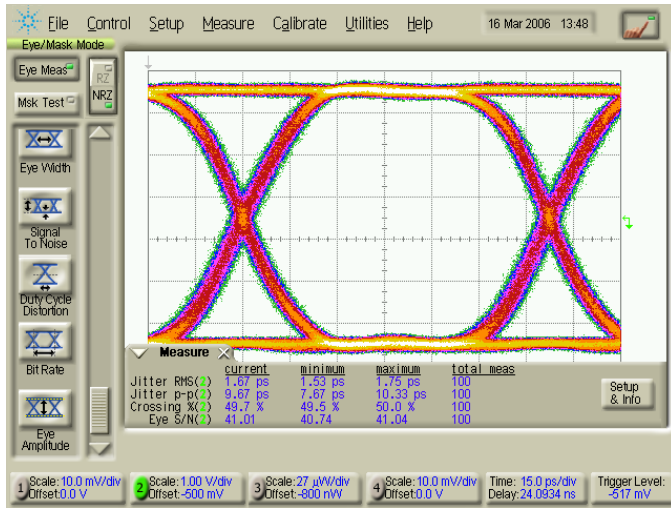

10.7Gbps

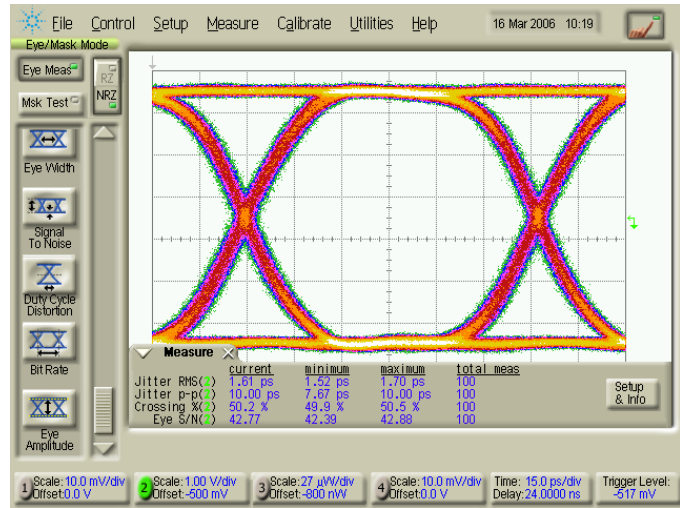

11.3Gbps

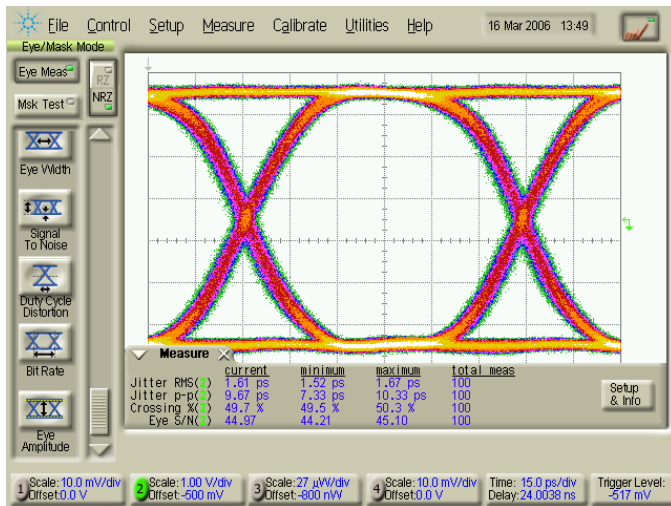

12.5Gbps

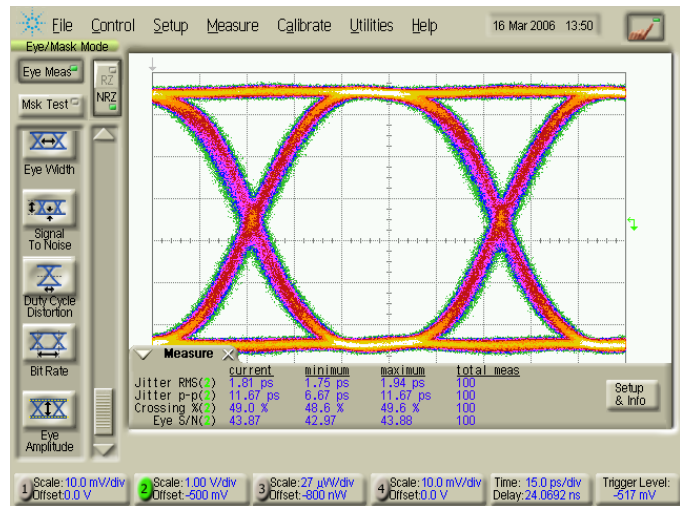

Measured Data

Vdd=5V; Id1=65mA; Vctrl1=-0.2V; Vo=6Vpp; 10.7Gbps
 Vg2 & Vctrl2 are varied to achieve 6Vo & 50% crossing

Vin=250mVpp

Vin=500mVpp

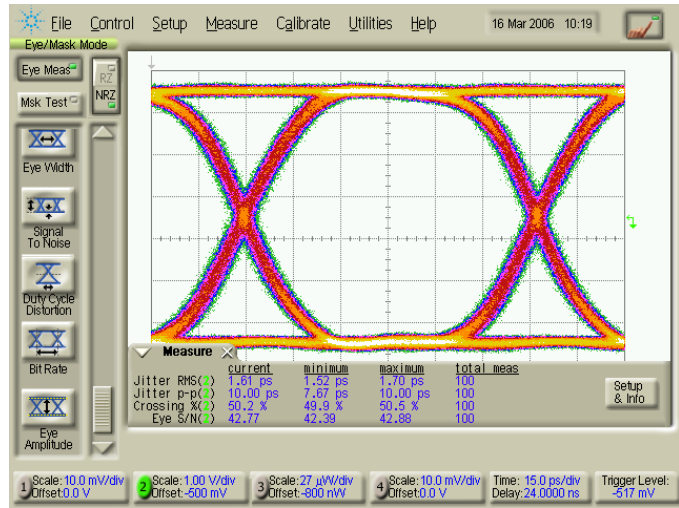
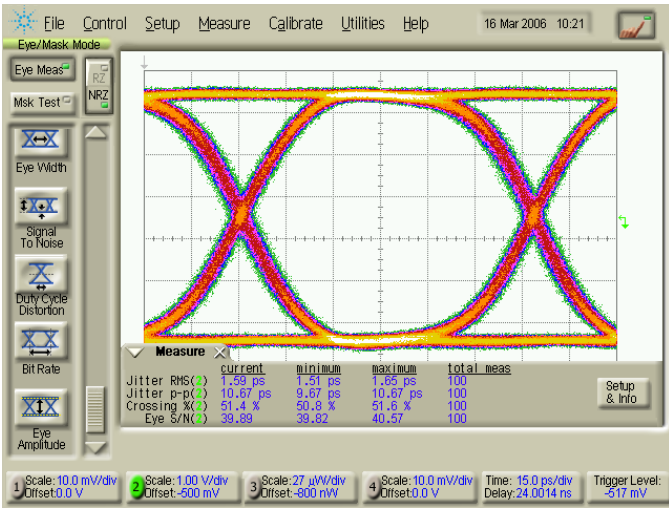

Vin=800mVpp

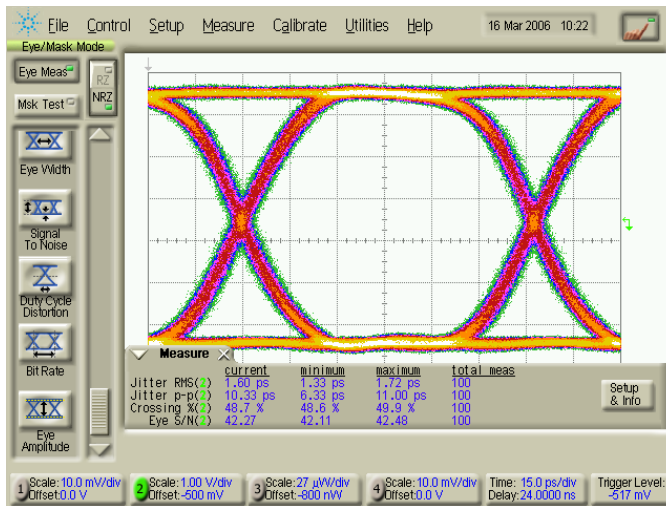

Measured Data

Vdd=5V; Id1=65mA; Vctrl1=-0.2V; Vin=500mVpp; 10.7Gbps
 Vg2 & Vctrl2 are varied to achieve 6Vo & 50% crossing

3Vo

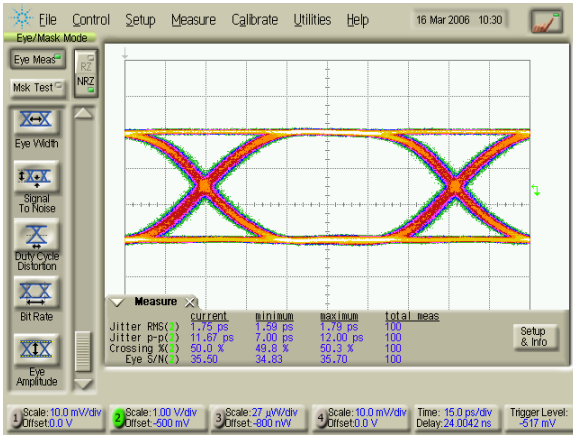

4Vo

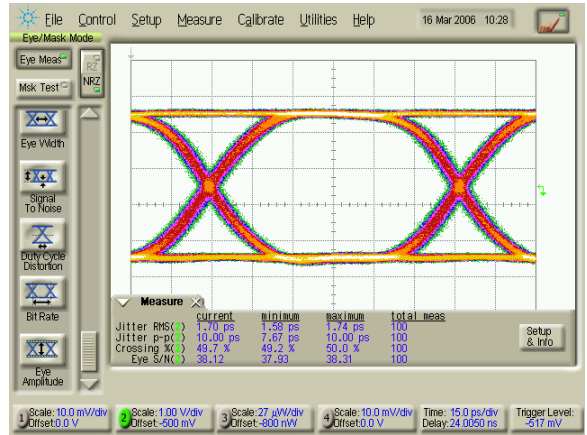

5Vo

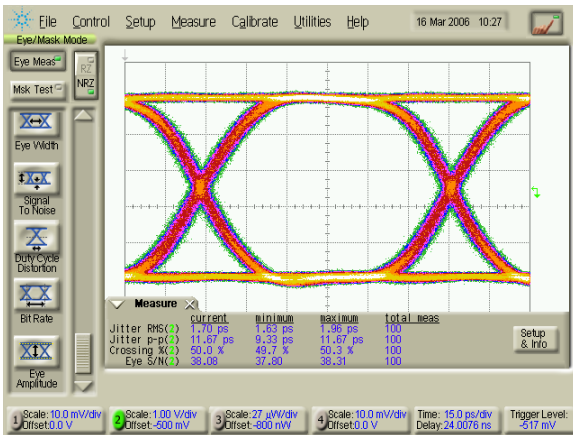

6Vo

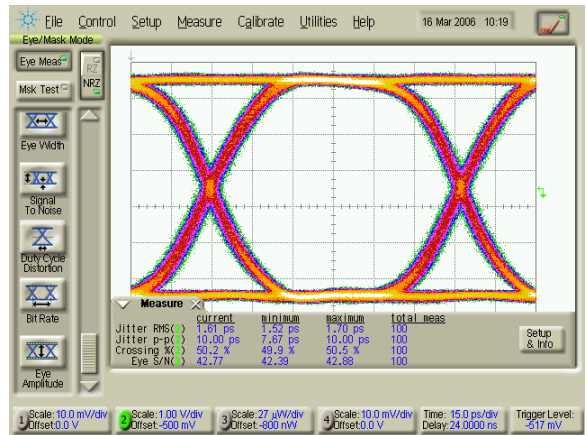

Input

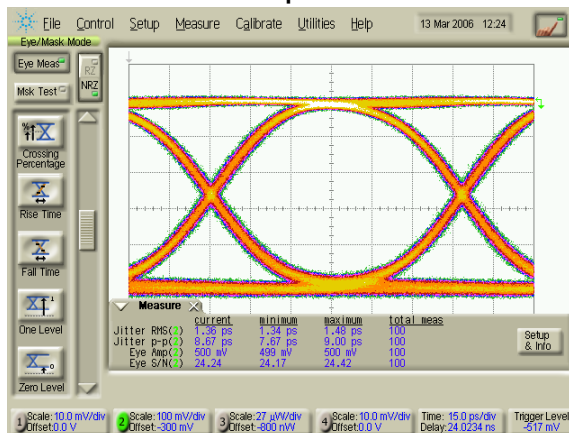

TGA4954 Typical Performance Data Measured in a Test Fixture

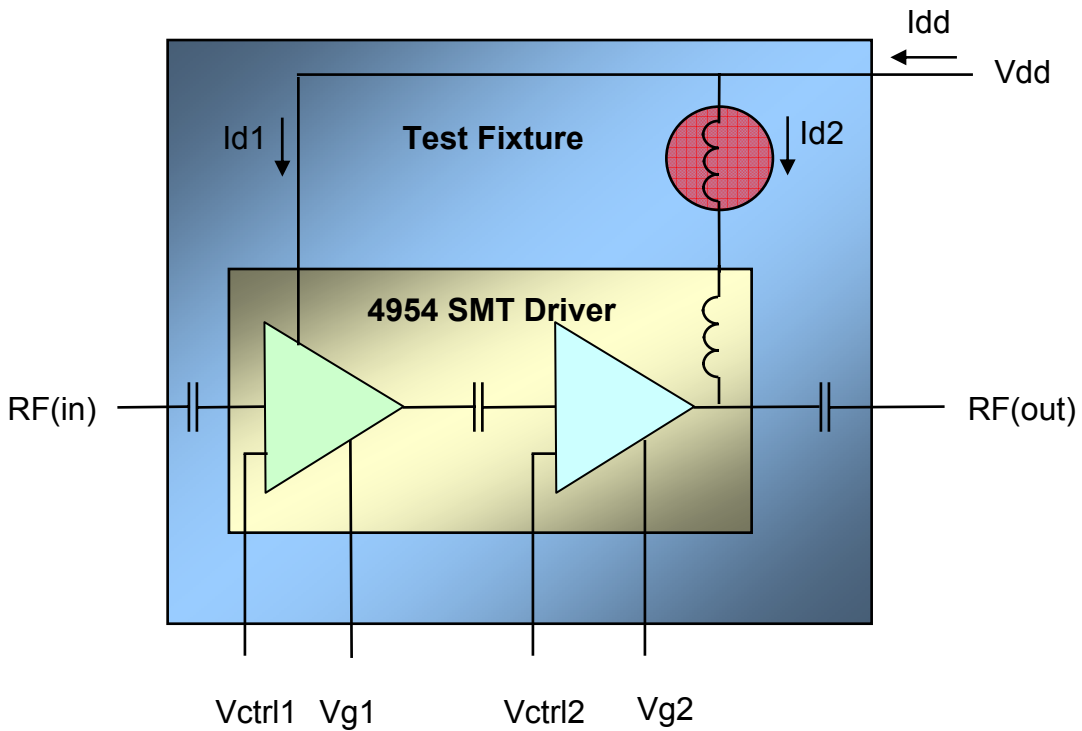

Test Fixture Block Diagram

Production - Initial Alignment - Bias Procedure

Vdd=5V, Vo=6Vamp, CPC=50%

(Hot-Pluggable)

Bias Network Initial Conditions -

Vg1=-1.5V

Vg2=-1.5V

Vctrl1=-0.2V

Vctrl2=+.1V

Vdd=5V

Bias ON

1. Disable the output of MUX
2. Apply Vg1, Vg2, Vctrl1 and Vctrl2 in any sequence.
3. Apply Vdd.
4. Make Vg1 more positive until **Idd=65mA**.
 - This is Id1 (current into the first stage)
 - Typical value for **Vg1 is -0.65V**
5. Make Vg2 more positive until Idd=180mA.
 - This sets Id2 to 115mA.
 - Typical value for Vg2 is -0.55V
6. Enable the output of the MUX.
 - Set Vin=500mV
7. Output Swing Adjust: Adjust Vctrl2 slightly positive to increase output swing or adjust Vctrl2 slightly negative to decrease the output swing.
 - Typical value for **Vctrl2 is +0.22V** for Vo=6V.
8. Crossover Adjust: Adjust Vg2 slightly positive to push the crossover down or adjust Vg2 slightly negative to push the crossover up.
 - Typical value for **Vg2 is -0.57V** to center crossover with Vo=6V.

Bias OFF

1. Remove Vdd.
2. Remove Vg1, Vg2, Vctrl1 and Vctrl2 in any sequence.

Production - Post Alignment - Bias Procedure

Vdd=5V, Vo=6Vamp, CPC=50%

(Hot-Pluggable)

Bias Network Initial Conditions -

Vg1= As found during initial alignment

Vg2=-As found during initial alignment

Vctrl1=-0.2V

Vctrl2=As found during initial alignment

Vdd=5V

Bias ON

1. Mux output can be either Enabled or Disabled
2. Apply Vg1, Vg2, Vctrl1 and Vctrl2 in any sequence.
3. Apply Vdd.
4. Enable the output of the MUX
5. Output Swing Adjust: Adjust Vctrl2 slightly positive to increase output swing or adjust Vctrl2 slightly negative to decrease the output swing.
6. Crossover Adjust: Adjust Vg2 slightly positive to push the crossover down or adjust Vg2 slightly negative to push the crossover up.

Bias OFF

1. Remove Vdd.
2. Remove Vg1, Vg2, Vctrl1 and Vctrl2 in any sequence.

Mechanical Drawing

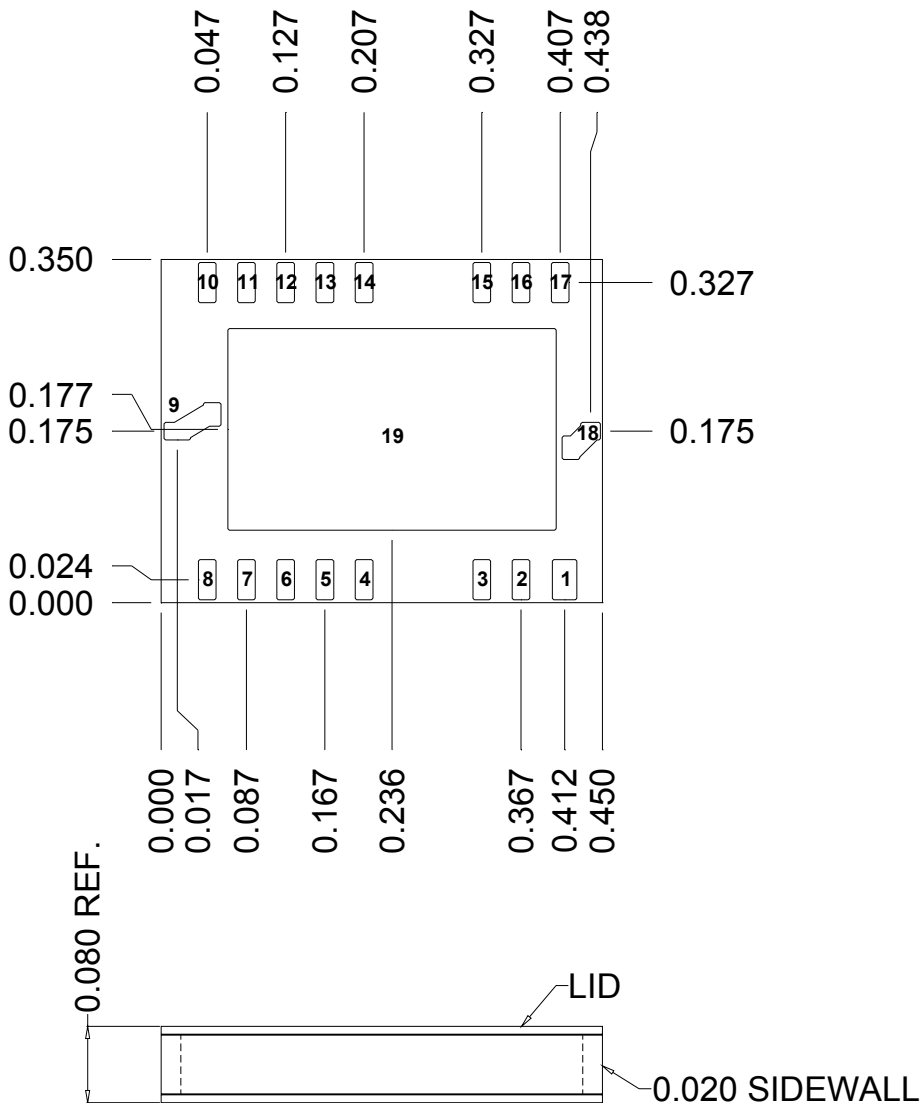

Bond Pad #1	N/C	0.025 x 0.041	Bond Pad #10	N/C	0.018 x 0.041
Bond Pad #2	N/C	0.018 x 0.041	Bond Pad #11	N/C	0.018 x 0.041
Bond Pad #3	Vg1	0.018 x 0.041	Bond Pad #12	Vd2	0.018 x 0.041
Bond Pad #4	N/C	0.018 x 0.041	Bond Pad #13	N/C	0.018 x 0.041
Bond Pad #5	N/C	0.018 x 0.041	Bond Pad #14	Vctrl2	0.018 x 0.041
Bond Pad #6	Vg2	0.018 x 0.041	Bond Pad #15	Vd1	0.018 x 0.041
Bond Pad #7	N/C	0.018 x 0.041	Bond Pad #16	N/C	0.018 x 0.041
Bond Pad #8	N/C	0.018 x 0.041	Bond Pad #17	Vctrl1	0.018 x 0.041
Bond Pad #9	RF Out	0.027 x 0.018	Bond Pad #18	RF In	0.020 x 0.018
			Bond Pad #19	GND	0.335 x 0.206

Application Circuit

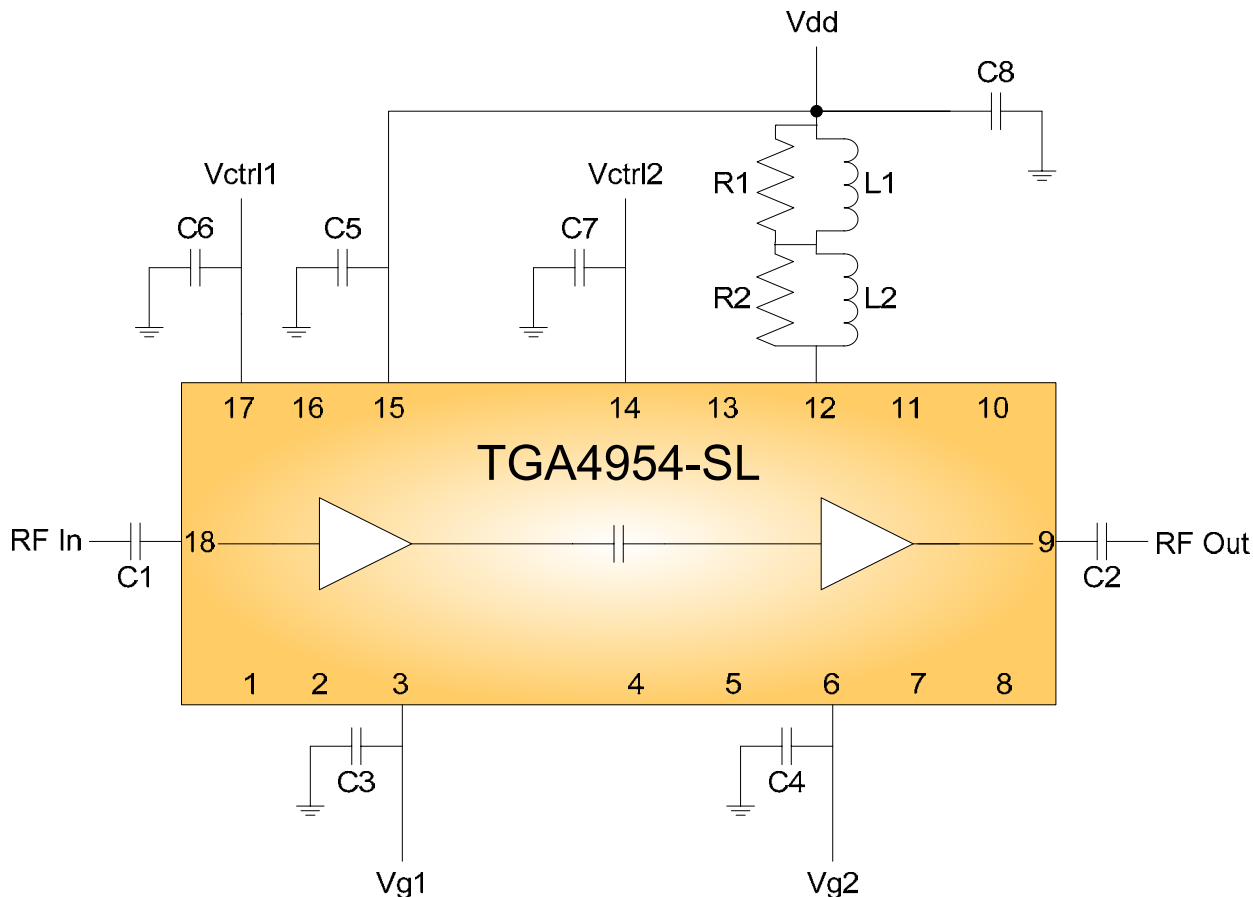

Recommended Components:

DESIGNATOR	DESCRIPTION	MANUFACTURER	PART NUMBER
C1, C2	DC Block, Broadband	Presidio	BB0502X7R104M16VNT9820
C3, C4, C5	10uF Capacitor MLC Ceramic	AVX	0802YC106KAT
C6, C7	0.01 uFCapacitor MLC Ceramic	AVX	0603YC103KAT
C8	10 uF Capacitor Tantalum	AVX	TAJA106K016R
L1	220 uH Inductor	Belfuse	S581-4000-14
L2	330 nH Inductor	Panasonic	ELJ-FAR33MF2
R1, R2	274 Ω Resistor	Panasonic	ERJ-2RKF2740X

Notes:

1. C3 and C4 extend low frequency performance thru 30 KHz. For applications requiring low frequency performance thru 100 kHz, C3 and C4 may be omitted
2. C6 and C7 are power supply decoupling capacitors and may be omitted when driven directly with an op-amp. Impedance looking into VCTRL1 and VCTRL2 is 10kΩ real

Recommended Surface Mount Package Assembly

Proper ESD precautions must be followed while handling packages.

Clean the board with acetone. Rinse with alcohol. Allow the circuit to fully dry.

TriQuint recommends using a conductive solder paste for attachment. Follow solder paste and reflow oven vendors' recommendations when developing a solder reflow profile. Typical solder reflow profiles are listed in the table below.

Hand soldering is not recommended. Solder paste can be applied using a stencil printer or dot placement. The volume of solder paste depends on PCB and component layout and should be well controlled to ensure consistent mechanical and electrical performance. *This package has little tendency to self-align during reflow.*

Clean the assembly with alcohol.

Typical Solder Reflow Profiles

Reflow Profile	SnPb	Pb Free
Ramp-up Rate	3 °C/sec	3 °C/sec
Activation Time and Temperature	60 – 120 sec @ 140 – 160 °C	60 – 180 sec @ 150 – 200 °C
Time above Melting Point	60 – 150 sec	60 – 150 sec
Max Peak Temperature	240 °C	260 °C
Time within 5 °C of Peak Temperature	10 – 20 sec	10 – 20 sec
Ramp-down Rate	4 – 6 °C/sec	4 – 6 °C/sec

Ordering Information

Part	Package Style
TGA4954-SL	Land Grid Array Surface Mount

GaAs MMIC devices are susceptible to damage from Electrostatic Discharge. Proper precautions should be observed during handling, assembly and test.