

# TGS 2442 - for the detection of Carbon Monoxide

## Features:

- \* Low power consumption
- \* High sensitivity/selectivity to carbon monoxide (CO)
- \* Miniature size
- \* Low sensitivity to alcohol vapor
- \* Long life and low cost
- \* Low humidity dependency

## Applications:

- \* CO detectors
- \* Air quality controllers
- \* Indoor parking lot ventilation

**TGS 2442** utilizes a multilayer sensor structure. A glass layer for thermal insulation is printed between a ruthenium oxide (RuO<sub>2</sub>) heater and an alumina substrate. A pair of Au electrodes for the heater are formed on a thermal insulator. The gas sensing layer, which is formed of tin dioxide (SnO<sub>2</sub>), is printed on an electrical insulation layer which covers the heater. A pair of Au electrodes for measuring sensor resistance are formed on the electrical insulator. Activated charcoal is filled between the internal cover and the outer cover for the purpose of reducing the influence of noise gases.

**TGS 2442** displays good selectivity to carbon monoxide, making it ideal for CO monitors. In the presence of CO, the sensor's conductivity increases depending on the gas concentration in the air. A simple pulsed electrical circuit operating on a one second circuit voltage cycle can convert the change in conductivity to an output signal which corresponds to gas concentration.

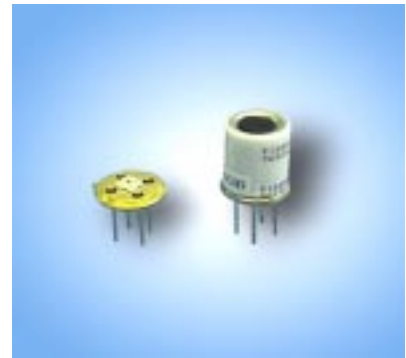

The figure below represents typical sensitivity characteristics, all data having been gathered at standard test conditions (see reverse side of this sheet). The Y-axis is indicated as *sensor resistance ratio* (Rs/Ro) which is defined as follows:

- Rs = Sensor resistance of displayed gases at various concentrations
- Ro = Sensor resistance in 100ppm CO

The figure below represents typical temperature and humidity dependency characteristics. Again, the Y-axis is indicated as *sensor resistance ratio* (Rs/Ro), defined as follows:

- Rs = Sensor resistance at 30ppm, 100ppm and 300ppm of CO at various temperatures and 50%R.H.
- Ro = Sensor resistance at 300ppm of CO at 25°C and 50% R.H.

### Sensitivity Characteristics:

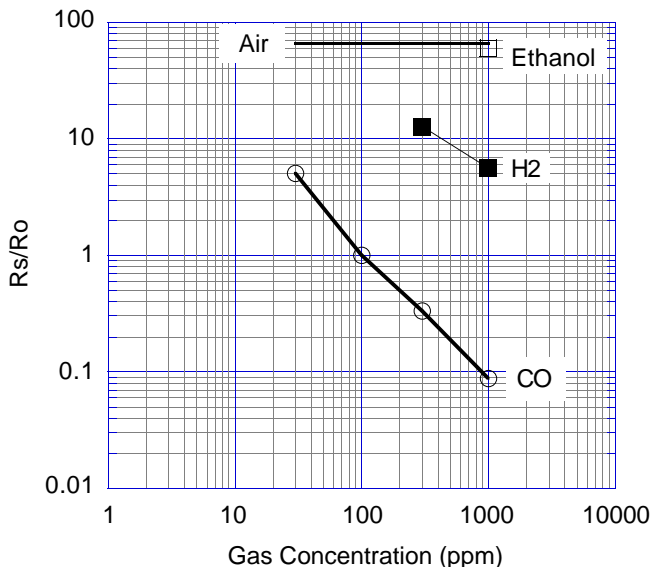

### Temperature/Humidity Dependency:

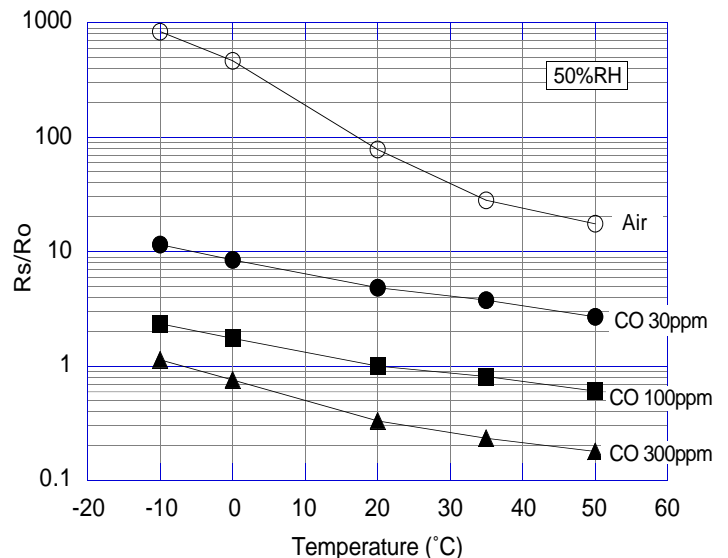

**IMPORTANT NOTE:** OPERATING CONDITIONS IN WHICH FIGARO SENSORS ARE USED WILL VARY WITH EACH CUSTOMER'S SPECIFIC APPLICATIONS. FIGARO STRONGLY RECOMMENDS CONSULTING OUR TECHNICAL STAFF BEFORE DEPLOYING FIGARO SENSORS IN YOUR APPLICATION AND, IN PARTICULAR, WHEN CUSTOMER'S TARGET GASES ARE NOT LISTED HEREIN. FIGARO CANNOT ASSUME ANY RESPONSIBILITY FOR ANY USE OF ITS SENSORS IN A PRODUCT OR APPLICATION FOR WHICH SENSOR HAS NOT BEEN SPECIFICALLY TESTED BY FIGARO.

**Basic Measuring Circuit:**

Circuit voltage (Vc) is applied across the sensing element which has a resistance (Rs) between the sensor's two electrodes (pins No. 2 and No. 3) and a load resistor (RL) connected in series. The sensing element is heated by the heater which is connected to pins No. 1 and No. 4.

**Heating cycle**--The sensor requires application of a 1 second heating cycle which is used in connection with a circuit voltage

cycle of 1 second. Each VH cycle is comprised by 4.8V being applied to the heater for the first 14ms, followed by 0V pulse for the remaining 986ms. The Vc cycle consists of 0V applied for 995ms, followed by 5.0V for 5ms. For achieving optimal sensing characteristics, the sensor's signal should be measured after the midpoint of the 5ms Vc pulse of 5.0V (for reference, see timing chart below).

**NOTE:** Application of a Vc pulse condition is required to prevent possible migration of heater materials into the sensing element material. Under extreme conditions of high humidity and temperature, a constant Vc condition could result in such migration and cause long term drift of Rs to higher values. A 5ms Vc pulse results in significantly less driving force for migration than a constant Vc condition, rendering the possibility of migration negligibly small.

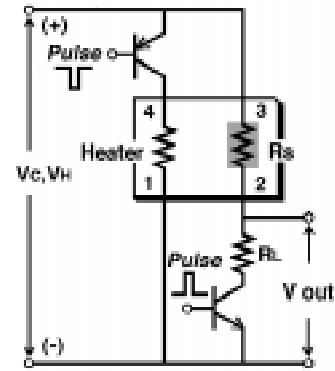
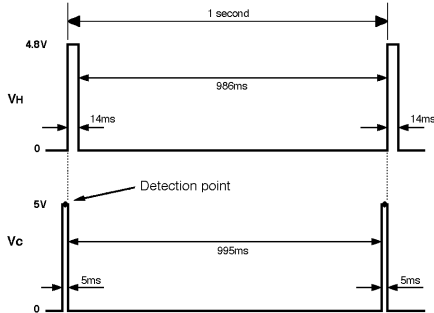

**Structure and Dimensions:**

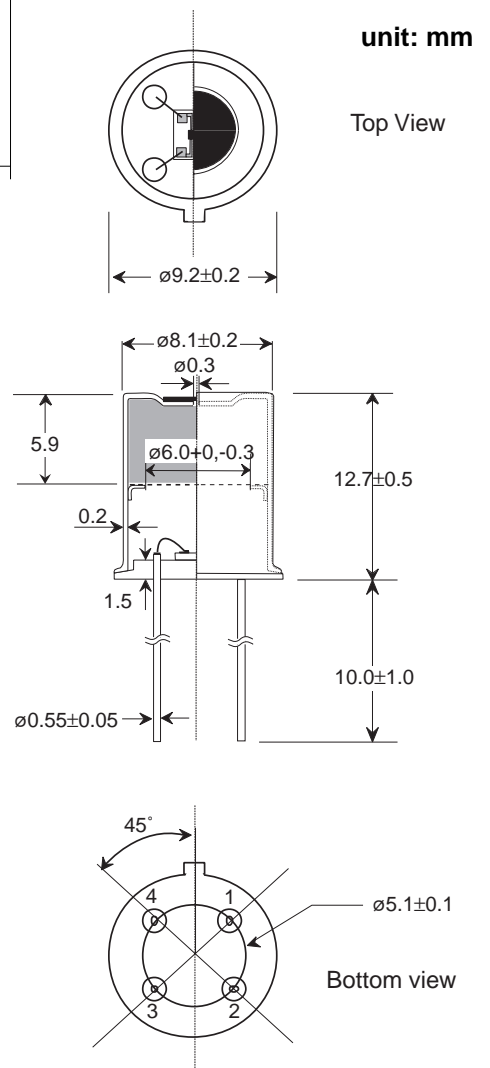

**Preliminary Specifications:**

Model number		TGS 2442	
Sensing element type		M1	
Standard package		TO-5 metal can	
Target gases		Carbon monoxide	
Typical detection range		30 ~ 1000 ppm	
Standard circuit conditions	Heater voltage cycle	VH	VHH=4.8V±0.2V DC, 14ms VHL=0V, 986ms
	Circuit voltage cycle	VC	VC=0V for 995ms, VC=5.0V±0.2V DC for 5ms
	Load resistance	RL	variable (≥10kΩ)
Electrical characteristics under standard test conditions	Heater resistance	RH	17 ± 2.5Ω at room temp.
	Heater current	IH	approx. 203mA(in case of VHH)
	Heater power consumption	PH	approx. 14mW (ave.)
	Sensor resistance	RS	6.81 kΩ ~ 68.1 kΩ in 100ppm of carbon monoxide
	Sensitivity (change ratio of Rs)	β	0.23 ~ 0.49
Standard test conditions	Test gas conditions	Carbon monoxide in air at 20±2°C, 65±5%RH	
	Circuit conditions	Same as Std. Circuit Condition (above)	
	Conditioning period before test	> 2 days (under review)	

Sensor resistance (Rs) is calculated with a measured value of Vout as follows:

$$R_s = \frac{V_{out}}{I} - R_L$$

The value of sensitivity (β) is calculated with two measured values of Rs as follows:

$$\beta = \frac{R_s(CO,300ppm)}{R_s(CO,100ppm)}$$

To facilitate usage of this sensor, TGS2442 is shipped in presorted groupings which have a more narrowly defined range of β:

- Code:** A: 0.23 ~ 0.34      D: 0.32 ~ 0.43  
 B: 0.26 ~ 0.37      E: 0.35 ~ 0.46  
 C: 0.29 ~ 0.40      F: 0.38 ~ 0.49

The above six classification will be further subdivided into the following rankings of Rs values in 100ppm of CO:

- Code:** 1: 6.81 ~ 21.5kΩ      3: 14.7 ~ 46.6kΩ  
 2: 10.0 ~ 31.6kΩ      4: 21.5 ~ 68.1kΩ

**FIGARO**  
 an ISO9001 company



## Technical Information for Carbon Monoxide Sensors

The Figaro TGS2442 sensor is a new type thick film metal oxide semiconductor, screen printed sensor which offers miniaturization and utilizes pulse heating for achieving low power consumption. The TGS2442 displays high selectivity to carbon monoxide together with improved humidity dependency and durability.

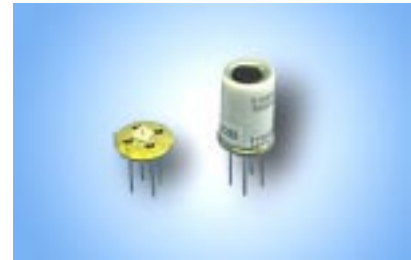

<i>Specifications</i>	<i>Page</i>
Features.....	2
Applications.....	2
Structure.....	2
Basic Measuring Circuit.....	2
Circuit & Operating Conditions.....	3
Mechanical Strength.....	3
Dimensions.....	3
<i>Operation Principle</i> .....	4
<i>Basic Sensitivity Characteristics</i>	
Sensitivity to Various Gases.....	5
Temperature and Humidity Dependency.....	5
Gas Response Pattern.....	6
Heater Voltage Dependency.....	6
Initial Action.....	7
Influence of Unenergized Storage.....	7
<i>Reliability</i>	
Interference Gas Test.....	8
Long-Term Stability.....	9
Corrosion Test.....	9
Variable Ambient Temperature Test.....	9
Humidity Test.....	10
Stability Tests.....	10
<i>Circuit Examples</i>	
Basic Circuit Including Trouble Detection.....	11
Calibration and Temperature Compensation.....	11
<i>Marking and Packaging</i> .....	13
<i>See also Technical Brochure "Technical Information on Usage of TGS Gas Sensors for Explosive/Toxic Gas Alarming".</i>	

**IMPORTANT NOTE:** OPERATING CONDITIONS IN WHICH FIGARO SENSORS ARE USED WILL VARY WITH EACH CUSTOMER'S SPECIFIC APPLICATIONS. FIGARO STRONGLY RECOMMENDS CONSULTING OUR TECHNICAL STAFF BEFORE DEPLOYING FIGARO SENSORS IN YOUR APPLICATION AND, IN PARTICULAR, WHEN CUSTOMER'S TARGET GASES ARE NOT LISTED HEREIN. FIGARO CANNOT ASSUME ANY RESPONSIBILITY FOR ANY USE OF ITS SENSORS IN A PRODUCT OR APPLICATION FOR WHICH SENSOR HAS NOT BEEN SPECIFICALLY TESTED BY FIGARO.

## 1. Specifications

### 1-1 Features

- \* Miniature size and low power consumption
- \* High sensitivity/selectivity to carbon monoxide (CO)
- \* Low sensitivity to alcohol vapor
- \* Reduced influence by various interference gases
- \* Long life and low cost

### 1-2 Applications

- \* Residential and commercial CO detectors
- \* Air quality controllers
- \* Ventilation control for indoor parking garages

### 1-3 Structure

Figure 1 shows the structure of TGS2442. The sensor utilizes a multilayer structure. A glass layer for thermal insulation is printed between a ruthenium oxide ( $\text{RuO}_2$ ) heater and an alumina substrate. A pair of Au electrodes for the heater are formed on a thermal insulator. The gas sensing layer, which is formed of tin dioxide ( $\text{SnO}_2$ ), is printed on an electrical insulation layer which covers the heater. A pair of Pt electrodes for measuring sensor resistance is formed on the electrical insulator. An activated charcoal filter is used for the purpose of reducing the influence of noise gases.

### 1-4 Basic measuring circuit

Figure 2 shows the basic measuring circuit of the TGS2442. Circuit voltage ( $V_c$ ) is applied across the sensing element which has a resistance ( $R_s$ ) between the sensor's two electrodes (pins No. 2 and No. 3) and a load resistor ( $R_L$ ) connected in series. The sensing element is heated by the heater which is connected to pins No. 1 and No. 4.

The sensor requires application of a 1 second heating cycle which is used in connection with a circuit voltage cycle of 1 second. Each  $V_H$  cycle is comprised by 4.8V being applied to the heater for the first 14ms, followed by 0V for the remaining 986ms. The  $V_c$  cycle consists of 0V applied for 995ms, followed by 5.0V for 5ms. For achieving optimal sensing characteristics, the sensor's signal should be measured after the midpoint of the 5ms  $V_c$  pulse of 5.0V (for illustration, see the timing chart in Fig. 3).

**NOTE:** Application of a  $V_c$  pulse condition is required to prevent possible migration of heater materials into the sensing element material. Under extreme conditions of high humidity and temperature, a constant  $V_c$  condition could result in such migration and cause long term drift of  $R_s$  to higher values. A 5ms  $V_c$  pulse results in significantly less driving force for migration than a constant  $V_c$  condition, rendering the possibility of migration negligibly small.

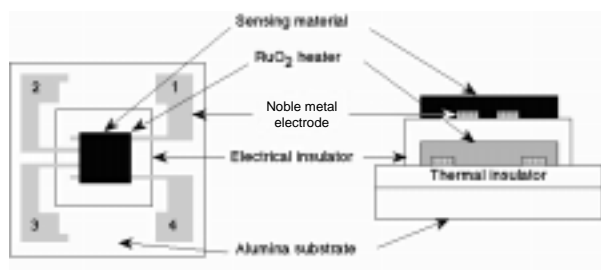
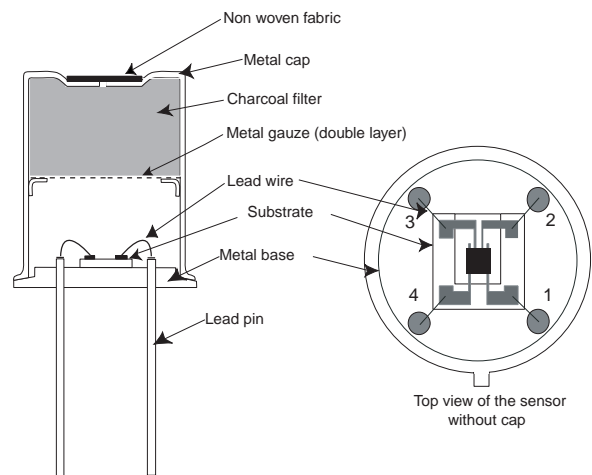

Figure 1 - Sensor structure

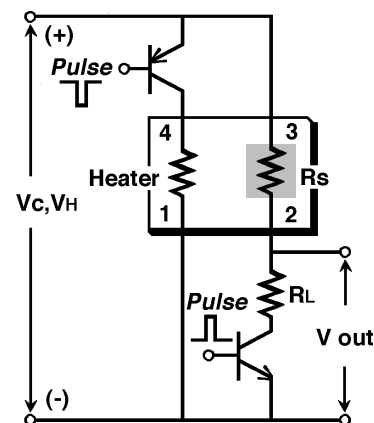

Figure 2 - Basic measuring circuit (including equivalent circuit)

1-5 Circuit & operating conditions

The following conditions should be maintained to ensure stable sensor performance:

Model number		TGS 2442
Sensing element type		M1
Standard package		TO-5 metal can
Target gases		Carbon monoxide
Typical detection range		30 ~ 1000 ppm
Standard circuit conditions	Heater voltage cycle	V <sub>H</sub> V <sub>HH</sub> =4.8V±0.2V DC, 14ms V <sub>HL</sub> =0V, 986ms
	Circuit voltage cycle	V <sub>C</sub> V <sub>C</sub> =0V for 995ms, V <sub>C</sub> =5.0V±0.2V DC for 5ms
	Load resistance	R <sub>L</sub> variable (≥10kΩ)
Electrical characteristics under standard test conditions	Heater resistance	R <sub>H</sub> 17 ± 2.5Ω at room temp.
	Heater current	I <sub>H</sub> approx. 203mA(in case of V <sub>HH</sub> )
	Heater power consumption	P <sub>H</sub> approx. 14mW (ave.)
	Sensor resistance	R <sub>S</sub> 6.81 kΩ ~ 68.1 kΩ in 100ppm of carbon monoxide
	Sensitivity (change ratio of R <sub>S</sub> )	β 0.23 ~ 0.49
Standard test conditions	Test gas conditions	Carbon monoxide in air at 20±2°C, 65±5%RH
	Circuit conditions	Same as Std. Circuit Condition (above)
	Conditioning period before test	> 2 days (under review)

Formula for calculation of sensor resistance:

$$R_s = \frac{V_c \times R_L}{V_{out}} - R_L$$

Sensitivity (change ratio of R<sub>S</sub>) is calculated with two measured values of R<sub>S</sub> as follows:

$$\beta = \frac{R_s(CO,300ppm)}{R_s(CO,100ppm)}$$

To facilitate usage of this sensor, TGS2442 is shipped in presorted groupings which have a more narrowly defined range of β:

- Code:** A: 0.23~0.34      D: 0.32 ~ 0.43  
 B: 0.26 ~ 0.37      E: 0.35 ~ 0.46  
 C: 0.29 ~ 0.40      F: 0.38 ~ 0.49

The above six classification will be further subdivided into the following rankings of R<sub>S</sub> values in 100ppm of CO:

- Code:** 1: 6.81 ~ 21.5kΩ    3: 14.7 ~ 46.6kΩ  
 2: 10.0 ~ 31.6kΩ    4: 21.5 ~ 68.1kΩ

1-6 Mechanical Strength

The sensor shall have no abnormal findings in its structure and shall satisfy the above electrical specifications after the following performance tests:

**Withstand Force** - withstand force > 5kg in each direction (pin from base)

**Vibration** - frequency--10-500Hz (equiv. to 10G), duration-6 hours, x-y-z direction

**Shock** - acceleration-100G, repeat 5 times

1-7 Dimensions (see Fig. 4)

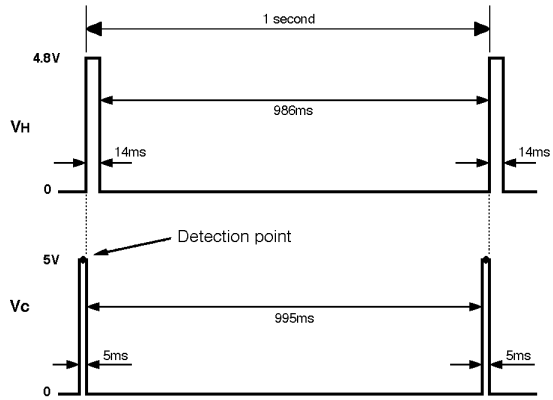

Figure 3 - Circuit voltage and heater voltage cycles

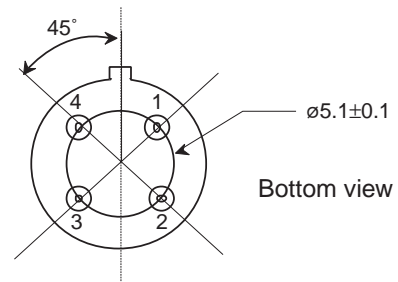
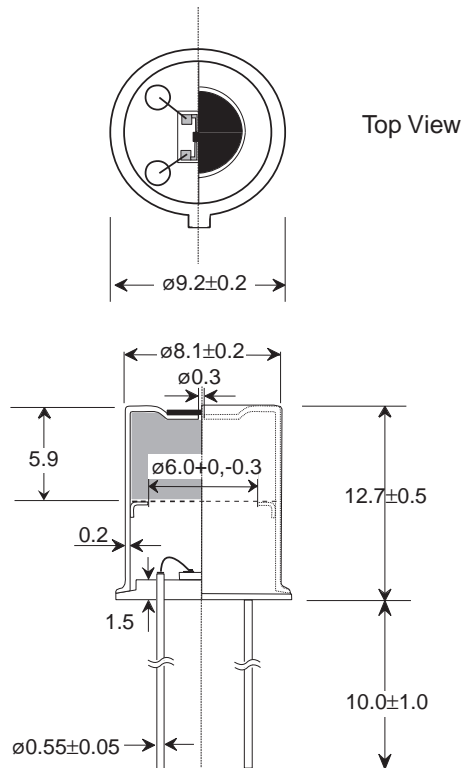

Figure 4 - Dimensions

## TECHNICAL INFORMATION FOR TGS2442

### 2. Operation Principle

The optimum conditions of sensitivity and selectivity to CO of the TGS2442 occurs at sensor temperatures less than 100°C. However, at these lower temperatures, the sensing element may be influenced by humidity and other contaminants, so the sensing element requires periodic heat cleaning at more than 300°C. As a result, the TGS2442 is pulse heated to achieve optimal sensing characteristics at low temperatures.

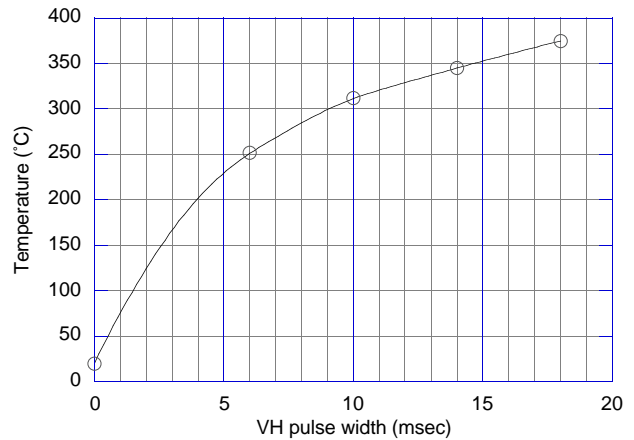

Figure 5 - Relationship of sensor temperature and VH pulse width (VH=4.8V, RH=17Ω)

Figure 6a shows the pattern of resistance change ratio ( $R_s/R_o$ ) for various CO concentrations which occurs during the 1 second heater pulse cycle, starting with application of the 14ms VH pulse. During the VH pulse, initially sensor resistance drops quickly and then returns to a higher value. After the VH pulse concludes and the sensing element's surface temperature begins to decrease (Fig. 6b), sensor resistance reaches to its maximum value and then begins to decline. Note that the shape of the response pattern varies according to the concentration of CO - higher CO concentrations result in a minimum  $R_s/R_o$  value which occurs more quickly and has a lower value. In addition, shortly after the VH pulse, the  $R_s/R_o$  value also trends downwards at a greater rate for higher CO concentrations after reaching its maximum value.

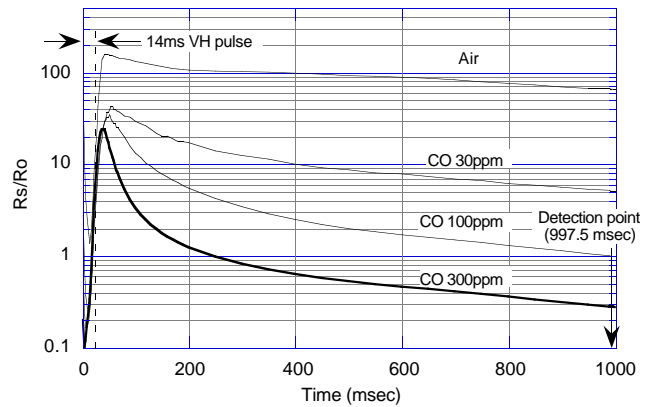

Figure 6a - Sensitivity characteristics during the VH pulse cycle (Ro = Rs in 100ppm CO at 997.5ms of VH cycle)

A signal detection point of 997.5ms into the VH pulse cycle (*ref. timing chart in Fig. 3*) is used to obtain the optimum combination of gas sensitivity performance and minimized ambient humidity effect.

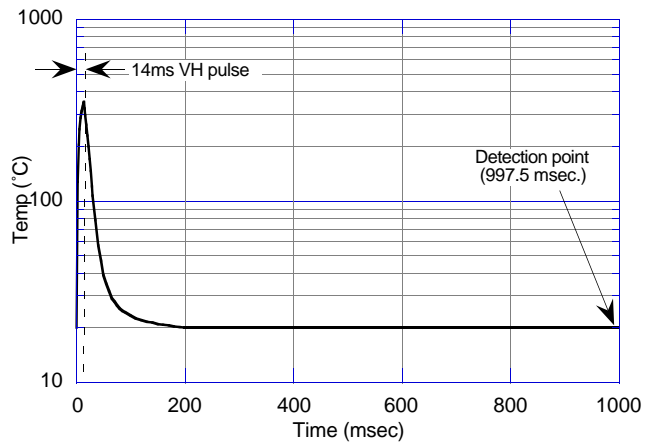

Figure 6b - Surface temperature of sensing element during VH pulse cycle (0msec = start of VH pulse cycle)

### 3. Basic Sensitivity Characteristics

#### 3-1 Sensitivity to various gases

Figure 7 shows the sensor's relative sensitivity to various gases. The Y-axis shows the ratio of sensor resistance in various gases ( $R_s$ ) to the sensor resistance in 100ppm of CO ( $R_o$ ).

As shown by Figure 7, TGS2442 shows very good sensitivity to CO since the sensitivity curve to CO shows a sharp drop in sensor resistance as CO concentration increases. In comparison, sensitivity to ethanol ( $C_2H_5OH$ ) is very low as evidenced by the relatively flat slope of its sensitivity curve and high resistance values.

The amount of CO generated by cigarette smoke is roughly equivalent to 20ppm of CO when 10 cigarettes are smoked in a room of roughly 24 cubic meters in size. As a result, the influence of cigarette smoke itself would not be sufficient to cause the sensor to generate an alarm for residential detectors using TGS2442 which are normally calibrated to alarm at 100ppm of CO.

#### 3-2 Temperature and humidity dependency

Figure 8a shows the temperature dependency of TGS2442. The Y-axis shows the ratio of sensor resistance for various CO concentrations under various temperature conditions ( $R_s$ ) to the sensor resistance in 100ppm of CO at 50%RH ( $R_o$ ).

Figure 8b shows the humidity dependency of TGS2442. The Y-axis shows the ratio of sensor resistance for various CO concentrations under various relative humidity conditions ( $R_s$ ) to the sensor resistance in 100ppm of CO at 20°C.

An inexpensive way to compensate for temperature dependency to a certain extent would be to incorporate a thermistor in the detection circuit (*please refer to Section 5-2*).

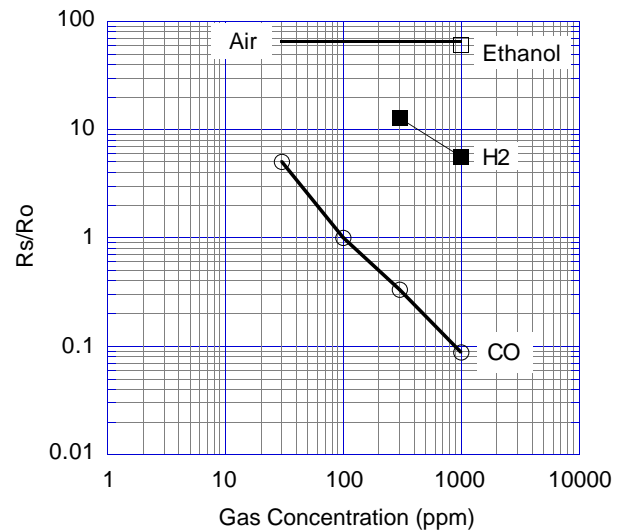

Figure 7 - Sensitivity to various gases  
( $R_o = R_s$  in 100ppm of CO)

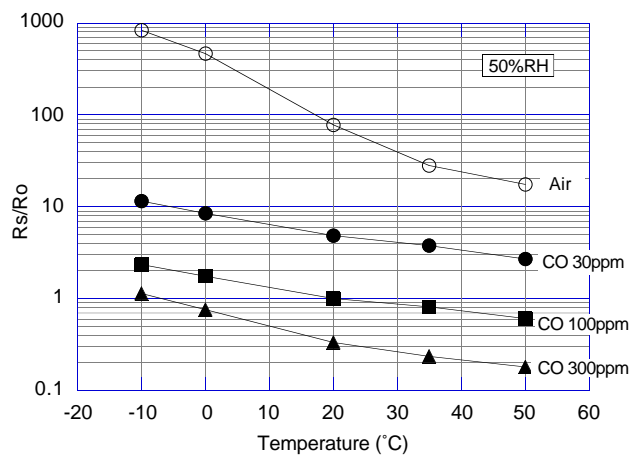

Figure 8a - Temperature dependency at 50%RH  
( $R_o = R_s$  in 100ppm of CO at 20°C)

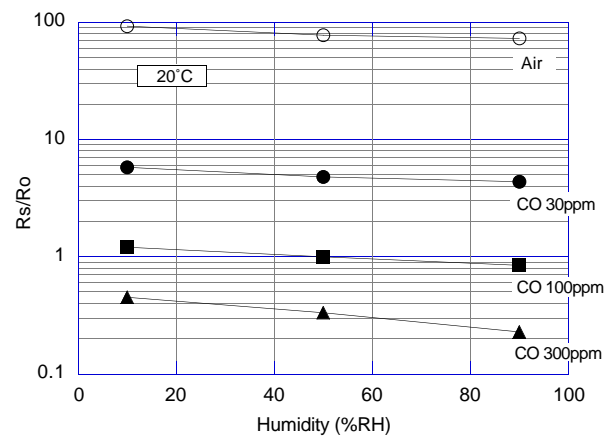

Figure 8b - Humidity dependency at 20°C  
( $R_o = R_s$  in 100ppm of CO at 50%RH)



## TECHNICAL INFORMATION FOR TGS2442

### 3-3 Gas response pattern

The response pattern of the TGS2442 sensor is similar to that of a constant  $V_H$  sensor since data acquisition is carried out once every second during operation. Figure 9 shows the pattern of the output signal when the sensor is placed into 70, 150, and 400ppm of CO and then returned to normal air. The response time to 90% of the saturated signal level is roughly 3.3 minutes and the recovery of the sensor to 90% of the base level is within 10 minutes. This data demonstrates that TGS2442 possesses sufficient response speed for meeting UL requirements for CO detectors.

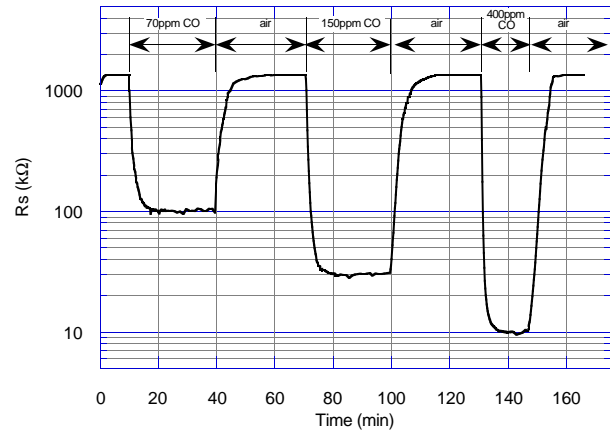

Figure 9 - TGS2442 response pattern in 70, 150, and 400ppm CO

### 3-4 Heater voltage dependency

The TGS2442 should be used with a heater voltage of  $4.8 \pm 0.2V$ . Although at the detection point the sensor's temperature is close to room temperature, its gas sensing characteristics are affected by heater voltage as can be seen in Figure 10. At lower heater voltage, the  $R_s/R_o$  decreases and the difference in sensitivity between CO concentrations narrows. If heater voltages is higher, sensor resistance increases.

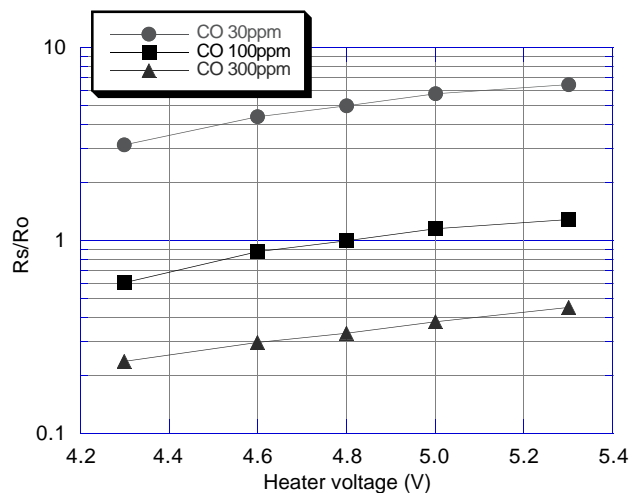

Figure 10 - Heater voltage dependency  
( $R_o = R_s$  at 100ppm of CO and  $V_H=4.8V$ )



## TECHNICAL INFORMATION FOR TGS2442

### 3-5 Initial action

Figure 11 shows the initial action of the sensor's resistance. For purposes of this test, the sensor was stored unenergized in normal air for 40 days after which it was energized in clean air.

After energizing, the sensor's resistance reaches to 90% of its final value in less than one minute, an alarm delay circuit should be incorporated into detectors using TGS2442 to prevent activation of an alarm during this period.

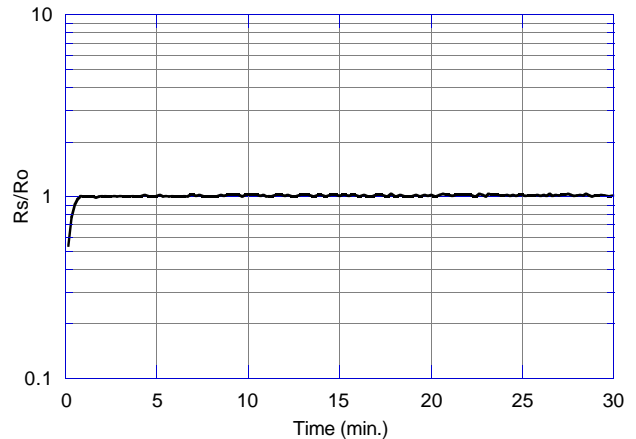

Figure 11 - Initial action  
( $R_o = R_s$  after 20 minutes of energizing)

### 3-6 Influence of unenergized storage

Figure 12 shows the influence of unenergized storage on sensor resistance. Sensors were stored unenergized in normal air for 30 days after which they were energized. The Y-axis represents the ratio of sensor resistance in various concentrations of CO after the unenergized period ( $R_s$ ) to the resistance in 100ppm of CO after energizing at the rated voltage for 4 days ( $R_o$ ).

This chart shows that after energizing, unlike the sensor resistance in clean air (as shown in Fig. 11), resistance in CO first decreases slightly and then returns to a stable level, demonstrating the need for adhering to the recommended preheating period prior to calibration.

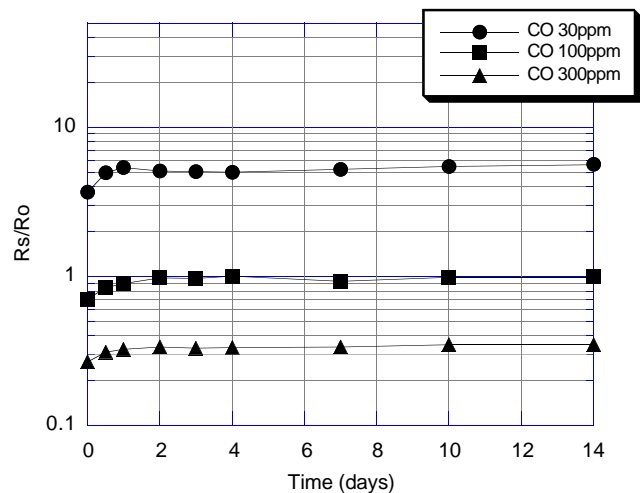

Figure 12 - Time dependency  
( $R_o = R_s$  in 100ppm of CO after 4 days,  $n=20$ )

## TECHNICAL INFORMATION FOR TGS2442

### 4. Reliability

Tests conducted in this section demonstrate that TGS2442 can meet the requirements of various testing standards without incurring adverse long term effects from such tests.

#### 4-1 Interference gas test

Figure 13 shows the results of testing the TGS2442 sensor for durability against various interference gases specified by GRI Test Protocol 1. The test was conducted by exposing the sensor to each gas shown in Fig. 13 (starting with CO 100ppm) for two hours, then removing the sensor to fresh air for just under one hour, and followed by inserting the sensor into the next test gas. This procedure was repeated for the full range of gases shown in Fig. 13.

Because the sensor is exposed to each of the test gases consecutively, to some small extent the effect of the previous test gas may affect subsequent tests for a short period. However, despite the short-term effects of such gases remaining after exposure, the sensor still shows significantly less sensitivity to each test gas when compared to 100ppm of CO, and CO sensitivity remains unaffected.

Figures 14 and 15 show data from tests conducted using interference gases listed in the UL2034 standard for Selectivity Test (Sec. 38) which are deemed to represent air contaminants likely to be found in the vicinity of an installed CO detector. Data for Figure 14 was collected by exposing samples in each of the test gases for a period of two hours as required by the UL standard. Sensor resistance at both the initial point and at the conclusion of test gas exposure was recorded. When compared to the sensor's measured resistance in 100ppm of CO ( $R_o$ ), in all cases the resistance in test gas remained at more than 40 times that of resistance in 100ppm of CO, showing the sensor to have negligible influence by these gases.

Figure 15 demonstrates that sensor subjected to the interference gas tests do not change their characteristics after exposure to these gases. Samples subjected to the interference gas test were compared to reference samples (not subjected to the interference gas tests). Over a two week period, when not undergoing gas test, all samples were energized in fresh air under standard circuit conditions.

This data suggests that TGS2442 shows good durability against every gas used in GRI Test Protocol 1 and meets the requirements of UL2034.

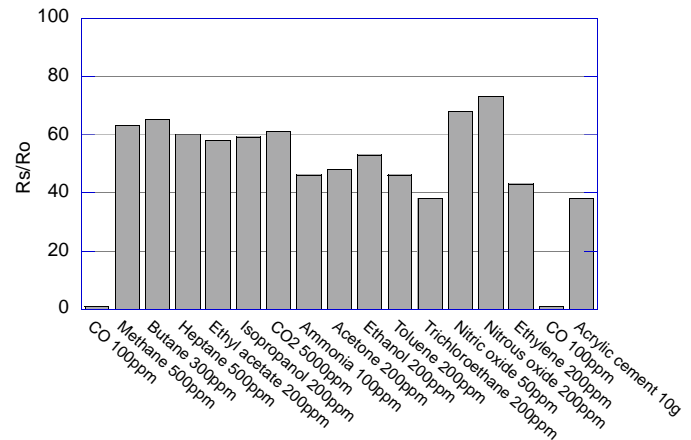

Fig. 13 - Effects of interference gases (GRI Test Protocol 1)  
( $R_o = R_s$  in CO 100ppm)

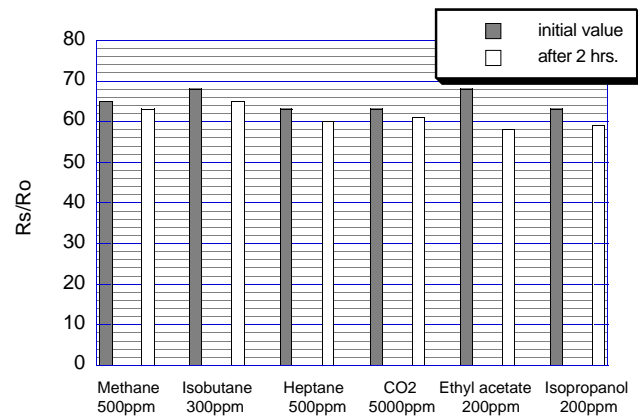

Figure 14 - Selectivity test (UL2034, Sec. 38)  
( $R_o = R_s$  in CO 100ppm)

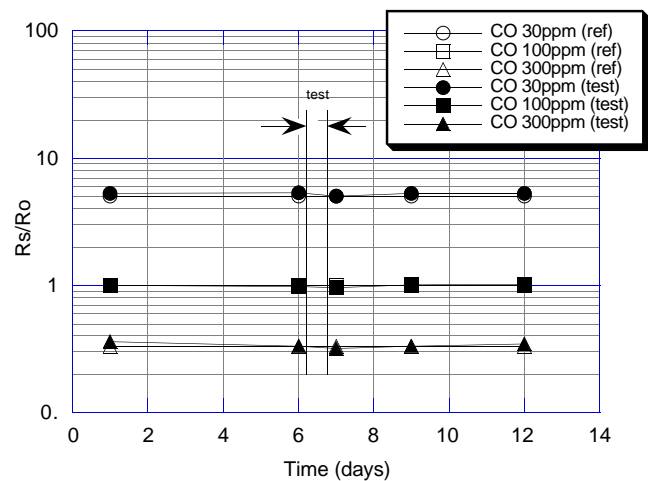

Figure 15 - Stability of sensors subjected to selectivity test  
( $R_o = R_s$  in CO 100ppm on Day 6)

## TECHNICAL INFORMATION FOR TGS2442

### 4-2 Long-term stability

Figure 16 shows long-term stability data for TGS2442. Test samples were energized in normal air and under standard circuit conditions. Measurement for confirming sensor characteristics was conducted under standard test conditions (20°C, 65%RH). The initial value was measured after four days of energizing in normal air at the rated voltage. The Y-axis shows the ratio between measured sensor resistance and the initial (Day 4) resistance value, each in 100ppm of CO. Additional data will be published as it becomes available.

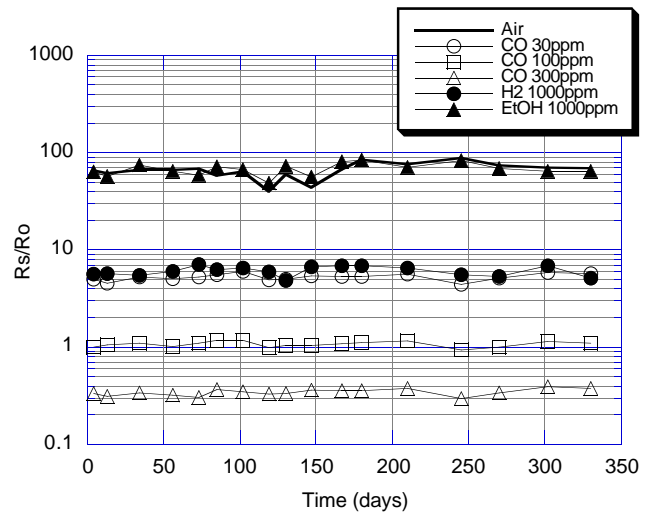

Figure 16 - Long term stability  
(Ro = Rs in 100ppm of CO at Day 4)

### 4-3 Corrosion test

To demonstrate the durability of TGS2442 against corrosion, samples were subjected to test conditions called for by UL2034, Sec. 57-Corrosion Test. Over a three week period, a mixture of 100ppb of H<sub>2</sub>S, 20ppb of Cl<sub>2</sub>, and 200ppb of NO<sub>2</sub> was supplied to the sensor at a rate sufficient to achieve an air exchange of 5 times per hour. When compared to reference samples not subjected to these corrosive gases, no significant difference can be noticed.

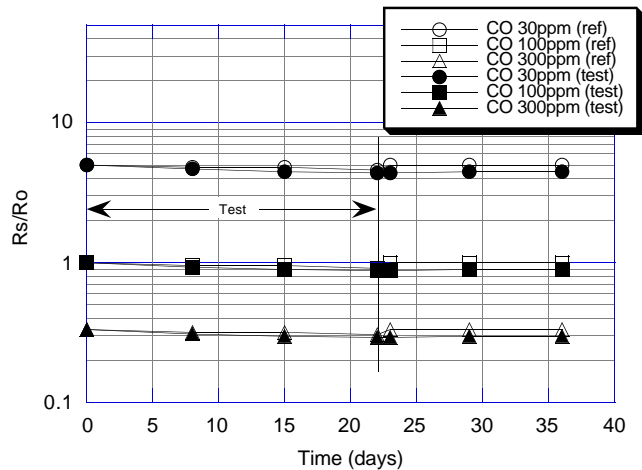

Figure 17 - Durability against corrosion  
(Ro = Rs in 100ppm of CO at Day 2)

### 4-4 Variable ambient temperature test

To show the ability of TGS2442 to withstand the effects of high and low temperatures representative of shipping and storage, the sensor was subjected to the test conditions of UL2034 Sec. 44.2-Effect of Shipping and Storage. Unenergized test samples were subjected to 70°C for 24 hours, allowed to cool to room temperature for 1 hour, subjected to -40°C for 3 hours, and then allowed to warm up to room temperature for 3 hours. When compared to reference samples not subjected to these temperature extremes, no significant difference can be noticed.

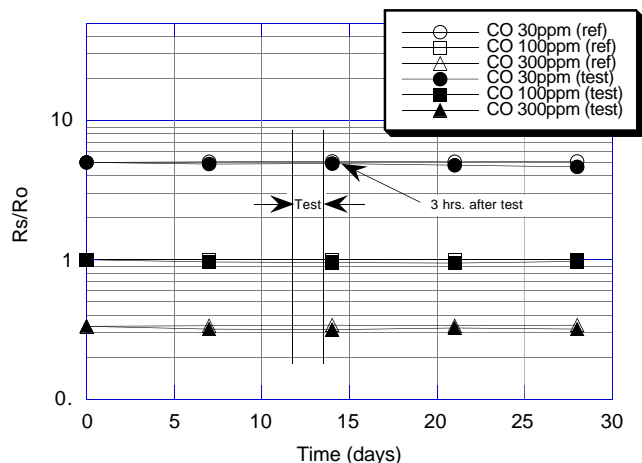

Figure 18 - Variable ambient temperature test  
(Ro = Rs in 100ppm of CO at Day 0)

# TECHNICAL INFORMATION FOR TGS2442

## 4-5 Humidity test

Figure 19 shows the comparison of reference sensors to those energized and exposed in an atmosphere of 52°C and 95% RH for a period of 168 hours, returned to normal air for 2 days, then followed by 168 hours in 20°C/15%RH as required by UL2034 Sec. 46A.1-Humidity Test. As the test measurements taken after the conclusion of the Humidity Test demonstrate, sensors subjected to the test show influence by humidity, but the sensor quickly returns to its normal value.

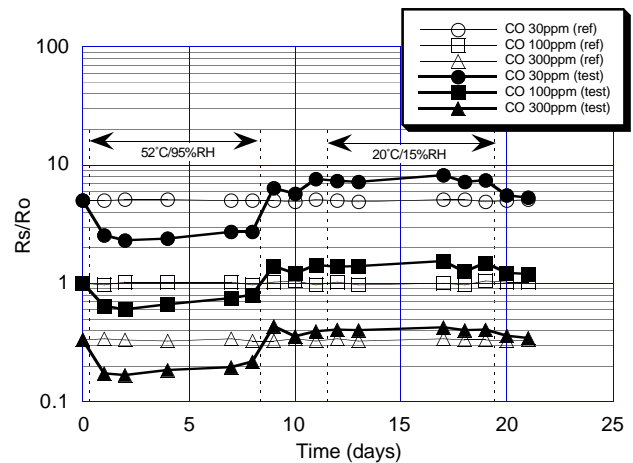

Figure 19 - Humidity test  
(Ro = Rs in 100ppm of CO at Day 0)

## 4-6 Stability test

### (1) False alarm test

To show the sensor's behavior under continuous low level exposure to CO, samples were tested against the procedure detailed in UL2034, Sec. 41.1(c)-Stability Test. Test samples were exposed to 30ppm continuously for a period of 30 days under standard circuit conditions. As this data demonstrates, false alarming does not occur as a result of continuous low level CO exposure.

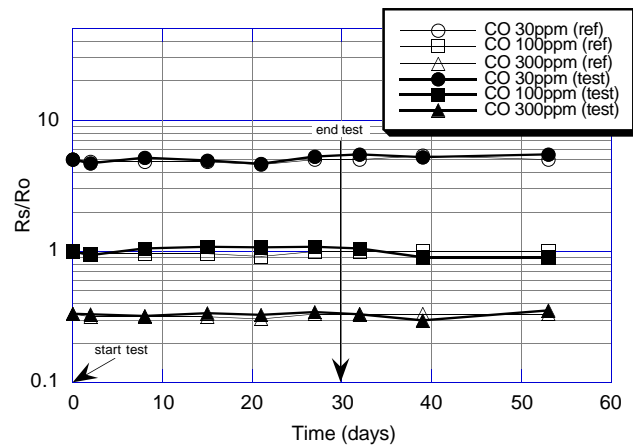

Figure 20 - False alarm test  
(Ro = Rs in 100ppm of CO prior to test)

### (2) Temperature cycle test

In accordance with UL2034, Sec. 41.1(e)-Stability Test, test samples were exposed to ten cycles (< 1 hr. and > 15 min.) of temperature from 0°C and 100%RH to 49°C and 40%RH. As the three test measurements taken after the conclusion of the test period demonstrate, sensors subjected to the test show negligible influence by temperature extremes.

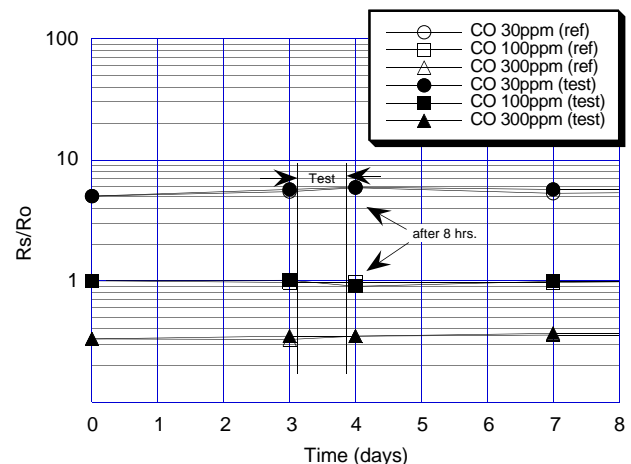

Figure 21 - Temperature cycle test  
(Ro = Rs in 100ppm of CO prior to test)

5. Circuit Examples

5-1 Basic circuit including trouble detection

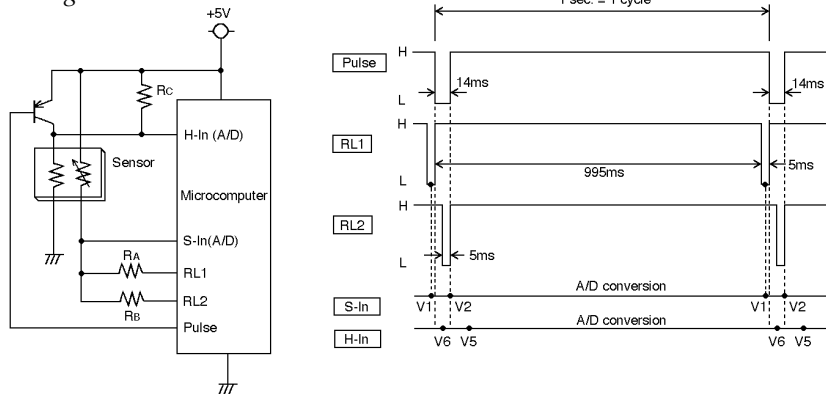

Figure 22 - Basic circuit (including trouble detection)

5-2 Calibration and temperature/humidity compensation

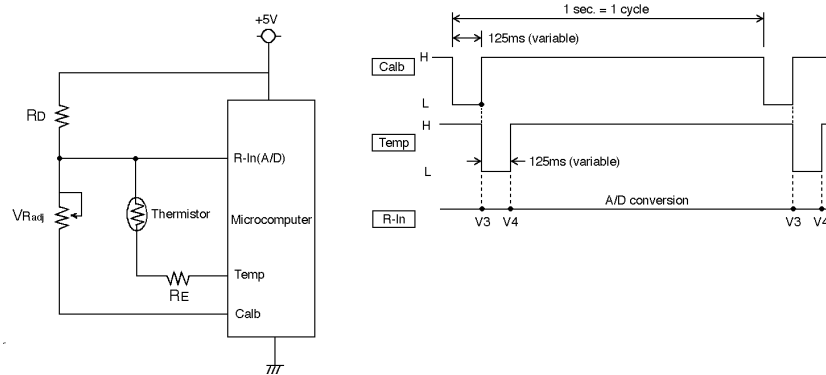

Figure 23 - Calibration & temperature compensation

S-In 8-bit A/D input port  
 H-In 8-bit A/D input port  
 R-In 8-bit A/D input port  
 (Each of these ports acquires data at preset timing.)

RL1,RL2 open drain output port  
 Pulse open drain output port  
 Temp open drain output port  
 Calb open drain output port

Circuit voltage (Vc) across the sensor is applied when RL1 or RL2 ports give the Low (L) output signal at preset timing.

V1 sampling voltage for gas detection  
 V2 sampling voltage for sensor element trouble detection  
 V3 sampling voltage for reference voltage  
 V4 sampling voltage for temperature compensation  
 V5,V6 sampling voltage for detecting heater circuit breakage

V1 and V2 are acquired during the last half of the 5msec Vc pulse (the first half of the Vc pulse is considered as the transient period). V5 is acquired during heater OFF, and V6 is acquired during heater ON pulse.

RA = 50% of Vc at the targeted gas concentration  
 RB = 200-300kΩ RC = 10kΩ  
 RD = 20kΩ RE = 10kΩ  
 VRadj = 100kΩ  
 Thermistor: R (25°C) = 10kΩ, B constant = 3400

Sensor resistance (Rs):

$$R_s = \frac{5 - V1}{V1}$$

Calibration resistance (RCalb):

$$R_{Calb} = \frac{5 - V3}{V3}$$

Coefficient for temp. compensation (KTemp):

$$K_{Temp} = \frac{5 - V4}{V4}$$

Operation state:

State	Conditions
Normal	$R_s \times K_{Temp} > R_{Calb}$ and $V2 \geq 0.5V$
Alarm	$R_s \times K_{Temp} \leq R_{Calb}$ and $V2 \geq 0.5V$
Sensor malfunction	$V2 < 0.5V$
Heater malfunction	$V5 \geq 0.1V$ or $V6 \leq 4.5V$

**Example of Application Circuit for TGS2442**

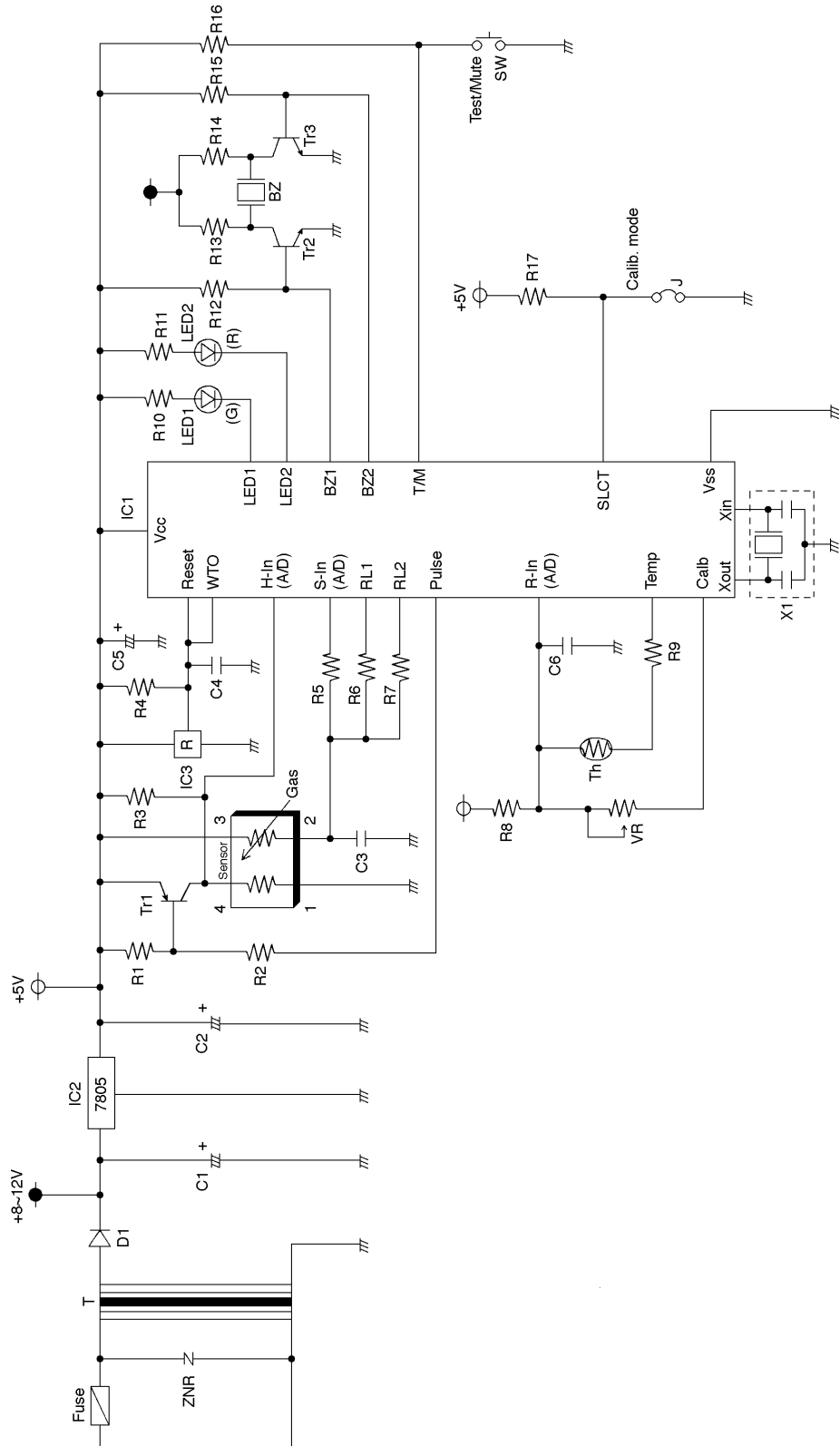

## TECHNICAL INFORMATION FOR TGS2442

### 6. Marking and Packaging

#### 6-1 Batch number

Rank and Lot. No. are indicated on the shrink wrap on the side of the sensor cap as shown in Figure 24.

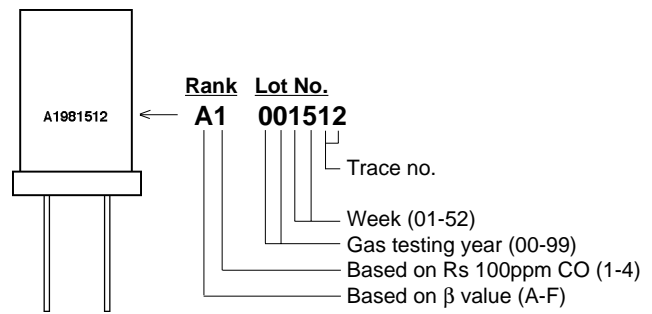

Figure 24 - Batch number coding

#### 6-2 Packaging method (Fig. 25)

Fifty (50) pieces of sensor are packed in a plastic container, and five (5) containers are sealed inside a moistureproof aluminum coated bag. Several bags are then packed in a carton box (see Fig. 26).

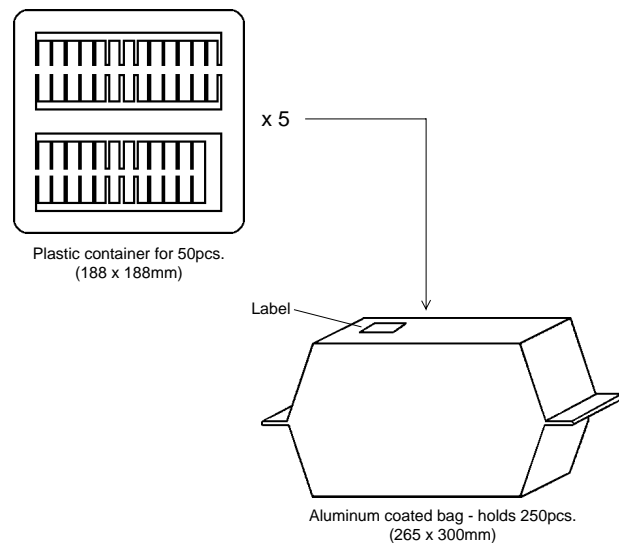

Figure 25 - Packing methodology

#### 6-3 Label

A label showing product name, Rank and Lot No., quantity, and inspection date is affixed to the aluminum coated bag.

#### 6-4 Handling instructions

It is recommended to begin sensor preheating within 24 hours after opening a sealed bag. Please keep unused sensors in a tightly sealed moistureproof bag.

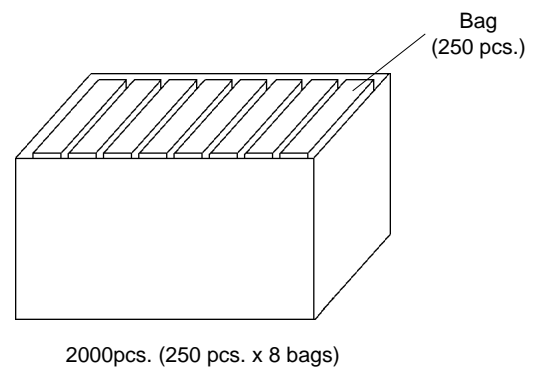

Figure 26 - Carton box



# FIGARO

## Signal Processing and Calibration Techniques for CO Detectors Using TGS2442

This brochure offers users important technical advice for handling and calibration of the TGS2442 CO sensor, including calibration techniques using a microprocessor. Detector circuit and calibration facility design should be carried out with these points in mind.



*Page*

<i>Basic Circuit Structure</i> .....	2
<i>Method of Signal Processing</i>	
Basic flow.....	2
Detection of sensor-related trouble conditions.....	2
Calculation of CO concentration	
Sensor resistance (Rs) calculation.....	4
Temperature compensation of $f(R_s)$ .....	4
Compensation for variation in Rs grades.....	5
Compensation for variation within $\beta$ grades.....	5
Converting $f(R_s^{\textcircled{2}})$ to CO concentration output.....	5
<i>Calibration Using Classified Sensors</i>	
Preheating.....	6
Pre-calibration	
Select a load resistor.....	6
Compensation according to $\beta$ grade.....	6
Main calibration.....	7
Appendix-Calibration at two or more concentrations.....	8
<i>Ability of Sensor to Meet Performance Standards</i>	
Requirements of performance standard.....	8
Estimation of calibration accuracy.....	9
Conclusion.....	9

**IMPORTANT NOTE:** OPERATING CONDITIONS IN WHICH FIGARO SENSORS ARE USED WILL VARY WITH EACH CUSTOMER'S SPECIFIC APPLICATIONS. FIGARO STRONGLY RECOMMENDS CONSULTING OUR TECHNICAL STAFF BEFORE DEPLOYING FIGARO SENSORS IN YOUR APPLICATION AND, IN PARTICULAR, WHEN CUSTOMER'S TARGET GASES ARE NOT LISTED HEREIN. FIGARO CANNOT ASSUME ANY RESPONSIBILITY FOR ANY USE OF ITS SENSORS IN A PRODUCT OR APPLICATION FOR WHICH SENSOR HAS NOT BEEN SPECIFICALLY TESTED BY FIGARO.

In order to meet the various regulations to which CO detectors are subject, circuit design and method of calibration should be based on the performance of the gas sensor. Recommended procedures for usage of the TGS2442 CO sensor are set forth in this document.

**1. Basic Circuit Structure**

Circuit structure needed to satisfy performance standards should provide for complex signal processing, necessitating usage of a microcomputer with features such as those shown in Table 1. This microcomputer will process multiple signals from the sensor, a thermistor (for temperature compensation), and a potentiometer (for calibration). The microcomputer will output a control signal for alarm operation. The following six types of output signals should be monitored (refer to the sample circuit diagrams and timing charts in Figs. 1 and 2 on the facing page):

- V1: Sampling voltage for gas detection
- V2: Sampling voltage for sensor element trouble detection
- V3: Sampling voltage for reference voltage
- V4: Sampling voltage for temperature compensation
- V5,V6: Sampling voltage for detecting heater trouble

CPU core	4 or 8 bit microcomputer (with 2~8MHz clock)
Memory size	2~4k byte ROM 128~256 nibble or byte RAM
Pin size	28~32 pins
Option	8-bit A/D converter (more than 3 channels) high current direct drive (more than 6 ports)
Mode selection port	select calibration or normal operation modes

Table 1 - Recommended microcomputer features

**2. Method of Signal Processing**

*2-1. Basic flow*

Figure 3 shows the basic flow of detector operation. To avoid potential nuisance alarming during the sensor's initial action period, a warm-up period of several minutes (alarm delay) should be utilized upon initial powering of the detector. After this period, the program in the microcomputer starts the main gas detection routine. During the gas detection routine, the above mentioned six output signals are acquired during each one second interval. V2, V5 and

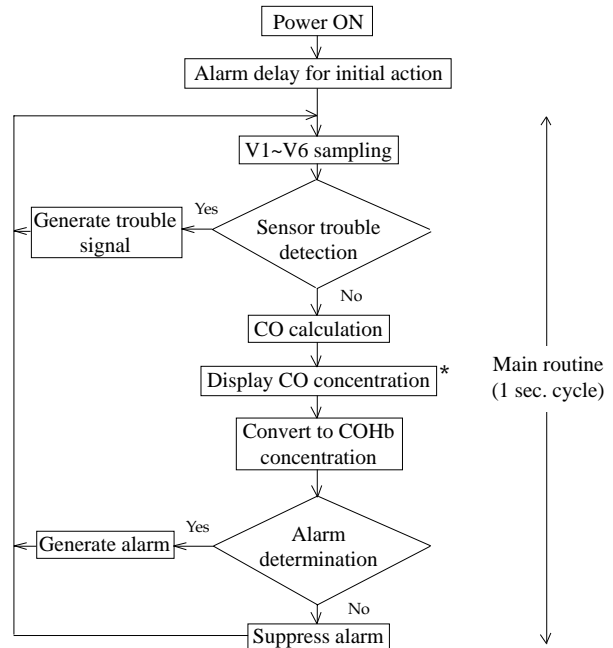

\* if applicable

Figure 3 - Basic flow of detector operation

V6 are used for detecting sensor-related trouble and heater driving circuit malfunction while V1, V3 and V4 are used to calculate CO gas concentration. This concentration is subsequently converted by time-weighting into a COHb concentration (the key measurement used in performance standards for determining the generation of alarm signals).

*2-2. Detection of sensor-related trouble conditions*

The sensor trouble mode should indicate that the sensor's heater has broken or that the sensor element itself has been damaged. The trouble signal for heater breakage can be detected by an abnormal rise in heater resistance or as a result of lead wire breakage, transistor problems, and/or short of the heater. The sensor element trouble signal is generated by damage to the sensing material or breakage of a lead wire. These phenomena produce an extreme change to the values of V5, V6 and V2; consequently monitoring V5, V6 and V2 enables detection of sensor-related trouble conditions. See Table 2 for recommended conditions for monitoring sensor-related trouble.

Heater trouble	V5 ≥ 0.1V V6 ≤ 4.5V
Sensor element damage	V2 ≤ 0.15V

Table 2 - Conditions under which an trouble signal should be generated

# CALIBRATION OF TGS2442

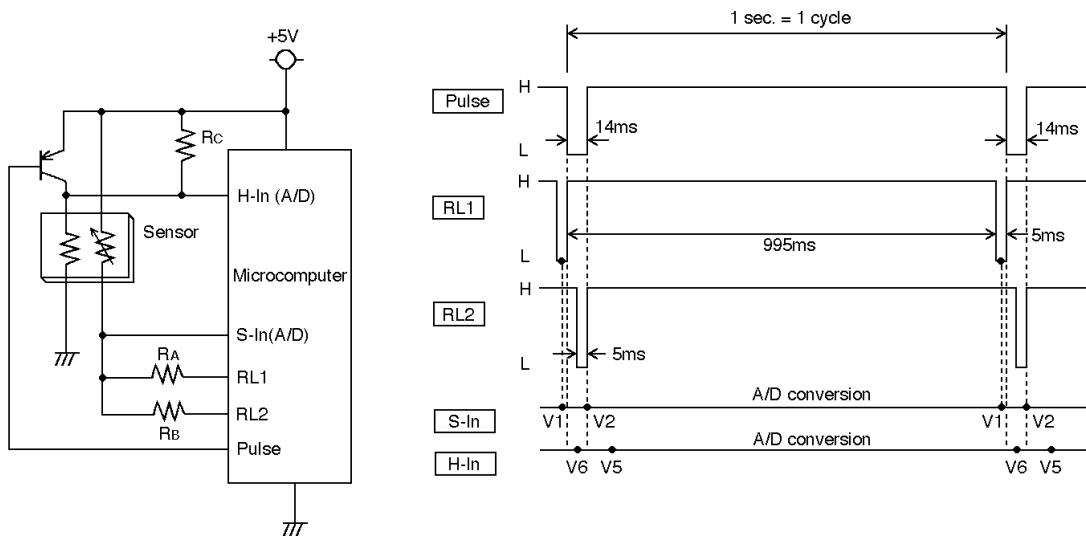

Figure 1 - Basic circuit (including trouble detection)

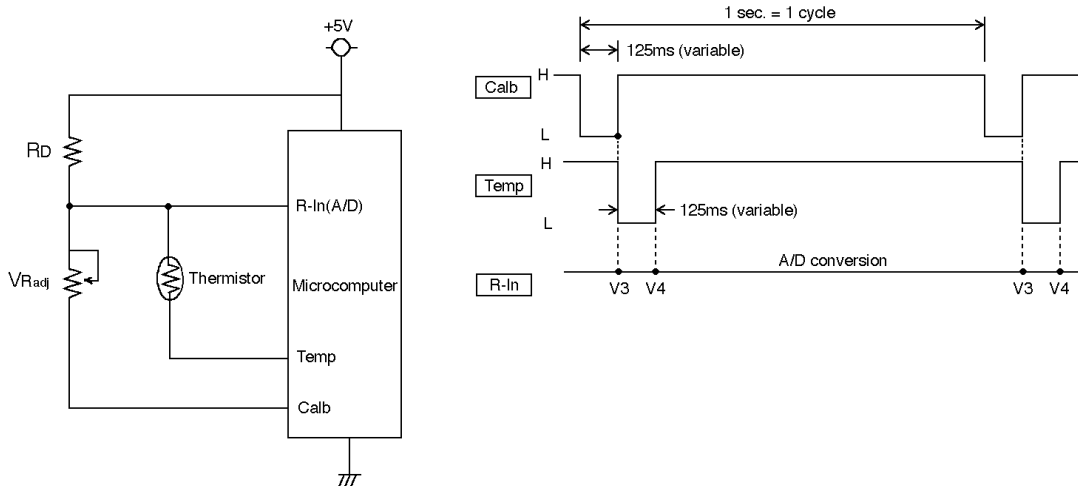

Figure 2 - Calibration & temperature compensation

### Legend of Circuit Diagrams

S-In 8-bit A/D input port  
 H-In 8-bit A/D input port  
 R-In 8-bit A/D input port

(Each of these ports acquires data at preset timing.)

RL1 open drain output port  
 RL2 open drain output port  
 Pulse open drain output port  
 Temp open drain output port  
 Calb open drain output port

Circuit voltage ( $V_c$ ) across the sensor is applied when RL1 or RL2 ports give the Low (L) output signal at preset timing.

V1 and V2 are acquired during the last half of the 5msec  $V_c$  pulse (the first half of the  $V_c$  pulse is considered as the transient period). V5 is acquired during heater OFF, and V6 is acquired during heater ON pulse.

$R_A$  = closest value to  $R_s$  at calibrated CO concentration  
 $R_B$  = 300k $\Omega$   
 $R_C$  = 10k $\Omega$   
 $R_D$  = 20k $\Omega$   
 $V_{Radj}$  = 100k $\Omega$   
 Thermistor: R (25°C) = 15k $\Omega$ , B constant = 4200

### 2-3. Calculation of CO concentration

Figure 4 illustrates the process for calculating CO concentration from V1, V3 and V4 signals.

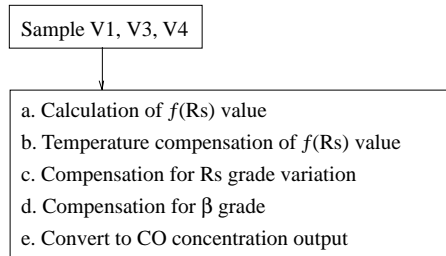

Figure 4 - Signal processing flow for calculation of CO concentration

#### a. Sensor resistance (Rs) calculation:

To represent sensor resistance (Rs) value in the microcomputer, the expression  $f(Rs)$  shall be used:

$$f(Rs) = (5 - V1) / V1$$

#### b. Temperature compensation of $f(Rs)$

In order to compensate for the temperature dependency of  $f(Rs)$  value, a temperature compensation coefficient ( $K_{Temp}$ ) must be determined.

$$K_{Temp} = Rs/Ro, \text{ where}$$

$R_s$  = actual sensor resistance in various conditions

$R_o$  = actual sensor resistance under standard conditions

Using the circuit condition and recommended thermistor in Figs. 1 & 2, measure actual  $R_s$  values at various ambient temperatures and sample thermistor output (V4). The correlation between V4 and  $K_{Temp}$  can be obtained by this procedure and should be written as a table of coefficients into ROM on the microcomputer. Then, by monitoring V4 output during normal operations, the proper  $K_{Temp}$  value can be selected from the table and used to temperature compensate  $f(Rs)$  values according to the following formula:

$$f(Rs^{\text{①}}) = f(Rs) / K_{Temp}$$

$f(Rs^{\text{①}})$  represents temperature compensated  $f(Rs)$ . Table 3 shows an example coefficient table for temperature compensation where measuring 100ppm of CO in 25°C/40%RH is used as a standard condition.

Figures 5a and 5b show typical values of  $f(Rs)$  before and after temperature compensation.

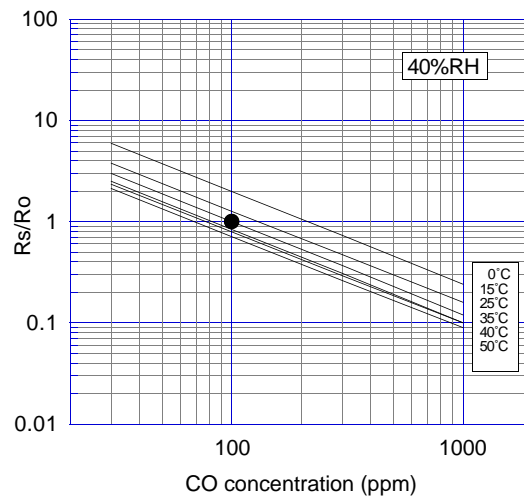

Figure 5a - Temperature dependency of  $R_s$  ( $R_o = R_s$  at 100ppm CO, 25°C/40%RH)

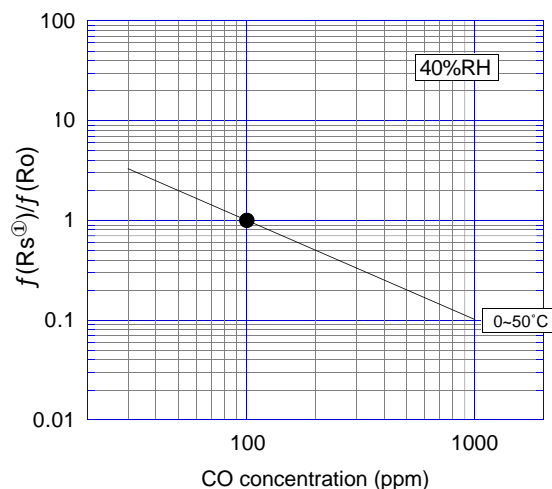

Figure 5b -  $f(Rs^{\text{①}})$  value compensated for temperature [ $f(Rs^{\text{①}})$ ] ( $R_o = R_s$  at 100ppm CO, 25°C/40%RH)

V4 Input Value	Temp (°C)	$K_{Temp}$ Coefficient
4.15	-10	2.72
3.92	-5	2.34
3.66	0	1.99
3.37	5	1.70
3.06	10	1.46
2.75	15	1.27
2.44	20	1.12
2.14	25	1.00
1.86	30	0.909
1.61	35	0.839
1.38	40	0.786
1.18	45	0.744
1.01	50	0.712
0.86	55	0.687
0.73	60	0.668

Table 3 - Table of temperature compensation coefficients

### c. Compensation for variation within $R_s$ grades

Variation in absolute  $R_s$  values among sensors within any given grade should be normalized by adjusting  $f(R_{ref})$  as part of the calibration process.

$$f(R_{ref}) = (5 - V3) / V3$$

$f(R_s^{(2)})$  is defined as a variation compensated  $f(R_s^{(1)})$  value:

$$f(R_s^{(2)}) = f(R_s^{(1)}) / f(R_{ref})$$

To calibrate the sensor correctly,  $f(R_s^{(2)})$  should be equal to 1.0 at the desired concentration. To do this, change  $V3$  values by adjusting  $V_{Adj}$ . Figures 6a and 6b show the variation within  $R_s$  grades and the result of compensating for such  $R_s$  variation.

### d. Compensation for variation within $\beta$ grades

Variation in sensitivity slopes ( $\alpha$ ) among sensors within any  $\beta$  grade should be compensated in the calibration process. This requires that a second  $f(R_s^{(2)})$  value (at 300ppm of CO, for example) be obtained:

- \* measure actual  $f(R_s)$  at second CO concentration
- \* calculate  $f(R_s^{(2)})$  for the second concentration
- \* using the  $f(R_s^{(2)})$  values for the two concentrations, calculate the slope ( $\alpha$ ):

$$\alpha = \frac{\log f(R_s^{(2)}) (300\text{ppm}) - \log f(R_s^{(2)}) (100\text{ppm})}{\log 300 - \log 100}$$

- \* store the  $\alpha$  value in the microcomputer

### e. Converting $f(R_s^{(2)})$ to CO concentration output

Using the sensitivity curve slope ( $\alpha$ ) determined above, actual CO concentration (C) can be calculated for usage in conversion to COHb:

$$C = 100 \times f(R_s^{(2)})^{1/\alpha}$$

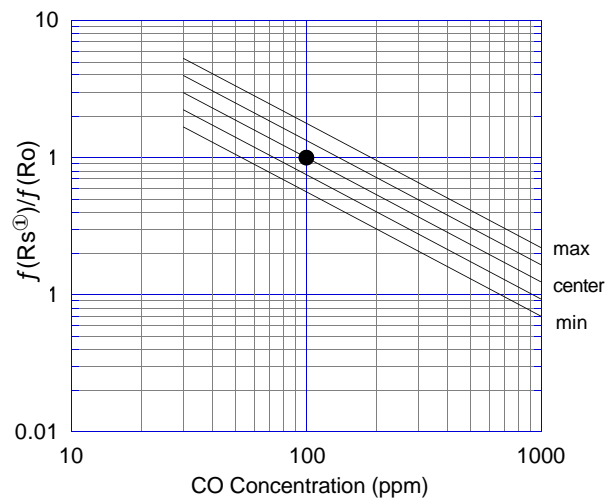

Figure 6a -  $R_s$  variation within  $R_s$  grades  
( $R_o = R_s$  at 100ppm CO, 25°C/40%RH)

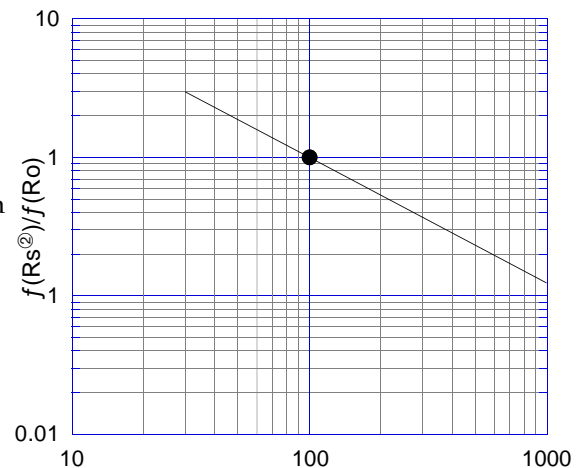

Figure 6b -  $R_s$  variation compensation  
( $R_o = R_s$  at 100ppm CO, 25°C/40%RH)

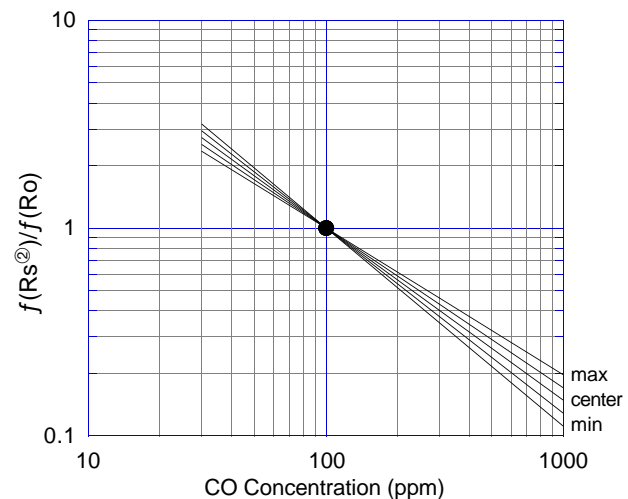

Figure 7 -  $\alpha$  variation within  $\beta$  grades  
( $R_o = R_s$  at 100ppm CO, 25°C/40%RH)

### 3. Calibration Using Classified Sensors

This section describes the procedure for calibrating at 100ppm of CO using sensors classified as shown in Tables 4 and 5. Figure 8 illustrates the flow of the calibration process, including the method of signal processing which takes place in the microcomputer.

#### 3-1. Preheating

To stabilize sensor characteristics prior to calibration, it is recommended that sensors be preheated under standard circuit conditions for 2 - 7 days. To shorten preheating time and simplify this process, Figaro is currently studying alternative methods and will issue new recommendations shortly.

#### 3-2. Pre-calibration (adjustment during assembly)

##### a. Select a load resistor (RL)

Select the load resistor (RL, same as RA in Figure 1) based on the Rs grade shown in Table 4. For optimal resolution, the RL used should have a value as close as possible to the Rs grade's center value. The sensor output signal (V1) at the calibration concentration should be near 2.5V which is 1/2 the value of Vc. According to the maximum and minimum values of Rs values for each Rs grade as shown in Table 4, V1 would fall in the following range:

$$1.70 \text{ v} \leq V1 \text{ (at 100ppm)} \leq 3.30 \text{ v}$$

##### b. Compensation according to $\beta$ grade

Each Rs grade is divided into six  $\beta$  grades as shown in Table 5. Using data from this table,  $\alpha$  values for these grades can be determined as follows and should be stored in the microcomputer (see Table 6):

$$\alpha = \log \beta \text{ (center)} / \log (300/100)$$

Using the  $\alpha$  value calculated above, compensation for  $\beta$  grade can be done by utilizing a circuit such as that shown in Figure 9 and connecting the three jumper lines as indicated in Table 6.

Grade	Rs in CO 100ppm (k $\Omega$ )			Recommended RL (k $\Omega$ )
	Min.	Center	Max.	
1	6.81	12.1	21.5	12
2	10.0	17.8	31.6	18
3	14.7	26.1	46.4	27
4	21.5	38.3	68.1	39

Table 4 - Rs grades of TGS2442

Grade	$\beta$ (Rs in 300ppm/Rs in 100ppm)		
	Min.	Center	Max.
A	0.230	0.285	0.340
B	0.260	0.315	0.370
C	0.290	0.345	0.400
D	0.320	0.375	0.430
E	0.350	0.405	0.460
F	0.380	0.435	0.490

Table 5 -  $\beta$  grades of TGS2442

$\beta$ Grade	$\alpha$ Value	Jumper Connection
A	-1.14	001
B	-1.05	010
C	-0.969	011
D	-0.862	100
E	-0.823	101
F	-0.758	110

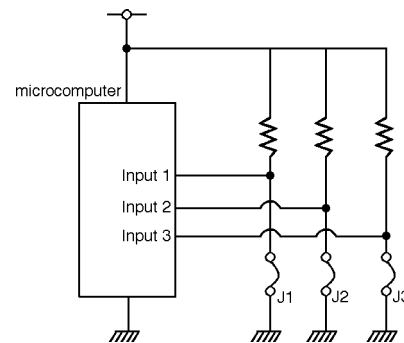
Table 6 - Recommended jumper connections for  $\beta$  grade compensation circuitFigure 9 - Recommended circuit for  $\beta$  grade compensation

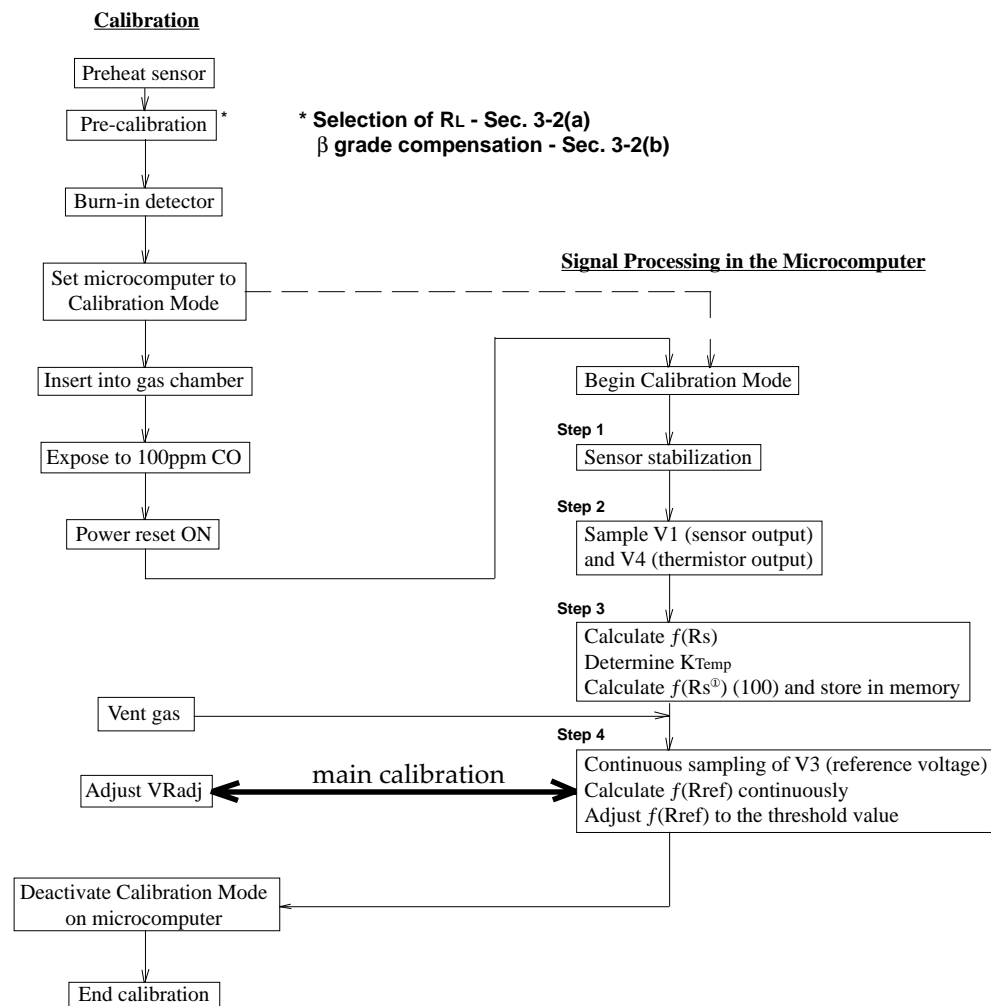

Figure 8 - Calibration and signal processing in the microcomputer

### 3-3. Main calibration (using "Calibration Mode" in the microcomputer)

Using the mode selection port on the microcomputer, select "Calibration Mode". Switch the detector ON (Reset), activating calibration mode. Signal processing in the microcomputer during the calibration mode proceeds as shown in Figure 8. Place the detector in a vessel which is then filled with 100ppm of CO.

#### Step 1:

Stabilize sensor output V1 in 100ppm of CO for the predetermined period stored in the microcomputer.

#### Step 2:

Obtain V1 and V4 at the conclusion of stabilization.

#### Step 3:

Calculate  $f(R_s)$ ,  $K_{Temp}$ ,  $f(R_s^{\text{D}})$  according to the procedure in Section 2-3(a,b). The value  $f(R_s^{\text{D}})$  is stored temporarily in the microcomputer's RAM.

#### Step 4:

After ventilating the calibration gas, V3 is continuously monitored and converted to  $f(R_{ref})$  [see equation in 2-3(c)]. Using a potentiometer (VRadj), adjust  $f(R_{ref})$  to equal  $f(R_s^{\text{D}})$  in 100ppm of CO which was memorized in Step 3. This procedure can be simplified by directing the microcomputer to activate an LED when  $f(R_{ref})$  is set to the correct level.

For example: If  $f(R_{ref}) = [f(R_s^{\text{D}})(100\text{ppm})] \pm 3\%$ , then "LED TURN ON" else "LED TURN OFF"



### Appendix-Calibration at two or more concentrations

Detectors which display CO concentration demand more accurate calculation of CO concentrations. To obtain sufficient accuracy, calibration should be conducted at two or more CO concentrations according to the signal processing procedures in Section 2. For illustration, an example of 300ppm and 100ppm of CO as calibration points is used in this section.

The procedure of compensation according to  $\beta$  grade in Section 3-2(b) may be omitted. Instead,  $f(R_s)$  of a second CO concentration (300ppm in this case) is obtained by following Steps 1~ 4 in Section 3-3. By this procedure, the sensor's  $\beta$  value can be obtained for each detector from the following equation:

$$\beta = f(R_s)(300\text{ppm}) / f(R_s)(100\text{ppm})$$

In turn, this  $\beta$  value can be converted into an  $\alpha$  value by using the equation shown in Section 3-2(b). This  $\alpha$  value ( $\alpha_{\text{mem}}$ ) is temporarily stored in the RAM of the microcomputer (see Sec. 2-3(d)).

To compensate for the slope of the sensitivity curve, a slope compensation circuit shown in Figure 10a can be used. Since the range of values for V7 is from 0 ~ 5V and the range of  $\alpha$  values is from -1.4 ~ -0.6, a linear relationship between the V7 and  $\alpha$  can be established (see Figure 10b). Then, in order to compensate for  $\alpha$  value, the V7 port is used--adjust the potentiometer (VRadj2) so that the  $\alpha_{\text{calb}}$  value is set as close to  $\alpha_{\text{mem}}$  as possible. This procedure can be simplified by directing the microcomputer to activate an LED when  $\alpha$  is set to the correct level:

For example: If  $\alpha_{\text{calb}} = \alpha_{\text{mem}} \pm 3\%$ ,  
then "LED TURN ON" else "LED TURN OFF"

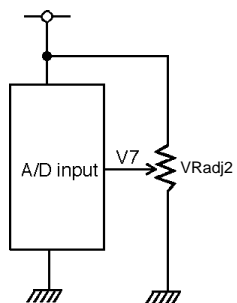

Figure 10a - Slope compensation circuit

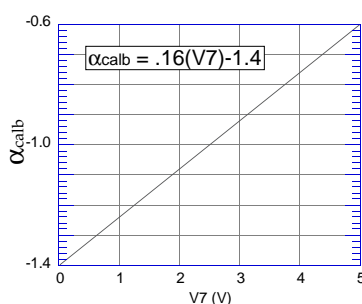

Figure 10b - Relationship of slope (a) to V7

Following these procedures, each sensor can be fully compensated for temperature and sensitivity slope.

### 4. Ability of Sensor to Meet Performance Standards

This section will show how TGS2442, if used in the manner described in this document, can satisfy CO detector performance standards such as UL2034 and the CSA 6-96 standard. The following assumptions are made for this purpose:

- \* no error exists in calibration gas concentration
- \* no adjustment error in VRadj exists
- \* the gas sensitivity curve is linear on a logarithmic scale between 60-600ppm of CO
- \* no error exists in temperature compensation

Under these conditions, accuracy of calibration will depend upon the accuracy of  $f(R_s)$  and  $\beta$ . When calibration is done using two or more CO concentrations (Section 3-Appendix), calibration without error can be done at the targeted gas concentration. However, if calibration is done only at one gas concentration and is based on one of the combinations of  $R_s$  and  $\beta$  grades supplied for the sensor, since  $\beta$  falls within a range for each grade, verification that such variation in  $\beta$  falls within acceptable limits is required.

#### 4-1 Requirements of performance standard

The most stringent performance standard (CSA 6-96) requires that an alarm be generated at not less than 5% COHb but less than 10% COHb. The specified CO concentration and accumulation times

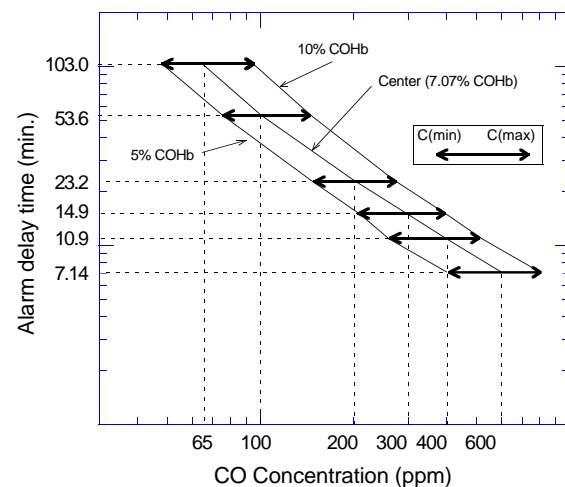

Figure 11 - Alarm times permitted by performance standard

for each concentration are spelled out by the standard. While the standard lists specific delay times allowed for each CO concentration, to facilitate this discussion the permissible range of CO concentrations at each specific delay time will be used.

The maximum and minimum values of alarming time permitted by the standard for each CO concentration are plotted on the chart shown in Figure 11. The log center between these two curves (7.07% COHb) is also plotted. From these curves, the values of concentration width allowed at each delay time can be determined—see Table 7 for a listing of these values.

#### 4-2 Estimation of calibration accuracy

The variation in each  $\beta$  grade can be illustrated as in Figure 12. The center line is based on the  $\beta$  center value which is given to each sensor grade. At the calibration point of 100ppm, the  $f(Rs^2)$  value of each sensor would be the same ( $f(Rs^2) = 1.0$ ). But at 60 and 600ppm, the  $f(Rs^2)$  could vary as shown in the chart. At each concentration of CO, the center  $f(Rs^2)$  can be identified and the +/- range of  $f(Rs^2)$  values can also be determined. If the maximum and minimum  $f(Rs^2)$  values fall within the allowable ranges of the standard (Table 7), then sensors calibrated at one CO concentration could satisfy the requirements of the performance standards. Table 8 shows maximum and minimum CO concentrations for each sensor grade compared to the range of CO concentrations permitted by performance standards.

#### 4-3 Conclusion

As Table 8 illustrates, properly calibrated TGS2442 sensors can satisfy the requirements of current

performance standards even if calibrated with only one CO concentration. This verification is based on the aforementioned assumptions. Any factors which may influence these assumptions should be taken into consideration when planning actual detector design and when designing the calibration process.

Alarm time ( $t_{conc.}$ ) in minutes	CO Concentration (ppm)		
	C (min)	C (center)	C (max)
$t_{65} = 103$	48	65	95
$t_{100} = 53.6$	75	100	145
$t_{200} = 23.2$	145	200	270
$t_{300} = 14.9$	210	300	400
$t_{400} = 10.9$	260	400	520
$t_{600} = 7.14$	400	600	800

Table 7 - CO concentration ranges vs. alarm times as specified by performance standard

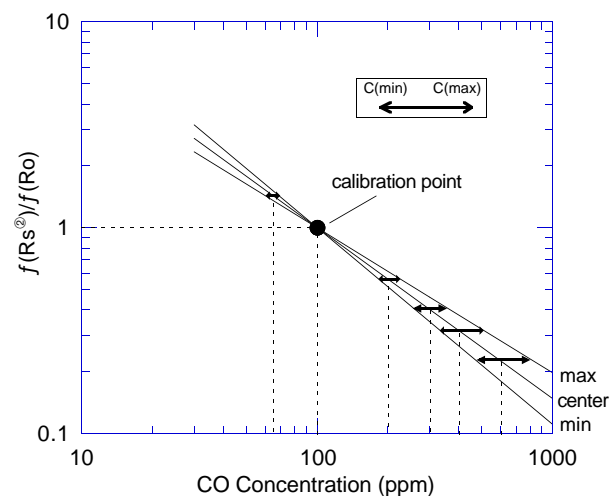

Figure 12 - Variation of alarm concentrations in  $\beta$  grades ( $R_o = R_s$  at 100ppm CO, 25°C/40%RH)

Test Point $\beta$ Grade	CO Concentration Range (ppm)				
	65ppm	100ppm	200ppm	300ppm	400ppm
A	60.6-69.0	100	181-224	257-358	329-500
B	60.6-69.0	100	182-224	257-359	330-501
C	60.6-69.0	100	182-224	258-359	330-502
D	60.5-69.0	100	182-225	257-360	330-504
E	60.4-69.1	100	181-225	257-362	329-507
F	60.3-69.1	100	181-225	256-365	329-511
Standard Requirement	48 ~ 95	75 ~ 145	145 ~ 270	210 ~ 400	260 ~ 520

Table 8 - TGS2442 alarm concentrations vs. performance standard requirements

Appendix

**TGS2442 Temperature Compensation Factors**  
supplementary data

V4 Input Value	Temp (°C)	KTemp Coefficient
4.15	-10	2.72
4.11	-9	2.64
4.06	-8	2.56
4.02	-7	2.49
3.97	-6	2.41
3.92	-5	2.34
3.87	-4	2.26
3.82	-3	2.19
3.77	-2	2.12
3.71	-1	2.06
3.66	0	1.99
3.60	1	1.93
3.54	2	1.87
3.49	3	1.81
3.43	4	1.76
3.37	5	1.70
3.31	6	1.65
3.25	7	1.60
3.19	8	1.55
3.13	9	1.51
3.06	10	1.46
3.00	11	1.42
2.94	12	1.38
2.88	13	1.34
2.81	14	1.30
2.75	15	1.27
2.69	16	1.24
2.63	17	1.20
2.56	18	1.17
2.50	19	1.14
2.44	20	1.12
2.38	21	1.09
2.32	22	1.07
2.26	23	1.04
2.20	24	1.02
2.14	25	1.00

V4 Input Value	Temp (°C)	KTemp Coefficient
2.09	26	0.980
2.03	27	0.961
1.97	28	0.943
1.92	29	0.926
1.86	30	0.909
1.81	31	0.894
1.76	32	0.879
1.71	33	0.865
1.66	34	0.852
1.61	35	0.839
1.56	36	0.827
1.52	37	0.816
1.47	38	0.805
1.43	39	0.795
1.38	40	0.786
1.34	41	0.776
1.30	42	0.768
1.26	43	0.759
1.22	44	0.752
1.18	45	0.744
1.14	46	0.737
1.11	47	0.730
1.07	48	0.724
1.04	49	0.718
1.01	50	0.712
0.975	51	0.706
0.944	52	0.701
0.914	53	0.696
0.885	54	0.692
0.857	55	0.687
0.830	56	0.683
0.803	57	0.679
0.778	58	0.675
0.753	59	0.671
0.729	60	0.668

