

## TGS 2610 - for the detection of Combustible Gases

### Features:

- \* General purpose sensor with sensitivity to wide variety of combustible gas
- \* Low power consumption
- \* High sensitivity to methane, propane, and butane
- \* Long life and low cost
- \* Uses simple electrical circuit

The sensing element is comprised of a metal oxide semiconductor layer formed on an alumina substrate of a sensing chip together with an integrated heater. In the presence of a detectable gas, the sensor's conductivity increases depending on the gas concentration in the air. A simple electrical circuit can convert the change in conductivity to an output signal which corresponds to the gas concentration.

The TGS 2610 has high sensitivity to propane, methane, and butane, making it ideal for natural gas and LPG monitoring. The sensor can detect a wide range of gases, making it an excellent, low cost sensor for a variety of applications.

Due to miniaturization of the sensing chip, TGS 2610 requires a heater current of only 56mA and the device is housed in a standard TO-5 package.

The figure below represents typical sensitivity characteristics, all data having been gathered at standard test conditions (see reverse side of this sheet). The Y-axis is indicated as *sensor resistance ratio* ( $R_s/R_o$ ) which is defined as follows:

$R_s$  = Sensor resistance in displayed gases at various concentrations

$R_o$  = Sensor resistance in 1500ppm of iso-butane

### Applications:

- \* Domestic gas leak detectors and alarms
- \* Portable gas detectors
- \* Combustible gas and vapor detection

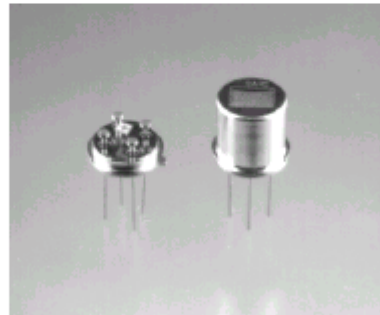

The figure below represents typical temperature and humidity dependency characteristics. Again, the Y-axis is indicated as *sensor resistance ratio* ( $R_s/R_o$ ), defined as follows:

$R_s$  = Sensor resistance at 1500ppm of iso-butane at various temperatures/humidities

$R_o$  = Sensor resistance at 1500ppm of iso-butane at 20°C and 65% R.H.

### Sensitivity Characteristics:

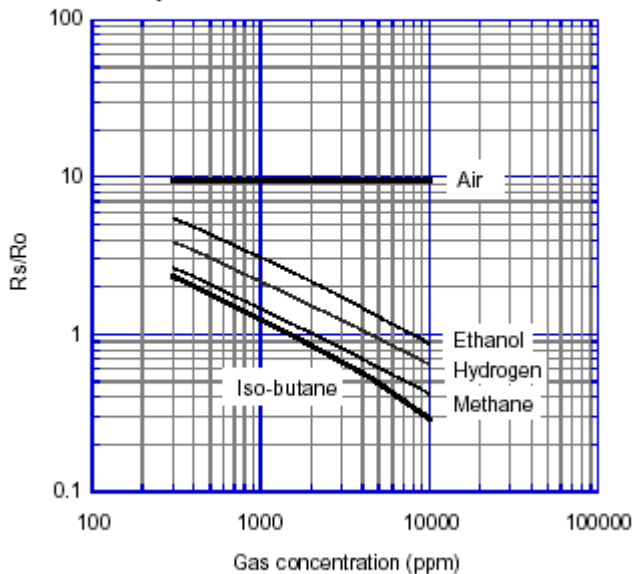

### Temperature/Humidity Dependency:

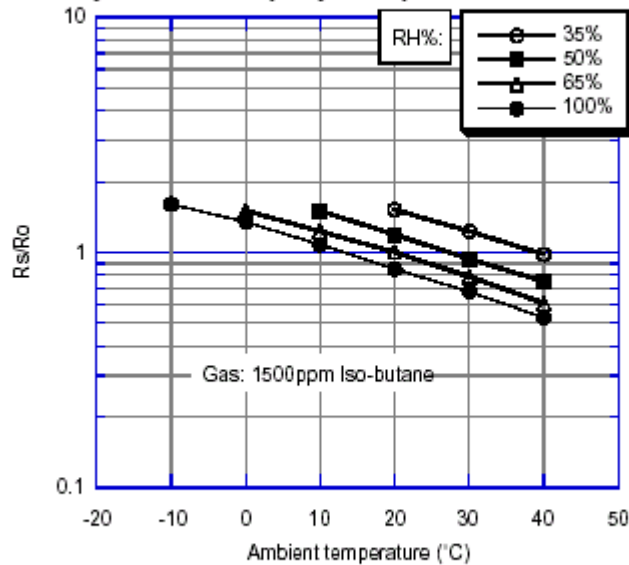

**IMPORTANT NOTE:** OPERATING CONDITIONS IN WHICH FIGARO SENSORS ARE USED WILL VARY WITH EACH CUSTOMER'S SPECIFIC APPLICATIONS. FIGARO STRONGLY RECOMMENDS CONSULTING OUR TECHNICAL STAFF BEFORE DEPLOYING FIGARO SENSORS IN YOUR APPLICATION AND, IN PARTICULAR, WHEN CUSTOMER'S TARGET GASES ARE NOT LISTED HEREIN. FIGARO CANNOT ASSUME ANY RESPONSIBILITY FOR ANY USE OF ITS SENSORS IN A PRODUCT OR APPLICATION FOR WHICH SENSOR HAS NOT BEEN SPECIFICALLY TESTED BY FIGARO.

## Basic Measuring Circuit:

The sensor requires two voltage inputs: heater voltage ( $V_H$ ) and circuit voltage ( $V_C$ ). The heater voltage ( $V_H$ ) is applied to the integrated heater in order to maintain the sensing element at a specific temperature which is optimal for sensing. Circuit voltage ( $V_C$ ) is applied to allow measurement of voltage ( $V_{RL}$ ) across a load resistor ( $R_L$ ) which is connected in series with the sensor.

A common power supply circuit can be used for both  $V_C$  and  $V_H$  to fulfill the sensor's electrical requirements. The value of the load resistor ( $R_L$ ) should be chosen to optimize the alarm threshold value, keeping power dissipation ( $P_s$ ) of the semiconductor below a limit of 15mW. Power dissipation ( $P_s$ ) will be highest when the value of  $R_s$  is equal to  $R_L$  on exposure to gas.

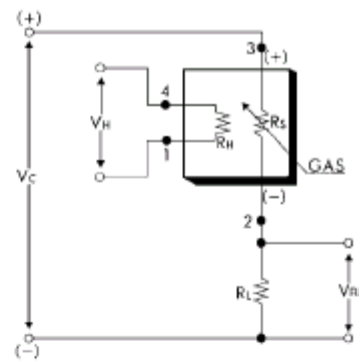

## Specifications:

Model number		TGS 2610	
Sensing element type		D1	
Standard package		TO-5 metal can	
Target gases		Combustible gases	
Typical detection range		500 ~ 10,000 ppm	
Standard circuit conditions	Heater Voltage	$V_H$	5.0±0.2V DC/AC
	Circuit voltage	$V_C$	5.0±0.2V DC $P_s \leq 15mW$
	Load resistance	$R_L$	Variable $P_s \leq 15mW$
Electrical characteristics under standard test conditions	Heater resistance	$R_H$	approx. 59Ω at room temp.
	Heater current	$I_H$	56 ± 5mA
	Heater power consumption	$P_H$	280mW $V_H = 5.0V DC$
	Sensor resistance	$R_s$	1 ~ 5 kΩ in 1500ppm iso-butane
	Sensitivity (change ratio of $R_s$ )		0.53 ± 0.05 $\frac{R_s(4500ppm)}{R_s(1500ppm)}$
Standard test conditions	Test gas conditions	Iso-butane vapor in air at 20±2°C, 65±5%RH	
	Circuit conditions	$V_C = 5.0\pm0.01V DC$ $V_H = 5.0\pm0.05V DC$	
	Conditioning period before test	7 days	

The value of power dissipation ( $P_s$ ) can be calculated by utilizing the following formula:

$$P_s = \frac{(V_C - V_{RL})^2}{R_s}$$

Sensor resistance ( $R_s$ ) is calculated with a measured value of  $V_{RL}$  by using the following formula:

$$R_s = \frac{V_C - V_{RL}}{V_{RL}} \times R_L$$

## Structure and Dimensions:

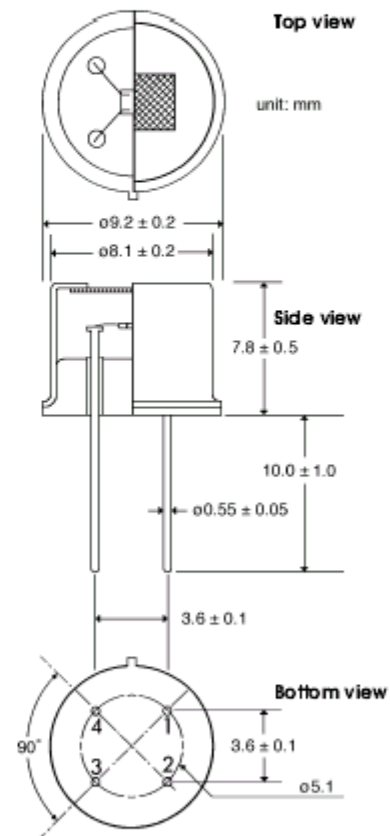

### Pin connection:

- 1 : Heater
- 2 : Sensor electrode (-)
- 3 : Sensor electrode (+)
- 4 : Heater