

SPDT FET Switch

TGS8706-SCC

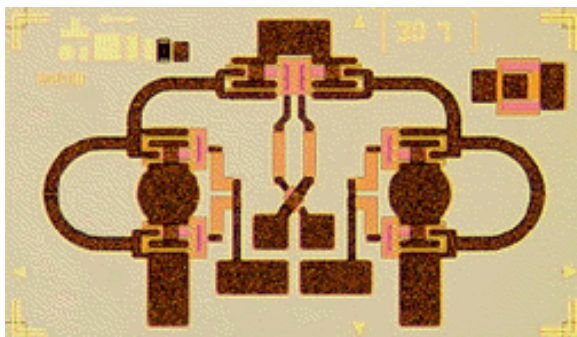

Key Features and Performance

- DC to 8 GHz Frequency Range
- 0.7 dB Insertion Loss and 40 dB Isolation at Midband
- 1.1:1 Input/Output SWR at Midband
- Greater than 0.5 W Input Power at 1 dB Gain Compression
- 1.625 x 0.965 x 0.152 mm (0.064 x 0.038 x 0.006 in.)

Description

The TriQuint TGS8706-SCC is one of a family of low frequency single-pole double-throw switches. This broadband reflective switch has low power consumption and can be easily configured for single-pole multi-throw blocks.

The TGS8706-SCC is suitable for all applications that require small size, low insertion loss, and minimal current consumption, such as EW, phased-array radars, and telecommunications systems.

Bond pad and backside metallization are gold plated for compatibility with eutectic alloy attachment methods as well as the thermocompression and thermosonic wire bonding processes. Ground is provided to the circuit through vias to the backside metallization.

**TYPICAL
INSERTION LOSS**

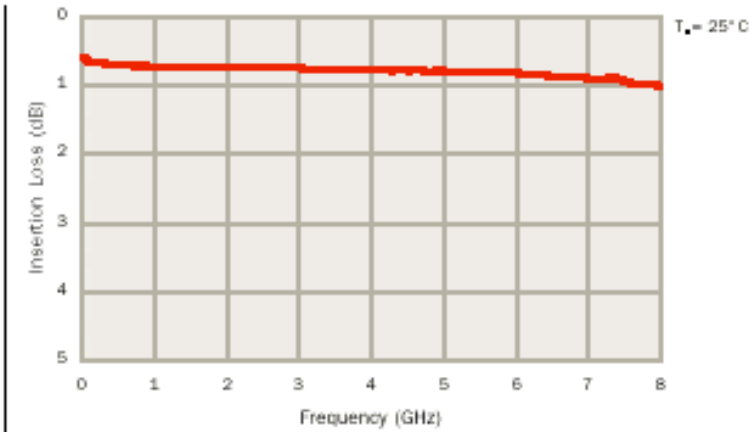

**TYPICAL
ISOLATION**

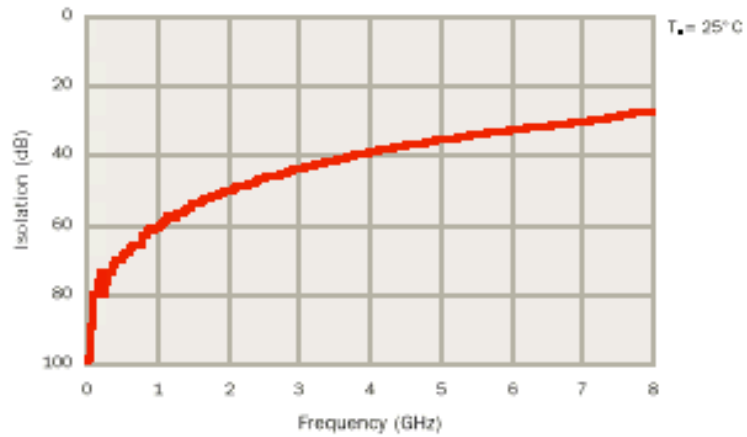

**TYPICAL
INPUT POWER
P_{1dB}**

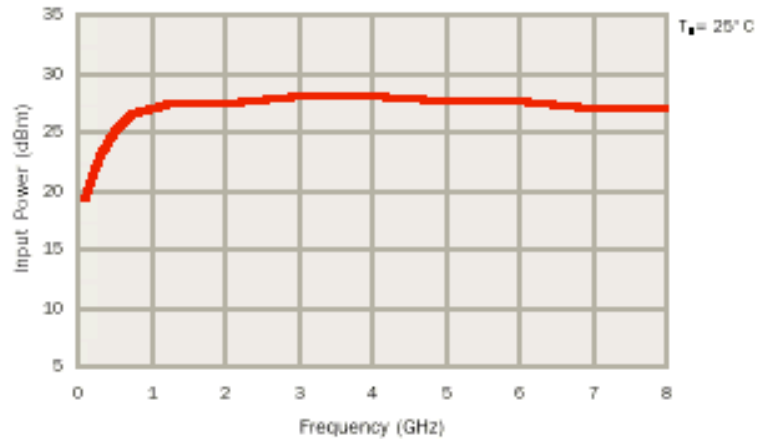

**TYPICAL
RETURN LOSS**

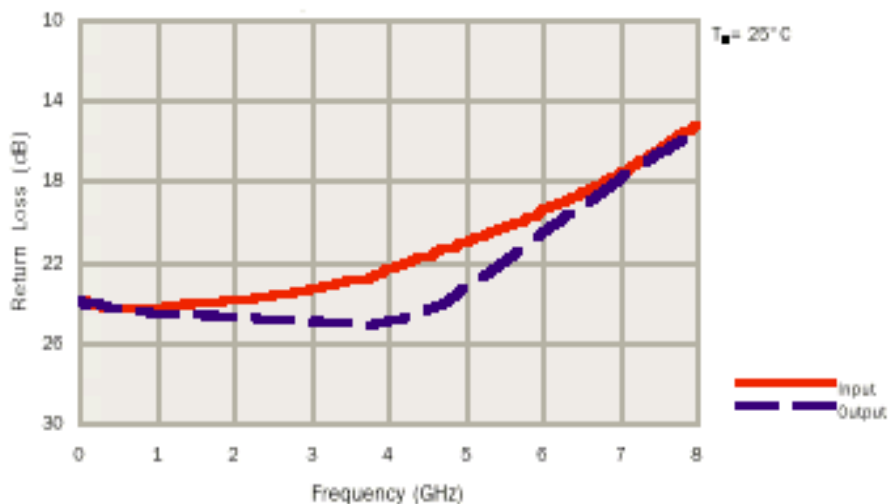

**ABSOLUTE
MAXIMUM RATINGS**

Input continuous wave power, P_{IN}^*	2 W
Control voltage range, V_1, V_2, V_3, V_4	-10 V to 0 V
Operating channel temperature, T_{CH}^{**}	150°C
Mounting temperature (30 sec), T_M	320°C
Storage temperature range, T_{STG}	-65 to 150°C

Ratings over channel temperature range, T_{CH} (unless otherwise noted)

Stresses beyond those listed under "Absolute Maximum Ratings" may cause permanent damage to the device. These are stress ratings only and functional operation of the device at these or any other conditions beyond those indicated under "RF Characteristics" is not implied. Exposure to absolute maximum rated conditions for extended periods may affect device reliability.

* DC blocks are not provided at RF ports.

** Operating channel temperature will directly affect the device MTTF. For maximum life, it is recommended that channel temperature be maintained at the lowest possible level.

TYPICAL S-PARAMETERS

Low Loss Path

Frequency (GHz)	S ₁₁		S ₂₁		S ₁₂		S ₂₂		Insertion Loss (dB)
	MAG	ANG(°)	MAG	ANG(°)	MAG	ANG(°)	MAG	ANG(°)	
0.05	0.06	1	0.93	-1	0.93	-1	0.06	3	0.6
0.5	0.06	-4	0.92	-5	0.92	-5	0.06	-8	0.7
1.0	0.06	-6	0.92	-9	0.92	-9	0.06	-15	0.7
1.5	0.06	-9	0.92	-14	0.92	-14	0.06	-23	0.7
2.0	0.06	-13	0.92	-18	0.92	-18	0.06	-32	0.8
2.5	0.07	-18	0.92	-23	0.92	-23	0.06	-43	0.8
3.0	0.07	-25	0.92	-27	0.92	-27	0.06	-54	0.8
3.5	0.07	-34	0.92	-32	0.91	-32	0.06	-67	0.8
4.0	0.08	-43	0.91	-37	0.91	-36	0.06	-82	0.8
4.5	0.08	-53	0.91	-41	0.91	-41	0.06	-97	0.8
5.0	0.09	-63	0.91	-46	0.91	-46	0.07	-112	0.8
5.5	0.10	-74	0.91	-51	0.91	-50	0.08	-125	0.8
6.0	0.11	-84	0.91	-55	0.91	-55	0.09	-137	0.8
6.5	0.12	-94	0.90	-60	0.90	-60	0.11	-146	0.9
7.0	0.13	-104	0.90	-65	0.90	-65	0.13	-155	0.9
7.5	0.15	-113	0.90	-70	0.90	-70	0.15	-164	0.9
8.0	0.17	-122	0.89	-75	0.89	-75	0.16	-174	1.0
8.5	0.19	-130	0.88	-79	0.88	-79	0.17	-179	1.1
9.0	0.21	-136	0.88	-84	0.88	-84	0.20	177	1.1
9.5	0.23	-142	0.88	-89	0.87	-90	0.23	170	1.1
10.0	0.24	-150	0.87	-95	0.87	-95	0.26	163	1.2

T_A = 25°C

Reference planes for S-parameter data include bond wires as specified in the "Recommended Assembly Diagram". The S-parameters are also available on floppy disk and the world wide web.

TYPICAL S-PARAMETERS
Isolated Path

Frequency (GHz)	S ₁₁		S ₂₁		S ₁₂		S ₂₂		Isolation (dB)
	MAG	ANG(°)	MAG	ANG(°)	MAG	ANG(°)	MAG	ANG(°)	
0.05	0.07	33	0.0000	55	0.0001	- 61	0.85	179	99.0
0.5	0.08	7	0.0003	163	0.0004	175	0.84	176	70.5
1.0	0.08	7	0.0009	163	0.0010	169	0.84	173	60.9
1.5	0.09	8	0.0020	162	0.0019	162	0.83	169	54.0
2.0	0.09	8	0.0030	159	0.0029	161	0.83	166	50.5
2.5	0.10	6	0.0046	160	0.0043	161	0.82	163	46.7
3.0	0.11	0	0.0063	158	0.0062	158	0.82	160	44.0
3.5	0.11	- 7	0.0082	156	0.0084	157	0.82	157	41.7
4.0	0.12	- 16	0.0108	153	0.0107	155	0.82	154	39.3
4.5	0.13	- 26	0.0134	150	0.0137	150	0.82	151	37.5
5.0	0.14	- 35	0.0163	148	0.0163	147	0.81	148	35.8
5.5	0.15	- 44	0.0195	145	0.0193	145	0.80	146	34.2
6.0	0.16	- 53	0.0226	142	0.0224	142	0.80	144	32.9
6.5	0.17	- 64	0.0261	139	0.0261	140	0.80	143	31.7
7.0	0.19	- 76	0.0302	137	0.0300	138	0.80	142	30.4
7.5	0.21	- 87	0.0359	136	0.0359	136	0.81	140	28.9
8.0	0.24	- 98	0.0429	129	0.0433	128	0.81	137	27.4
8.5	0.28	- 112	0.0513	114	0.0518	113	0.80	135	25.8
9.0	0.30	- 123	0.0474	105	0.0475	105	0.80	133	26.5
9.5	0.33	- 132	0.0503	99	0.0496	99	0.80	130	26.0
10.0	0.34	- 143	0.0513	87	0.0504	88	0.79	128	25.8

T_A = 25°C

Reference planes for S-parameter data include bond wires as specified in the "Recommended Assembly Diagram". The S-parameters are also available on floppy disk and the world wide web.

EQUIVALENT SCHEMATIC

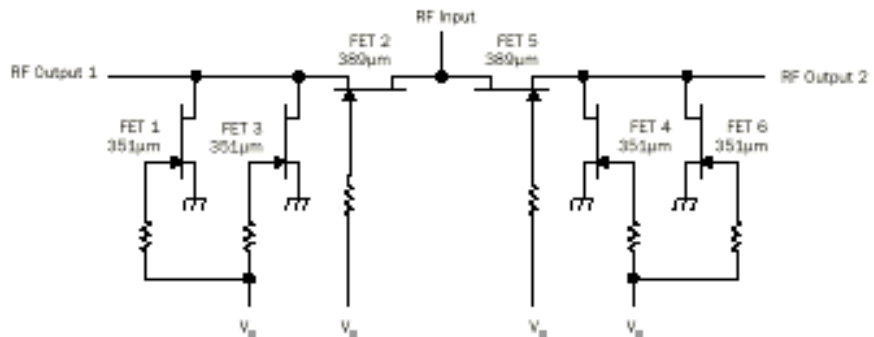

DC blocks are not provided at RF ports.

**RECOMMENDED
ASSEMBLY DIAGRAM**

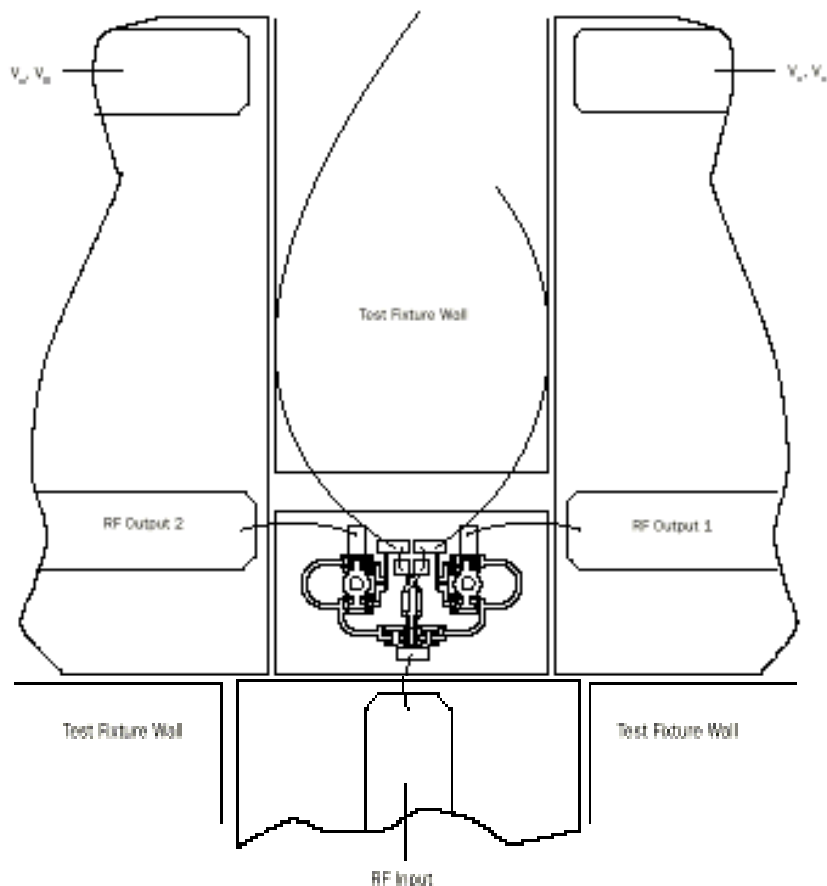

RF connections: Bond using one 1-mil diameter, 35-mil-maximum-length gold wire at both RF Input and RF Output ports for optimum RF performance.

Low-loss path is RF Input to RF Output 1 for V_1 and $V_2 = -5$ V, V_3 and $V_4 = 0$. Low-loss path is RF Input to RF Output 2 for V_1 and $V_3 = 0$, V_2 and $V_4 = -5$ V.

RF isolation will be limited by the chip operating environment.

MECHANICAL DRAWING

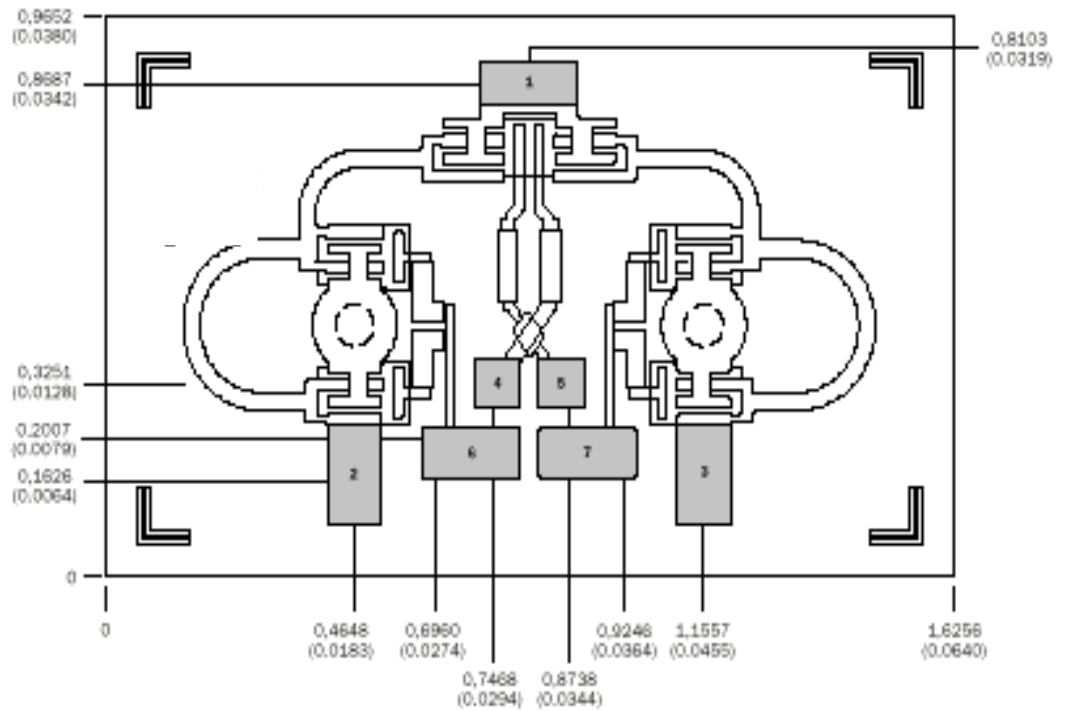

Units: Millimeters (inches)

Thickness: 0.1524 (0.006)

Chip-edge-to-bond-pad dimensions are shown to center of bond pad.

Chip size \pm 0.0508 (0.002)

Bond pad #1 (RF Input):	0.1930 x 0.0762 (0.0076 x 0.0030)
Bond pad #2 (RF Output 1):	0.1067 x 0.1803 (0.0042 x 0.0071)
Bond pad #3 (RF Output 2):	0.1067 x 0.1803 (0.0042 x 0.0071)
Bond pad #4 (V_1):	0.0914 x 0.0914 (0.0036 x 0.0036)
Bond pad #5 (V_2):	0.0914 x 0.0914 (0.0036 x 0.0036)
Bond pad #6 (V_3):	0.1930 x 0.0889 (0.0076 x 0.0035)
Bond pad #7 (V_4):	0.1930 x 0.0889 (0.0076 x 0.0035)

GaAs MMIC devices are susceptible to damage from Electrostatic Discharge. Proper precautions should be observed during handling, assembly and test.