

July 17, 1991

www.DataSheet4U.com

**SPECIFICATION OF
FIGARO GAS SENSOR TGS 880**
=====

FIGARO ENGINEERING INC.

www.DataSheet4U.com

1. PRODUCT NAME

FIGARO GAS SENSOR TGS 880

2. STRUCTURAL SPECIFICATIONS

2-1. STRUCTURE AND DIMENSIONS

Subject to the attached drawing. (Drawing No.S0101-00)

2-2. EXPLOSION PROOF

A spark which breaks out inside the cover cannot ignite an explosion outside of the cover.

2-3. MARK OF PRODUCTION LOT

Production lot number is imbedded with four numbers and alphabets.

Example;

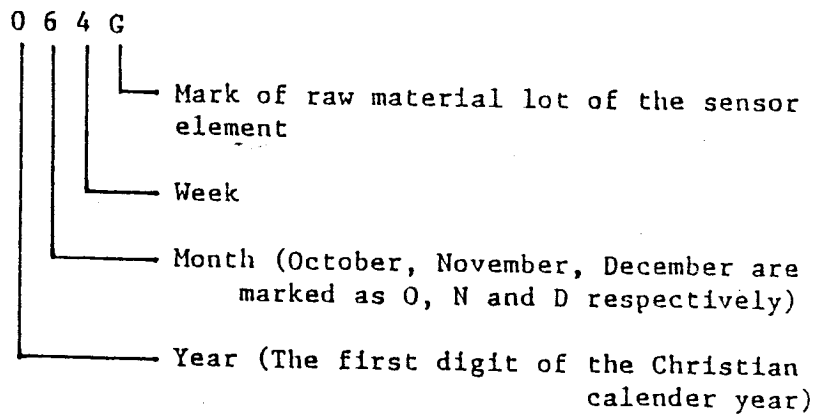

www.DataSheet4U.com

3. MECHANICAL STRENGTH SPECIFICATIONS

3-1. VIBRATION

The sensor has enough structural strength such as non lead-wire break down against the following vibration.

- * Frequency: 1,000 cpm
- * Total Amplitude: 4 mm
- * Direction: X,Y,Z, axes

3-2. SHOCK

The sensor has enough mechanical strength such as non lead-wire break down even after being dropped 5 times from a height of 50 cm onto a plank of cedar or pine wood (3 cm thick) laid on a concrete floor or after being shocked 5 times with 100G.

3-3. BINDING STRENGTH

The flame proof cover is binded to the base with a ring. The binding strength is more than 10Kg.

3-4. WITHDRAWAL FORCE

The pins can withstand a withdrawal force in excess of 5Kg in the pins direction.

4. CIRCUIT SPECIFICATIONS

4-1. OPERATION RATINGS

Heater Voltage(V_H) : $5.0V \pm 0.2V$
Circuit Voltage(V_C) : Max. 24V
Sensor Power Dissipation(P_S) : Max. 15mW

4-2. HEATER RESISTANCE

$30\Omega \pm 3\Omega$ at room temperature.

4-3. INSULATION RESISTANCE

The resistance between the electrodes of the heater and element shows more than $1M\Omega$ when supplied with 100V DC and the heater is supplied with a rated voltage.

5. CHARACTERISTIC SPECIFICATIONS

5-1. SENSOR RESISTANCE IN AIR

$R_s(\text{Air})$ is the sensor resistance in STANDARD CONDITION OF FRESH AIR in the environment where Figaro is located.

$R_s(\text{Air})$ satisfies the following relation.

$$10K\Omega \leq R_s(\text{Air}) \leq 100K\Omega$$

5-2. SENSOR RESISTANCE RATIO

The ratio between the sensor resistances for 50 ppm, $R_s(50)$, and 300 ppm, $R_s(300)$, of ethanol-vapor satisfies the following relation under the STANDARD TEST CONDITIONS.

$$0.4 \leq \frac{R_s(300)}{R_s(50)} \leq 0.6$$

5-3. INITIAL ACTION TIME

The sensors, which were previously energized under the REFERENCE ATMOSPHERE, are stored without power under the REFERENCE TEMPERATURE AND HUMIDITY for three weeks.

Subsequently, the sensors are re-energized under STANDARD TEST CONDITIONS except PRE-HEATING CONDITION and have the resistance, $R_s(0)$, according to the following relation within 2 minutes after power-on.

$$R_s(0) \geq R_s(50)$$

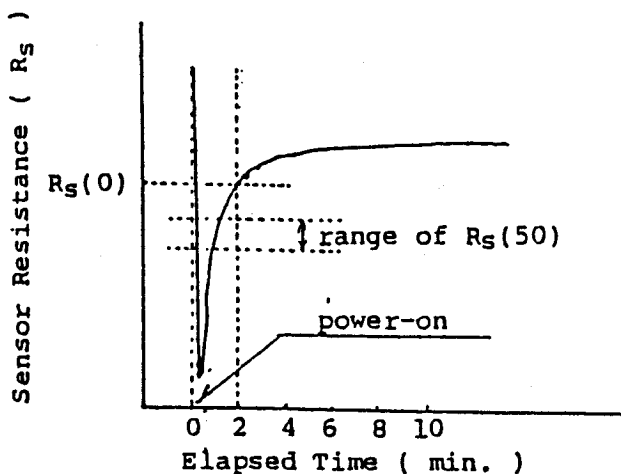

5-4. RESPONSE

Upon being exposed to 50 ppm of ethyl alcohol vapor, the sensor resistance decreases within 16 seconds to 90% of the variation between $R_s(\text{air-b})$ and $R_s(50)$. $R_s(\text{air-b})$ means the sensor resistance before ethyl alcohol exposure.

After removal from the gas to clean air, the sensor resistance increases within 30 seconds to more than 90% of the variation between $R_s(\text{air-a})$ and $R_s(50)$.

$R_s(\text{air-a})$ means the sensor resistance in clean air after ethyl alcohol exposure.

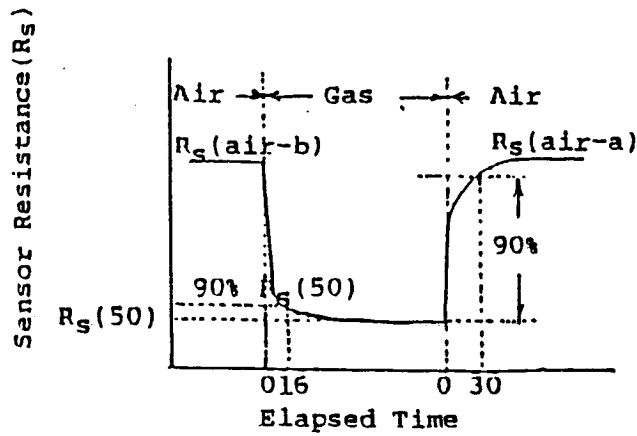

6. APPENDICES

6-1. STANDARD TEST CONDITIONS

STANDARD TEST CONDITIONS are defined according to the following three conditions.

A. BASIC MEASURING CIRCUIT

The sensor is evaluated according to the following circuit and standard circuit conditions in Table II.

The sensor characteristics are evaluated with the sensor resistance "Rs", converted from output voltage (VRL) with the help of the following equation.

$$R_s = \frac{V_c \times R_L}{V_{RL}} - R_L$$

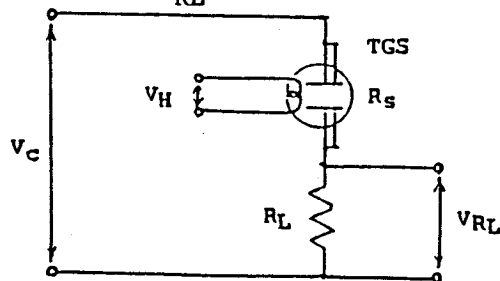

V_c : Circuit Voltage
V_H : Heater Voltage
R_L : Load Resistance
R_s : Sensor Resistance

Table II Standard Circuit Condition

$$V_c = 10.0 \pm 0.1V$$

$$V_H = 5.0 \pm 0.05 V$$

$$R_L = 4.0K\Omega \pm 2\%$$

B. REFERENCE ATMOSPHERE

REFERENCE ATMOSPHERE is defined as clean air under the atmospheric conditions of a temperature of $20^\circ\text{C} \pm 2^\circ\text{C}$ and relative humidity of $65\% \pm 5\%$.

C. PRE-HEATING

The sensor is evaluated after the power supply according to the BASIC CIRCUIT for 168hrs under REFERENCE ATMOSPHERE.

PRE-HEATING is defined as the above mentioned power-supply.

www.DataSheet4U.com 6-2. REFERENCE TEMPERATURE AND HUMIDITY

Temperature is 20°C + 10°C.
Humidity is 65% + 20% as relative humidity.

6-3. MEASURING CHAMBER

The chamber for the sensor's evaluation has an interior capacity of more than 1 liter per sensor.

6-4. ADJUSTMENT OF VAPOR CONCENTRATION

Vapor concentration is subject to the volumetric method specified below.

The highest grade reagent of ethyl alcohol is used.
According to the formula below, required amount of liquid is vaporized in the MEASURING CHAMBER.

$$x = \frac{M \times C}{22.4 \times d \times p} \times \frac{273}{273 + t}$$

x: liquid alcohol amount (μl)
c: vaporized alcohol capacity (ml)
M: molecular weight of alcohol (46.07)
d: specific gravity of alcohol
Note: $d^{20} = 0.797$
p: purity of reagent
t: temperature(°C)

In case of measuring two concentrations(ex. 50'ppm and 300 ppm of ethyl alcohol), higher concentration is measured after the low concentration measurement by increasing the gas concentration.

6-5. GAS CONCENTRATION CHECK

Gas concentration is identified with a gas chromatograph.

6-6. MEASUREMENT METHOD

Measurement value is defined as the output voltage after the following sequence.

- * The sensor is energized in the measurement chamber.
- * A certain amount of alcohol is injected into the chamber.
- * Atmosphere is stirred for 30 seconds.
- * The atmosphere is left for 100 seconds.

Regarding the response-measurement specified in 5-4, after adjusting the alcohol concentration, the sensor is put immediately into the chamber then output voltage of the sensor is measured.

6-7. AMENDMENT

This PRODUCT SPECIFICATIONS shall be amended upon mutual deliberation when the amendment is necessary.

S 0101-00

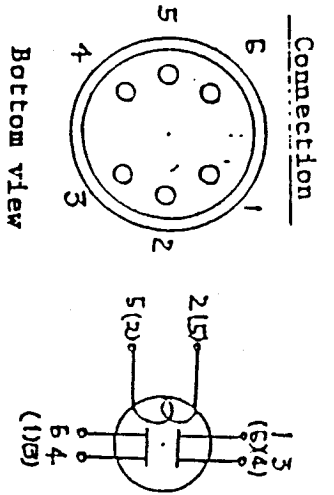
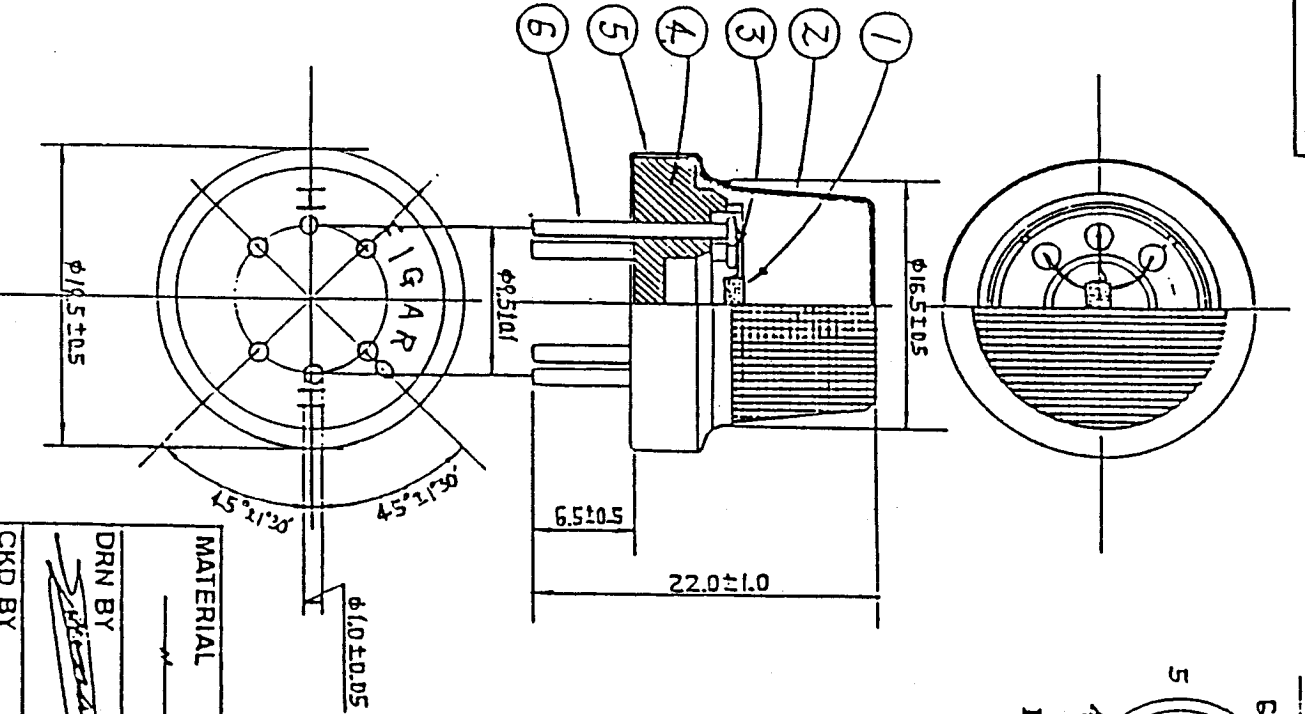

Heater Pins : Pin Nos. 2 and 5
 Electrode Pin Nos. 1, 3, 4 and 6
 Pins numbered 1 and 3 are connected internally. Pins numbered 4 and 6 are connected internally.

Number	Name	Material etc.
1.	Sensor Stainless Steel Gauze	SnO ₂ -x as main component in conformity to SUS 316-2W, JISZ-8801. Normal Dimensions: 149μm. Double Mesh.
3.	Heater Coil Base	Chrome alloy wire, φ = 0.06mm. Class Fiber reinforced polyamide resin.
5.	Ring	BSR-0, thickness: 0.2mm. Nickel-coated.
6.	Pin	Nickel

REVISIONS	

MATERIAL	TOLERANCE	FIGARO ENGINEERING INC.
DRN BY <i>[Signature]</i>	SCALE 2/1	DISCRPTION TGS 880
CKD BY	DATE March 1, 1987	DRAWING NUMBER S0101-00