



DIGITAL I²C HUMIDITY AND TEMPERATURE SENSOR

Version No.	Revisions	Date
V1.0	First released version	2013.05
V1.1	Modify the current part	2013.08

DIGITAL I²C HUMIDITY AND TEMPERATURE SENSOR

Features

- Relative Humidity Sensor
 - ± 4.5 % RH (maximum @ 20–80% RH)
- Temperature Sensor
 - ±0.5 °C accuracy (typical)
 - ±1 °C accuracy (maximum @ 0 to 70 °C)
- 0 to 100% RH operating range
- –40 to +85 °C (GM) or 0 to +70 °C operating range (FM)
- Wide operating voltage range (2.1 to 3.6 V)
- Low Power Consumption
 - 240 µA during RH conversion
- I²C host interface
- Integrated on-chip heater
- Excellent long term stability
- Factory calibrated
- Optional factory-installed cover
 - Low-profile
 - Protection during reflow
 - Excludes liquids and particulates (hydrophobic/oleophobic)

Applications

- Industrial HVAC/R
- Thermostats/humidistats
- Respiratory therapy
- White goods
- Micro-environments/data centers
- Automotive climate control and de-fogging
- Asset and goods tracking

Description

The TH02 is a digital relative humidity and temperature sensor. This monolithic CMOS IC integrates temperature and humidity sensor elements, an analog-to-digital converter, signal processing, calibration data, and an I²C host interface. The patented use of industry-standard, low-K polymeric dielectrics for sensing humidity enables the construction of a low-power, monolithic CMOS sensor IC with low drift and hysteresis and excellent long term stability.

Both the temperature and humidity sensors are factory-calibrated and the calibration data is stored in the on-chip non-volatile memory. This ensures that the sensors are fully interchangeable, with no recalibration or software changes required.

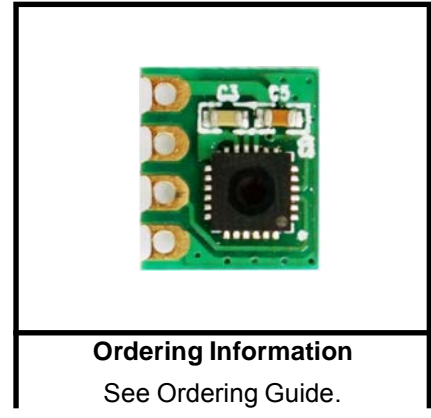

Patent protected; patents pending

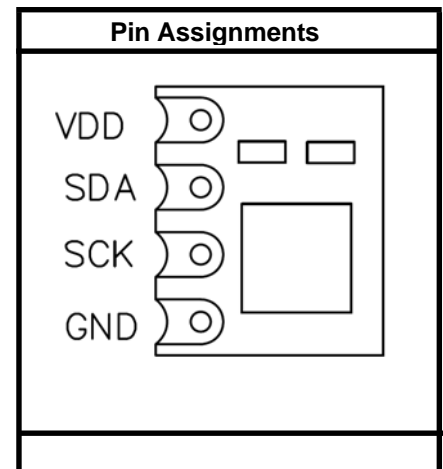

TABLE OF CONTENTS

<u>Section</u>	<u>Page</u>
1. Electrical Specifications	4
2. Functional Description	8
2.1. Overview	8
2.2. Relative Humidity Sensor Accuracy	9
2.3. Linearization	11
2.4. Temperature Compensation	12
2.5. Hysteresis	12
2.6. Prolonged Exposure to High Humidity	12
2.7. Soldering	13
2.8. Protecting the Sensor	14
2.9. Bake/Hydrate Procedure	14
2.10. Long Term Drift/Aging	14
3. Host Interface	15
3.1. I2C Interface	15
3.2. I2C Operation	19
4. TH02 Connection Diagrams	21
5. Control Registers	22
5.1. Register Detail (Defaults in bold)	22
6. Pin Descriptions: TH02	25

1. Electrical Specifications

Unless otherwise specified, all min/max specifications apply over the recommended operating conditions.

Table 1. Recommended Operating Conditions

Parameter	Symbol	Test Condition	Min	Typ	Max	Unit
Power Supply	V_{DD}		2.1	3.3	3.6	V
Operating Temperature	T_A	G grade	-40	—	85	°C
Operating Temperature	T_A	F grade	0	—	70	°C

Table 2. General Specifications

$2.1 \leq V_{DD} \leq 3.6$ V; $T_A = 0$ to 70 °C (F grade) or -40 to 85 °C (G grade) unless otherwise noted.

Parameter	Symbol	Test Condition	Min	Typ	Max	Unit
Input Voltage High	V_{IH}	SCL, SDA pins	$0.7 \times V_{DD}$	—	—	V
Input Voltage Low	V_{IL}	SCL, SDA pins	—	—	$0.3 \times V_{DD}$	V
Input Voltage Range	V_{IN}	SCL, SDA pins with respect to GND	0.0	—	3.6	V
Input Leakage	I_{IL}	SCL, SDA pins	—	—	± 1	μA
Output Voltage Low	V_{OL}	SDA pin; $I_{OL} = 8.5$ mA; $V_{DD} = 3.3$ V	—	—	0.6	V
		SDA pin; $I_{OL} = 3.5$ mA; $V_{DD} = 2.1$ V	—	—	0.4	V
Notes:						
1. SDA and SCL pins have an internal 75 k Ω pull-up resistor to VDD						

Table 3. General Specifications (Continued)
 $2.1 \leq V_{DD} \leq 3.6 \text{ V}$; $T_A = 0 \text{ to } 70 \text{ }^\circ\text{C}$ (F grade) or $-40 \text{ to } 85 \text{ }^\circ\text{C}$ (G grade) unless otherwise noted.

Parameter	Symbol	Test Condition	Min	Typ	Max	Unit
Power Consumption	I_{DD}	RH conversion in progress	—	240	560	μA
		Temperature conversion in progress	—	320	565	μA
		Average for 1 temperature and 1 RH conversion / minute	—	1	—	μA
		No conversion in progress; $V_{DD} = 3.3 \text{ V}$; $\text{SDA} = \text{SCL} \geq V_{IH}$	—	150	—	μA
Conversion Time	t_{CONV}	14-bit temperature; 12-bit RH (Fast = 0)		35	40	ms
		13-bit temperature; 11-bit RH (Fast = 1)		18	21	
Power Up Time	t_{PU}	From $V_{DD} \geq 2.1\text{V}$ to ready for a temp/RH conversion		10	15	ms
Notes:						
1. SDA and SCL pins have an internal 75 k Ω pull-up resistor to VDD						

Table 4. I²C Interface Specifications*

2.1 ≤ V_{DD} ≤ 3.6 V; T_A = 0 to 70 °C (F grade) or -40 to +85 °C (G grade) unless otherwise noted.

Parameter	Symbol	Test Condition	Min	Typ	Max	Unit
Hysteresis	V _{HYS}	High-to-low versus low-to-high transition	0.05 x V _{DD}	—	—	V
SCLK Frequency	f _{SCL}		—	—	400	kHz
SCL high time	t _{SKH}		0.6	—	—	μs
SCL low time	t _{SKL}		1.3	—	—	μs
Start hold time	t _{STH}		0.6	—	—	μs
Start setup time	t _{STS}		0.6	—	—	μs
Stop setup time	t _{SPS}		0.6	—	—	μs
Bus free time	t _{BUF}	Between Stop and Start	1.3	—	—	μs
SDA setup time	t _{DS}		100	—	—	ns
SDA hold time	t _{DH}		100	—	—	ns
SDA valid time	t _{VD;DAT}	From SCL low to data valid	—	—	0.9	μs
SDA acknowledge valid time	t _{VD;ACK}	From SCL low to data valid	—	—	0.9	μs

***Note:** All values are referenced to V_{IL} and/or V_{IH}.

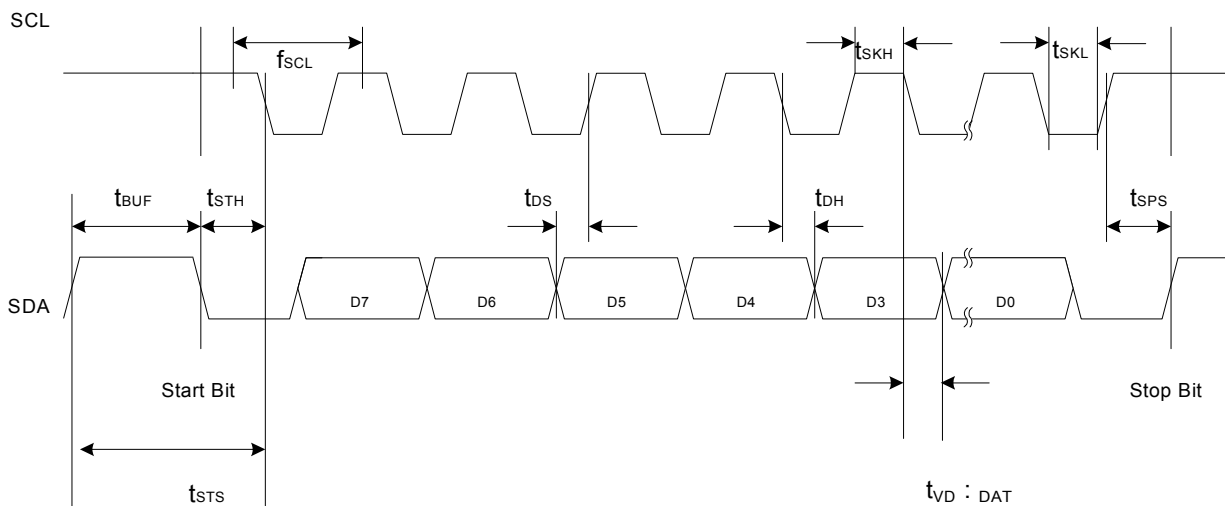

Figure 1. I²C Interface Timing Diagram

Table 5. Humidity Sensor
 $2.1 \leq V_{DD} \leq 3.6 \text{ V}; T_A = 25 \text{ }^\circ\text{C}; t_{CONV} = 35 \text{ ms}$ unless otherwise noted.

Parameter	Symbol	Test Condition	Min	Typ	Max	Unit
Operating Range ¹		Non-condensing	0	—	100	%RH
Resolution ²			—	—	12	bit
Accuracy ^{3,4}		20–80% RH	—	±3.0	—	%RH
		0–100% RH	See Figure 2			
Repeatability—Noise			—	0.05	—	%RH RMS
Response Time ⁵	τ 63%	1 m/s airflow	—	8	—	s
Hysteresis			—	±1	—	%RH
Long Term Stability ⁴			—	≤0.25	—	%RH/yr

Notes:

- Recommended humidity operating range is 20 to 80% RH (non-condensing) over 0 to 60 °C. Prolonged operation beyond these ranges may result in a shift of sensor reading, with slow recovery time.
- The TH02 has a nominal output of 16 codes per %RH, with 0h0000 = –24%RH.
- Excludes hysteresis, long term drift, and certain other factors and is applicable to non-condensing environments only. See section “4.2. Relative Humidity Sensor Accuracy” for more details.
- May be impacted by dust, vaporized solvents or other contaminants, e.g., out-gassing tapes, adhesives, packaging materials, etc. See section “4.10. Long Term Drift/Aging”.
- Time for sensor output to reach 63% of its final value after a step change.

Table 6. Temperature Sensor
 $2.1 \leq V_{DD} \leq 3.6 \text{ V}; T_A = 0 \text{ to } 70 \text{ }^\circ\text{C}$ (F grade) or $-40 \text{ to } +85 \text{ }^\circ\text{C}$ (G grade); $t_{CONV} = 35 \text{ ms}$ unless otherwise noted.

Parameter	Symbol	Test Condition	Min	Typ	Max	Unit
Operating Range			–40	—	85	°C
Resolution ¹			—	—	14	Bit
			—	—	1/32	°C
Accuracy ²		Typical at 25 °C	—	±0.5	—	°C
		Maximum	See Figure 3.			°C
Repeatability—Noise			—	0.1	—	°C RMS
Response Time ³		Time to reach 63% of final value	—	1.5	—	s
Long Term Stability			—	<0.05	—	°C/yr

Notes:

1. The TH02 has a nominal output of 32 codes /°C, with 0000 = -50 °C
2. Temperature sensor accuracy is for $V_{DD} = 2.3$ to 3.6 V.
3. Actual response times will vary dependent on system thermal mass and air-flow.

Table 7. Absolute Maximum Ratings^{1,2}

Parameter	Symbol	Test Condition	Min	Typ	Max	Unit
Ambient Temperature under Bias			-55	—	125	°C
Storage Temperature			-65	—	150	°C
Voltage on SDA or SCL pin with respect to GND			-0.3	—	3.9	V
—						
Voltage on V_{DD} with respect to GND			-0.3	—	4.2	V

Notes:

1. Absolute maximum ratings are stress ratings only; operation at or beyond these conditions is not implied and may shorten the life of the device or alter its performance.
2. For best accuracy, after removal from the sealed shipping bags, the TH02 should be stored in climate controlled conditions (10 to 35 °C, 20 to 60 %RH). Exposure to high temperature and/or high humidity environments can cause a small upwards shift in RH readings.

2. Functional Description

2.1. Overview

The TH02 is a digital relative humidity and temperature sensor. This monolithic CMOS IC integrates temperature and humidity sensor elements, an analog-to-digital converter, signal processing, calibration data, and an I²C host interface. Both the temperature and humidity sensors on each unit are factory-calibrated and the calibration data is stored in the on-chip non-volatile memory. This ensures that the sensors are fully interchangeable, with no recalibration or software changes required.

While the TH02 is largely a conventional mixed-signal CMOS integrated circuit, relative humidity sensors in general and those based on capacitive sensing using polymeric dielectric have unique application and use requirements that are not common to conventional (non-sensor) ICs. Chief among those are:

- The need to protect the sensor during board assembly, i.e., solder reflow, and the need to subsequently rehydrate the sensor.
- The need to protect the sensor from damage or contamination during the product life-cycle
- The impact of prolonged exposure to extremes of temperature and/or humidity and their potential affect on sensor accuracy
- The effects of humidity sensor "memory"
- The need to apply temperature correction and linearization to the humidity readings

Each of these items is discussed in more detail in the following sections.

2.2. Relative Humidity Sensor Accuracy

To determine the accuracy of a relative humidity sensor, it is placed in a temperature and humidity controlled chamber. The temperature is set to a convenient fixed value (typically 30 °C) and the relative humidity is swept from 20 to 80% and back to 20% in the following steps: 20% – 40% – 60% – 80% – 80% – 60% – 40% – 20%. At each set-point, the chamber is allowed to settle for a period of 30 minutes before a reading is taken from the sensor. Prior to the sweep, the device is allowed to stabilize to 50%RH. The solid top and bottom (blue) trace in Figure 2, “Measuring Sensor Accuracy Including Hysteresis,” shows the result of a typical sweep after non-linearity compensation.

Figure 2. Measuring Sensor Accuracy Including Hysteresis

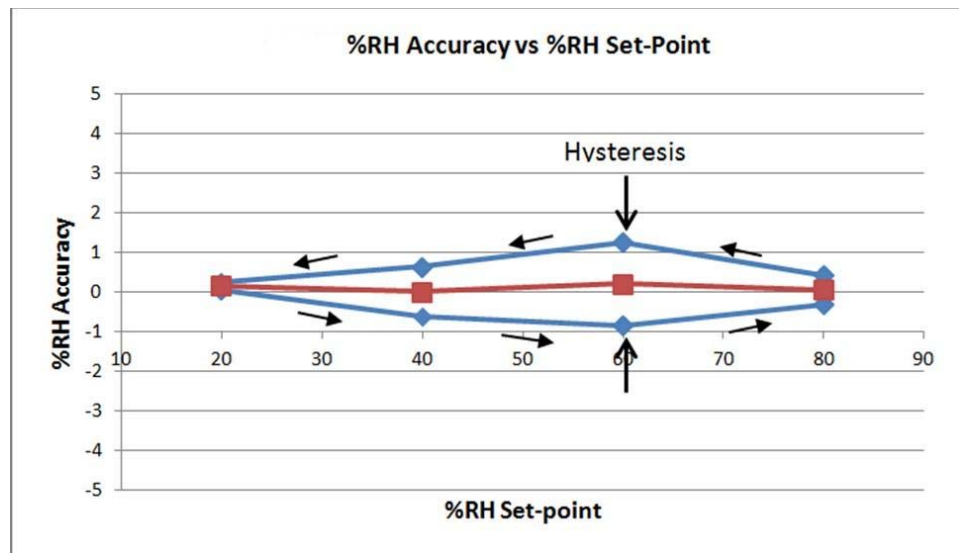

The RH accuracy is defined as the center (red) line shown in Figure 2, which is the average of the two data points at each relative humidity set-point. In this case, the sensor shows an accuracy of 0.25%RH. The TH02 accuracy specification includes:

- Unit-to-unit and lot-to-lot variation in non-linearity compensation
- Accuracy of factory calibration
- Margin for shifts that can occur during solder reflow (compensation for shift due to reflow is included in the linearization procedure below). The accuracy specification does not include:
 - Hysteresis (typically $\pm 1\%$)
 - Effects from long term exposure to very humid conditions
 - Contamination of the sensor by particulates, chemicals, etc.
 - Other aging related shifts ("Long-term stability")
 - Variations due to temperature. After application of temperature compensation, RH readings will typically vary by less than $\pm 0.05\%/^{\circ}\text{C}$.

2.3. Linearization

Capacitive relative humidity sensors require linearization. The TH02 accuracy specification applies after correction of non-linearity errors. The recommended linearization technique is to correct the measured relative humidity value with a 2nd order polynomial; the linear relative humidity (RH) value is calculated as follows:

$$RH_{\text{Linear}} = RH_{\text{Value}} - ((RH_{\text{Value}})^2 \times A_2 + RH_{\text{Value}} \times A_1 + A_0)$$

Where:

- RH_{Linear} is the corrected relative humidity value in %RH
- RH_{Value} is the uncorrected (measured) relative humidity value in %RH
- A_2 , A_1 , and A_0 are unit-less correction coefficients derived through characterization of TH02s their values depend on whether compensation for a typical solder reflow is required

The values for the correction coefficients are shown in Table 8.

Table 8. Linearization Coefficients

Coefficient	Value
A_0	-4.7844
A_1	0.4008
A_2	-0.00393

2.4. Temperature Compensation

The TH02 relative humidity sensor is calibrated at a temperature of 30 °C; it is at this temperature that the sensor will give the most accurate relative humidity readings. For relative humidity measurements at other temperatures, the RH reading from the TH02 must be compensated for the change in temperature relative to 30 °C. Temperature compensated relative humidity readings can be calculated as follows:

$$RH_{TempCompensated} = RH_{Linear} + (Temperature - 30) \times (RH_{Linear} \times Q_1 + Q_0)$$

Where:

- $RH_{TempCompensated}$ is the temperature compensated relative humidity value in %RH.
- RH_{Linear} is the linear corrected relative humidity value in %RH.
- Temperature is the ambient temperature in °C as measured by the TH02 on chip temperature sensor.
 - Q_1 and Q_0 are unit-less correction coefficients derived through characterization of TH02s

This temperature compensation is most accurate in the range of 15–50 °C. The values for the correction coefficients are shown in Table 9.

Table 9. Linearization Coefficients

Coefficient	Value
Q_0	0.1973
Q_1	0.00237

2.5. Hysteresis

The moisture absorbent film (polymeric dielectric) of the humidity sensor will carry a memory of its exposure history, particularly its recent or extreme exposure history. A sensor exposed to relatively low humidity will carry a negative offset relative to the factory calibration, and a sensor exposed to relatively high humidity will carry a positive offset relative to the factory calibration. This factor causes a hysteresis effect illustrated by the top and bottom (blue) traces in Figure 7. The hysteresis value is the difference in %RH between the maximum absolute error on the decreasing humidity ramp and the maximum absolute error on the increasing humidity ramp at a single relative humidity Setpoint and is expressed as a bipolar quantity relative to the average, the center (red) trace in Figure 7. In the case of Figure 7, the measurement uncertainty due to the hysteresis effect is ±1.05%RH.

2.6. Prolonged Exposure to High Humidity

Prolonged exposure to high humidity will result in a gradual upward drift of the RH reading. The shift in sensor reading resulting from this drift will generally disappear slowly under normal ambient conditions. The amount of shift is proportional to the magnitude of relative humidity and the length of exposure. In the case of lengthy exposure to high humidity, some of the resulting shift may persist indefinitely under typical conditions. It is generally possible to substantially reverse this affect by baking the device.

2.7. Soldering

TH02 devices are shipped, like most ICs, vacuum-packed with an enclosed desiccant to avoid any drift during storage as well as to prevent any moisture-related issues during solder reflow. Devices should be soldered using reflow and a “no clean” solder process, as a water or solvent rinse after soldering will affect accuracy. PCB Land Pattern and Solder Mask Design” for the recommended card reflow profile.

The measured humidity value will generally shift slightly after solder reflow. This shift is accounted for when using the linearization procedure given above. After soldering, TH02 should be allowed to equilibrate under controlled RH conditions (room temperature, 45–55%RH) for at least 48 hours to reach rated accuracy. During soldering, it is recommended that a protective cover of some kind be in place. Kapton®* polyimide tape is recommended as a protective cover.

Alternatively, TH02s may be ordered with a factory fitted, solder-resistant protective cover which can be left in place for the lifetime of the product, preventing liquids, dust or other contaminants from coming into contact with the polymer sensor film. Ordering Guide” for a list of ordering part numbers that include the cover.

Hot air rework is not recommended. Soldering iron touch up is possible if flux is not needed and care is taken to avoid excessive heating. If rework is required, remove the part by hot air and solder a new part by reflow. Use only no-clean solder. Do not use solder resin or post-solder solvent cleanse.

2.8. Protecting the Sensor

Because the sensor operates on the principal of measuring a change in capacitance, any changes to the dielectric constant of the polymer film will be detected as a change in relative humidity. Therefore, it is important to minimize the probability of contaminants coming into contact with the sensor. Dust and other particles as well as liquids can affect the RH reading. It is recommended that a filter cover is employed in the end system that blocks contaminants but allows water vapor to pass through. Depending on the needs of the application, this can be as simple as plastic or metallic gauze for basic protection against particulates or something more sophisticated such as a hydrophobic membrane providing up to IP67 compliant protection.

TH02s may be ordered with a factory fitted, solder-resistant cover, which can be left in place for the lifetime of the product. It is very low-profile, hydrophobic and oleophobic, and excludes particulates down to 0.35 microns in size. See "Ordering Guide" for a list of ordering part numbers that include the cover. A dimensioned drawing of the IC with the cover is included in section. The sensor should be protected from direct sunlight to prevent heating effects as well as possible material degradation.

2.9. Bake/Hydrate Procedure

After exposure to extremes of temperature and/or humidity for prolonged periods, the polymer sensor film can become either very dry or very wet, in each case the result is either high or low relative humidity readings. Under normal operating conditions, the induced error will diminish over time. From a very dry condition, such as after shipment and soldering, the error will diminish over a few days at typical controlled ambient conditions, e.g., 48 hours of $45 \leq \%RH \leq 55$. However, from a very wet condition, recovery may take significantly longer. To accelerate recovery from a wet condition, a bake and hydrate cycle can be implemented. This operation consists of the following steps:

- Baking the sensor at 125 °C for ≥ 12 hours
- Hydration at 30 °C in 75 %RH for ≥ 10 hours

Following this cycle, the sensor will return to normal operation in typical ambient conditions after a few days.

2.10. Long Term Drift/Aging

Over long periods of time, the sensor readings may drift due to aging of the device. Standard accelerated life testing of the TH02 has resulted in the specifications for long-term drift. This contribution to the overall sensor accuracy accounts only for the long-term aging of the device in an otherwise benign operating environment and does not include the affects of damage, contamination, or exposure to extreme environmental conditions.

3. Host Interface

3.1. I²C Interface

The TH02 has an I²C serial interface with a 7-bit address of 0x40. The TH02 is a slave device supporting data transfer rates up to 400 kHz. Table 24 shows the register summary of the TH02.

3.1.1. Performing a Relative Humidity Measurement

The following steps should be performed in sequence to take a relative humidity measurement:

1. Set START (D0) in CONFIG to begin a new conversion
2. Poll RDY (D0) in STATUS (register 0) until it is low (= 0)
3. Read the upper and lower bytes of the RH value from DATAh and DATAl (registers 0x01 and 0x02), respectively. Table 10 shows the format of the 12-bit relative humidity result.
4. Convert the RH value to %RH using the following equation:

$$\%RH = \left(\frac{RH}{16} \right) - 24$$

where RH is the measured value returned in DATAh:DATAI

5. Apply temperature compensation and/or linearization as discussed elsewhere in this data sheet

Table 11 shows the 12-bit values that correspond to various measured RH levels.

Table 10. 12-Bit Relative Humidity Result Available in Registers 1 and 2

DATAh								DATAI							
D7	D6	D5	D4	D3	D2	D1	D0	D7	D6	D5	D4	D3	D2	D1	D0
12-Bit Relative Humidity Code												0	0	0	0

Table 11. Typical %RH Measurement Codes for 0 to 100% RH Range

%RH	12 Bit Code	
	Dec	Hex
0	384	180
10	544	220
20	704	2C0
30	864	360
40	1024	400
50	1184	4A0
60	1344	540
70	1504	5E0
80	1664	680
90	1824	720
100	1984	7C0

The above sequence assumes normal mode, i.e., $t_{CONV} = 35$ ms (typical). Conversions may be performed in fast mode. See section "5.1.3. Fast Conversion Mode".

3.1.2. Performing a Temperature Measurement

The following steps should be performed in sequence to take a temperature measurement:

6. Set START (D0) and TEMP (D4) in CONFIG (register 0x03) to begin a new conversion, i.e., write CONFIG with 0x11
7. Poll RDY (D0) in STATUS (register 0) until it is low (=0)
8. Read the upper and lower bytes of the temperature value from DATAh and DATAl (registers 0x01 and 0x02), respectively

Table 12 shows the format of the 14-bit temperature result. This value may be converted to °C using the following equation:

$$\text{Temperature}(^{\circ}\text{C}) = \left(\frac{\text{TEMP}}{32} \right) - 50$$

where TEMP is the measured value returned in DATAh:DATAI.

Table 13 shows the 14-bit values that correspond to various measured temperature levels.

Table 12. 14-Bit Temperature Result Available in Registers 1 and 2

DATAh								DATAI							
D7	D6	D5	D4	D3	D2	D1	D0	D7	D6	D5	D4	D3	D2	D1	D0
14-Bit Temperature Code														0	0

The above sequence assumes normal mode, i.e., $t_{\text{CONV}} = 35 \text{ ms}$ (typical). Conversions may be performed in fast mode. See section “5.1.3. Fast Conversion Mode”.

Table 13. Typical Temperature Measurement Codes for the –40 °C to 100 °C Range

Temp(°C)	14 Bit Code	
	Dec	Hex
–40	320	0140
–30	640	0280
–20	960	03C0
–10	1280	0500
0	1600	0640
10	1920	0780
20	2240	08C0
30	2560	0A00
40	2880	0B40
50	3200	0C80
60	3520	0DC0
70	3840	0F00
80	4160	1040
90	4480	1180
100	4800	12C0

3.1.3. Fast Conversion Mode

The time needed to perform a temperature or RH measurement can be reduced from 35 ms (typical) to 18 ms (typical) by setting FAST (D5) in CONFIG (register 0x03). Fast mode reduces the total power consumed during a conversion or the average power consumed by the TH02 when making periodic conversions. It also reduces the resolution of the measurements. Table 14 is a comparison of the normal and fast modes.

Table 14. Normal vs. Fast Mode

Parameter	Value	
	Normal Mode	Fast Mode
t _{CONV} (typical)	35 ms	18 ms
Temperature resolution	14-bit	13-bit
RH resolution	12-bit	11-bit

3.1.4. Heater

The TH02 relative humidity sensor contains an integrated, resistive heating element that may be used to raise the temperature of the humidity sensor. This element can be used to drive off condensation or to implement dew-point measurement when the TH02 is used in conjunction with a separate temperature sensor such as another TH02.

The heater can be activated by setting HEAT (D1) in CONFIG (register 0x03). Turning on the heater will reduce the tendency of the humidity sensor to accumulate an offset due to "memory" of sustained high humidity conditions. When the heater is enabled, the reading of the on-chip temperature sensor will be affected (increased).

3.1.5. Device Identification

The TH02 device and its revision level can be determined by reading ID (register 0x11). Table 15 lists the values for the various device revisions and may include revisions not yet in existence.

Table 15. Revision Values

Device ID Value		Device Type	Revision Level
D[7:4]	D[3:0]		
0101	0000	TH02	B

3.2. I²C Operation

The TH02 uses a digital I²C interface. If the TH02 shares an I²C bus with other slave devices, it should be powered down when the master controller is communicating with the other slave devices.

The format of the address byte is shown in Table 16.

Table 16. I²C Slave Address Byte

A6	A5	A4	A3	A2	A1	A0	R/W
1	0	0	0	0	0	0	1/0

3.2.1. I²C Write Operation

To write to a register on the TH02, the master should issue a start command (S) followed by the slave address, 0x40. The slave address is followed by a 0 to indicate that the operation is a write. Upon recognizing its slave address, the TH02 issues an acknowledge (A) by pulling the SDA line low for the high duration of the ninth SCL cycle. The next byte the master places on the bus is the register address pointer, selecting the register on the TH02 to which the data should be transferred. After the TH02 acknowledges this byte, the master places a data byte on the bus. This byte will be written to the register selected by the address pointer. The TH02 will acknowledge the data byte, after which the master issues a Stop command (P). See Table 17.

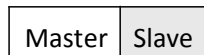

Table 17. I²C Write Sequence

Sequence to Write to a Register

S	Slave Address	W	A	Address Pointer	A	Register Data	A	P
---	---------------	---	---	-----------------	---	---------------	---	---

Sequence to Start a Relative Humidity Conversion

S	0x40	0	A	0x03	A	0x01	A	P
---	------	---	---	------	---	------	---	---

Sequence to Start a Temperature Conversion

S	0x40	0	A	0x03	A	0x11	A	P
---	------	---	---	------	---	------	---	---

3.2.2. I²C Read Operation

To read a register on the TH02, the master must first set the address pointer to indicate the register from which the data is to be transferred. Therefore, the first communication with the TH02 is a write operation. The master should issue a start command (S) followed by the slave address, 0x40. The slave address is followed by a 0 to indicate that the operation is a write. Upon recognizing its slave address, the TH02 will issue an acknowledge (A) by pulling the SDA line low for the high duration of the ninth SCL cycle. The next byte the master places on the bus is the register address pointer selecting the register on the TH02 from which the data should be transferred. After the TH02 acknowledges this byte, the master issues a repeated start command (Sr) indicating that a new transfer is to take place. The TH02 is addressed once again with the R/W bit set to 1, indicating a read operation. The TH02 will acknowledge its slave address and output data from the previously-selected register onto the data bus under the control of the SCL signal, the master should not acknowledge (\bar{A}) the data byte and issue a stop (P) command (see Table 18). However, if a RH or Temperature conversion result (two bytes) is to be read, the master should acknowledge (A) the first data byte and continue to activate the SCL signal. The TH02 will automatically output the second data byte. Upon receiving the second byte, the master should issue a not Acknowledge (\bar{A}) followed by a stop command. (See Table 19).

Table 18. I²C Read Sequence for a Single Register

Sequence to Read from a Single Register

S	Slave Address	W	A	Address Pointer	A	Sr	Slave Address	R	A	Register Data	\bar{A}	P
---	---------------	---	---	-----------------	---	----	---------------	---	---	---------------	-----------	---

Sequence to Read Device ID

S	0x40	0	A	0x11	A	Sr	0x40	1	A	ID	\bar{A}	P
---	------	---	---	------	---	----	------	---	---	----	-----------	---

Sequence to Read \overline{RDY} bit

S	0x40	0	A	0x00	A	Sr	0x40	1	A	—	RDY	\bar{A}	P
---	------	---	---	------	---	----	------	---	---	---	-----	-----------	---

Table 19. I²C Read Sequence for RH or Temperature Conversion Result

Sequence to Read Conversion Result

S	Slave Address	W	A	Address Pointer	A	Sr	Slave Address	R	A	Register 1 Data	A	Register 2 Data	\bar{A}	P
---	---------------	---	---	-----------------	---	----	---------------	---	---	-----------------	---	-----------------	-----------	---

S	0x40	0	A	0x01	A	Sr	0x40	1	A	Data H	A	Data L	\bar{A}	P
---	------	---	---	------	---	----	------	---	---	--------	---	--------	-----------	---

4 . TH02 Connection Diagrams

The TH02 is a simple-to-use device requiring a minimum of external components. Figure 2 shows the typical connection diagram for the TH02 connected to an MCU. The values for the two I²C pull-up resistors depend on the capacitance of the I²C bus lines and the desired speed of operation.

For ultra-low-power operation, such as in battery-powered applications. In this case, the TH02 is powered from one of the MCU's GPIOs. The GPIO can be driven high to powerup the TH02, once the measurement results are obtained, the GPIO can be driven low to power-down the TH02, reducing its current consumption to zero. The GPIO must be capable of sourcing 320 μ A for the duration of the conversion time (<200 ms for relative humidity and temperature conversions) and up to 40 mA for a period of 5 ms at power-up. The GPIO must also be capable of sinking up to 40 mA for a period of 5 ms at powerdown. If the GPIO is not capable of sourcing/sinking 40 mA, then the TH02 will take longer to powerup and powerdown.

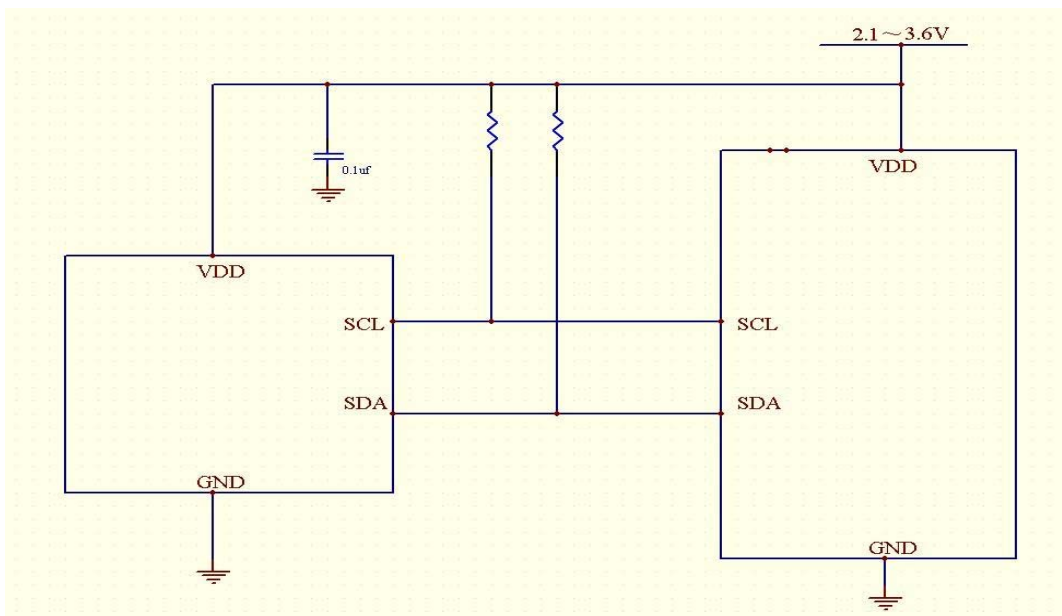

Figure 2. Recommended Connection Diagram for Low-Power Battery Operation

5. Control Registers

Table 20 contains a summary of the TH02 register set. Each register is described in more detail below.

Table 20. TH02 Register Summary

Register	Name	Bit 7	Bit 6	Bit 5	Bit 4	Bit 3	Bit 2	Bit 1	Bit 0
I ² C Register Summary									
0	STATUS	RSVD	RSVD	RSVD	RSVD	RSVD	RSVD	RSVD	/RDY
1	DATAh	Relative Humidity or Temperature, High Byte							
2	DATAI	Relative Humidity or Temperature, Low Byte							
3	CONFIG	RSVD	RSVD	FAST	TEMP	RSVD	RSVD	HEAT	START
17	ID	ID3	ID2	ID1	ID0	0	0	0	0
Notes: <ol style="list-style-type: none"> 1. Any register address not listed here is reserved and must not be written. 2. Reserved register bits (RSVD) must always be written as zero; the result of a read operation on these bits is undefined. 									

5.1. Register Detail (Defaults in bold)

Register 0. STATUS

Bit	D7	D6	D5	D4	D3	D2	D1	D0
Name								/RDY
Type	R							

Reset Settings = 0000_0001

Bit	Name	Function
7:1	Reserved	Reserved. Reads undefined.
0	/RDY	Ready. 0 = conversion complete; results available in DATAh:DATAI. 1 = conversion in progress.

Register 1. DATAh

Bit	D7	D6	D5	D4	D3	D2	D1	D0
Name	Relative Humidity or Temperature, High Byte							
Type	R							

Reset Settings = 0000_0000

Bit	Name	Function
7:0	DATAh	Data, High Byte. Eight most significant bits of a temperature or humidity measurement. See Table 14 or Table 16 for the measurement format.

Register 2. DATAI

Bit	D7	D6	D5	D4	D3	D2	D1	D0
Name	Relative Humidity or Temperature, Low Byte							
Type	Read							

Reset Settings = 0000_0000

Bit	Name	Function
7:0	DATAI	Data, Low Byte. Eight least significant bits of a temperature or humidity measurement. See Table 14 or Table 16 for the measurement format.

Register 3. CONFIG

Bit	D7	D6	D5	D4	D3	D2	D1	D0
Name			FAST	TEMP			HEAT	START
Type			R/W	R/W				R/W

Reset Settings = 0000_0000

Bit	Name	Function
7:6	Reserved	Reserved. Reads undefined. Always write as zero.
5	FAST	Fast Mode Enable. 0 = 35ms (typical) 1 = 18ms (typical)
4	TEMP	Temperature Enable. 0 = Relative humidity 1 = Temperature
3:2	Reserved	Reserved. Reads undefined. Always write as zero.
1	HEAT	Heater Enable. 0 = heater off 1 = heater on
0	START	Conversion Start. 0 = do not start a conversion 1 = start a conversion

Register 17. ID

Bit	D7	D6	D5	D4	D3	D2	D1	D0
Name	ID7	ID6	ID5	ID4	ID3	ID2	ID1	ID0
Type	R	R	R	R	R	R	R	R

Reset Settings = 0101_0000

Bit	Name	Function
7:0	ID	Identification. See section "5.1.5. Device Identification".

6. Pin Descriptions: TH02

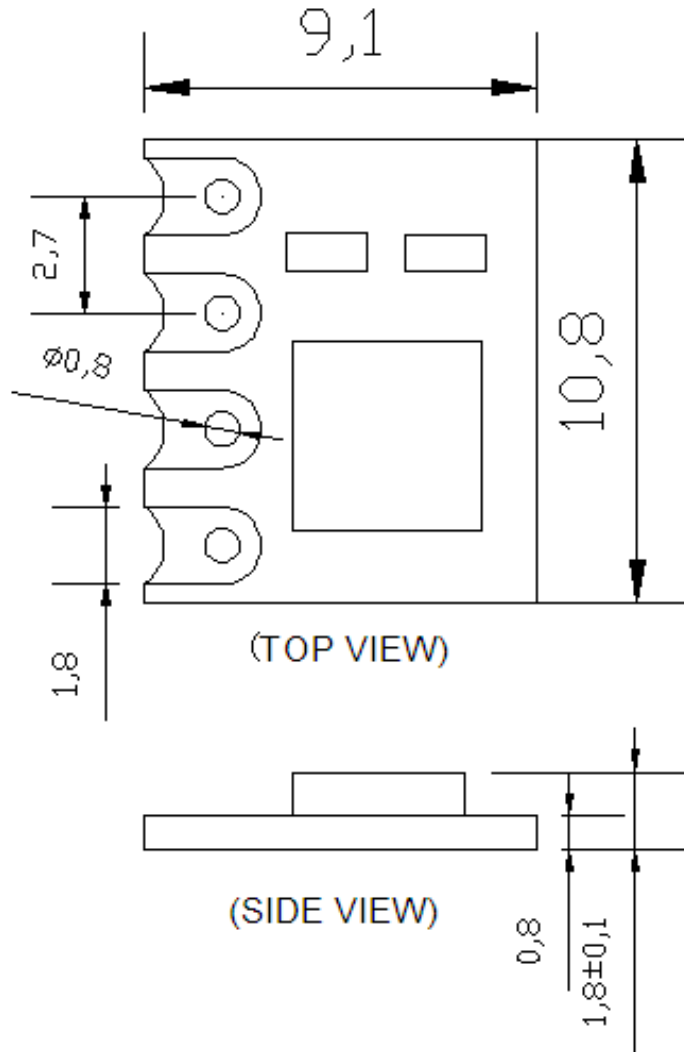

Mechanical Dimension (unit: mm)

Notes: General tolerance ± 0.1

HOPE MICROELECTRONICS CO.,LTD
Add: 2/F, Building 3, Pingshan Private
Enterprise Science and Technology
Park, Lishan Road, XiLi Town,
Nanshan District, Shenzhen,
Guangdong, China
Tel: 86-755-82973805
Fax: 86-755-82973550
Email: sales@hoperf.com
Website: <http://www.hoperf.com>
<http://www.hoperf.cn>

This document may contain preliminary information and is subject to change by Hope Microelectronics without notice. Hope Microelectronics assumes no responsibility or liability for any use of the information contained herein. Nothing in this document shall operate as an express or implied license or indemnity under the intellectual property rights of Hope Microelectronics or third parties. The products described in this document are not intended for use in implantation or other direct life support applications where malfunction may result in the direct physical harm or injury to persons. NO WARRANTIES OF ANY KIND, INCLUDING, BUT NOT LIMITED TO, THE IMPLIED WARRANTIES OF MECHANICALITY OR FITNESS FOR A PARTICULAR PURPOSE, ARE OFFERED IN THIS DOCUMENT.

©2006, HOPE MICROELECTRONICS CO.,LTD. All rights reserved.