

TOSHIBA MOS DIGITAL INTEGRATED CIRCUIT SILICON GATE CMOS

4 GBIT (512M × 8 BIT) CMOS NAND E²PROM**DESCRIPTION**

The TH58BVG2S3HBAI4 is a single 3.3V 4 Gbit (4,429,185,024 bits) NAND Electrically Erasable and Programmable Read-Only Memory (NAND E²PROM) organized as (2048 + 64) bytes × 64 pages × 4096 blocks. The device has a 2112-byte static register which allows program and read data to be transferred between the register and the memory cell array in 2112-bytes increments. The Erase operation is implemented in a single block unit (128 Kbytes + 4 Kbytes: 2112 bytes × 64 pages).

The TH58BVG2S3HBAI4 is a serial-type memory device which utilizes the I/O pins for both address and data input/output as well as for command inputs. The Erase and Program operations are automatically executed making the device most suitable for applications such as solid-state file storage, voice recording, image file memory for still cameras and other systems which require high-density non-volatile memory data storage.

The TH58BVG2S3HBAI4 has ECC logic on the chip and 8bit read errors for each 528Bytes can be corrected internally.

FEATURES

- Organization

Memory cell array	2112 × 128K × 8 × 2
Register	2112 × 8
Page size	2112 bytes
Block size	(128K + 4K) bytes
- Modes
 - Read, Reset, Auto Page Program, Auto Block Erase, Status Read, Page Copy, Multi Page Read, Multi Page Program, Multi Block Erase, ECC Status Read
- Mode control
 - Serial input/output
 - Command control
- Number of valid blocks
 - Min 4016 blocks
 - Max 4096 blocks
- Power supply
 - VCC = 2.7V to 3.6V
- Access time

Cell array to register	40 μs typ. (Single Page Read) / 55us typ. (Multi Page Read)
Serial Read Cycle	25 ns min (CL=50pF)
- Program/Erase time

Auto Page Program	330 μs/page typ.
Auto Block Erase	2.5 ms/block typ.
- Operating current

Read (25 ns cycle)	30 mA max.
Program (avg.)	30 mA max
Erase (avg.)	30 mA max
Standby	100 μA max
- Package
 - P-TFBGA63-0911-0.80CZ (Weight: 0.154 g typ.)
- 8bit ECC for each 528Byte is implemented on the chip.

PIN ASSIGNMENT (TOP VIEW)

	1	2	3	4	5	6	7	8	9	10
A	NC	NC							NC	NC
B	NC								NC	NC
C			\overline{WP}	ALE	V_{SS}	\overline{CE}	\overline{WE}	RY/ \overline{BY}		
D			NC	\overline{RE}	CLE	NC	NC	NC		
E			NC	NC	NC	NC	NC	NC		
F			NC	NC	NC	NC	NC	NC		
G			NC	NC	NC	NC	NC	NC		
H			NC	I/O1	NC	NC	NC	V_{CC}		
J			NC	I/O2	NC	V_{CC}	I/O6	I/O8		
K			V_{SS}	I/O3	I/O4	I/O5	I/O7	V_{SS}		
L	NC	NC							NC	NC
M	NC	NC							NC	NC

PIN NAMES

I/O1 to I/O8	I/O port
\overline{CE}	Chip enable
\overline{WE}	Write enable
\overline{RE}	Read enable
CLE	Command latch enable
ALE	Address latch enable
\overline{WP}	Write protect
RY/ \overline{BY}	Ready/Busy
V_{CC}	Power supply
V_{SS}	Ground
NC	No Connection

BLOCK DIAGRAM

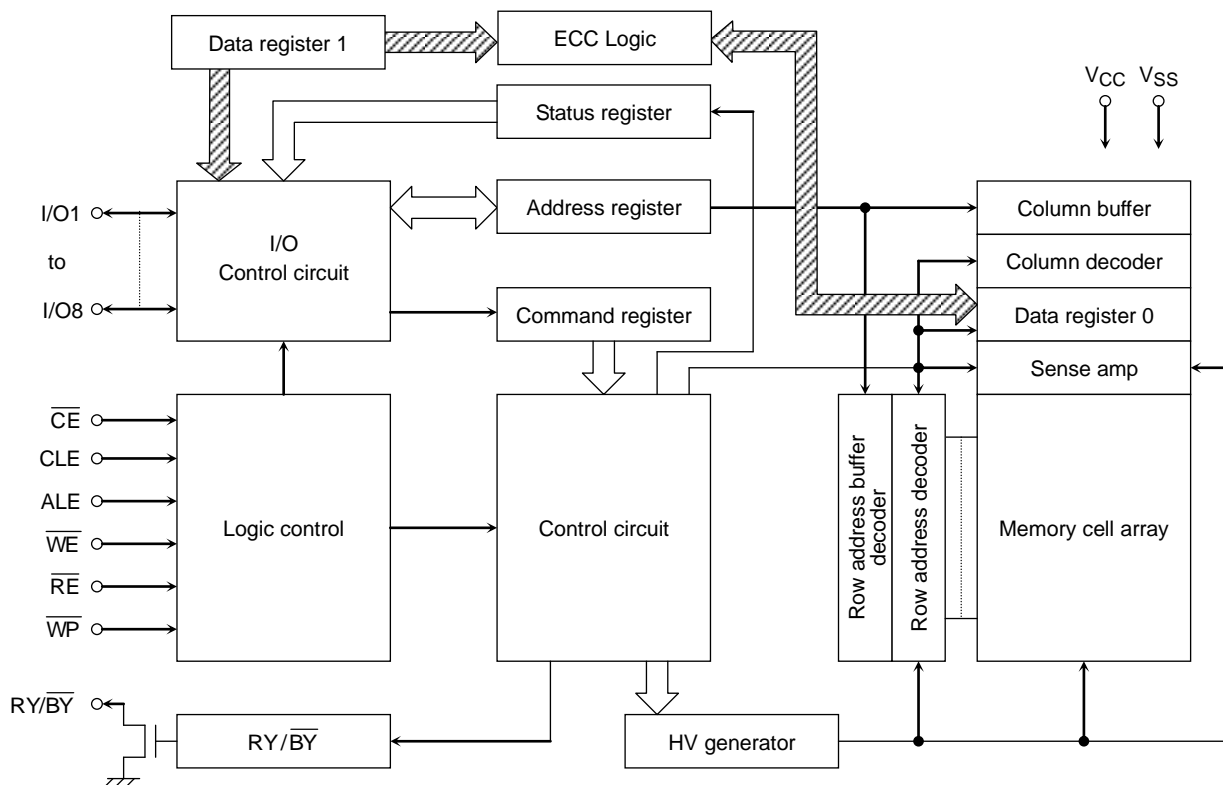

ABSOLUTE MAXIMUM RATINGS

SYMBOL	RATING	VALUE	UNIT
V _{CC}	Power Supply Voltage	-0.6 to 4.6	V
V _{IN}	Input Voltage	-0.6 to 4.6	V
V _{I/O}	Input /Output Voltage	-0.6 to V _{CC} + 0.3 (≤ 4.6 V)	V
P _D	Power Dissipation	0.3	W
T _{SOLDER}	Soldering Temperature (10 s)	260	°C
T _{STG}	Storage Temperature	-55 to 150	°C
T _{OPR}	Operating Temperature	-40 to 85	°C

CAPACITANCE *(Ta = 25°C, f = 1 MHz)

SYMBOL	PARAMETER	CONDITION	MIN	MAX	UNIT
C _{IN}	Input	V _{IN} = 0 V	—	20	pF
C _{OUT}	Output	V _{OUT} = 0 V	—	20	pF

* This parameter is periodically sampled and is not tested for every device.

VALID BLOCKS

SYMBOL	PARAMETER	MIN	TYP.	MAX	UNIT
N _{VB}	Number of Valid Blocks	4016	—	4096	Blocks

NOTE: The device occasionally contains unusable blocks. Refer to Application Note (13) toward the end of this document.

The first block (Block 0) is guaranteed to be a valid block at the time of shipment.

The specification for the minimum number of valid blocks is applicable over lifetime

The number of valid blocks is on the basis of single plane operations, and this may be decreased with two plane operations.

RECOMMENDED DC OPERATING CONDITIONS

SYMBOL	PARAMETER	MIN	TYP.	MAX	UNIT
V _{CC}	Power Supply Voltage	2.7	—	3.6	V
V _{IH}	High Level input Voltage	V _{CC} x 0.8	—	V _{CC} + 0.3	V
V _{IL}	Low Level Input Voltage	-0.3*	—	V _{CC} x 0.2	V

* -2 V (pulse width lower than 20 ns)

DC CHARACTERISTICS (T_a = -40 to 85°C, V_{CC} = 2.7 to 3.6V)

SYMBOL	PARAMETER	CONDITION	MIN	TYP.	MAX	UNIT
I _{IL}	Input Leakage Current	V _{IN} = 0 V to V _{CC}	—	—	±20	μA
I _{LO}	Output Leakage Current	V _{OUT} = 0 V to V _{CC}	—	—	±20	μA
I _{CCO1}	Serial Read Current	$\overline{CE} = V_{IL}$, I _{OUT} = 0 mA, t _{cycle} = 25 ns	—	—	30	mA
I _{CCO2}	Programming Current	—	—	—	30	mA
I _{CCO3}	Erasing Current	—	—	—	30	mA
I _{CCS}	Standby Current	$\overline{CE} = V_{CC} - 0.2 V$, $\overline{WP} = 0 V/V_{CC}$,	—	—	100	μA
V _{OH}	High Level Output Voltage	I _{OH} = -0.1 mA	V _{CC} - 0.2	—	—	V
V _{OL}	Low Level Output Voltage	I _{OL} = 0.1 mA	—	—	0.2	V
I _{OL} (R _Y / \overline{BY})	Output current of R _Y / \overline{BY} pin	V _{OL} = 0.2 V	—	4	—	mA

AC CHARACTERISTICS AND RECOMMENDED OPERATING CONDITIONS(Ta = -40 to 85°C, V_{CC} = 2.7 to 3.6V)

SYMBOL	PARAMETER	MIN	MAX	UNIT
t _{CLS}	CLE Setup Time	12	—	ns
t _{CLH}	CLE Hold Time	5	—	ns
t _{CS}	\overline{CE} Setup Time	20	—	ns
t _{CH}	\overline{CE} Hold Time	5	—	ns
t _{WP}	Write Pulse Width	12	—	ns
t _{ALS}	ALE Setup Time	12	—	ns
t _{ALH}	ALE Hold Time	5	—	ns
t _{DS}	Data Setup Time	12	—	ns
t _{DH}	Data Hold Time	5	—	ns
t _{WC}	Write Cycle Time	25	—	ns
t _{WH}	\overline{WE} High Hold Time	10	—	ns
t _{WW}	\overline{WP} High to \overline{WE} Low	100	—	ns
t _{RR}	Ready to \overline{RE} Falling Edge	20	—	ns
t _{RW}	Ready to \overline{WE} Falling Edge	20	—	ns
t _{RP}	Read Pulse Width	12	—	ns
t _{RC}	Read Cycle Time	25	—	ns
t _{REA}	\overline{RE} Access Time	—	20	ns
t _{CEA}	\overline{CE} Access Time	—	25	ns
t _{CLR}	CLE Low to \overline{RE} Low	10	—	ns
t _{AR}	ALE Low to \overline{RE} Low	10	—	ns
t _{RHOH}	\overline{RE} High to Output Hold Time	25	—	ns
t _{RLOH}	\overline{RE} Low to Output Hold Time	5	—	ns
t _{RHZ}	\overline{RE} High to Output High Impedance	—	60	ns
t _{CHZ}	\overline{CE} High to Output High Impedance	—	20	ns
t _{CSD}	\overline{CE} High to ALE or CLE Don't Care	0	—	ns
t _{REH}	\overline{RE} High Hold Time	10	—	ns
t _{IR}	Output-High-impedance-to- \overline{RE} Falling Edge	0	—	ns
t _{RHW}	\overline{RE} High to \overline{WE} Low	30	—	ns
t _{WHC}	\overline{WE} High to \overline{CE} Low	30	—	ns
t _{WHR}	\overline{WE} High to \overline{RE} Low	60	—	ns
t _{WB}	\overline{WE} High to Busy	—	100	ns
t _{RST}	Device Reset Time (Ready/Read/Program/Erase)	—	5/5/10/500	μs

*1: t_{CLS} and t_{ALS} can not be shorter than t_{WP}*2: t_{CS} should be longer than t_{WP} + 8ns.

AC TEST CONDITIONS

PARAMETER	CONDITION
	V_{CC} : 2.7 to 3.6V
Input level	$V_{CC}-0.2V$, 0.2V
Input pulse rise and fall time	3 ns
Input comparison level	$V_{CC} / 2$
Output data comparison level	$V_{CC} / 2$
Output load	C_L (50 pF) + 1 TTL

Note: Busy to ready time depends on the pull-up resistor tied to the $\overline{RY}/\overline{BY}$ pin.
(Refer to Application Note (9) toward the end of this document.)

PROGRAMMING / ERASING / READING CHARACTERISTICS

($T_a = -40$ to 85°C , $V_{CC} = 2.7$ to 3.6V)

SYMBOL	PARAMETER	MIN	TYP.	MAX	UNIT	NOTES
t_{PROG}	Average Programming Time (Single Page)	—	330	700	μs	
	Average Programming Time (Multi Page)	—	350	700	μs	
t_{DCBSYW1}	Busy Time in Multi Page Program(following 11h)	—	0.5	1	μs	
N	Number of Partial Program Cycles in the Same Page	—	—	4		(1)
t_{BERASE}	Block Erasing Time	—	2.5	5	ms	
t_{R}	Memory Cell Array to Starting Address (Single Page)	—	40	120	μs	
	Memory Cell Array to Starting Address (Multi Page)	—	55	200		

(1) Refer to Application Note (12) toward the end of this document.

Data Output

When t_{REH} is long, output buffers are disabled by $\overline{RE}=\text{High}$, and the hold time of data output depend on t_{RH0H} (25ns MIN). On this condition, waveforms look like normal serial read mode.

When t_{REH} is short, output buffers are not disabled by $\overline{RE}=\text{High}$, and the hold time of data output depend on t_{RLOH} (5ns MIN). On this condition, output buffers are disabled by the rising edge of \overline{CLE} , \overline{ALE} , \overline{CE} or falling edge of \overline{WE} , and waveforms look like Extended Data Output Mode.

TIMING DIAGRAMS

Latch Timing Diagram for Command/Address/Data

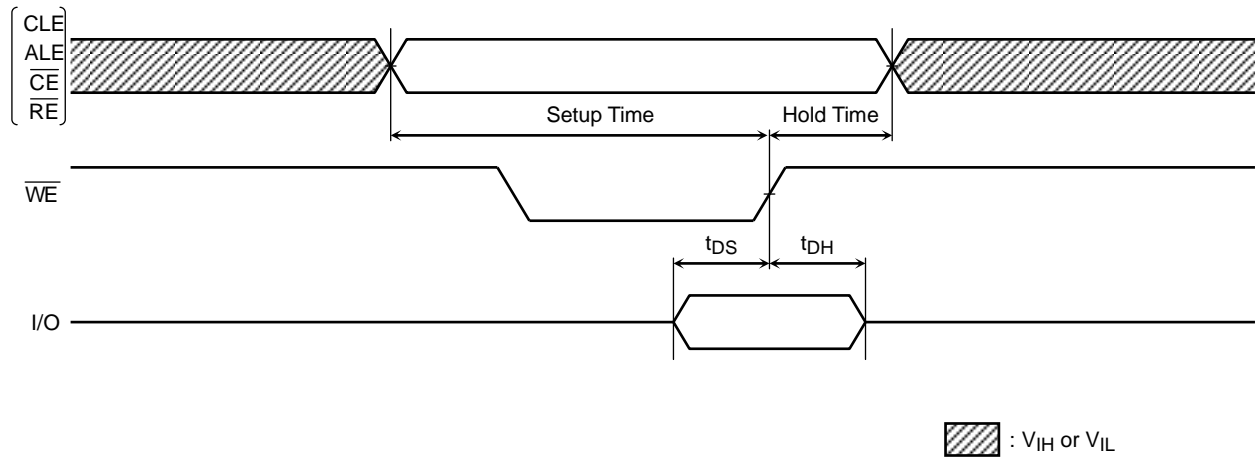

Command Input Cycle Timing Diagram

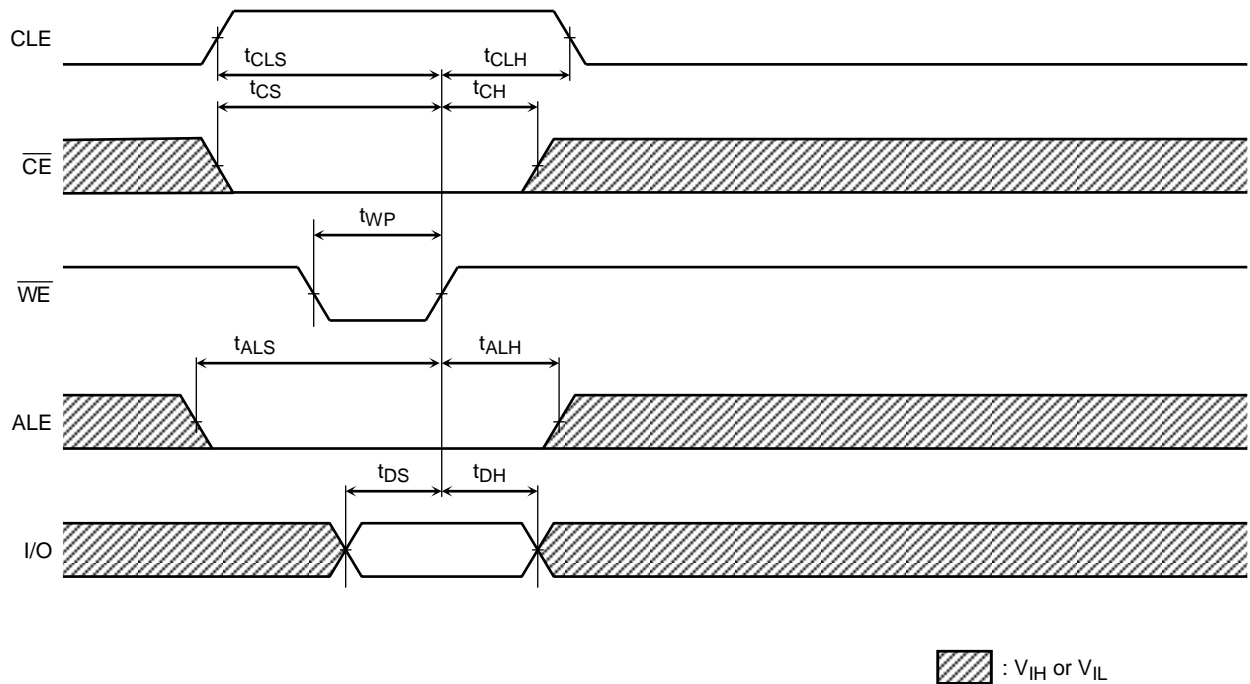

Address Input Cycle Timing Diagram

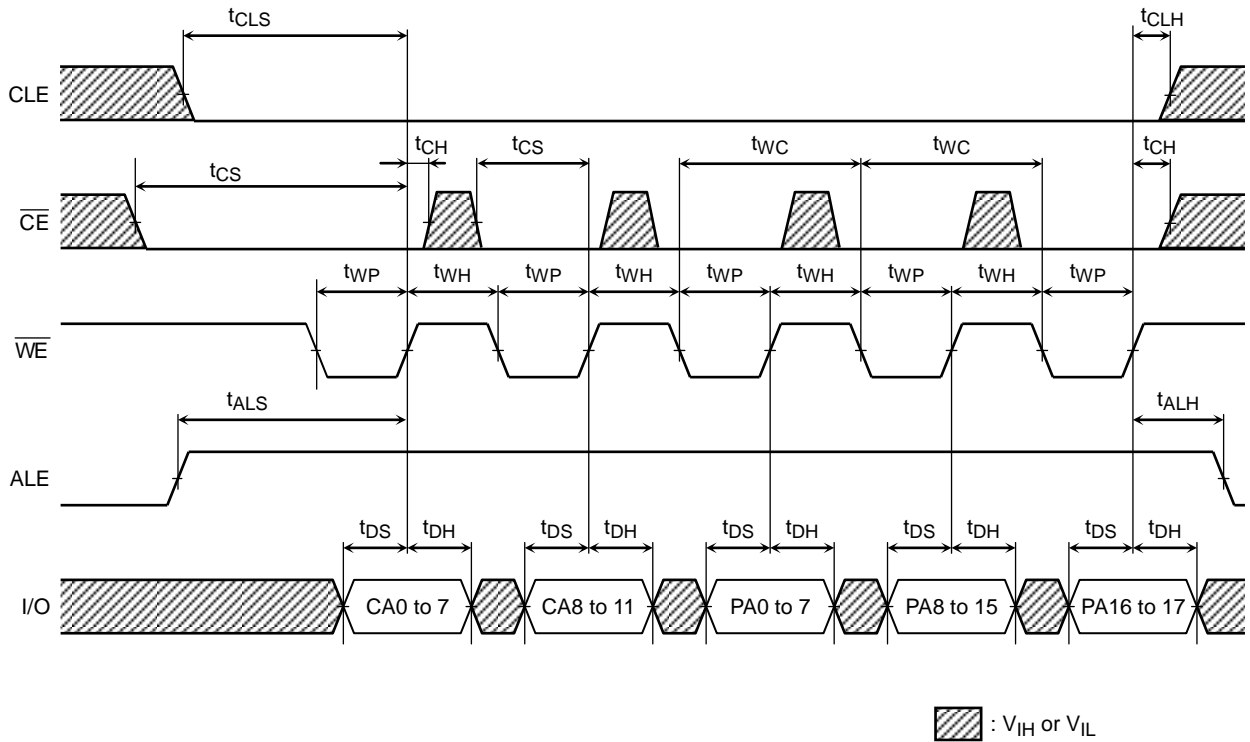

Data Input Cycle Timing Diagram

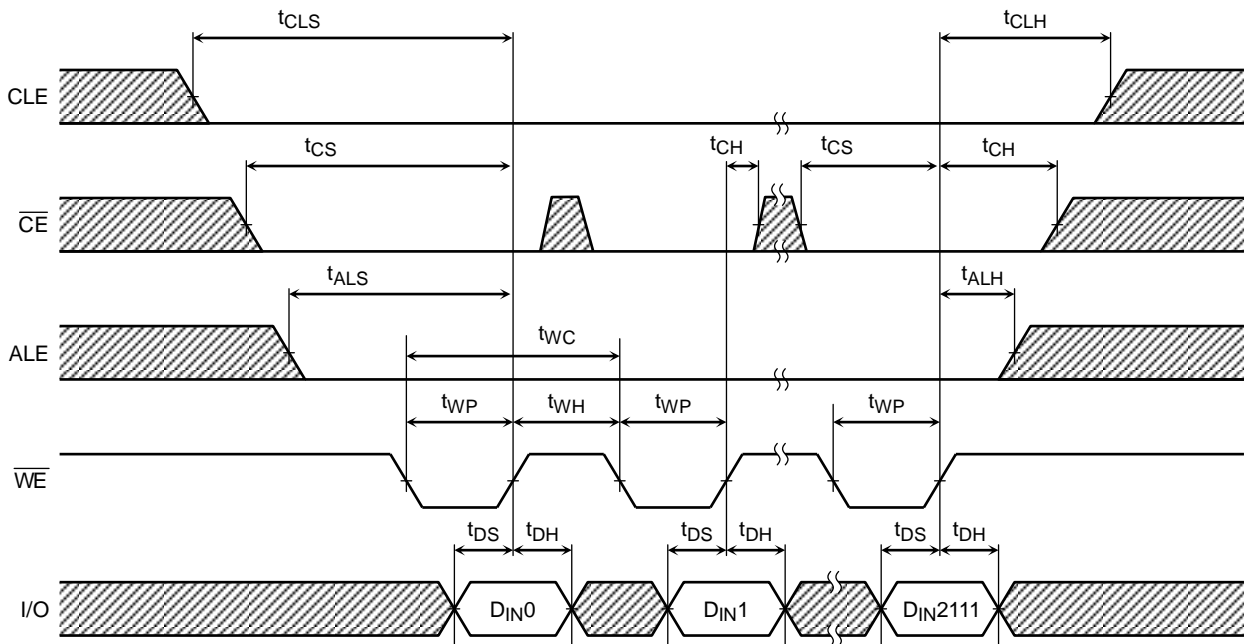

Serial Read Cycle Timing Diagram

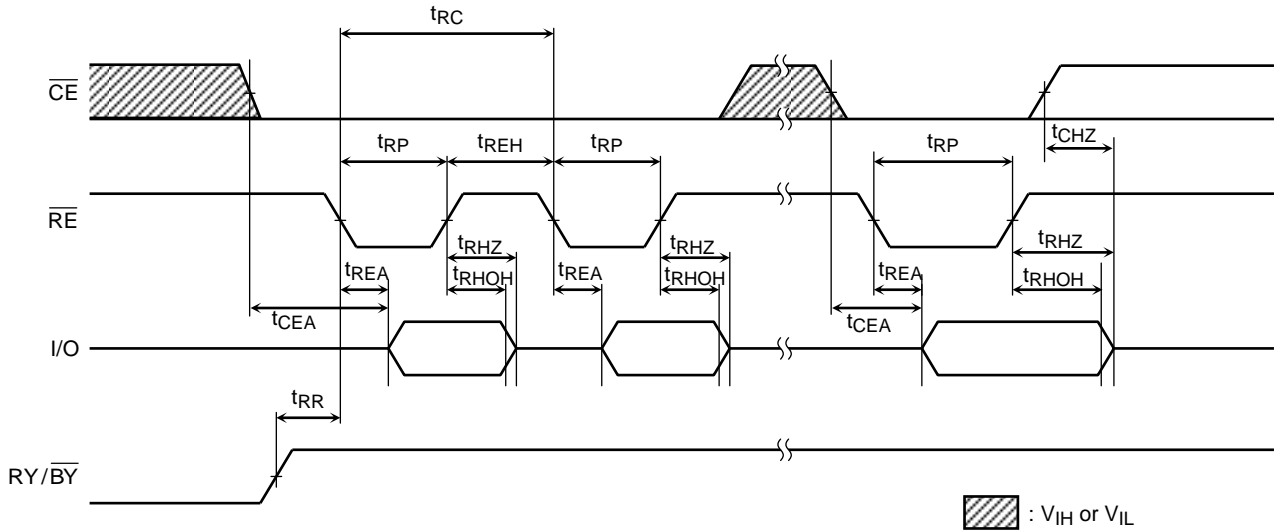

Status Read Cycle Timing Diagram

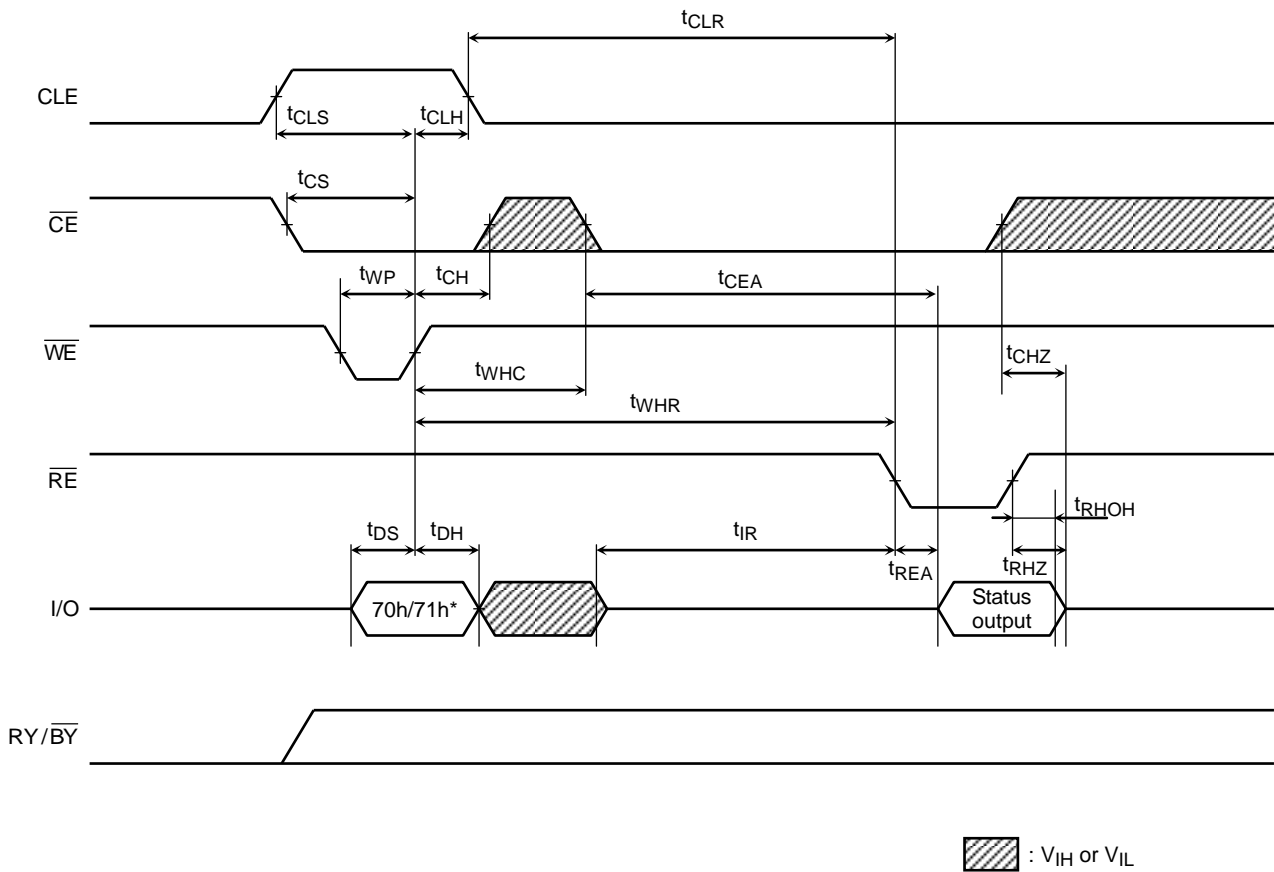

*: 70h/71h represents the hexadecimal number

ECC Status Read Cycle Timing Diagram

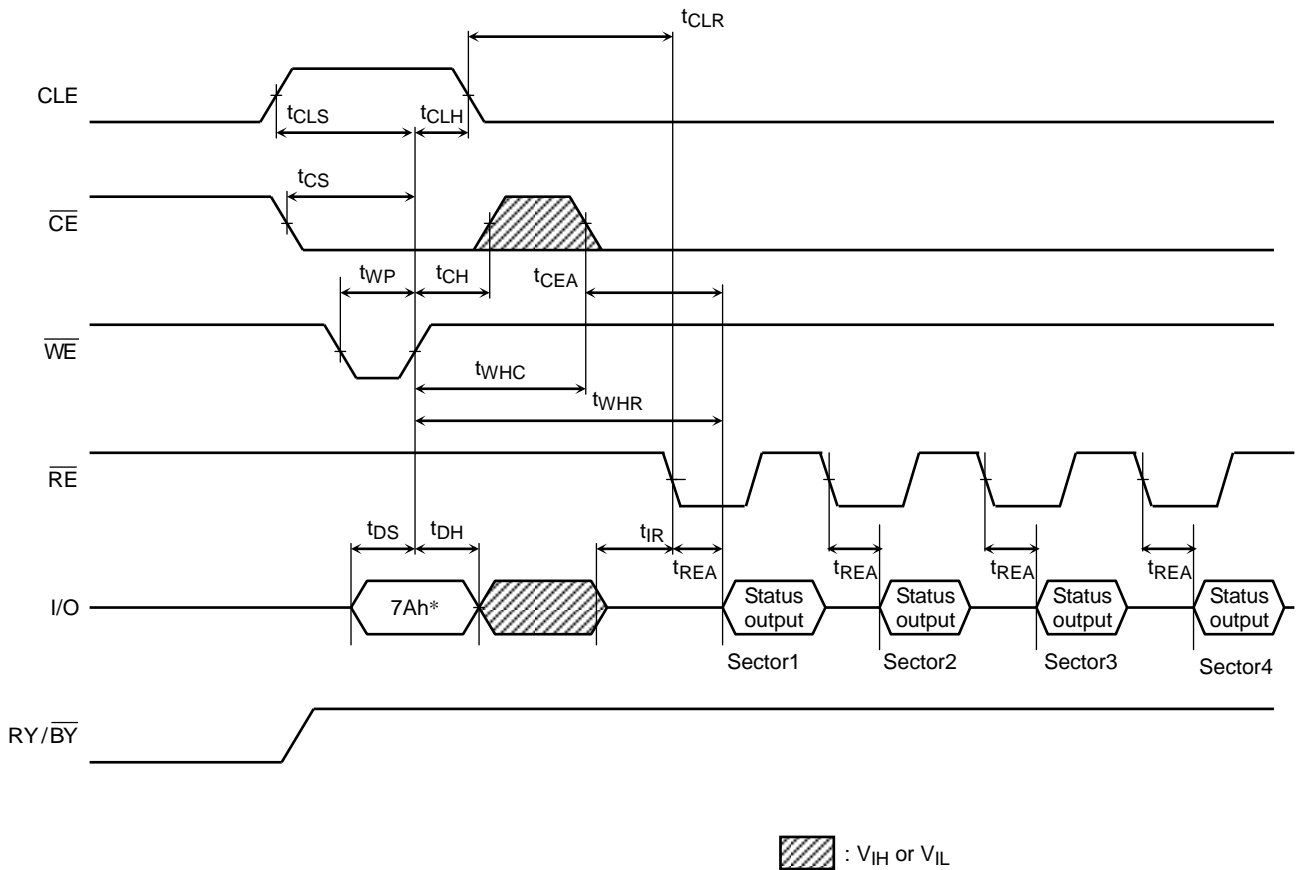

*: ECC Status output should be read for all 4 sector information.

** : $7Ah$ command can be inputted to the device from [after RY/ \overline{BY} returns to High] to [before Dout or Next command input].

Read Cycle Timing Diagram

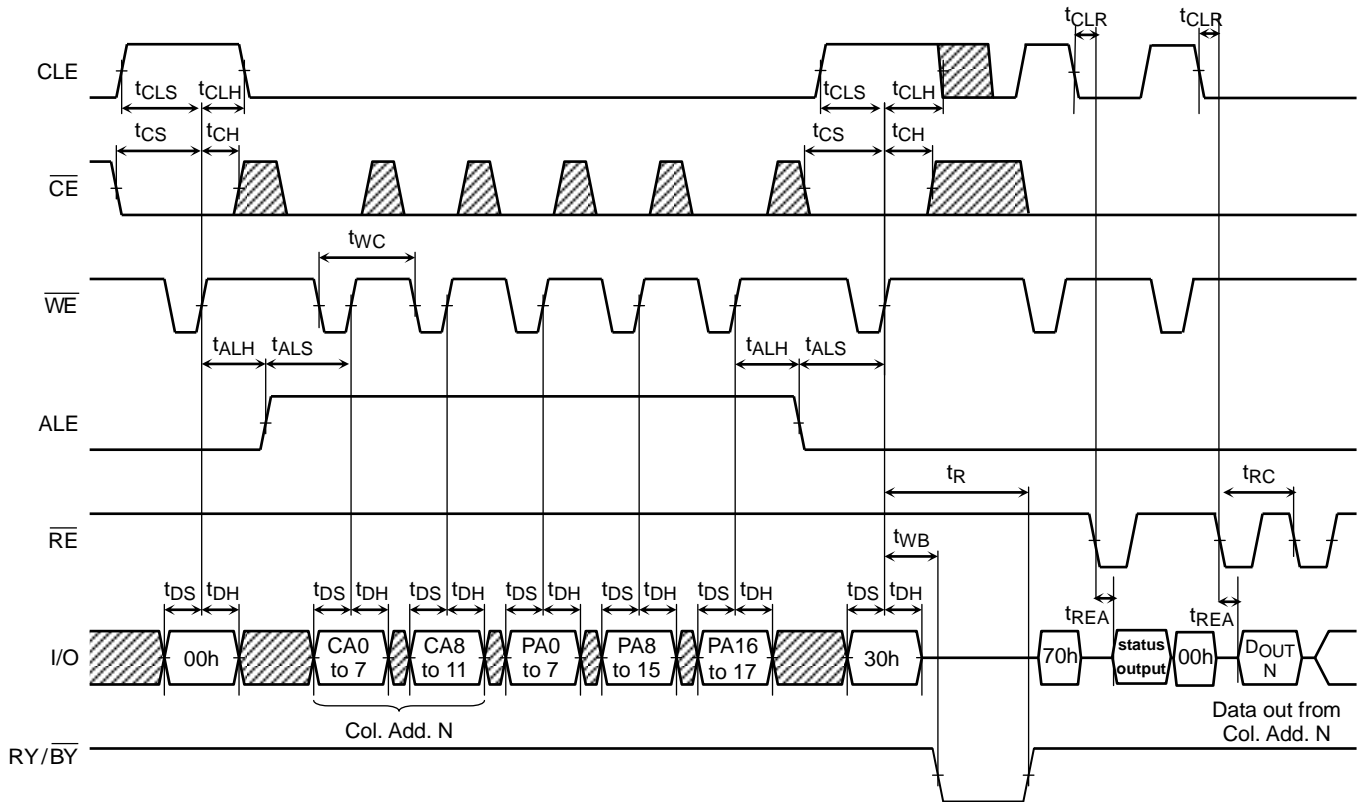

Read Cycle Timing Diagram: When Interrupted by \overline{CE}

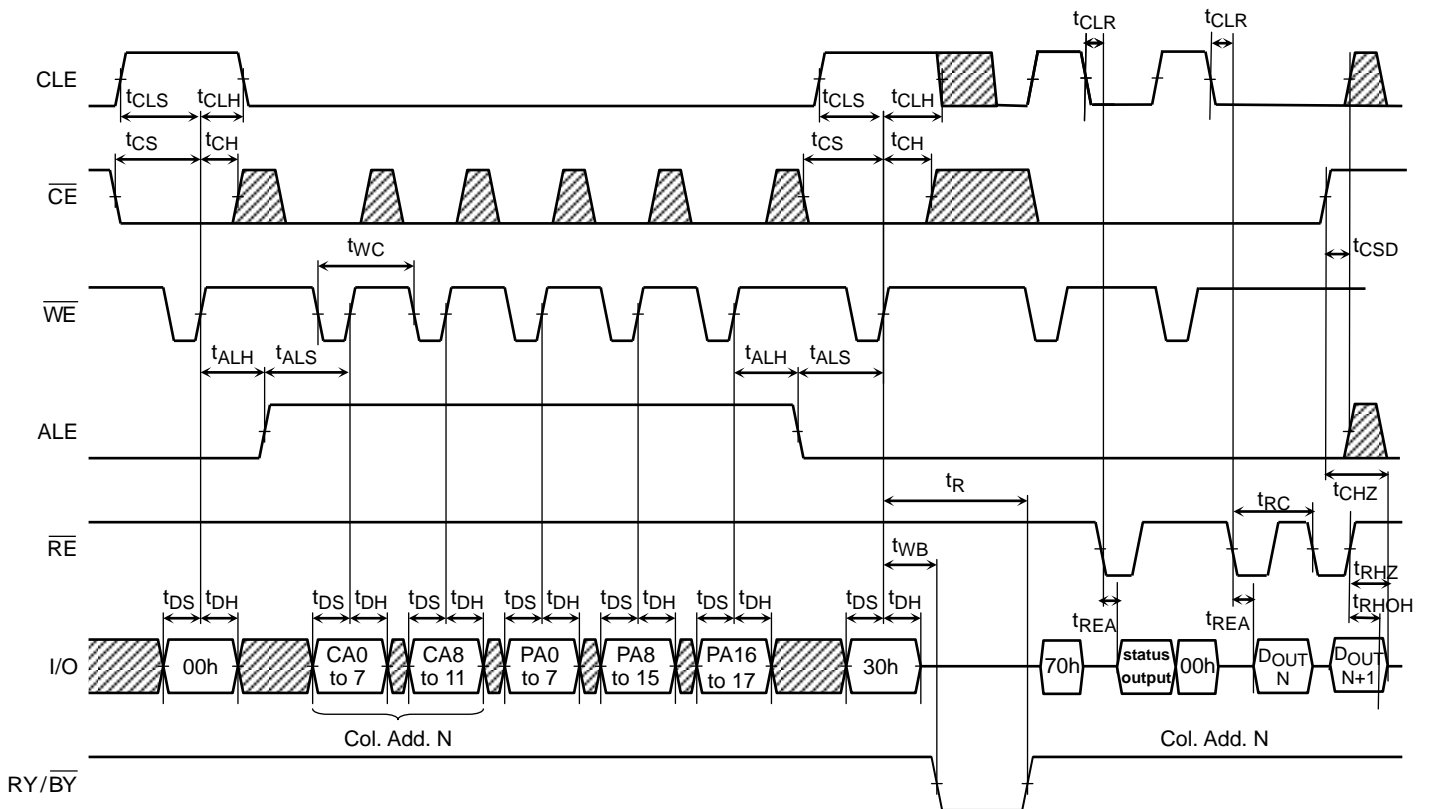

Column Address Change in Read Cycle Timing Diagram (1/2)

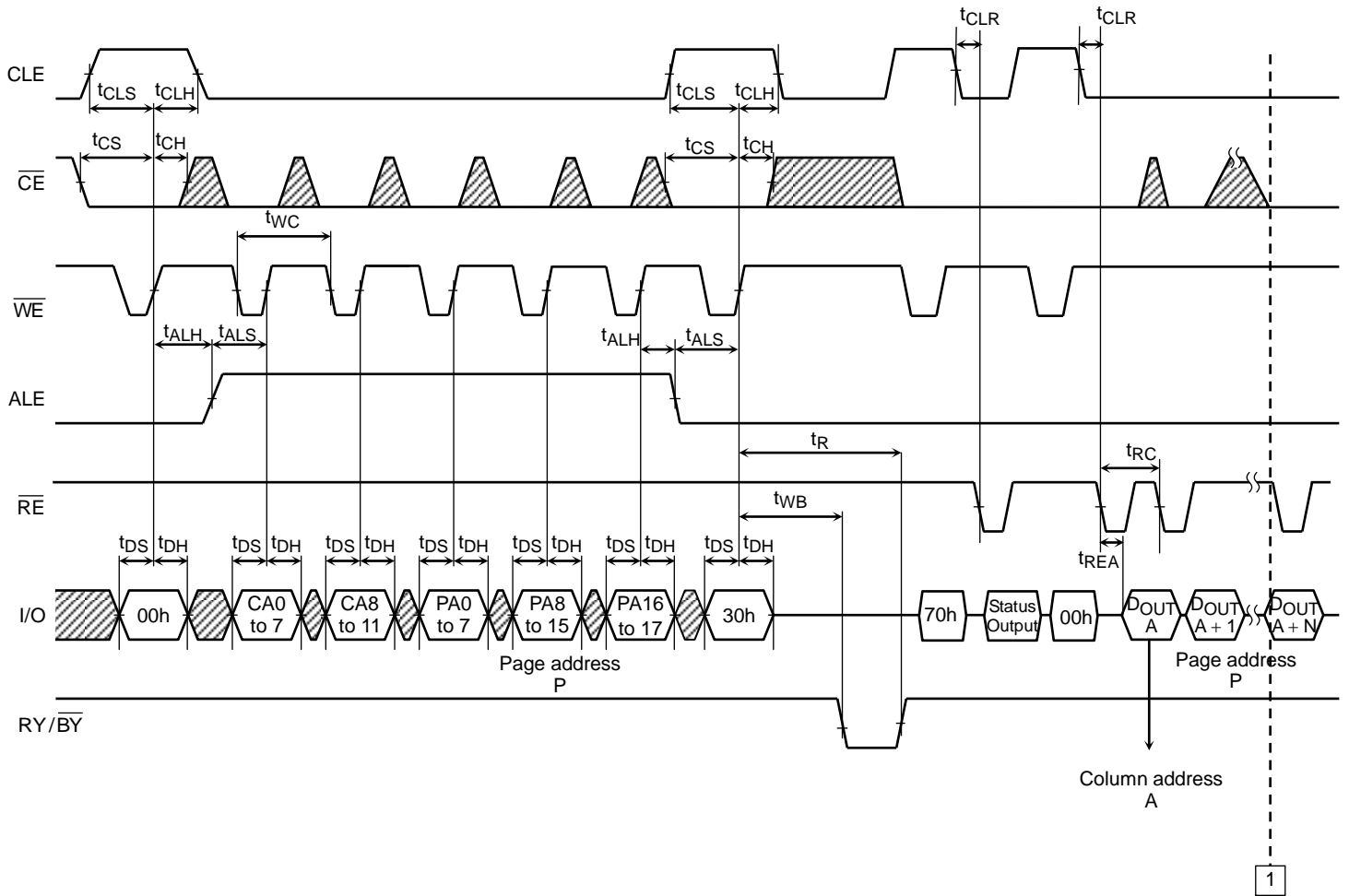

Continues to 1 of next page

Column Address Change in Read Cycle Timing Diagram (2/2)

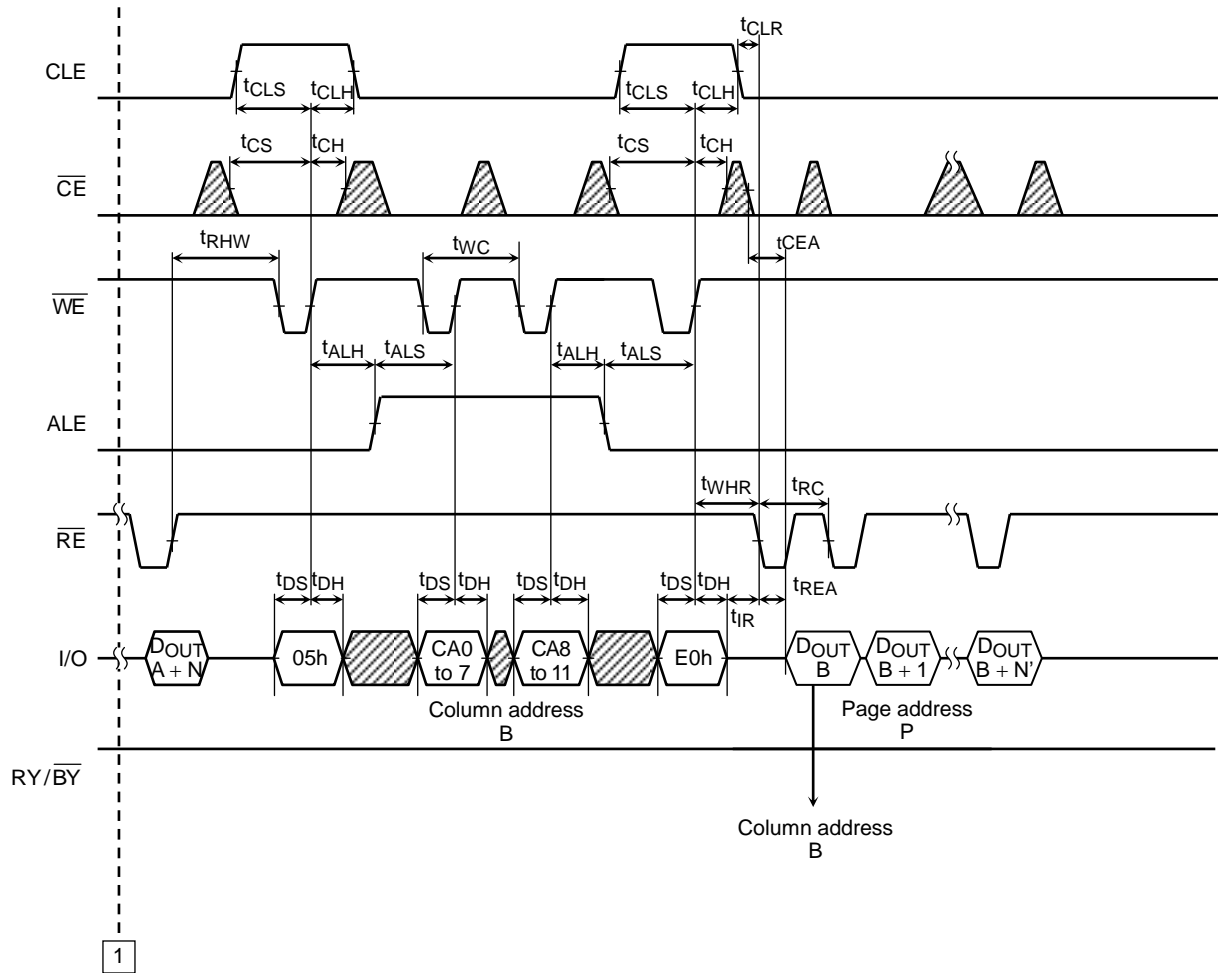

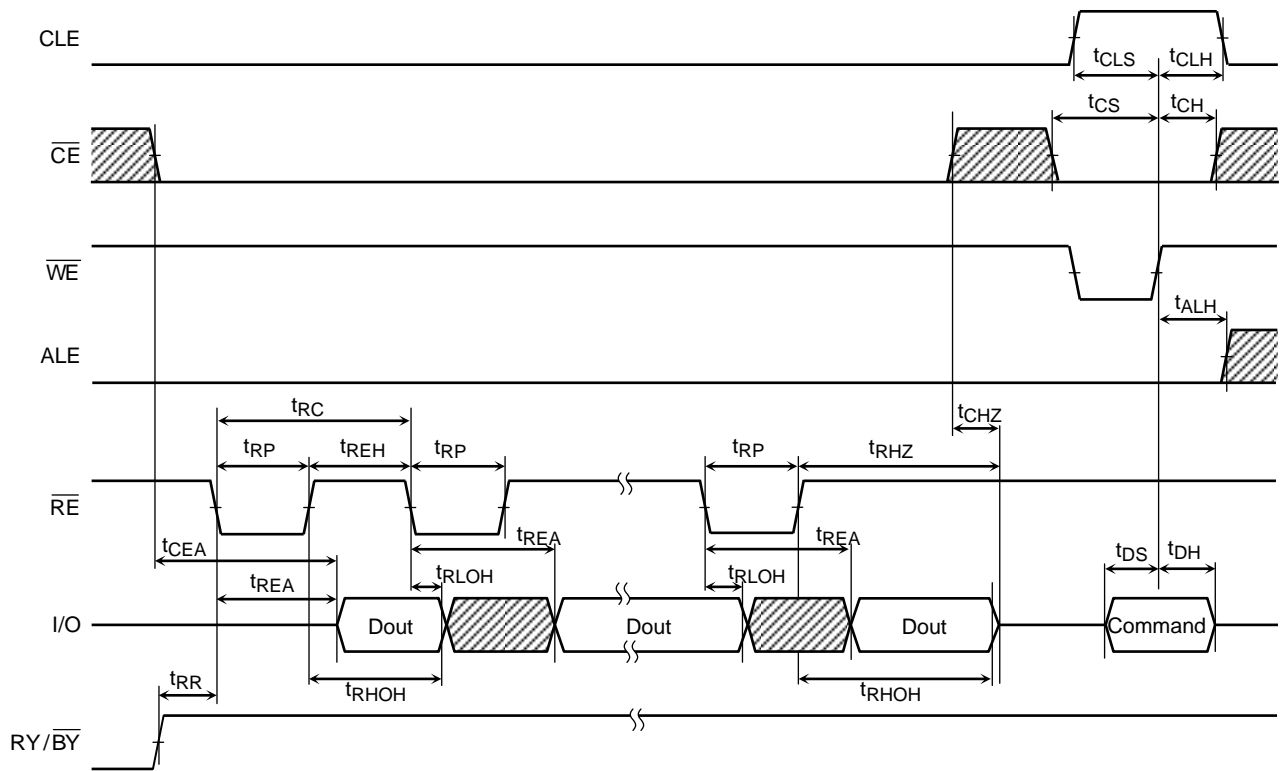

Continues from 1 of previous page

Data Output Timing Diagram

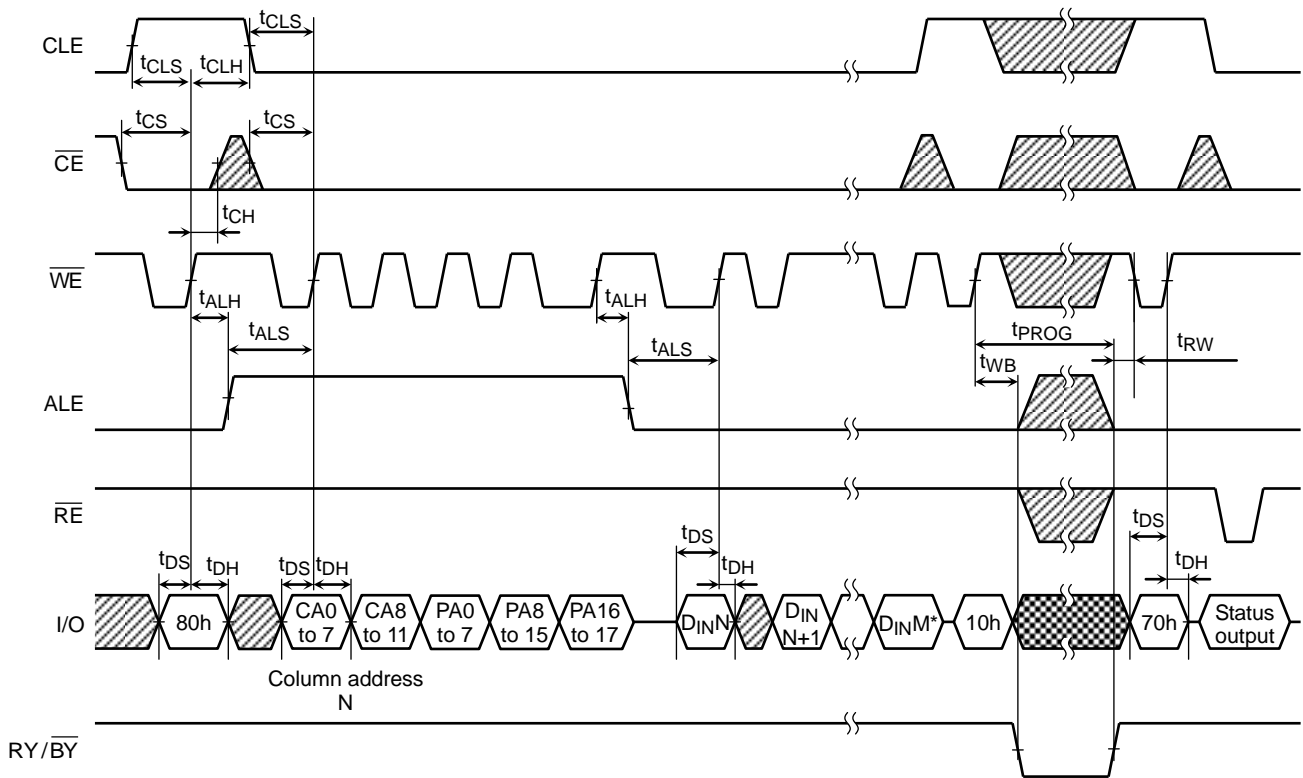

Auto-Program Operation Timing Diagram



 : Do not input data while data is being output.

 : V_{IH} or V_{IL}

*) M: up to 2111

Multi-Page Program Operation Timing Diagram (1/2)

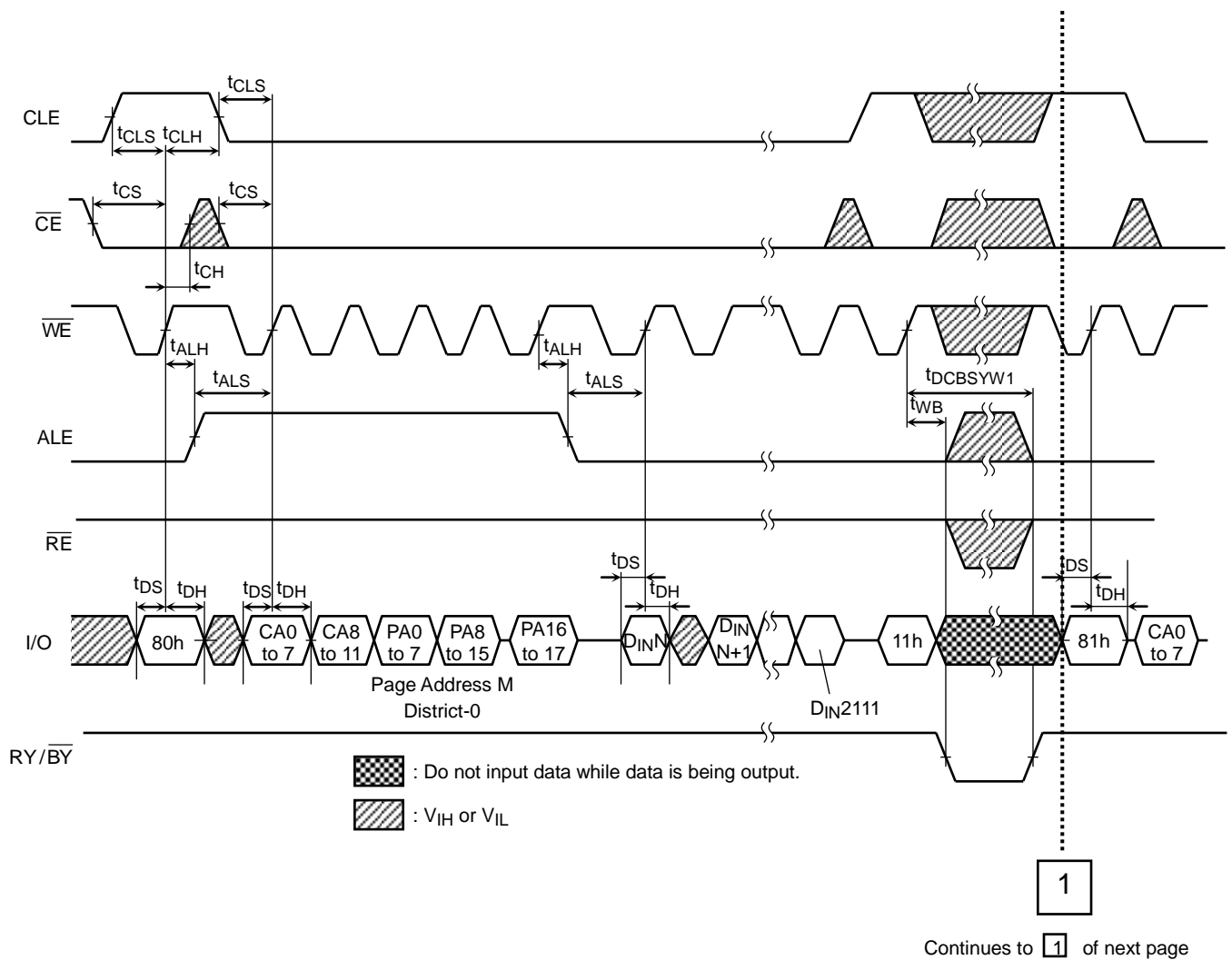

Multi-Page Program Operation Timing Diagram (2/2)

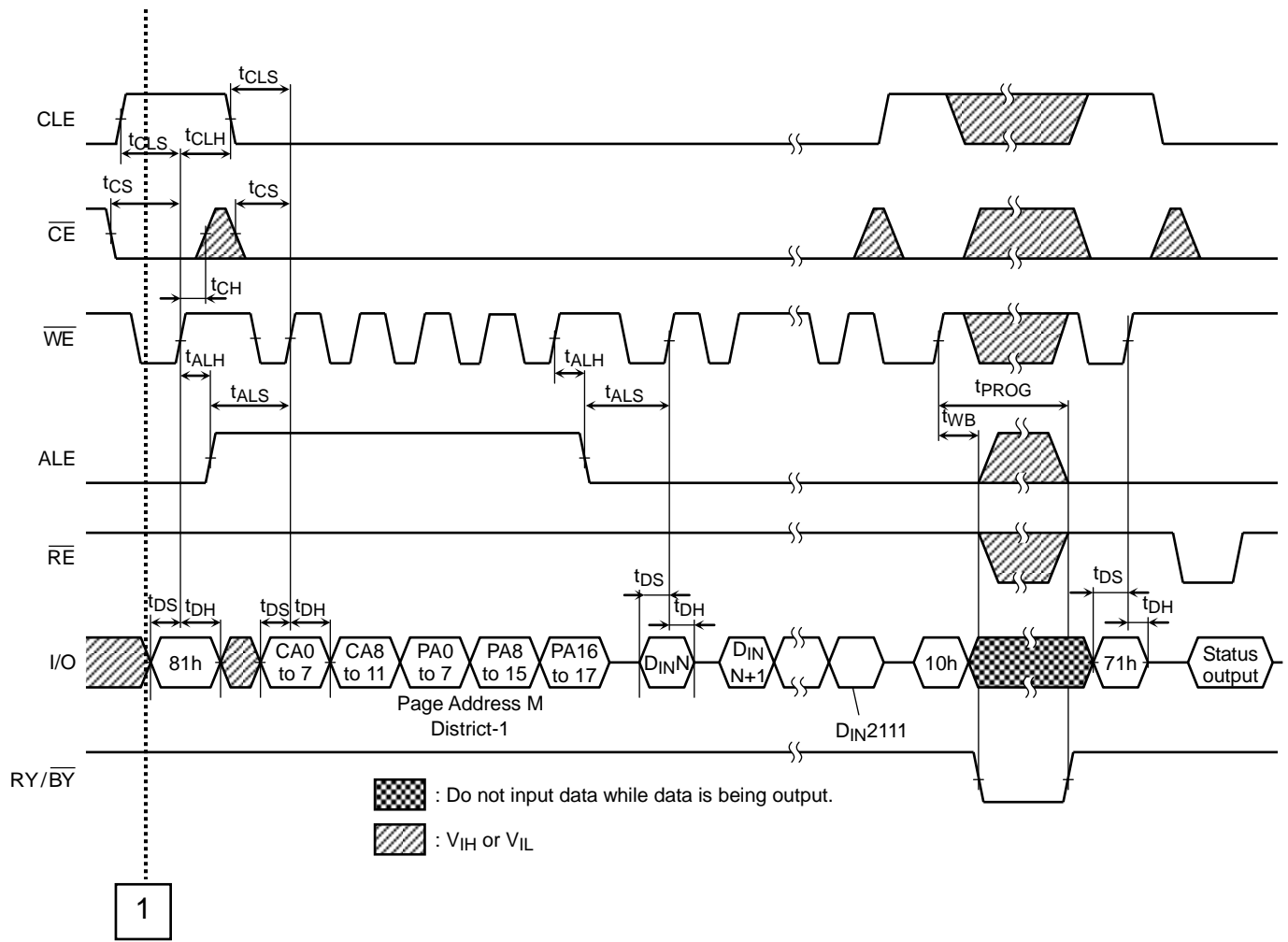

Continues from **1** of previous page

Auto Block Erase Timing Diagram

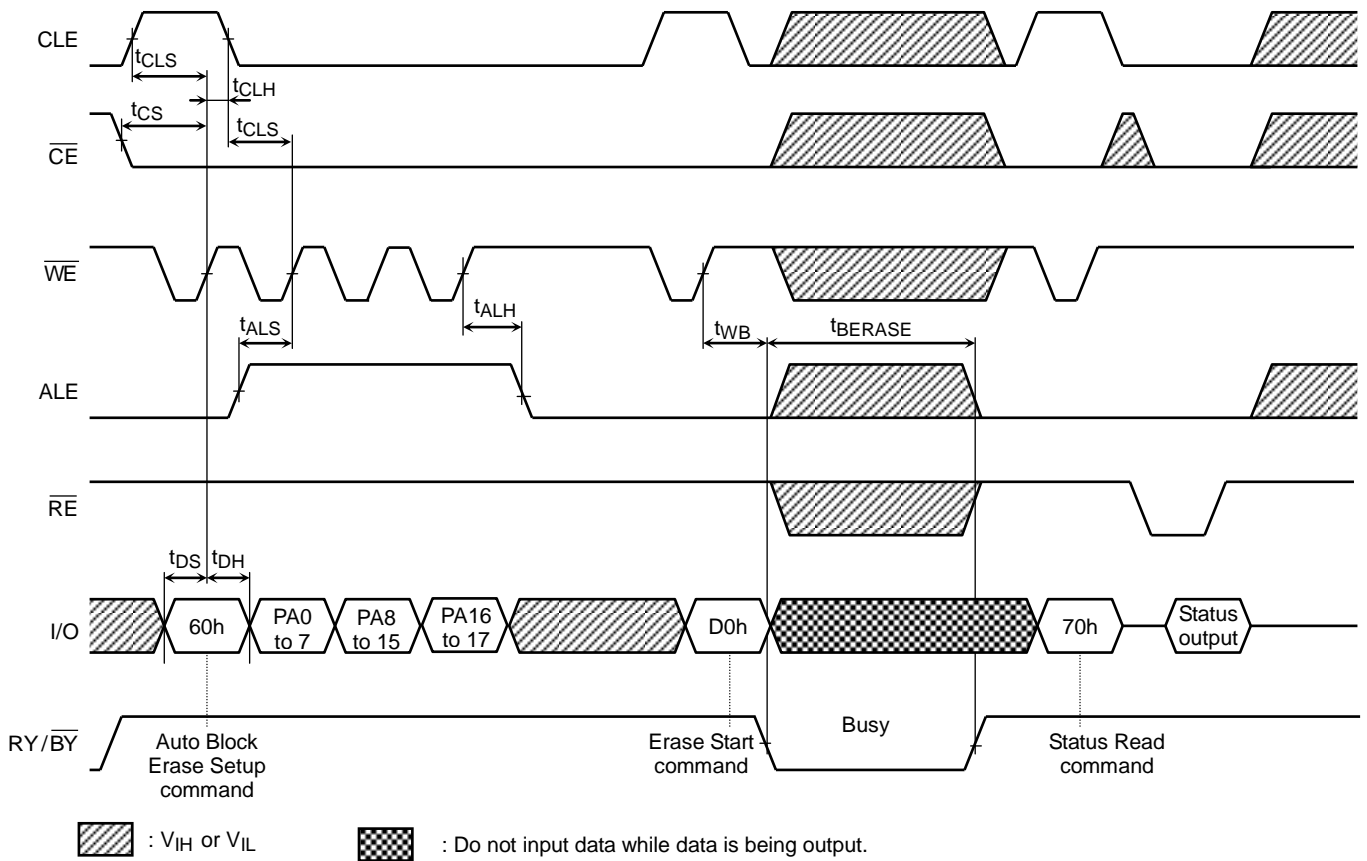

Multi Block Erase Timing Diagram

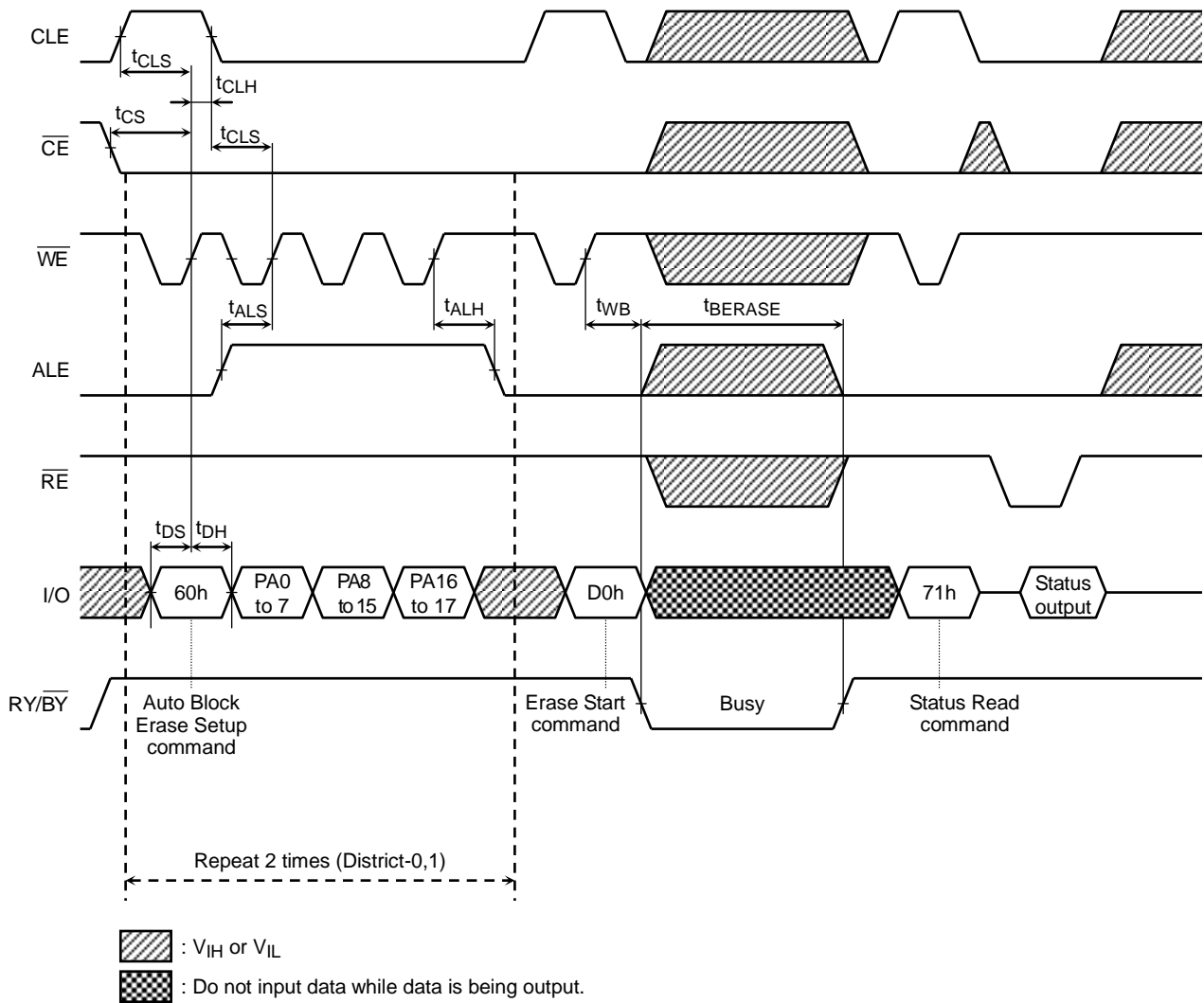

Copy Back Program with Random Data Input

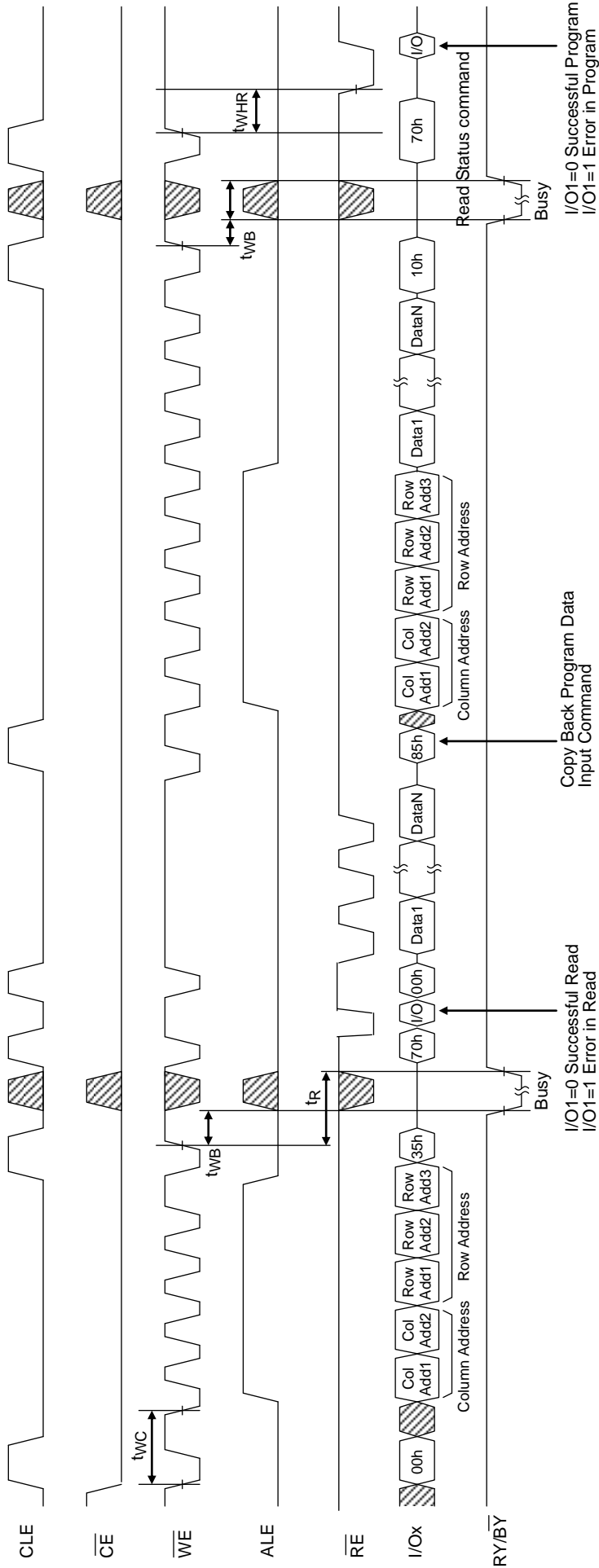

ID Read Operation Timing Diagram

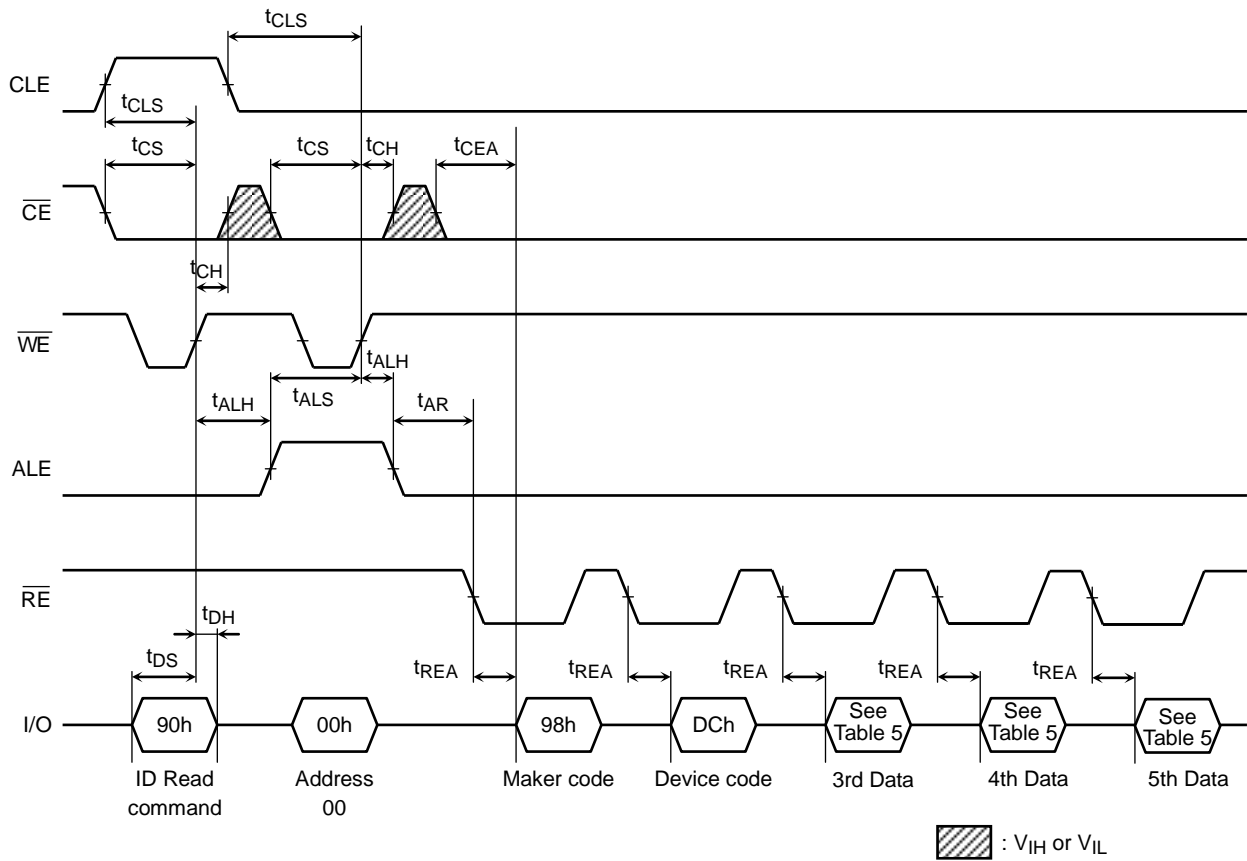

PIN FUNCTIONS

The device is a serial access memory which utilizes time-sharing input of address information.

Command Latch Enable: CLE

The CLE input signal is used to control loading of the operation mode command into the internal command register. The command is latched into the command register from the I/O port on the rising edge of the \overline{WE} signal while CLE is High.

Address Latch Enable: ALE

The ALE signal is used to control loading address information into the internal address register. Address information is latched into the address register from the I/O port on the rising edge of \overline{WE} while ALE is High.

Chip Enable: \overline{CE}

The device goes into a low-power Standby mode when \overline{CE} goes High during the device is in Ready state. The \overline{CE} signal is ignored when device is in Busy state ($RY/\overline{BY} = L$), such as during a Program or Erase or Read operation, and will not enter Standby mode even if the \overline{CE} input goes High.

Write Enable: \overline{WE}

The \overline{WE} signal is used to control the acquisition of data from the I/O port.

Read Enable: \overline{RE}

The \overline{RE} signal controls serial data output. Data is available t_{REA} after the falling edge of \overline{RE} . The internal column address counter is also incremented (Address = Address + 1) on this falling edge.

I/O Port: I/O1 to 8

The I/O1 to 8 pins are used as a port for transferring address, command and input/output data to and from the device.

Write Protect: \overline{WP}

The \overline{WP} signal is used to protect the device from accidental programming or erasing. The internal voltage regulator is reset when \overline{WP} is Low. This signal is usually used for protecting the data during the power-on/off sequence when input signals are invalid.

Ready/Busy: RY/\overline{BY}

The RY/\overline{BY} output signal is used to indicate the operating condition of the device. The RY/\overline{BY} signal is in Busy state ($RY/\overline{BY} = L$) during the Program, Erase and Read operations and will return to Ready state ($RY/\overline{BY} = H$) after completion of the operation. The output buffer for this signal is an open drain and has to be pulled-up to V_{ccq} with an appropriate resistor.

Schematic Cell Layout and Address Assignment

The Program operation works on page units while the Erase operation works on block units.

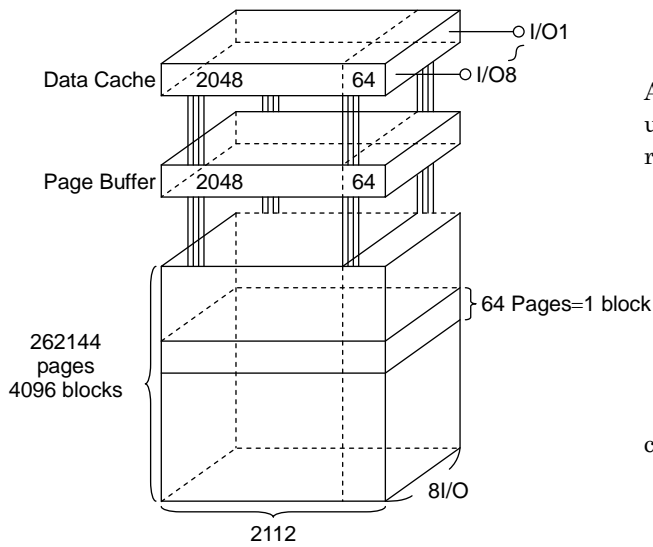

A page consists of 2112 bytes in which 2048 bytes are used for main memory storage and 64 bytes are for redundancy or for other uses.

$$1 \text{ page} = 2112 \text{ bytes}$$

$$1 \text{ block} = 2112 \text{ bytes} \times 64 \text{ pages} = (128\text{K} + 4\text{K}) \text{ bytes}$$

$$\text{Capacity} = 2112 \text{ bytes} \times 64 \text{ pages} \times 4096 \text{ blocks}$$

An address is read in via the I/O port over five consecutive clock cycles, as shown in Table 1.

Table 1. Addressing

	I/O8	I/O7	I/O6	I/O5	I/O4	I/O3	I/O2	I/O1
First cycle	CA7	CA6	CA5	CA4	CA3	CA2	CA1	CA0
Second cycle	L	L	L	L	CA11	CA10	CA9	CA8
Third cycle	PA7	PA6	PA5	PA4	PA3	PA2	PA1	PA0
Fourth cycle	PA15	PA14	PA13	PA12	PA11	PA10	PA9	PA8
Fifth cycle	L	L	L	L	L	L	PA17	PA16

CA0 to CA11: Column address

PA0 to PA17: Page address

PA6 to PA17: Block address

PA0 to PA5: NAND address in block

Operation Mode: Logic and Command Tables

The operation modes such as Program, Erase, Read and Reset are controlled by command operations shown in Table 3. Address input, command input and data input/output are controlled by the CLE, ALE, \overline{CE} , \overline{WE} , \overline{RE} and \overline{WP} signals, as shown in Table 2.

Table 2. Logic Table

	CLE	ALE	\overline{CE}	\overline{WE}	\overline{RE}	\overline{WP} *1
Command Input	H	L	L		H	*
Data Input	L	L	L		H	H
Address input	L	H	L		H	*
Serial Data Output	L	L	L	H		*
During Program (Busy)	*	*	*	*	*	H
During Erase (Busy)	*	*	*	*	*	H
During Read (Busy)	*	*	H	*	*	*
	*	*	L	H (*2)	H (*2)	*
Program, Erase Inhibit	*	*	*	*	*	L
Standby	*	*	H	*	*	0 V/V _{CC}

H: V_{IH}, L: V_{IL}, *: V_{IH} or V_{IL}

*1: Refer to Application Note (10) toward the end of this document regarding the \overline{WP} signal when Program or Erase Inhibit

*2: If \overline{CE} is low during read busy, \overline{WE} and \overline{RE} must be held High to avoid unintended command/address input to the device or read to device. Reset or Status Read command can be input during Read Busy.

DEVICE OPERATION

Read Mode

Read mode is set when the "00h" and "30h" commands are issued to the Command register. Between the two commands, a start address for the Read mode needs to be issued. After initial power on sequence, "00h" command is latched into the internal command register. Therefore read operation after power on sequence is executed by the setting of only five address cycles and "30h" command. Refer to the figures below for the sequence and the block diagram (Refer to the detailed timing chart.).

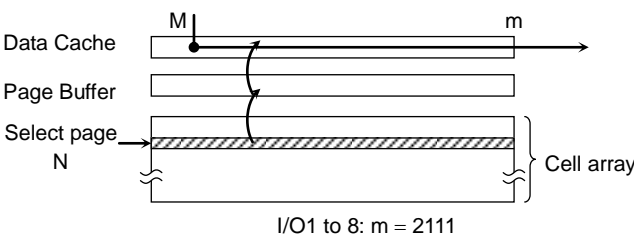
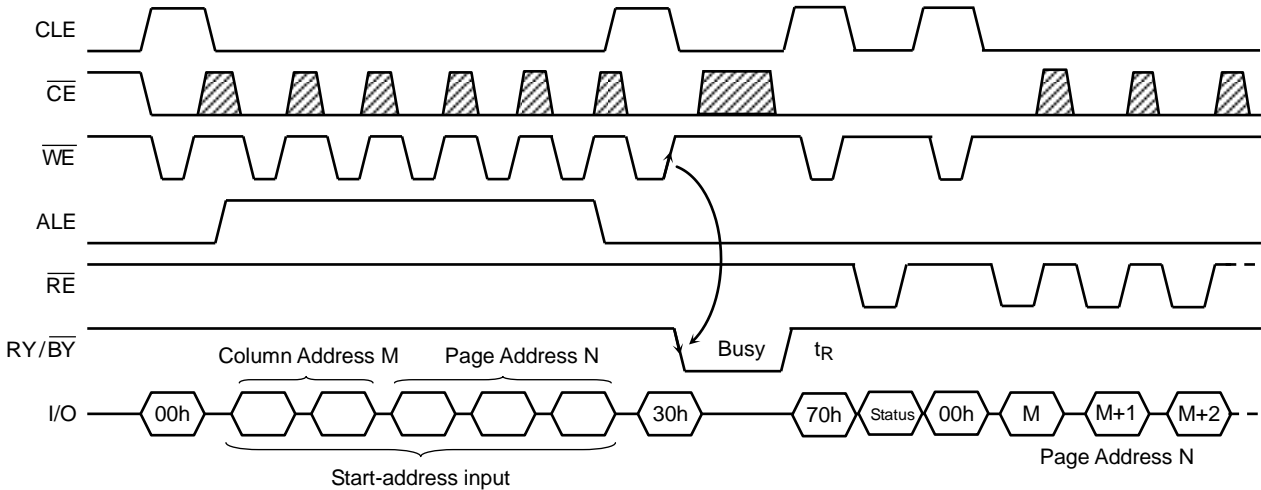

A data transfer operation from the cell array to the Data Cache via Page Buffer starts on the rising edge of \overline{WE} in the 30h command input cycle (after the address information has been latched). The device will be in the Busy state during this transfer period.

After the transfer period, the device returns to Ready state. Serial data can be output synchronously with the \overline{RE} clock from the start address designated in the address input cycle.

Random Column Address Change in Read Cycle

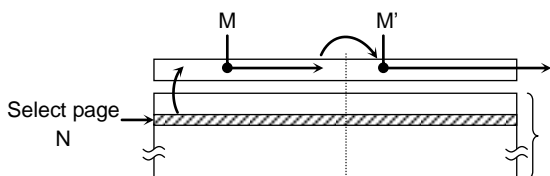
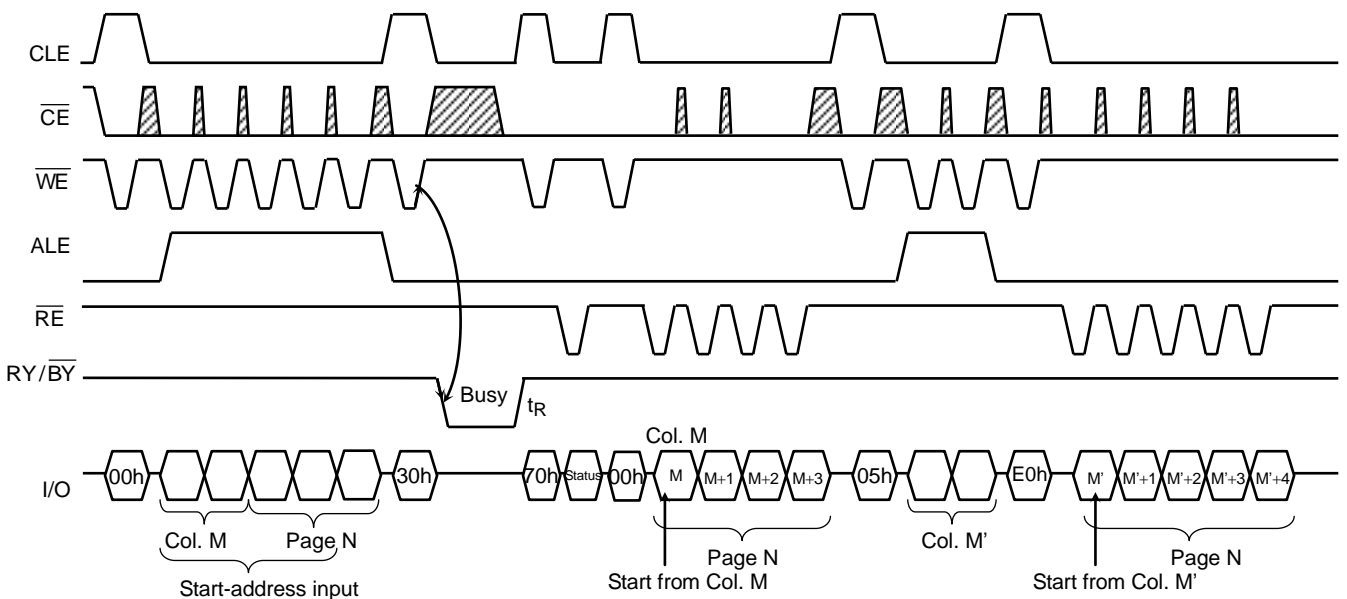

During the serial data output from the register, the column address can be changed by inputting a new column address using the 05h and E0h commands. The data is read out in serial starting at the new column address. Random Column Address Change operation can be done multiple times within the same page.

Multi Page Read Operation

The device has a Multi Page Read operation.
 The sequence of command and address input is shown below.
 Same page address (PA0 to PA5) within each district has to be selected.

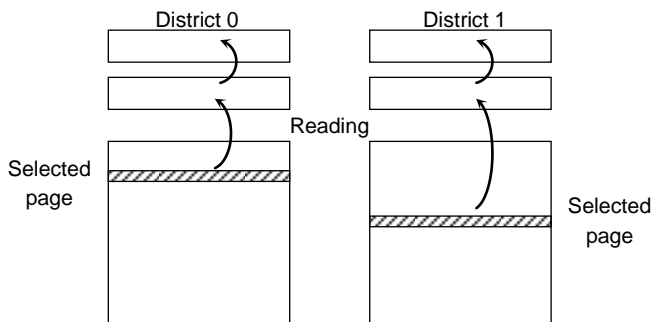
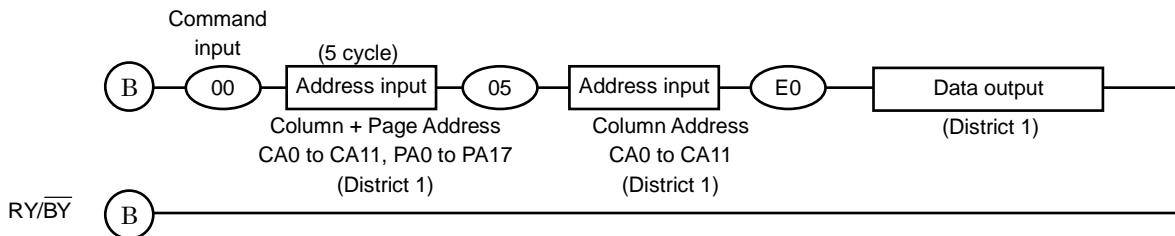
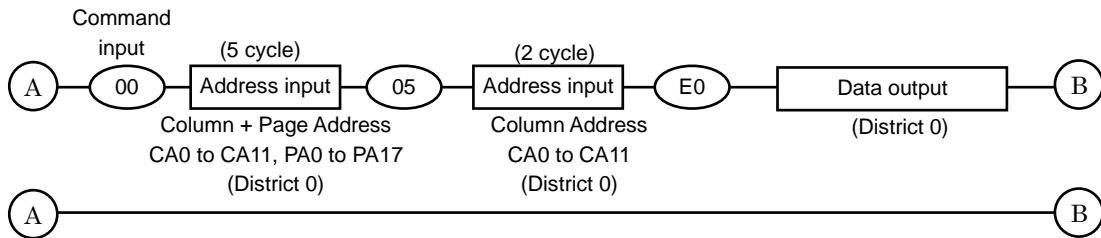
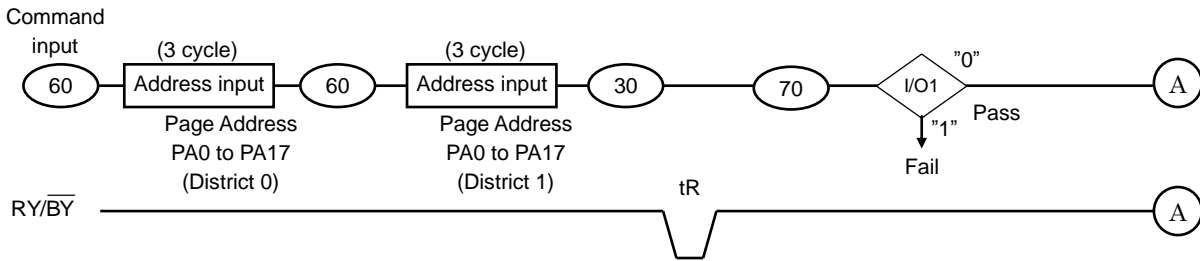

The data transfer operation from the cell array to the Data Cache via Page Buffer starts on the rising edge of \overline{WE} in the 30h command input cycle (after the 2 Districts address information has been latched). The device will be in the Busy state during this transfer period.

After the transfer period, the device returns to Ready state. Serial data can be output synchronously with the \overline{RE} clock from the start address designated in the address input cycle.

ECC Status command <7Ah> can be used only for Single Page Read. It is not supported for Multi Page Read operation.

Internal addressing in relation with the Districts

To use Multi Page Read operation, the internal addressing should be considered in relation with the District.

- The device consists from 2 Districts.
- Each District consists of 1024 erase blocks.
- The allocation rule is follows.
 - (a) District 0: Block 0, Block 2, Block 4, Block 6, ..., Block 2046
 - (b) District 1: Block 1, Block 3, Block 5, Block 7, ..., Block 2047
 - (c) District 0: Block 2048, Block 2050, Block 2052, ..., Block 4094
 - (d) District 1: Block 2049, Block 2051, Block 2053, ..., Block 4095

Combination of (a) and (b) or (c) and (d) can only be selected.

Address input restriction for the Multi Page Read operation

There are following restrictions in using Multi Page Read:

(Restriction)

Maximum one block should be selected from each District.

Same page address (PA0 to PA5) within two districts has to be selected.

For example:

(60) [District 0, Page Address 0x00000] (60) [District 1, Page Address 0x00040] (30)

(60) [District 0, Page Address 0x00001] (60) [District 1, Page Address 0x00041] (30)

(Acceptance)

There is no order limitation of the District for the address input.

For example, following operation is accepted;

(60) [District 0] (60) [District 1] (30)

(60) [District 1] (60) [District 0] (30)

It requires no mutual address relation between the selected blocks from each District.

Operating restriction during the Multi Page Read operation

Make sure \overline{WP} is held to High level when Multi Page Read operation is performed

ECC & Sector definition for ECC

Internal ECC logic generates Error Correction Code during busy time in program operation. The ECC logic manages 9bit error detection and 8bit error correction in each 528Bytes of main data and spare data. A section of main field (512Bytes) and spare field (16Bytes) are paired for ECC. During read, the device executes ECC of itself. Once read operation is executed, Read Status Command (70h) can be issued to check the read status. The read status remains until other valid commands are executed.

To use ECC function, below limitation must be considered.

- A sector is the minimum unit for program operation and the number of program per page must not exceed 4.

2KByte Page Assignment

1'st Main	2'nd Main	3'rd Main	4'th Main	1'st Spare	2'nd Spare	3'rd Spare	4'th Spare
512B	512B	512B	512B	16B	16B	16B	16B

Note) The Internal ECC manages all data of Main area and Spare area

Definition of 528Byte Sector

Sector	Column Address (Byte)	
	Main Field	Spare Field
1'st Sector	0 ~ 511	2,048 ~ 2,063
2'nd Sector	512 ~ 1,023	2,064 ~ 2,079
3'rd Sector	1,024 ~ 1,535	2,080 ~ 2,095
4'th Sector	1,536 ~ 2,047	2,096 ~ 2,111

Auto Page Program Operation

The device carries out an Automatic Page Program operation when it receives a "10h" Program command after the address and data have been input. The sequence of command, address and data input is shown below. (Refer to the detailed timing chart.)

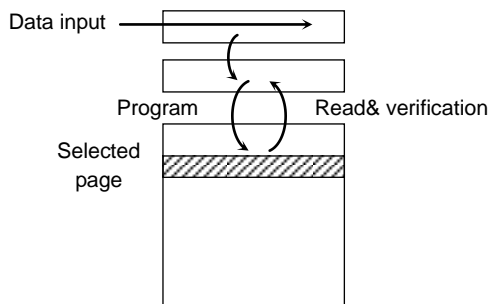
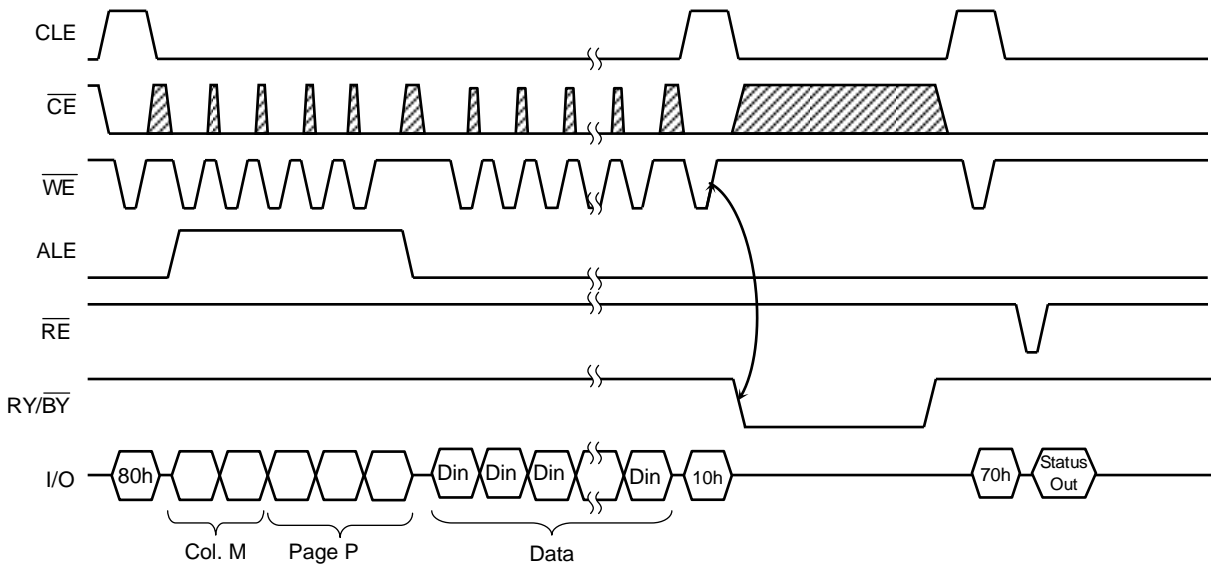

The data is transferred (programmed) from the Data Cache via the Page Buffer to the selected page on the rising edge of WE following input of the "10h" command. After programming, the programmed data is transferred back to the Page Buffer to be automatically verified by the device. If the programming does not succeed, the Program/Verify operation is repeated by the device until success is achieved or until the maximum loop number set in the device is reached.

Random Column Address Change in Auto Page Program Operation

The column address can be changed by the 85h command during the data input sequence of the Auto Page Program operation.

Two address input cycles after the 85h command are recognized as a new column address for the data input. After the new data is input to the new column address, the 10h command initiates the actual data program into the selected page automatically. The Random Column Address Change operation can be repeated multiple times within the same page.

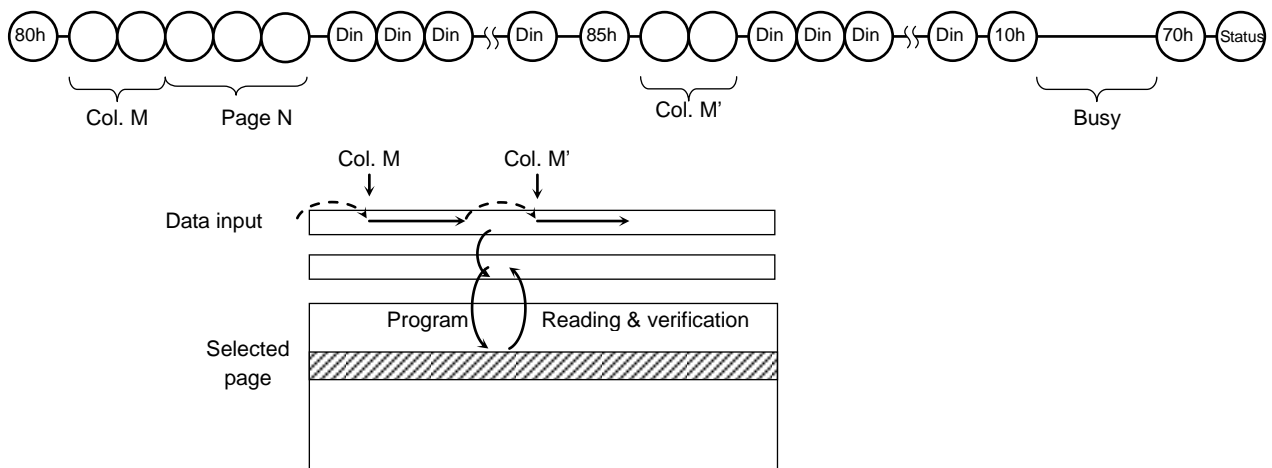

Multi Page Program

The device has a Multi Page Program, which enables even higher speed program operation compared to Auto Page Program. The sequence of command, address and data input is shown below. (Refer to the detailed timing chart.)

Although two planes are programmed simultaneously, pass/fail is not available for each page by “70h” command when the program operation completes. Status bit of I/O 1 is set to “1” when any of the pages fails. Limitation in addressing with Multi Page Program is shown below.

Multi Page Program

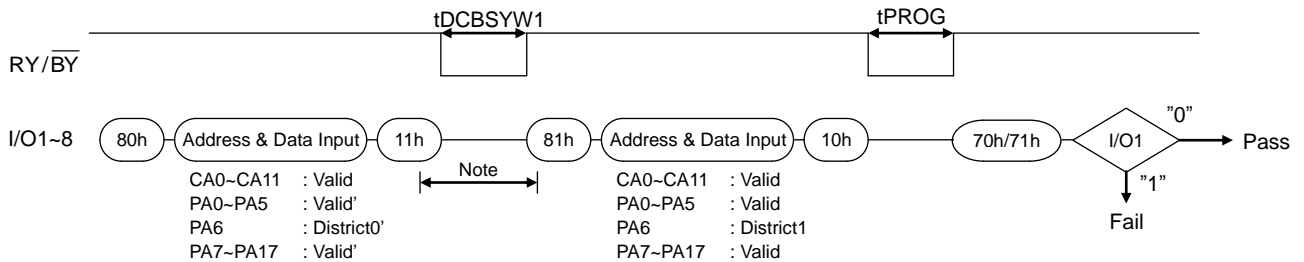

NOTE: Any command between 11h and 81h is prohibited except 70h and FFh.

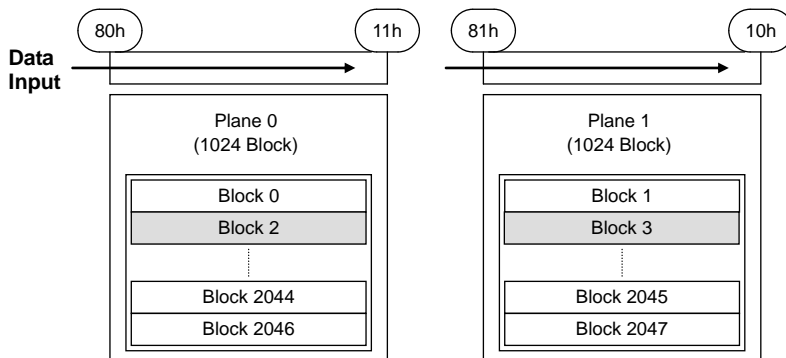

The 71h command Status description is as below.

	STATUS	OUTPUT	
I/O1	Chip Status : Pass/Fail	Pass: 0	Fail: 1
I/O2	District 0 Chip Status : Pass/Fail	Pass: 0	Fail: 1
I/O3	District 1 Chip Status : Pass/Fail	Pass: 0	Fail: 1
I/O4	Not Used	Invalid	
I/O5	Not Used	Invalid	
I/O6	Ready/Busy	Ready: 1	Busy: 0
I/O7	Ready/Busy	Ready: 1	Busy: 0
I/O8	Write Protect	Protect: 0	Not Protect: 1

I/O1 describes Pass/Fail condition of district 0 and 1(OR data of I/O2 and I/O3). If one of the districts fails during multi page program operation, it shows “Fail”.
I/O2 to 3 shows the Pass/Fail condition of each district..

Internal addressing in relation with the Districts

To use Multi Page Program operation, the internal addressing should be considered in relation with the District.

- The device consists of 2 Districts.
- Each District consists from 1024 erase blocks.
- The allocation rule is follows.
 - (a) District 0: Block 0, Block 2, Block 4, Block 6, ..., Block 2046
 - (b) District 1: Block 1, Block 3, Block 5, Block 7, ..., Block 2047
 - (c) District 0: Block 2048, Block 2050, Block 2052, ..., Block 4094
 - (d) District 1: Block 2049, Block 2051, Block 2053, ..., Block 4095

Combination of (a) and (b) or (c) and (d) can only be selected.

Address input restriction for the Multi Page Program operation

There are following restrictions in using Multi Page Program:

(Restriction)

Maximum one block should be selected from each District.

Same page address (PA0 to PA5) within two districts has to be selected.

For example:

(80) [District 0, Page Address 0x00000] (11) (81) [District 1, Page Address 0x00040] (10)
(80) [District 0, Page Address 0x00001] (11) (81) [District 1, Page Address 0x00041] (10)

(Acceptance)

There is no order limitation of the District for the address input.

For example, following operation is accepted;

(80) [District 0] (11) (81) [District 1] (10)
(80) [District 1] (11) (81) [District 0] (10)

It requires no mutual address relation between the selected blocks from each District.

Operating restriction during the Multi Page Program operation

(Restriction)

The operation has to be terminated with "10h" command.

Once the operation is started, no commands other than the commands shown in the timing diagram is allowed to be input except for Status Read command and reset command.

Auto Block Erase

The Auto Block Erase operation starts on the rising edge of \overline{WE} after the Erase Start command “D0h” which follows the Erase Setup command “60h”. This two-cycle process for Erase operations acts as an extra layer of protection from accidental erasure of data due to external noise. The device automatically executes the Erase and Verify operations.

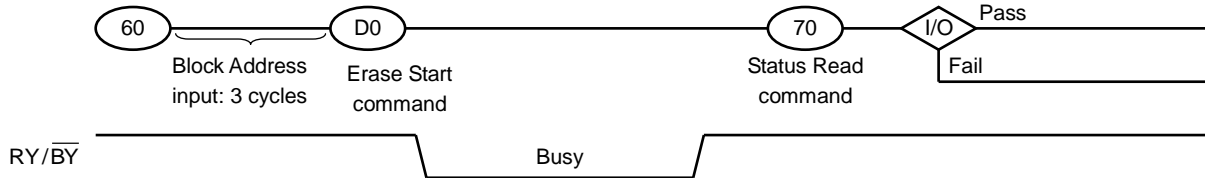

Multi Block Erase

The Multi Block Erase operation starts by selecting two block addresses before D0h command as in below diagram. The device automatically executes the Erase and Verify operations and the result can be monitored by checking the status by 71h status read command. For details on 71h status read command, refer to section “Multi Page Program”.

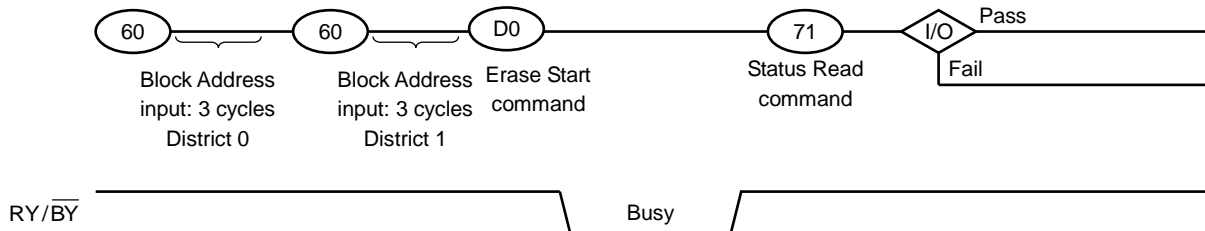

Internal addressing in relation with the Districts

To use Multi Block Erase operation, the internal addressing should be considered in relation with the District.

- The device consists from 2 Districts.
- Each District consists from 1024 erase blocks.
- The allocation rule is follows.
 - (a) District 0: Block 0, Block 2, Block 4, Block 6, ..., Block 2046
 - (b) District 1: Block 1, Block 3, Block 5, Block 7, ..., Block 2047
 - (c) District 0: Block 2048, Block 2050, Block 2052, ..., Block 4094
 - (d) District 1: Block 2049, Block 2051, Block 2053, ..., Block 4095

Combination of (a) and (b) or (c) and (d) can only be selected.

Address input restriction for the Multi Block Erase

There are following restrictions in using Multi Block Erase.

(Restriction)

Maximum one block should be selected from each District.

For example;

(60) [District 0] (60) [District 1] (D0)

(Acceptance)

There is no order limitation of the District for the address input.

For example, following operation is accepted;

(60) [District 1] (60) [District 0] (D0)

It requires no mutual address relation between the selected blocks from each District.

Make sure to terminate the operation with D0h command. If the operation needs to be terminated before D0h command input, input the FFh reset command to terminate the operation.

READ FOR COPY-BACK WITH DATA OUTPUT TIMING GUIDE

Copy-Back operation is a sequence execution of Read for Copy-Back and of copy-back program with the destination page address. A read operation with “35h” command and the address of source page moves the whole 2112 bytes data into the internal data buffer. Bit errors are checked by sequential reading the data or by reading the status in read after read busy time(t_R) to check if uncorrectable error occurs. In the case where there is no bit error or no uncorrectable error, the data don't need to be reloaded. Therefore Copy-Back program operation is initiated by issuing Page-Copy Data-Input command (85h) with destination page address. Actual programming operation begins after Program Confirm command (10h) is issued. Once the program process starts, the Read Status Register command (70h) may be entered to read the status register. The system controller can detect the completion of a program cycle by monitoring the RY/BY output, or the Status Bit (I/O7) of the Status Register. When the Copy-Back Program is complete, the Write Status Bit (I/O1) may be checked. The command register remains in Read Status command mode until another valid command is written to the command register. During copy-Back program, data modification is possible using random data input command (85h) as shown below.

Page Copy-Back Program Operation

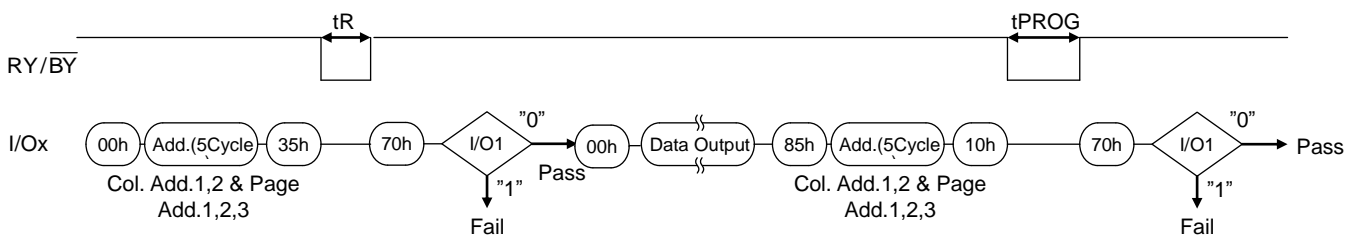

NOTE: 1. Copy-Back Program operation is allowed only within the same district.

Page Copy-Back Program Operation with Random Data Input

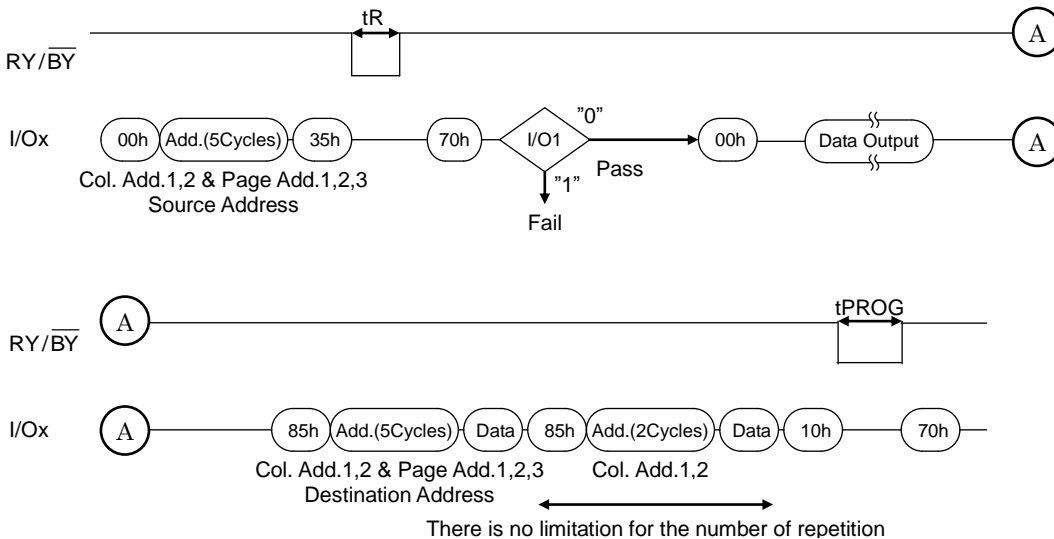

ID Read

The device contains ID codes which can be used to identify the device type, the manufacturer, and features of the device. The ID codes can be read out under the following timing conditions:

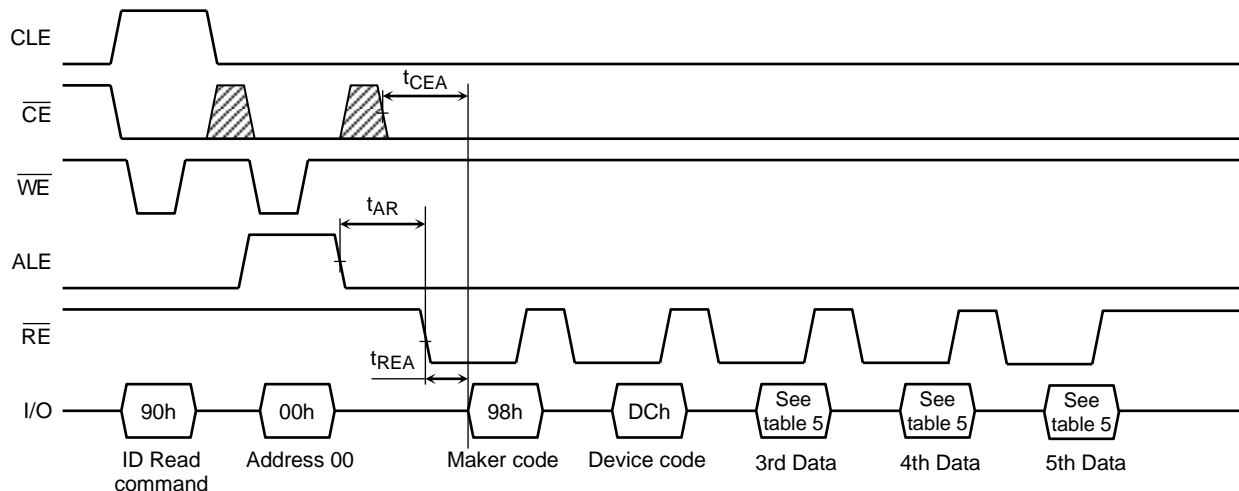

Table 5. Code table

	Description	I/O8	I/O7	I/O6	I/O5	I/O4	I/O3	I/O2	I/O1	Hex Data
1st Data	Maker Code	1	0	0	1	1	0	0	0	98h
2nd Data	Device Code	1	1	0	1	1	1	0	0	DCh
3rd Data	Chip Number, Cell Type	1	0	0	1	0	0	0	1	91h
4th Data	Page Size, Block Size	0	0	0	1	0	1	0	1	15h
5th Data	Plane Number	1	1	1	1	0	1	1	0	F6h

3rd Data

	Description	I/O8	I/O7	I/O6	I/O5	I/O4	I/O3	I/O2	I/O1
Internal Chip Number	1							0	0
	2							0	1
	4							1	0
	8							1	1
Cell Type	2 level cell					0	0		
	4 level cell					0	1		
	8 level cell					1	0		
	16 level cell					1	1		
Reserved		1	0	0	1				

4th Data

	Description	I/O8	I/O7	I/O6	I/O5	I/O4	I/O3	I/O2	I/O1
Page Size (without redundant area)	1 KB							0	0
	2 KB							0	1
	4 KB							1	0
	8 KB							1	1
Block Size (without redundant area)	64 KB			0	0				
	128 KB			0	1				
	256 KB			1	0				
	512 KB			1	1				
I/O Width	x8		0						
	x16		1						
Reserved		0				0	1		

5th Data

	Description	I/O8	I/O7	I/O6	I/O5	I/O4	I/O3	I/O2	I/O1
Plane Number	1 Plane					0	0		
	2 Plane					0	1		
	4 Plane					1	0		
	8 Plane					1	1		
ECC engine on chip	With ECC engine	1							
Reserved			1	1	1			1	0

Status Read

The device automatically implements the execution and verification of the Program and Erase operations. The Status Read function is used to monitor the Ready/Busy status of the device, determine the result (pass/fail) of a Program or Erase operation, and determine whether the device is in Protect mode. The device status is output via the I/O port using \overline{RE} after a “70h” command input. The Status Read can also be used during a Read operation to find out the Ready/Busy status.

The resulting information is outlined in Table 6.

Table 6. Status output table

	Definition	Page Program	Block Erase	Read
I/O1	Chip Status Pass: 0 Fail: 1	Pass/Fail	Pass/Fail	Pass/Fail(Uncorrectable)
I/O2	Not Used	Invalid	Invalid	Invalid
I/O3	Not Used	0	0	0
I/O4	Chip Read Status Normal or uncorrectable: 0 Recommended to rewrite : 1	0	0	Normal or uncorrectable / Recommended to rewrite
I/O5	Not Used	0	0	0
I/O6	Ready/Busy Ready: 1 Busy: 0	Ready/Busy	Ready/Busy	Ready/Busy
I/O7	Ready/Busy Ready: 1 Busy: 0	Ready/Busy	Ready/Busy	Ready/Busy
I/O8	Write Protect Not Protected :1 Protected: 0	Write Protect	Write Protect	Write Protect

The Pass/Fail status on I/O1 is only valid during a Program/Erase operation when the device is in the Ready state.

ECC Status Read

The ECC Status Read function is used to monitor the Error Correction Status. 24nm BENAND can correct up to 8bit errors.

ECC can be performed on the NAND Flash main and spare areas. The ECC Status Read function can also show the number of errors in a sector as a result of an ECC check in during a read operation.

8	7	6	5	4	3	2	I/O1
Sector Information				ECC Status			

ECC Status

I/O4 to I/O1	ECC Status
0000	No Error
0001	1bit error(Correctable)
0010	2bit error(Correctable)
0011	3bit error(Correctable)
0100	4bit error(Correctable)
0101	5bit error(Correctable)
0110	6bit error(Correctable)
0111	7bit error(Correctable)
1000	8bit error(Correctable)
1111	Uncorrectable Error

Sector Information

I/O8 to I/O5	Sector Information
0000	1st Sector (Main and Spare area)
0001	2nd Sector (Main and Spare area)
0010	3rd Sector (Main and Spare area)
0011	4th Sector (Main and Spare area)
Other	Reserved

Reset

The Reset mode stops all operations. For example, in case of a Program or Erase operation, the internally generated voltage is discharged to 0 volt and the device enters the Wait state.

Reset during a Page Copy may not just stop the most recent page program but it may also stop the previous program to a page depending on when the FF reset is input.

The response to a “FFh” Reset command input during the various device operations is as follows:

When a Reset (FFh) command is input during programming

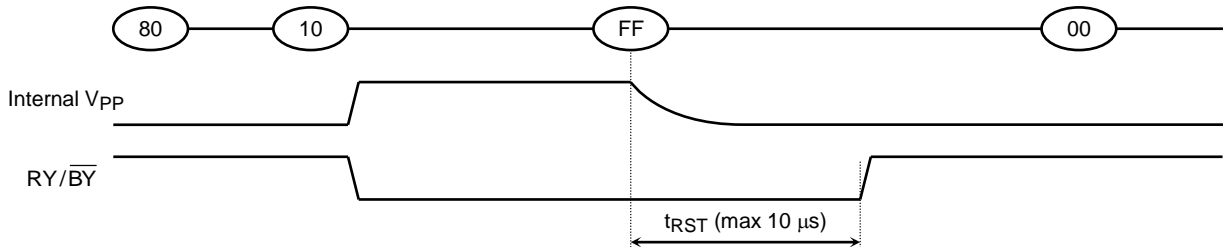

When a Reset (FFh) command is input during erasing

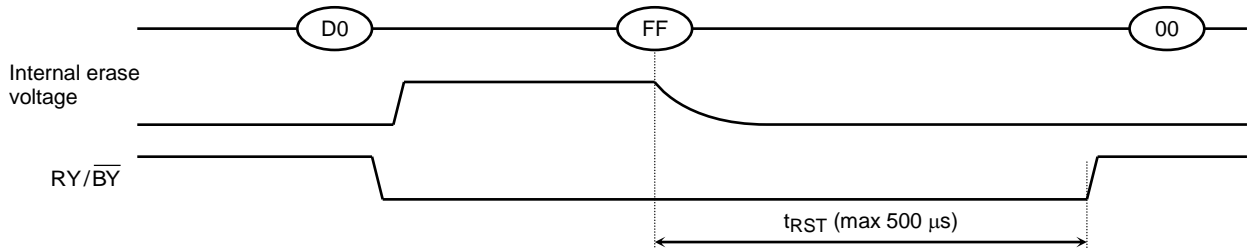

When a Reset (FFh) command is input during Read operation

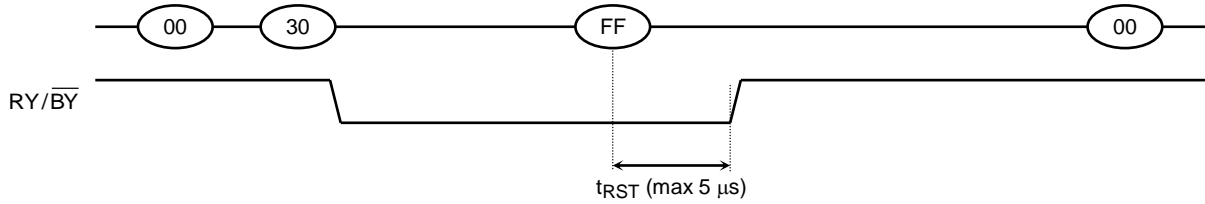

When a Reset (FFh) command is input during Ready

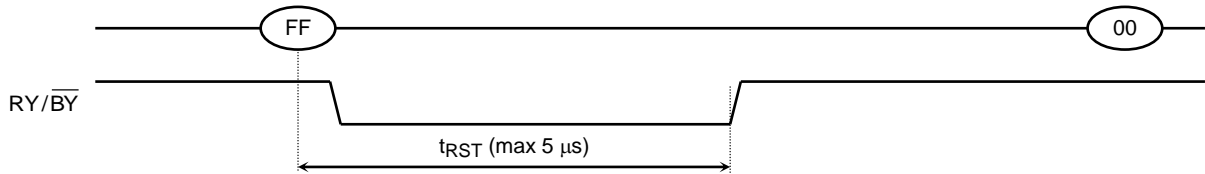

When a Status Read command (70h) is input after a Reset

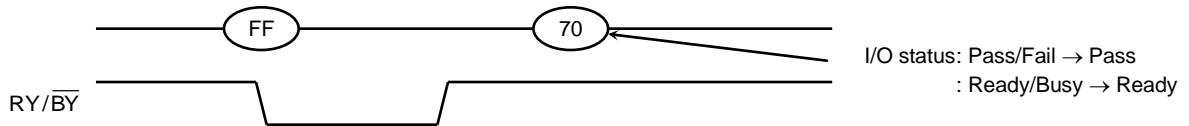

When two or more Reset commands are input in succession

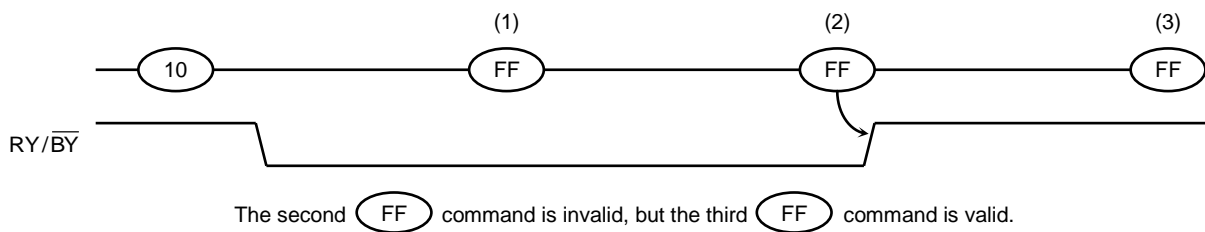

APPLICATION NOTES AND COMMENTS

(1) Power-on/off sequence:

The timing sequence shown in the figure below is necessary for the power-on/off sequence.

The device internal initialization starts after the power supply reaches an appropriate level in the power on sequence. During the initialization the device Ready/Busy signal indicates the Busy state as shown in the figure below. In this time period, the acceptable commands are FFh or 70h.

The \overline{WP} signal is useful for protecting against data corruption at power-on/off.

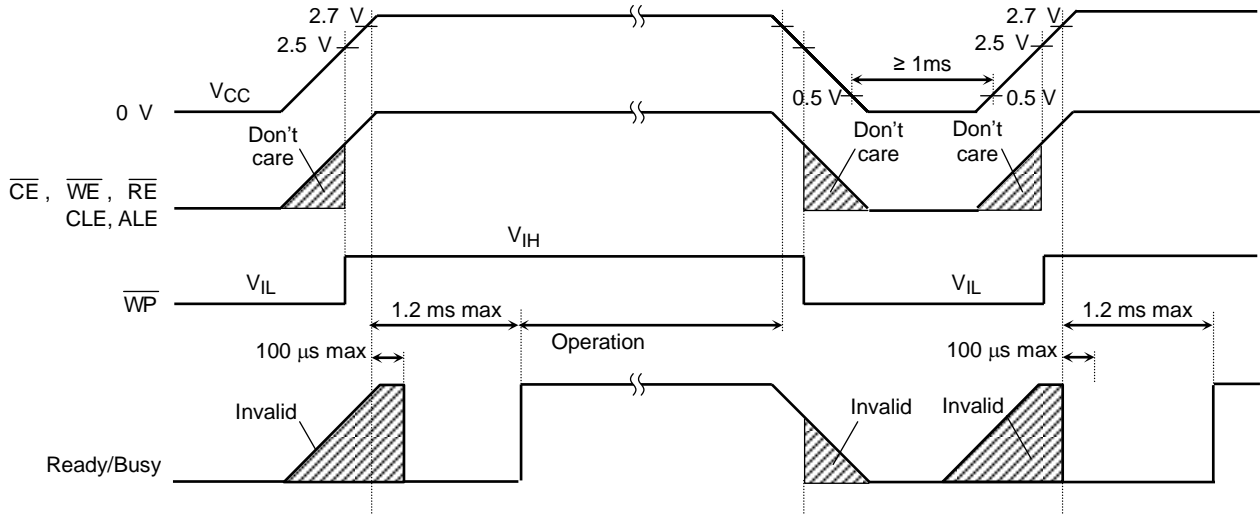

(2) Power-on Reset

The following sequence is necessary because some input signals may not be stable at power-on.

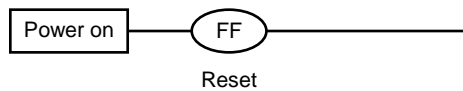

(3) Prohibition of unspecified commands

The operation commands are listed in Table 3. Input of a command other than those specified in Table 3 is prohibited. Stored data may be corrupted if an unknown command is entered during the command cycle.

(4) Restriction of commands while in the Busy state

During the Busy state, do not input any command except 70h,71h and FFh.

(5) Acceptable commands after Serial Input command “80h”

Once the Serial Input command “80h” has been input, do not input any command other than the Column Address Change in Serial Data Input command “85h”, Auto Program command “10h”, Multi Page Program command “11h” or the Reset command “FFh”.

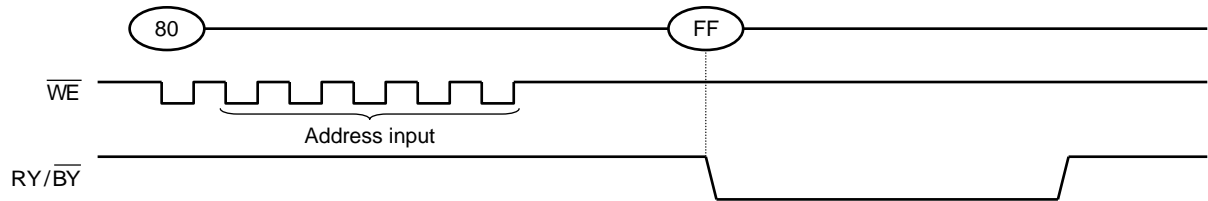

If a command other than “85h”, “10h”, “11h” or “FFh” is input, the Program operation is not performed and the device operation is set to the mode which the input command specifies.

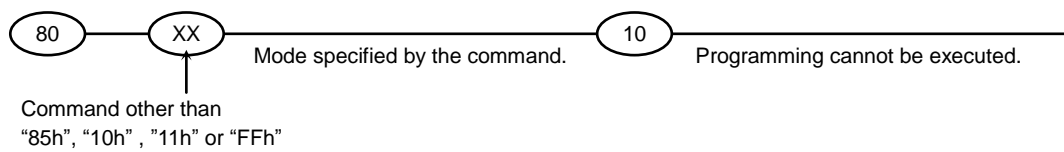

(6) Addressing for program operation

Within a block, the pages must be programmed consecutively from the LSB (least significant bit) page of the block to MSB (most significant bit) page of the block. Random page address programming is prohibited.

From the LSB page to MSB page

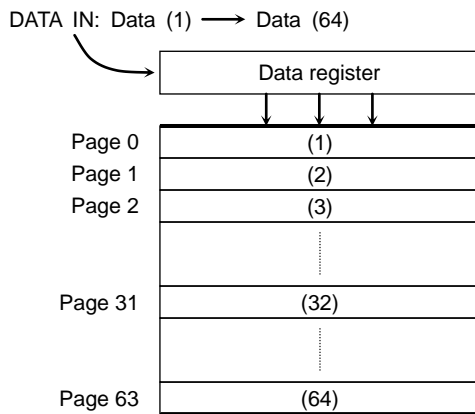

Ex.) Random page program (Prohibition)

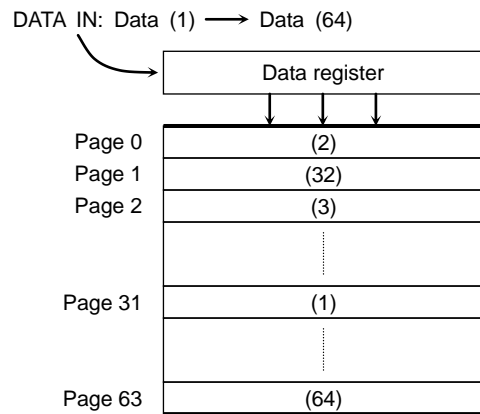

(7) Status Read during a Read operation

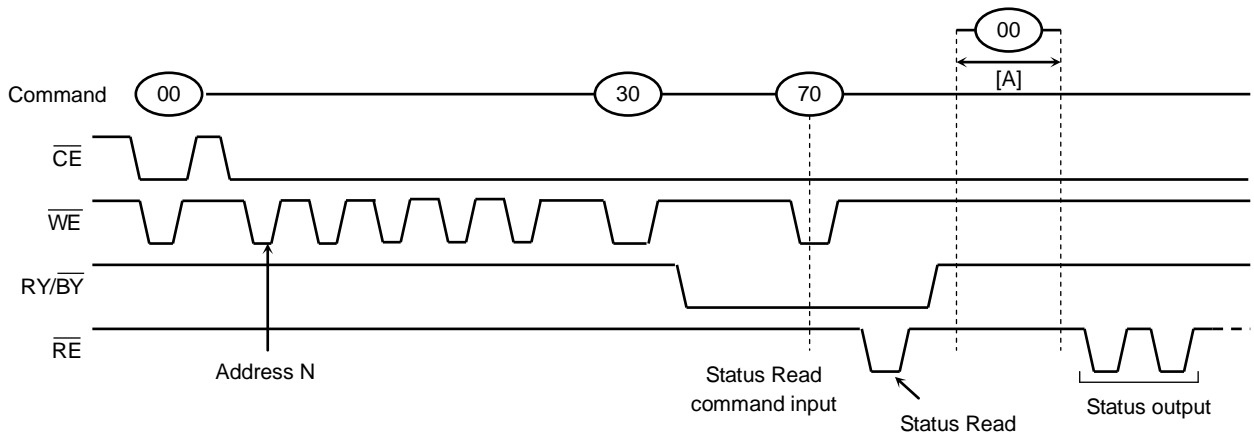

The device status can be read out by inputting the Status Read command “70h” in Read mode. Once the device has been set to Status Read mode by a “70h” command, the device will not return to Read mode unless the Read command “00h” is inputted during [A]. If the Read command “00h” is inputted during [A], Status Read mode is reset, and the device returns to Read mode. In this case, data output starts automatically from address N and address input is unnecessary

(8) Auto programming failure

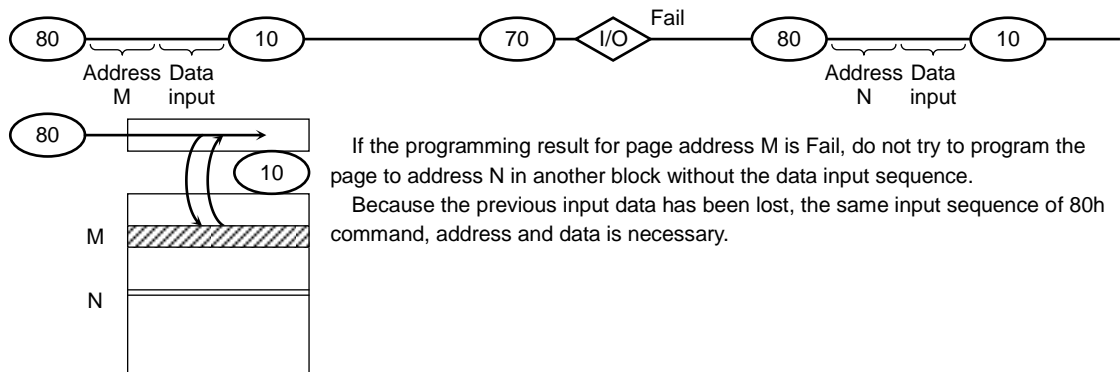

(9) RY / BY : termination for the Ready/Busy pin (RY / BY)

A pull-up resistor needs to be used for termination because the RY / BY buffer consists of an open drain circuit.

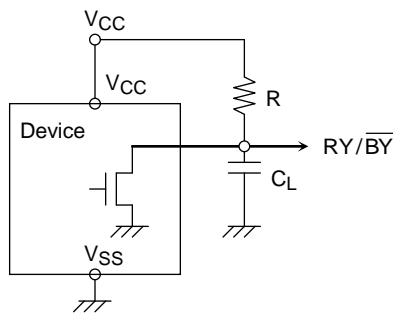

This data may vary from device to device. We recommend that you use this data as a reference when selecting a resistor value.

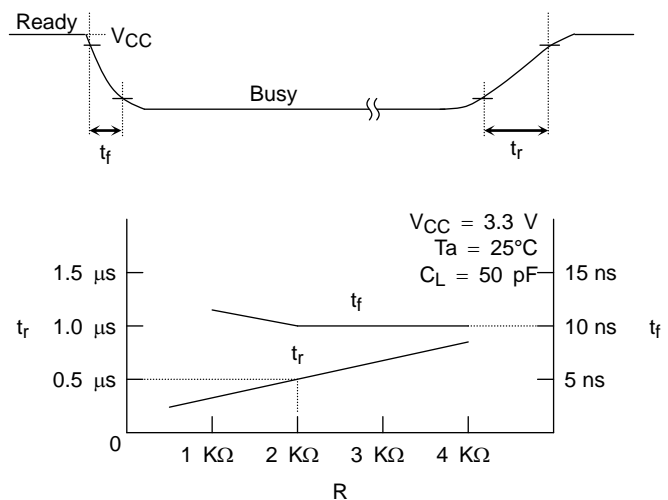

(10) Note regarding the \overline{WP} signal

The Erase and Program operations are automatically reset when \overline{WP} goes Low. The operations are enabled and disabled as follows:

Enable Programming

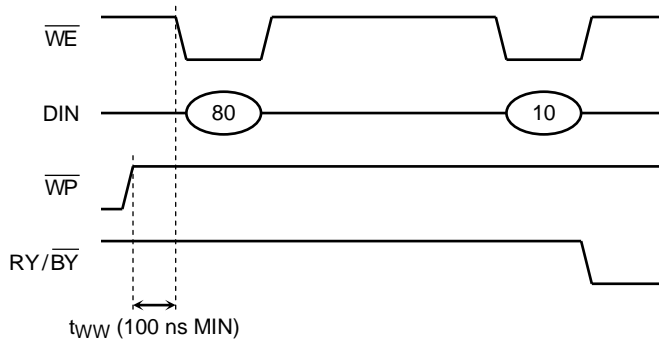

Disable Programming

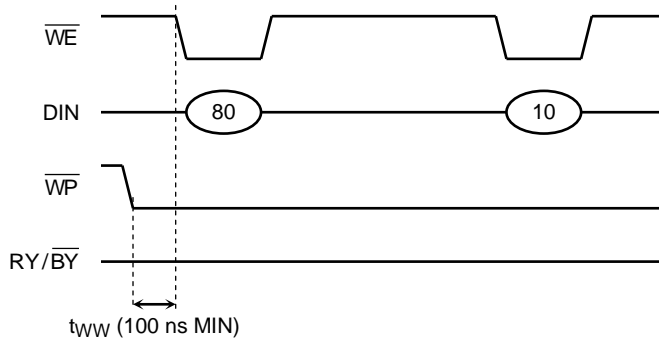

Enable Erasing

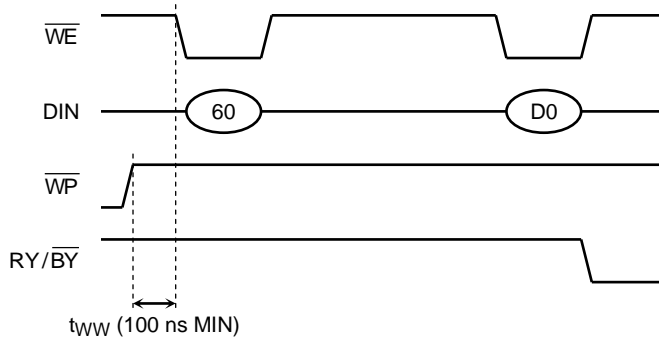

Disable Erasing

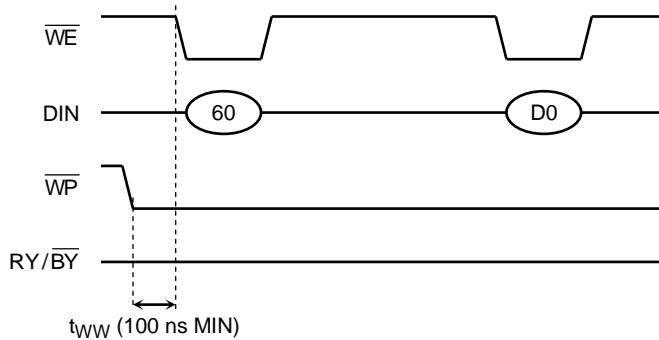

(11) When six address cycles are input

Although the device may read in a sixth address, it is ignored inside the chip.

Read operation

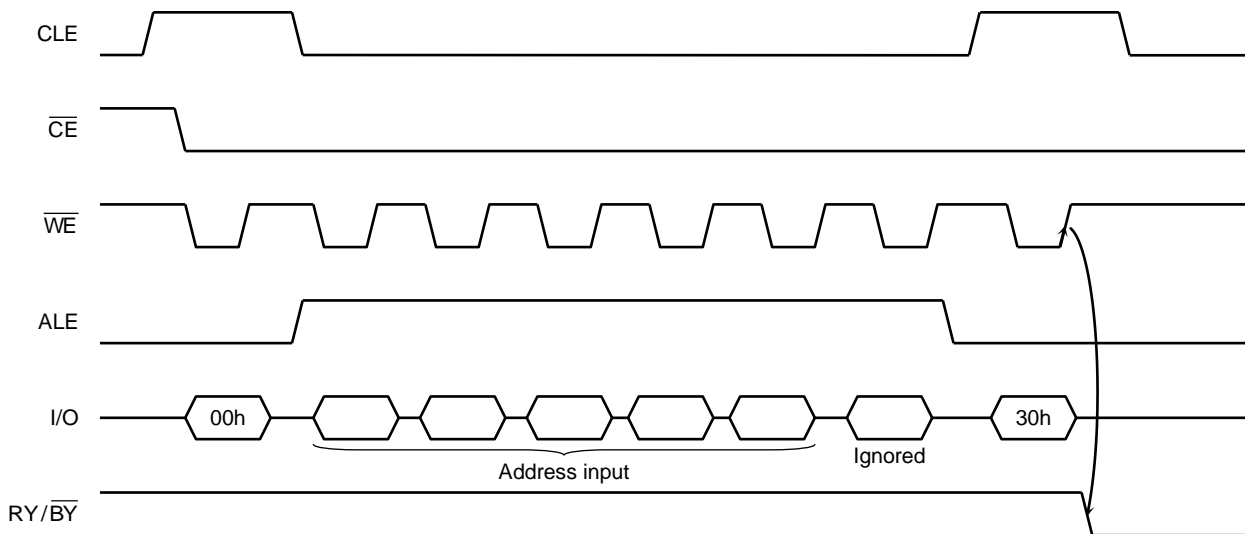

Program operation

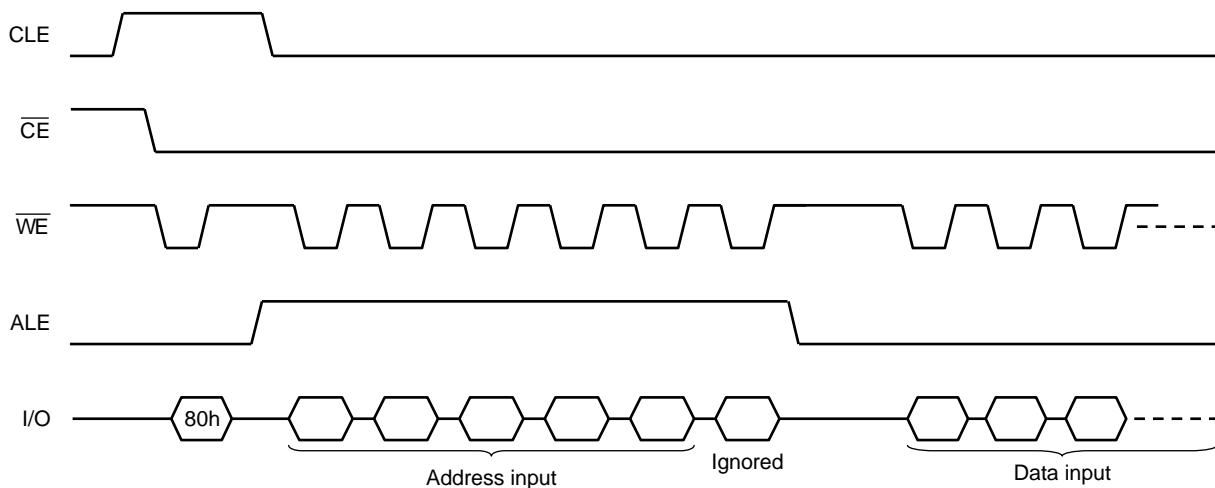

(12) Several programming cycles on the same page (Partial Page Program)

Each segment can be programmed individually as follows:

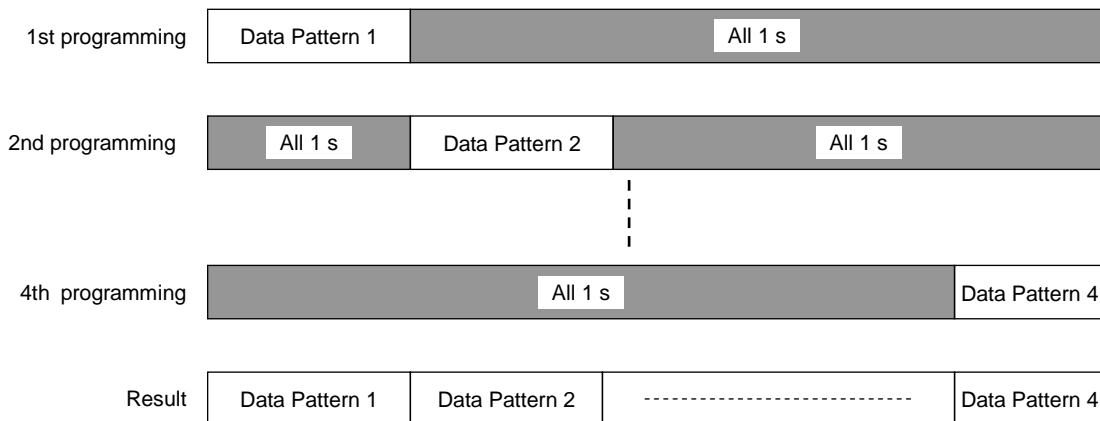

(13) Invalid blocks (bad blocks)

The device occasionally contains unusable blocks. Therefore, the following issues must be recognized:

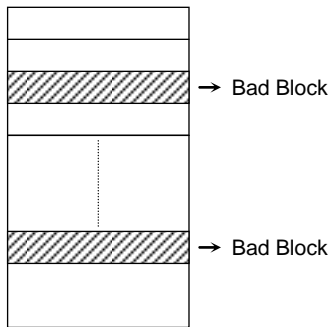

Please do not perform an erase operation to bad blocks. It may be impossible to recover the bad block information if the information is erased.

Check if the device has any bad blocks after installation into the system. Refer to the test flow for bad block detection. Bad blocks which are detected by the test flow must be managed as unusable blocks by the system.

A bad block does not affect the performance of good blocks because it is isolated from the bit lines by select gates.

The number of valid blocks over the device lifetime is as follows:

	MIN	TYP.	MAX	UNIT
Valid (Good) Block Number	4016	—	4096	Block

Bad Block Test Flow

Regarding invalid blocks, bad block mark is in whole pages. Please read one column of any page in each block. If the data of the column is 00 (Hex), define the block as a bad block

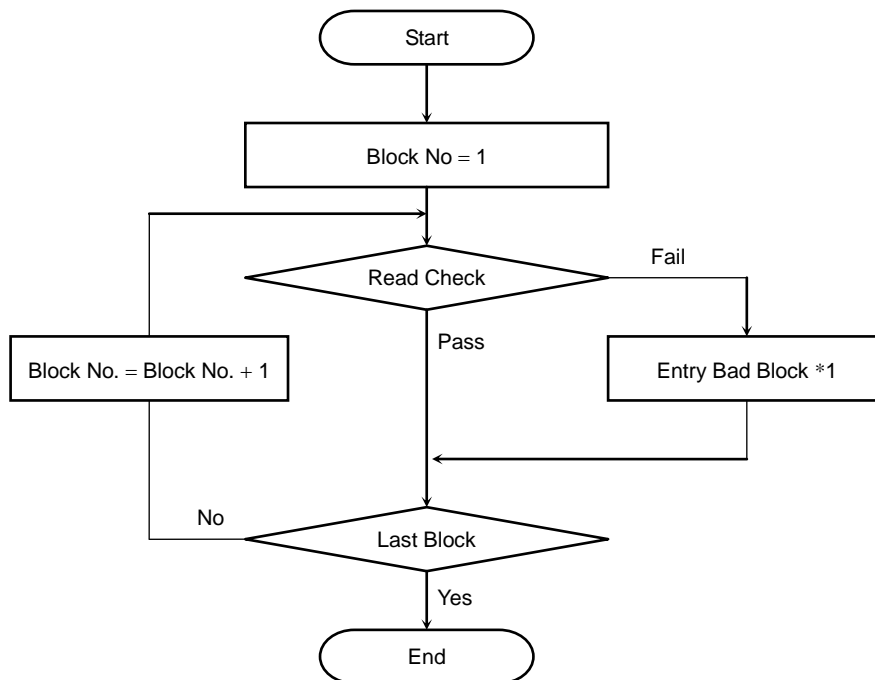

*1: No erase operation is allowed to detected bad blocks

(14) Failure phenomena for Program and Erase operations

The device may fail during a Program or Erase operation.

The following possible failure modes should be considered when implementing a highly reliable system.

FAILURE MODE		DETECTION AND COUNTERMEASURE SEQUENCE
Block	Erase Failure	Status Read after Erase → Block Replacement
Page	Programming Failure	Status Read after Program → Block Replacement
Read	9bit Failure(uncorrectable error)	Uncorrectable ECC error

- ECC: Error Correction Code. 8 bit correction per 528Bytes is executed in a device.
- Block Replacement

Program

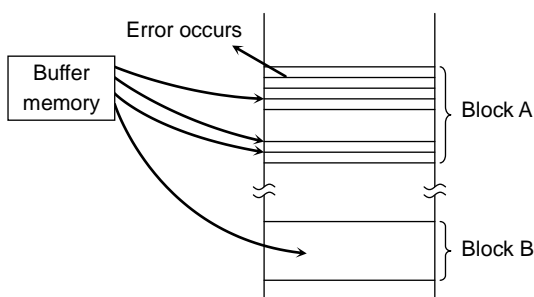

When an error happens in Block A, try to reprogram the data into another Block (Block B) by loading from an external buffer. Then, prevent further system accesses to Block A (by creating a bad block table or by using another appropriate scheme).

Erase

When an error occurs during an Erase operation, prevent future accesses to this bad block (again by creating a table within the system or by using another appropriate scheme).

- (15) Do not turn off the power before write/erase operation is complete. Avoid using the device when the battery is low. Power shortage and/or power failure before write/erase operation is complete will cause loss of data and/or damage to data.
- (16) The number of valid blocks is on the basis of single plane operations, and this may be decreased with two plane operations.

Package Dimensions

P-TFBGA63-0911-0.80CZ

Unit: mm

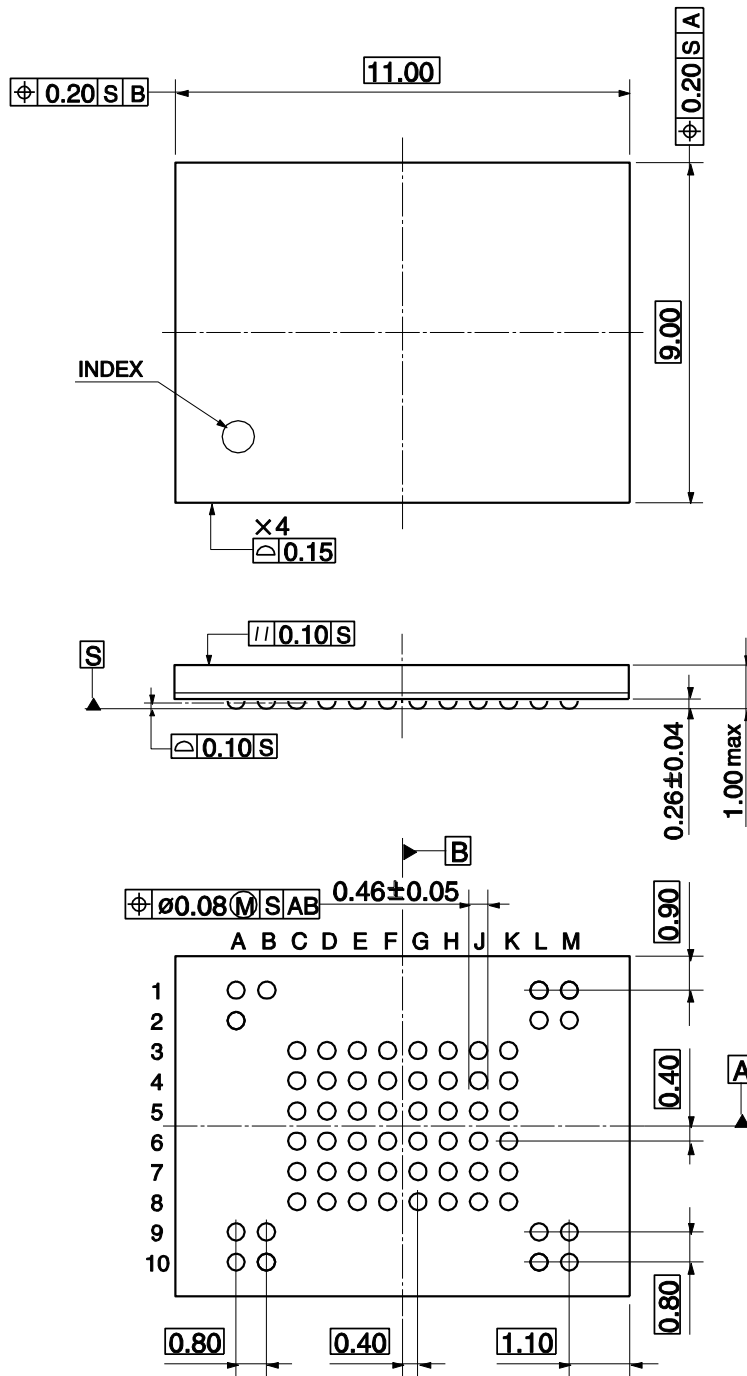

Weight: 0.154 g (typ.)

Revision History

Date	Rev.	Description
2013-02-15	0.10	Preliminary version
2014-03-15	1.00	Deleted TENTATIVE notation. Clarification for the Package Weight.

RESTRICTIONS ON PRODUCT USE

- Toshiba Corporation, and its subsidiaries and affiliates (collectively "TOSHIBA"), reserve the right to make changes to the information in this document, and related hardware, software and systems (collectively "Product") without notice.
- This document and any information herein may not be reproduced without prior written permission from TOSHIBA. Even with TOSHIBA's written permission, reproduction is permissible only if reproduction is without alteration/omission.
- Though TOSHIBA works continually to improve Product's quality and reliability, Product can malfunction or fail. Customers are responsible for complying with safety standards and for providing adequate designs and safeguards for their hardware, software and systems which minimize risk and avoid situations in which a malfunction or failure of Product could cause loss of human life, bodily injury or damage to property, including data loss or corruption. Before customers use the Product, create designs including the Product, or incorporate the Product into their own applications, customers must also refer to and comply with (a) the latest versions of all relevant TOSHIBA information, including without limitation, this document, the specifications, the data sheets and application notes for Product and the precautions and conditions set forth in the "TOSHIBA Semiconductor Reliability Handbook" and (b) the instructions for the application with which the Product will be used with or for. Customers are solely responsible for all aspects of their own product design or applications, including but not limited to (a) determining the appropriateness of the use of this Product in such design or applications; (b) evaluating and determining the applicability of any information contained in this document, or in charts, diagrams, programs, algorithms, sample application circuits, or any other referenced documents; and (c) validating all operating parameters for such designs and applications. **TOSHIBA ASSUMES NO LIABILITY FOR CUSTOMERS' PRODUCT DESIGN OR APPLICATIONS.**
- **PRODUCT IS NEITHER INTENDED NOR WARRANTED FOR USE IN EQUIPMENTS OR SYSTEMS THAT REQUIRE EXTRAORDINARILY HIGH LEVELS OF QUALITY AND/OR RELIABILITY, AND/OR A MALFUNCTION OR FAILURE OF WHICH MAY CAUSE LOSS OF HUMAN LIFE, BODILY INJURY, SERIOUS PROPERTY DAMAGE AND/OR SERIOUS PUBLIC IMPACT ("UNINTENDED USE").** Except for specific applications as expressly stated in this document, Unintended Use includes, without limitation, equipment used in nuclear facilities, equipment used in the aerospace industry, medical equipment, equipment used for automobiles, trains, ships and other transportation, traffic signaling equipment, equipment used to control combustions or explosions, safety devices, elevators and escalators, devices related to electric power, and equipment used in finance-related fields. **IF YOU USE PRODUCT FOR UNINTENDED USE, TOSHIBA ASSUMES NO LIABILITY FOR PRODUCT.** For details, please contact your TOSHIBA sales representative.
- Do not disassemble, analyze, reverse-engineer, alter, modify, translate or copy Product, whether in whole or in part.
- Product shall not be used for or incorporated into any products or systems whose manufacture, use, or sale is prohibited under any applicable laws or regulations.
- The information contained herein is presented only as guidance for Product use. No responsibility is assumed by TOSHIBA for any infringement of patents or any other intellectual property rights of third parties that may result from the use of Product. No license to any intellectual property right is granted by this document, whether express or implied, by estoppel or otherwise.
- **ABSENT A WRITTEN SIGNED AGREEMENT, EXCEPT AS PROVIDED IN THE RELEVANT TERMS AND CONDITIONS OF SALE FOR PRODUCT, AND TO THE MAXIMUM EXTENT ALLOWABLE BY LAW, TOSHIBA (1) ASSUMES NO LIABILITY WHATSOEVER, INCLUDING WITHOUT LIMITATION, INDIRECT, CONSEQUENTIAL, SPECIAL, OR INCIDENTAL DAMAGES OR LOSS, INCLUDING WITHOUT LIMITATION, LOSS OF PROFITS, LOSS OF OPPORTUNITIES, BUSINESS INTERRUPTION AND LOSS OF DATA, AND (2) DISCLAIMS ANY AND ALL EXPRESS OR IMPLIED WARRANTIES AND CONDITIONS RELATED TO SALE, USE OF PRODUCT, OR INFORMATION, INCLUDING WARRANTIES OR CONDITIONS OF MERCHANTABILITY, FITNESS FOR A PARTICULAR PURPOSE, ACCURACY OF INFORMATION, OR NONINFRINGEMENT.**
- Do not use or otherwise make available Product or related software or technology for any military purposes, including without limitation, for the design, development, use, stockpiling or manufacturing of nuclear, chemical, or biological weapons or missile technology products (mass destruction weapons). Product and related software and technology may be controlled under the applicable export laws and regulations including, without limitation, the Japanese Foreign Exchange and Foreign Trade Law and the U.S. Export Administration Regulations. Export and re-export of Product or related software or technology are strictly prohibited except in compliance with all applicable export laws and regulations.
- Please contact your TOSHIBA sales representative for details as to environmental matters such as the RoHS compatibility of Product. Please use Product in compliance with all applicable laws and regulations that regulate the inclusion or use of controlled substances, including without limitation, the EU RoHS Directive. **TOSHIBA ASSUMES NO LIABILITY FOR DAMAGES OR LOSSES OCCURRING AS A RESULT OF NONCOMPLIANCE WITH APPLICABLE LAWS AND REGULATIONS.**