

THB6128 Development Specification Proposal

1. Application: PWM current control stepping motor driver
2. Package: MFP30KR
3. Features

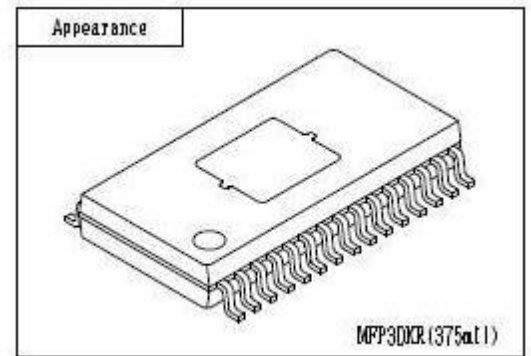

- 1 channel PWM current control stepping motor driver
- BiCDMOS process IC
- Output on-resistance(High side 0.3 Ω , Low side 0.25 Ω , Total 0.55 Ω ; Ta = 25°C, Io = 2.0 A)
- 2, 1-2, W1-2, 2W1-2, 4W1-2, 8W1-2, 16W1-2, 32W1-2 phase excitation are selectable
- Advance the excitation step with the only step signal input
- Available forward reverse control
- Iomax=2.2A
- Over current protection circuit
- Thermal shutdown circuit
- Input pull down resistance
- With reset pin and enable pin

4. Absolute Maximum Ratings at Ta = 25°C

Parameter	Symbol	Ratings	Unit
Supply voltage	VMmax	40	V
Output current	Iomax	2.2	A
Logic input voltage	VINmax	6	V
VREF input voltage	VREFmax	6	V
MO input voltage	VMOmax	6	V
DOWN input voltage	VDOmax	6	V
Operating temperature	Topg	-20 to +85	°C
Storage temperature	Tstg	-55 to +150	°C

5. Recommended Operating Range at Ta=25°C

Parameter	Symbol	Ratings	Unit
Supply voltage range	VM	9 to 32	V
Logic input voltage range	VIN	0 to 5	V
VREF input voltage range	VREF	0 to 3	V

6. Electrical Characteristics at Ta =25°C, VM=24V, VREF=1.5V

Parameter	Symbol	Conditions	min	typ	max	Unit
Standby mode current drain	IMstn	ST="L"		70		μA
current drain	IM	ST="H", OE="H", no load		4		mA
Thermal shutdown temperature	TSD	Design guarantee		180		°C
Thermal hysteresis width	ΔTSD	Design guarantee		40		°C
Logic pin input current	IinL1	VIN=0.8V		8		μA
	IinH1	VIN=5V		50		μA
Logic input high-level voltage	Vinh		2.0			V
Logic input low-level voltage	Vinl				0.8	V
FDT pin high-level voltage	Vfdth		3.5			V
FDT pin middle-level voltage	Vfdtm		1.1		3.1	V
FDT pin low-level voltage	Vfdtl				0.8	V
Chopping frequency	Fch	Cosc1=100pF		100		KHz
OSC1 pin charge/discharge current	Iosc1			10		μA
Chopping oscillator circuit threshold voltage	Vtup1			1		V
	Vtdown1			0.5		V
VREF pin input voltage	Iref	VREF=1.5V	-0.5			μA
DOWN output residual voltage	VolDO	I _{down} =1mA			400	mV
MO pin residual voltage	VolMO	I _{mo} =1mA			400	mV
Hold current switching frequency	Falert	Cosc2=1500pF		1.6		Hz
OSC2 pin charge/discharge current	Iosc2			10		μA
Hold current switching frequency threshold voltage	Vtup2			1		V
	Vtdown2			0.5		V
REG1 output voltage	Vreg1			5		V
REG2 output voltage	Vreg2			19		V
Blanking time	Tbl			1		μs
Output block						
Output on-resistance	Ronu	I _o =2.0A, high-side ON resistance		0.3		Ω
	Rond	I _o =2.0A, low-side ON resistance		0.25		Ω
Output leakage current	Ioleak	VM=36V			50	μA
Diode forward voltage	VD	ID=-2.0A		1		V
Current setting reference voltage	VRF	VREF=1.5V, Current ratio 100%		300		mV
Output short-circuit protection block						
Timer latch time	Tscp			256		μs

7. PIN ARRANGEMENT (Proposal)

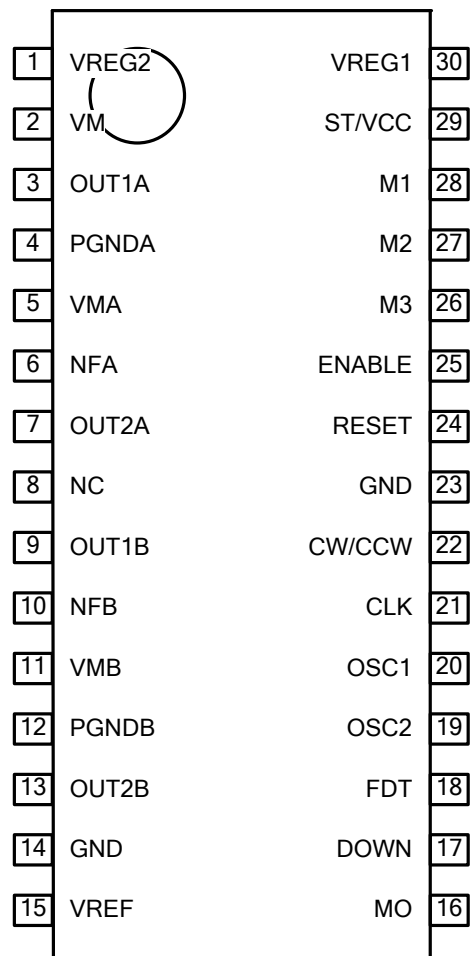

8. Pin Functions

Pin No.	Pin symbol	Pin Functions
17	DOWN	Holding current output
14, 23	SGND	Signal GND
20	OSC1	Chopping frequency setting capacitor connection
18	FDT	Decay mode select voltage input
15	VREF	Constant-current control reference voltage input
11	VMB	B phase motor supply connection
28	M1	Excitation-mode switching pin
27	M2	Excitation-mode switching pin
26	M3	Excitation-mode switching pin
13	OUT2B	B phase OUTB output
10	NFB	B phase current sense resistance connection
9	OUT1B	B phase OUTA output
12	PGNDB	B phase power GND
7	OUT2A	A phase OUTB output
6	NFA	A phase current sense resistance connection
3	OUT1A	A phase OUTA output
4	PGNDA	A phase power GND
25	ENABLE	Output enable signal input
24	RESET	RESET signal input
5	VMA	A phase motor supply connection
21	CLK	Clock pulse signal input
22	CW/CCW	Forward/Reverse signal input
19	OSC2	Holding current detection time setting capacitor connection
16	MO	Position detecting monitor
30	VREG1	Internal regulator capacitor connection
1	VREG2	Internal regulator capacitor connection
2	VM	Motor power connection
29	ST/VCC	Chip enable input

9. Description of functions



9-1) Stand-by function

When ST/VCC pin is at low levels, the IC enters stand-by mode, all logic is reset and output is turned OFF.

When ST/VCC pin is at high levels, the stand-by mode is released.

9-2) Step pin function

CLK pin step signal input allows advancing excitation step.

Input		Operation
ST/VCC	CLK	
L	*	Stand-by mode
H		Excitation step feed
H		Excitation step hold

9-3) Excitation setting method

Set the excitation setting as shown in the following table by setting M1 pin, M2 pin and M3 pin.

Input			Mode (Excitation)	Initial position	
M3	M2	M1		A phase current	B phase current
L	L	L	2 phase	100%	-100%
L	L	H	1-2 phase	100%	0%
L	H	L	W1-2 phase	100%	0%
L	H	H	2W1-2 phase	100%	0%
H	L	L	4W1-2 phase	100%	0%
H	L	H	8W1-2 phase	100%	0%
H	H	L	16W1-2 phase	100%	0%
H	H	H	32W1-2 phase	100%	0%

The initial position is also the default state at start-up and excitation position at counter-reset in each excitation mode.

9-4) Output current setting

Output current is set as shown below by the VREF pin (applied voltage) and a resistance value between NFA (B) pin and GND.

$$I_{out} = (VREF / 5) / \text{NFA (B) resistance}$$

※* The setting value above is a 100% output current in each excitation mode.

(Example) When VREF=1.5V and NFA (B) resistance is 0.3 Ω, the setting current is shown below.

$$I_{out} = (1.5 \text{ V} / 5) / 0.3 \Omega = 1.0 \text{ A}$$

9-5) Output enable function

When the ENABLE pin is set Low, the output is forced OFF and goes to high impedance. However, the internal logic circuits are operating, so the excitation position proceeds when the CLK is input. Therefore, when ENABLE pin is returned to High, the output level conforms to the excitation position proceeded by the CLK input.

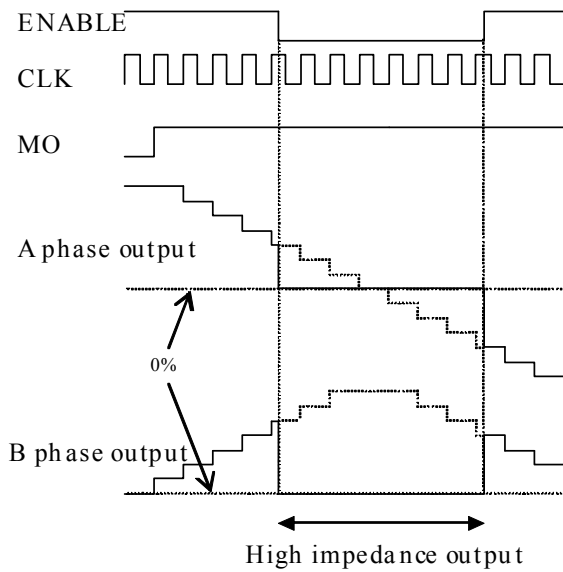

9-6) Reset function

When the RESET pin is set Low, the output goes to initial mode and the excitation position is fixed in the initial position for CLK pin and CW/CCW pin input. MO pin outputs at low levels at the initial position. (Open drain connection)

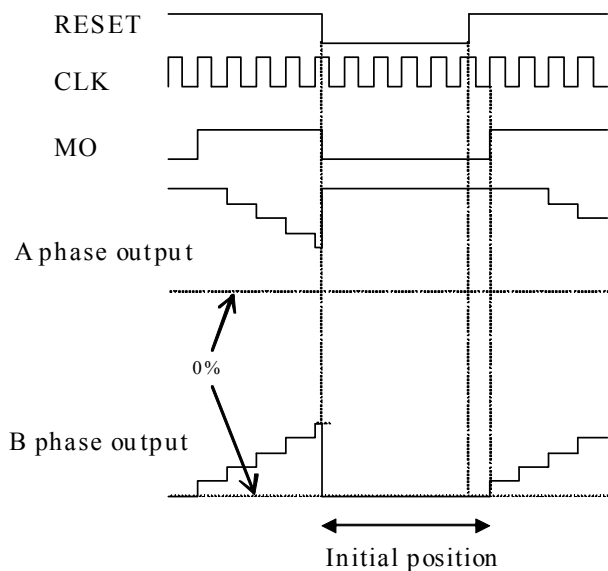

9-7) Forward/reverse switching function

CW/CCW	Operation
L	CW
H	CCW

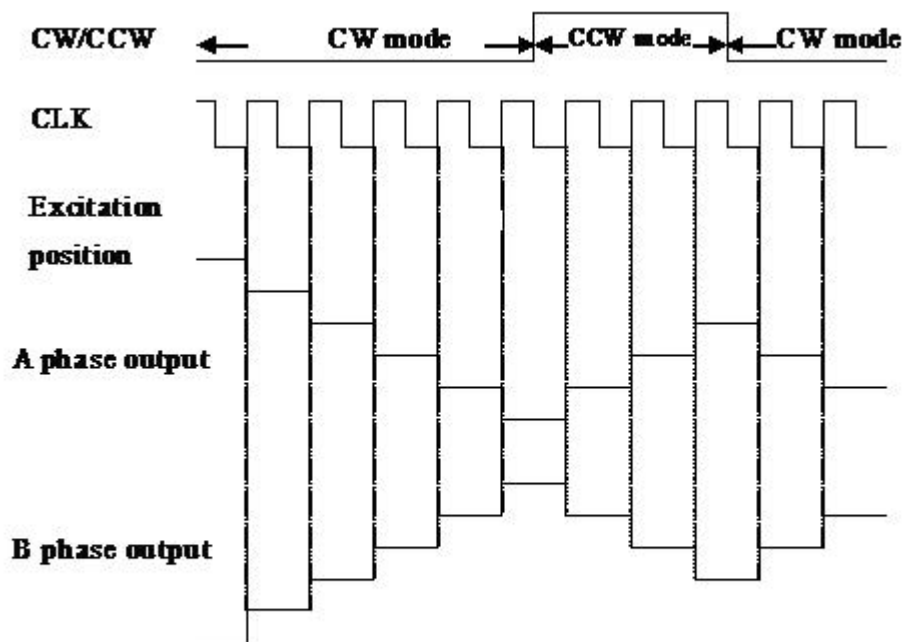

The internal D/A converter proceeds by a bit on the rising edge of the step signal input to the CLK pin. In addition, CW and CCW mode are switched by CW and CCW pin setting.

In CW mode, the B phase current is delayed by 90° relative to the A phase current. In CCW mode, the B phase current is advanced by 90° relative to the A phase current.

9-8) DECAY mode setting

Current DECAY method is selectable as shown below by applied voltage to the FDT pin.

FDT voltage	DECAY method
3.5V to	SLOW DECAY
1.1V to 3.1V or OPEN	MIXED DECAY
to 0.8V	FAST DECAY

9-9) DOWN, MO output pin

Output pin is an open drain connection. Each pin is turned ON at predetermined state and outputs at low levels.

Pin state	DOWN	MO
Low	Holding current state	Initial position
OFF	Normal state	Non initial position

9-10) Chopping frequency setting function

Chopping frequency is set as shown below by a capacitor between OSC1 pin and GND.

$$F_{cp} = 1 / (C_{osc1} / 10 \times 10^{-6}) \text{ (Hz)}$$

(Example) When $C_{osc1} = 100 \text{ pF}$, the chopping frequency is shown below.

$$F_{cp} = 1 / (100 \times 10^{-12} / 10 \times 10^{-6}) = 100 \text{ (kHz)}$$

9-11) Output current vector locus (1 step normalized 90°)

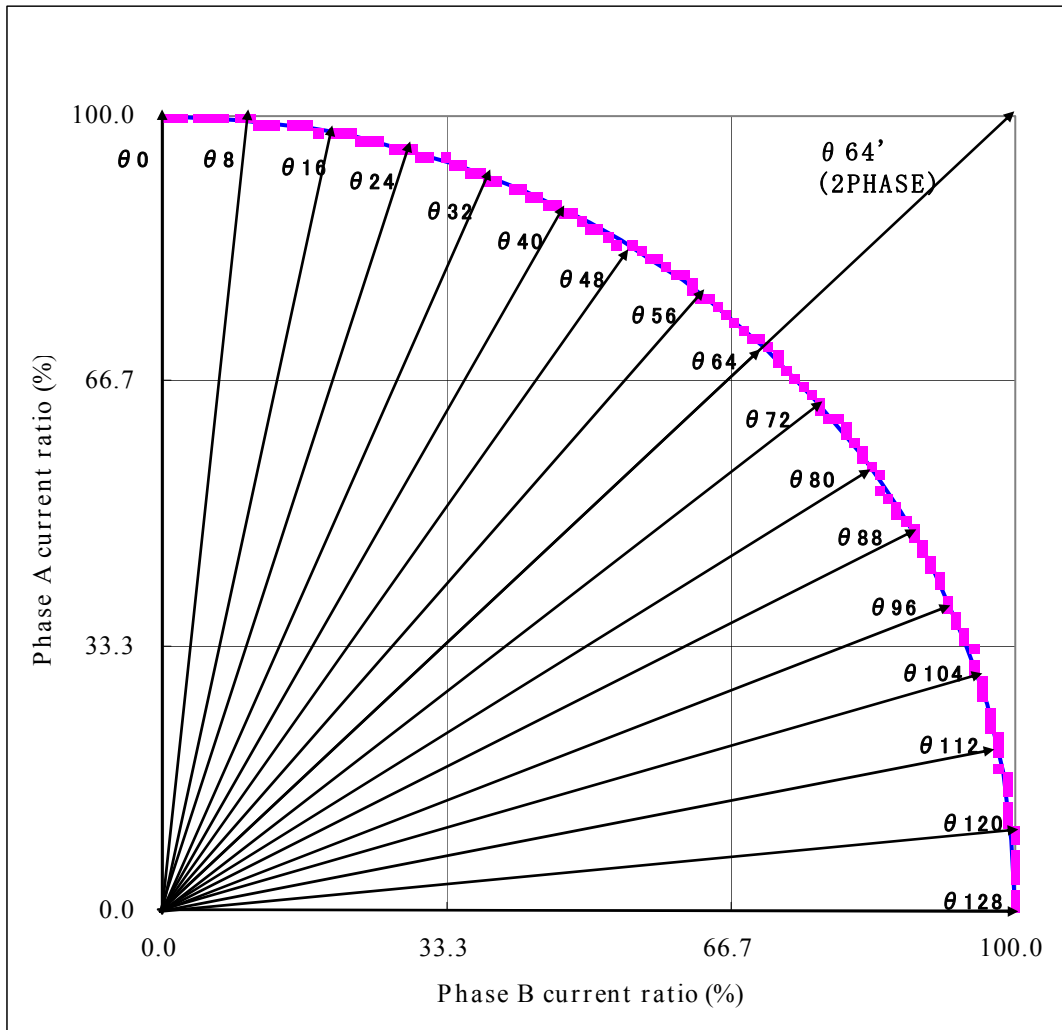

Current setting ratio in each excitation mode

STFP	2W1-2 phase(%)		16W1-2 phase(%)		8W1-2 phase(%)		4W1-2 phase(%)		2W1-2 phase(%)		W1-2 phase(%)		1-2 phase(%)		2 phase(%)		STFP	2W1-2 phase(%)		16W1-2 phase(%)		8W1-2 phase(%)		4W1-2 phase(%)		2W1-2 phase(%)		W1-2 phase(%)		1-2 phase(%)		2 phase(%)	
	Ach	Bch	Ach	Bch	Ach	Bch	Ach	Bch	Ach	Bch	Ach	Bch	Ach	Bch	Ach	Bch		Ach	Bch	Ach	Bch	Ach	Bch	Ach	Bch	Ach	Bch	Ach	Bch	Ach	Bch	Ach	Bch
θ0	100	0	100	0	100	0	100	0	100	0	100	0	100	0	100	0	θ65	70	72														
θ1	100	1															θ66	69	72	69	72												
θ2	100	2	100	2													θ67	68	73														
θ3	100	4															θ68	67	74	67	74	67	74										
θ4	100	5	100	5	100	5											θ69	66	75														
θ5	100	6															θ70	65	76	65	76												
θ6	100	7	100	7													θ71	64	77														
θ7	100	9															θ72	63	77	63	77	63	77	63	77								
θ8	100	10	100	10	100	10	100	10									θ73	62	78														
θ9	99	11															θ74	62	79	62	79												
θ10	99	12	99	12													θ75	61	80														
θ11	99	13															θ76	60	80	60	80	60	80										
θ12	99	15	99	15	99	15											θ77	59	81														
θ13	99	16															θ78	58	82	58	82												
θ14	99	17	99	17													θ79	57	82														
θ15	98	18															θ80	56	83	56	83	56	83	56	83	56	83						
θ16	98	20	98	20	98	20	98	20	98	20							θ81	55	84														
θ17	98	21															θ82	53	84	53	84												
θ18	98	22	98	22													θ83	52	85														
θ19	97	23															θ84	51	86	51	86	51	86										
θ20	97	24	97	24	97	24											θ85	50	86														
θ21	97	25															θ86	49	87	49	87												
θ22	96	27	96	27													θ87	48	88														
θ23	96	28															θ88	47	88	47	88	47	88	47	88								
θ24	96	29	96	29	96	29	96	29									θ89	46	89														
θ25	95	30															θ90	45	89	45	89												
θ26	95	31	95	31													θ91	44	90														
θ27	95	33															θ92	43	90	43	90	43	90										
θ28	94	34	94	34	94	34											θ93	42	91														
θ29	94	35															θ94	41	91	41	91												
θ30	93	36	93	36													θ95	39	92														
θ31	93	37															θ96	38	92	38	92	38	92	38	92	38	92	38	92				
θ32	92	38	92	38	92	38	92	38	92	38	92	38					θ97	37	93														
θ33	92	39															θ98	36	93	36	93												
θ34	91	41	91	41													θ99	35	94														
θ35	91	42															θ100	34	94	34	94	34	94										
θ36	90	43	90	43	90	43											θ101	33	95														
θ37	90	44															θ102	31	95	31	95												
θ38	89	45	89	45													θ103	30	95														
θ39	89	46															θ104	29	96	29	96	29	96	29	96								
θ40	88	47	88	47	88	47	88	47									θ105	28	96														
θ41	88	48															θ106	27	96	27	96												
θ42	87	49	87	49													θ107	25	97														
θ43	86	50															θ108	24	97	24	97	24	97										
θ44	86	51	86	51	86	51											θ109	23	97														
θ45	85	52															θ110	22	98	22	98												
θ46	84	53	84	53													θ111	21	98														
θ47	84	55															θ112	20	98	20	98	20	98	20	98	20	98						
θ48	83	56	83	56	83	56	83	56	83	56							θ113	18	98														
θ49	82	57															θ114	17	99	17	99												
θ50	82	58	82	58													θ115	16	99														
θ51	81	59															θ116	15	99	15	99	15	99										
θ52	80	60	80	60	80	60											θ117	13	99														
θ53	80	61															θ118	12	99	12	99												
θ54	79	62	79	62													θ119	11	99														
θ55	78	62															θ120	10	100	10	100	10	100	10	100								
θ56	77	63	77	63	77	63	77	63									θ121	9	100														
θ57	77	64															θ122	7	100	7	100												
θ58	76	65	76	65													θ123	6	100														
θ59	75	66															θ124	5	100	5	100	5	100										
θ60	74	67	74	67	74	67											θ125	4	100														
θ61	73	68															θ126	2	100	2	100												
θ62	72	69	72	69													θ127	1	100														
θ63	72	70															θ128	0	100	0	100	0	100	0	100	0	100	0	100	0	100		
θ64	71	71	71	71	71	71	71	71	71	71	71	71	71	71	71	71	100	100															

9-12) Current wave example in each excitation mode (2 phase, 1-2 phase, W1-2 phase, 4W1-2 phase)

2 phase excitation (CW mode)

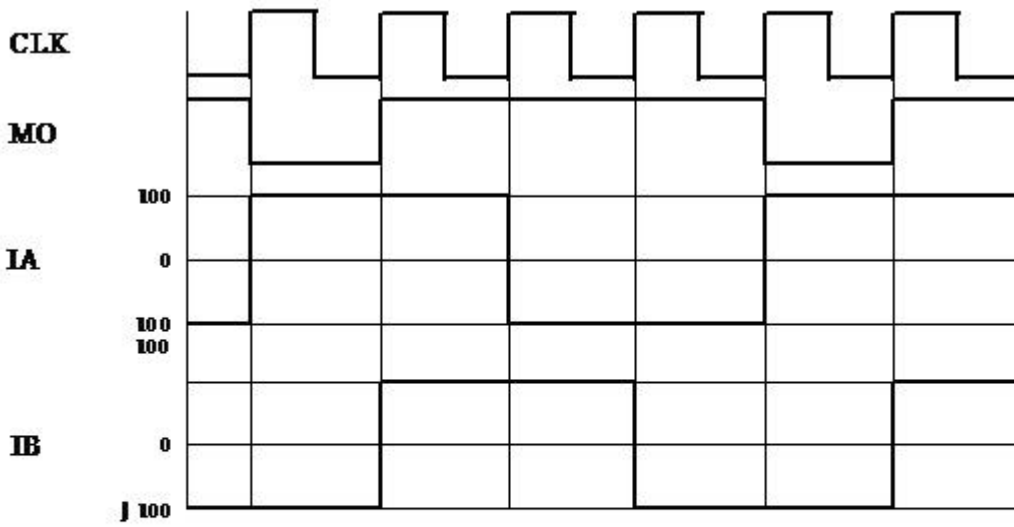

1-2 phase excitation (CW mode)

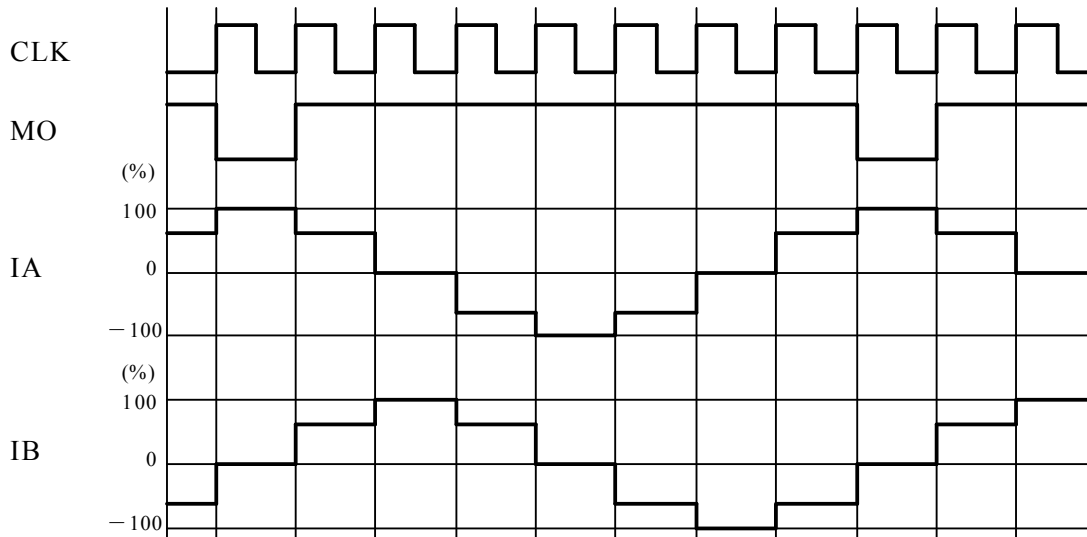

W1-2 phase excitation (CW mode)

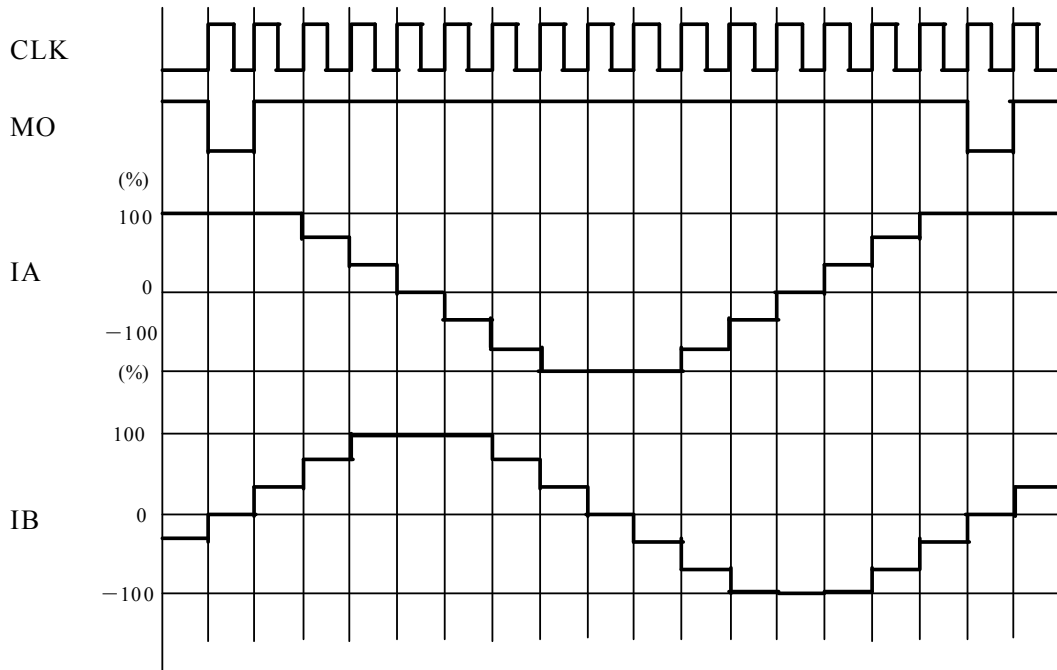

4W1-2 phase excitation (CW mode)

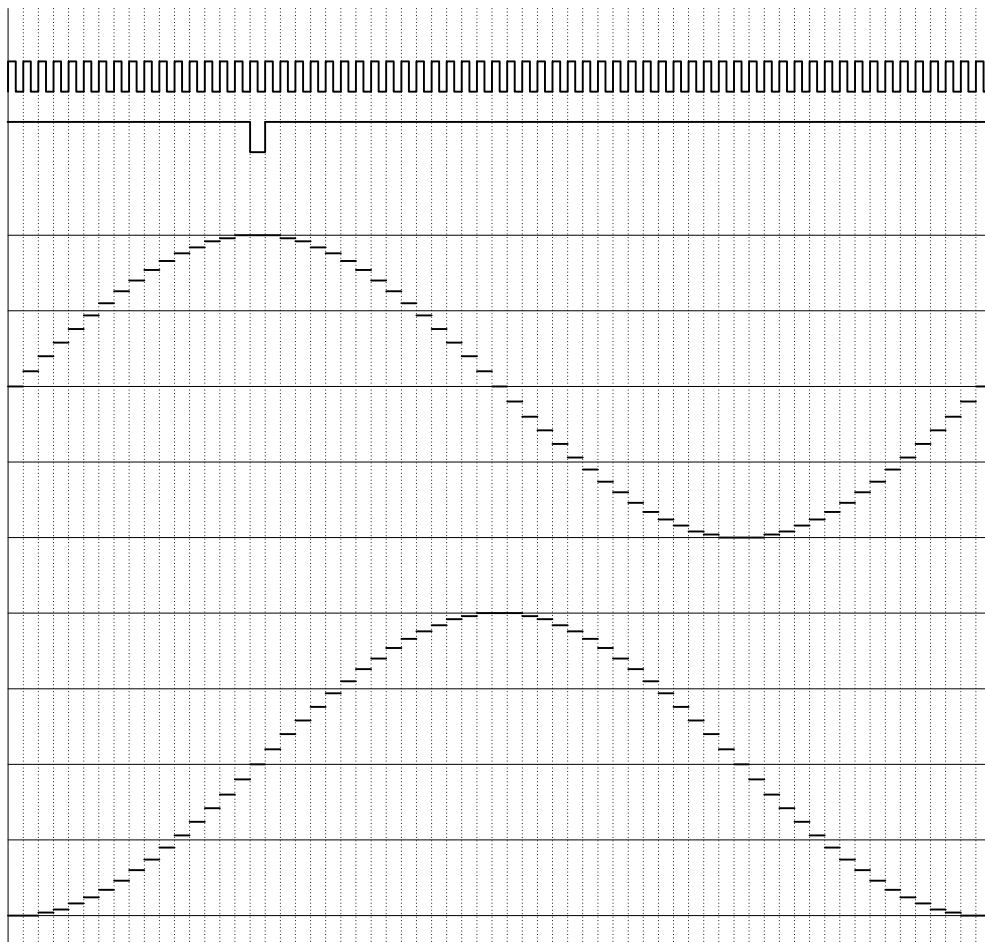

9-13) Output short-circuit protection circuit

Build-in output short-circuit protection circuit makes output to enter in stand-by mode. This function prevents the IC from damaging when the output shorts circuit by a voltage short or a ground short, etc. When output short state is detected, short-circuit detection circuit starts the operating and output is once turned OFF. After the timer latch time (typ: 256us), output is turned ON again. Still the output is at short state, the output is turned OFF and fixed in stand-by mode.

When output is fixed in stand-by mode by output short protection circuit, output is released the latch by setting ST/VCC="L".

9-14) Open-drain pin for switching holding current

The output pin is an open drain connection.

This pin is turned ON when no rising edge of CLK between the input signals while a period determined by a capacitor between OSC2 and GND, and outputs at low levels.

The open-drain output in once turned ON, is turned OFF at the next rising edge of CLK.

Holding current switching time (Tdown) is set as shown below by a capacitor between OSC2 pin and GND.

$$T_{\text{down}} = C_{\text{osc2}} \times 0.4 \times 10^9 \text{ (s)}$$

(Example) When $C_{\text{osc2}}=1500\text{pF}$, the holding current switching time is shown below.

$$T_{\text{down}} = 1500 \text{ pF} \times 0.4 \times 10^9 = 0.6 \text{ (s)}$$

10. Current control operation

10-1) SLOW DECAY current control operation

When FDT pin voltage is a voltage over 3.5 V, the constant-current control is operated in SLOW DECAY mode.

(Sine-wave increasing direction)

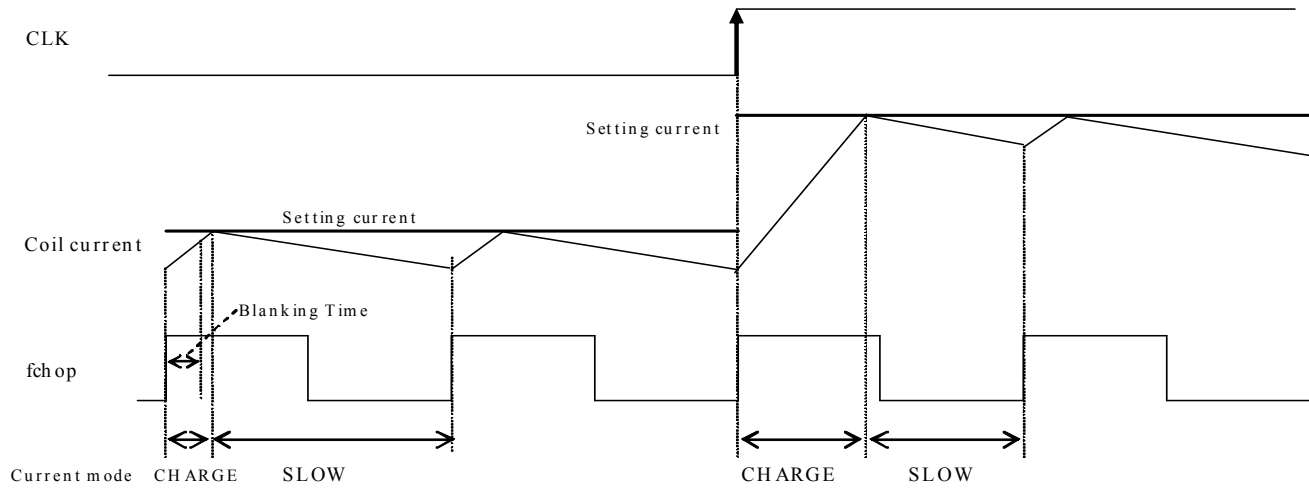

(Sine-wave decreasing direction)

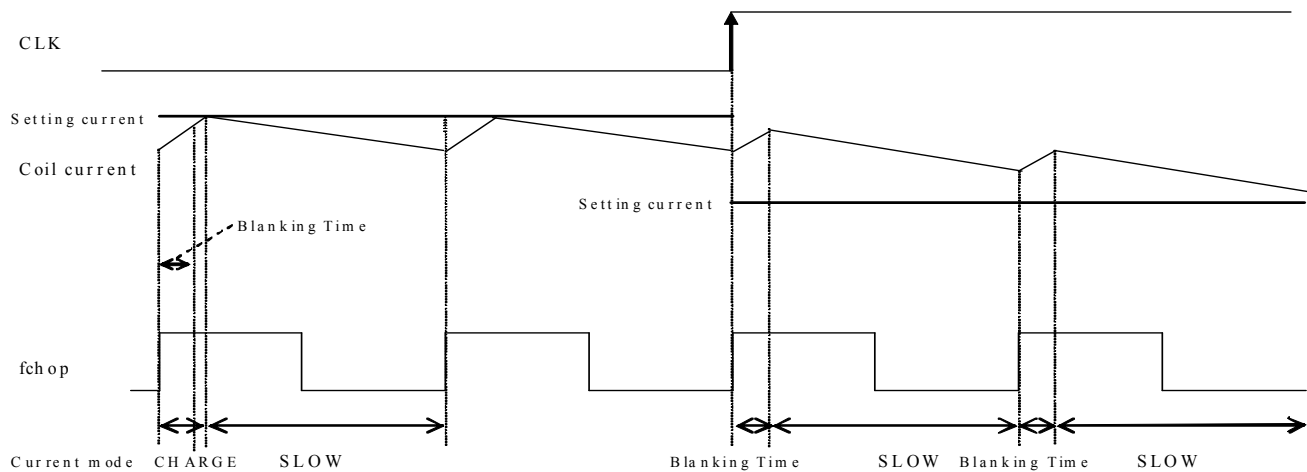

Each of current modes operates with the follow sequence.

- The IC enters CHARGE mode at a rising edge of the chopping oscillation.

(A period of CHARGE mode (Blanking Time) is forcibly present in approximately 1 μ s, regardless of the current value of the coil current(ICOIL)and set current (IREF)).

- After the period of the blanking time, the IC operates in CHARGE mode until $ICOIL \geq IREF$. After that, the mode switches to the SLOW DECAY mode and the coil current is attenuated until the end of a chopping period.

At the constant-current control in SLOW DECAY mode, following to the setting current from the coil current may take time (or not follow) for the current delay attenuation.

10-2) FAST DECAY current control operation

When FDT pin voltage is a voltage under 0.8V, the constant-current control is operated in FAST DECAY mode.

(Sine-wave increasing direction)

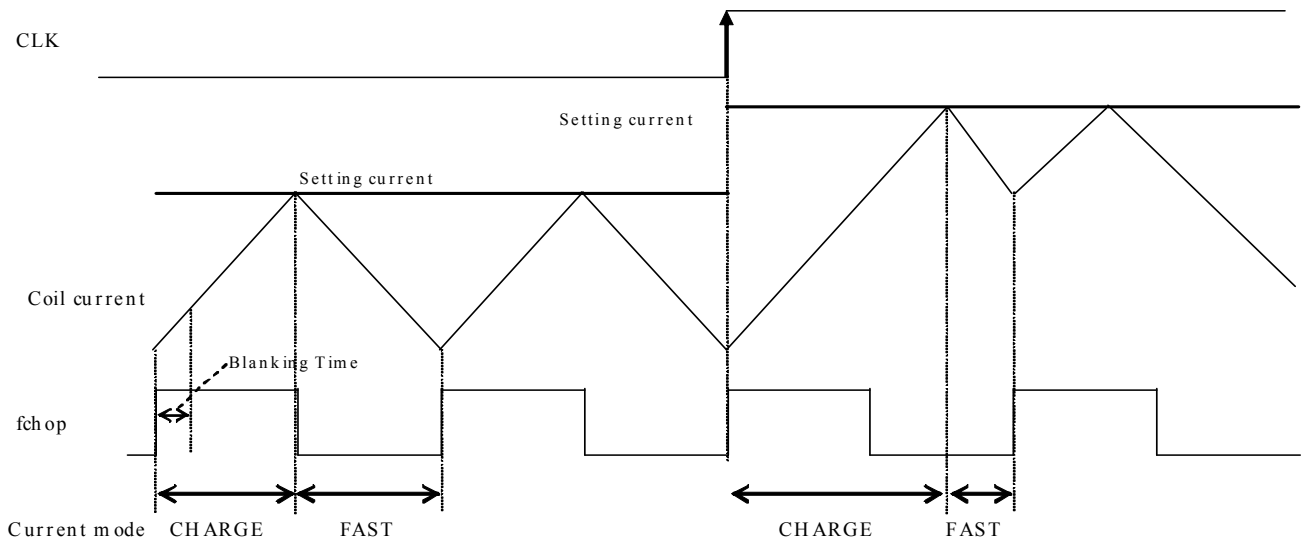

(Sine-wave decreasing direction)

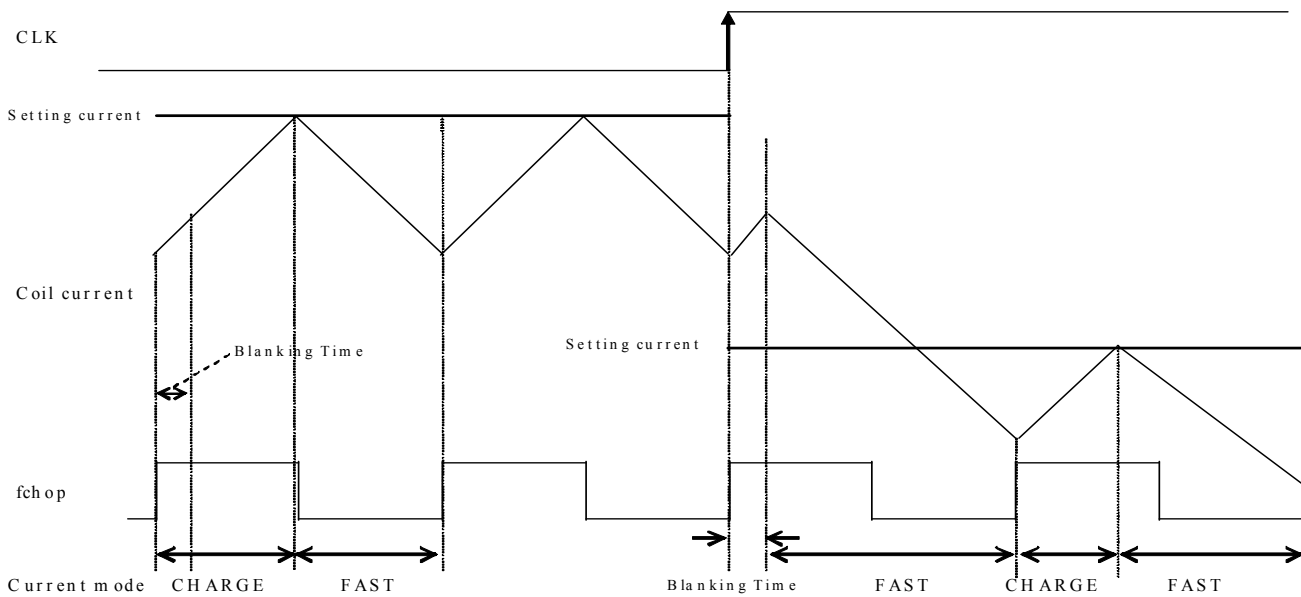

Each of current modes operates with the follow sequence.

- The IC enters CHARGE mode at a rising edge of the chopping oscillation.
(A period of CHARGE mode (Blanking Time) is forcibly present in approximately 1 μ s, regardless of the current value of the coil current (ICOIL) and set current (IREF)).
- After the period of the blanking time, The IC operates in CHARGE mode until $ICOIL \geq IREF$. After that, the mode switches to the FAST DECAY mode and the coil current is attenuated until the end of a chopping period.

At the constant-current control in FAST DECAY mode, following to the setting current from the coil current takes short-time for the current fast attenuation, but, the current ripple value may be higher.

10-3) MIXED DECAY current control operation

When FDT pin voltage is a voltage between 1.1 V to 3.1 V or OPEN, the constant-current control is operated in MIXED DECAY mode. (Sine-wave increasing direction)

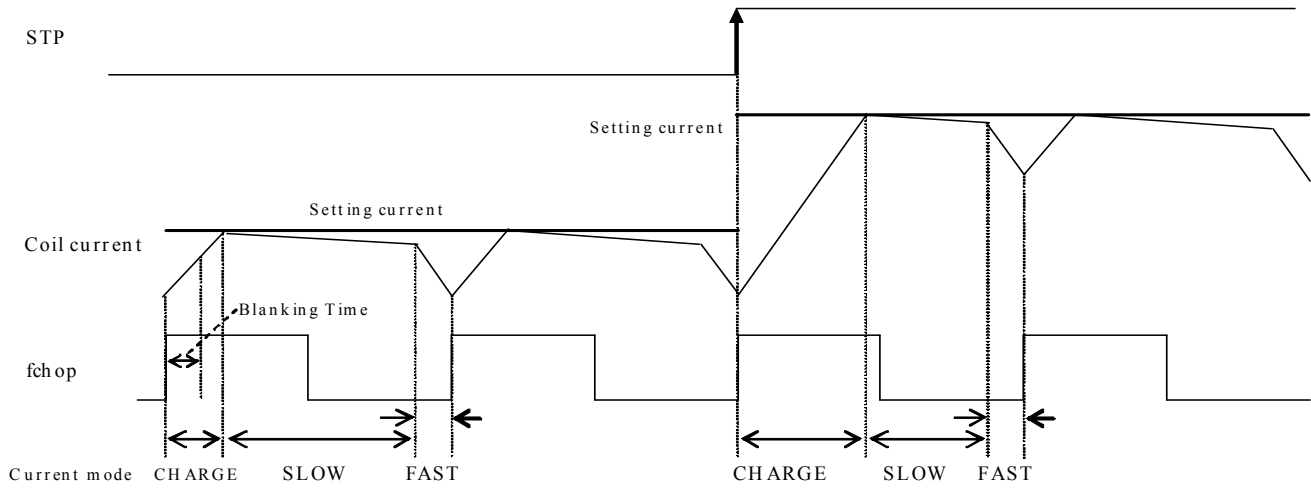

(Sine-wave decreasing direction)

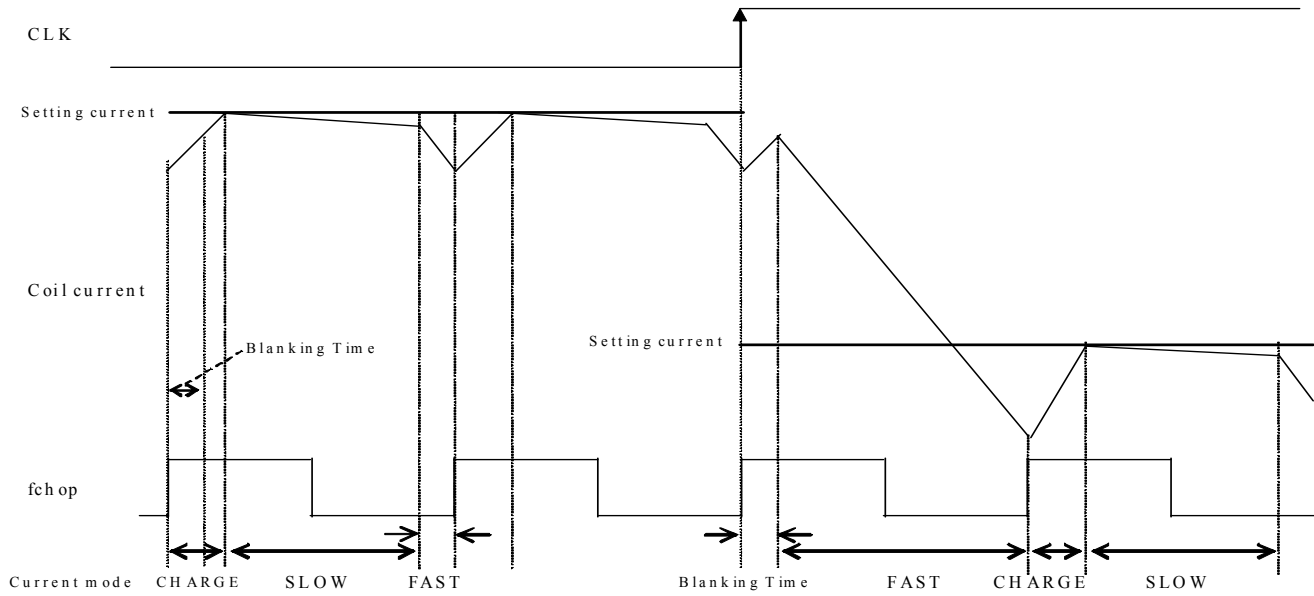

Each of current modes operates with the follow sequence.

- The IC enters CHARGE mode at a rising edge of the chopping oscillation.

(A period of CHARGE mode (Blanking Time) is forcibly present in approximately 1 μ s, regardless of the current value of the coil current (ICOIL) and set current (IREF)).

- In a period of Blanking Time, the coil current (ICOIL) and the setting current (IREF) are compared.

If an $ICOIL < IREF$ state exists during the charge period:

The IC operates in CHAGE mode until $ICOIL \geq IREF$. After that, it switches to SLOW DECAY mode and then switches to FAST DECAY mode in the last approximately 1 μ s of the period.

If no $ICOIL < IREF$ state exists during the charge period:

The IC switches to FAST DECAY mode and the coil current is attenuated with the FAST DECAY operation until the end of a chopping period.

The above operation is repeated.

Normally, in the sine wave increasing direction the IC operates in SLOW (+FAST) DECAY mode, and in the sine wave decreasing direction the IC operates in FAST DECAY mode until the current is attenuated and reaches the set value and the IC operates in SLOW (+FAST) DECAY mode.

11. Block diagram

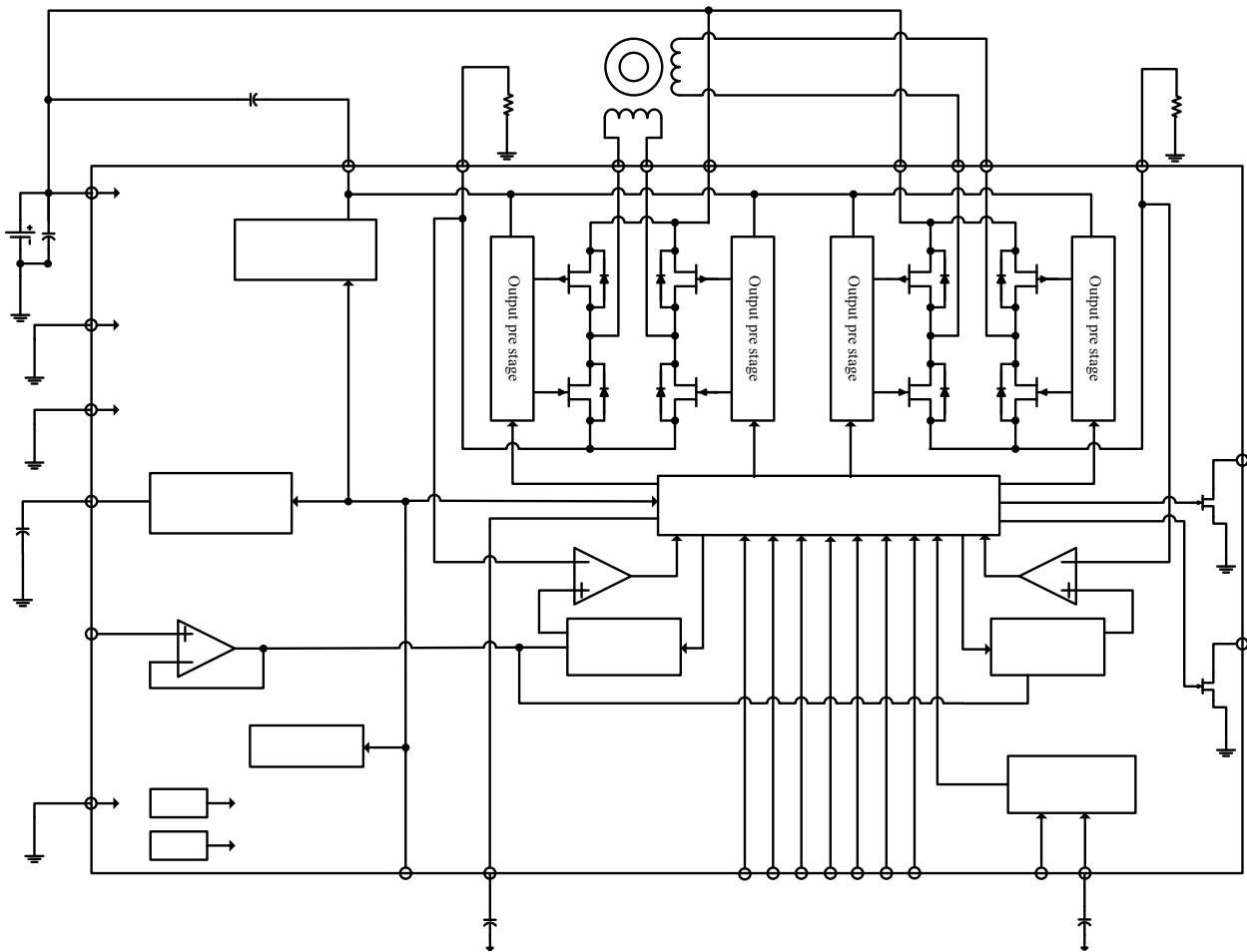

12. Wiring diagram

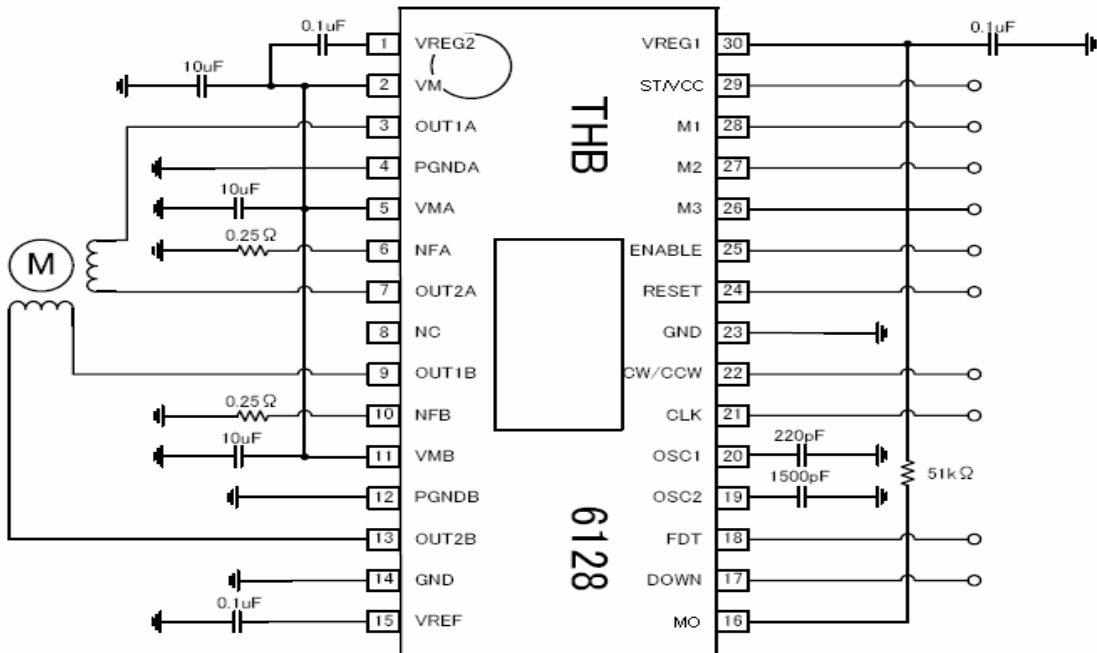

13. Package Dimensions

