

Application Specific Discretos
A.S.D.TM

TRANSIENT VOLTAGE SUPPRESSOR
FOR SLIC PROTECTION

FEATURES

- DUAL BIDIRECTIONAL CROWBAR PROTECTION.
- PEAK PULSE CURRENT :
- I_{PP} = 75 A, 10/1000 μs.
- HOLDING CURRENT = 150 mA min
- BREAKDOWN VOLTAGE = 200 V min.
- BREAKOVER VOLTAGE = 290 V max.
- MONOLITHIC DEVICE.

DESCRIPTION

This monolithic protection device has been especially designed to protect subscriber line cards. The THBT200 device is particularly suitable to protect ring generator relay against transient overvoltages.

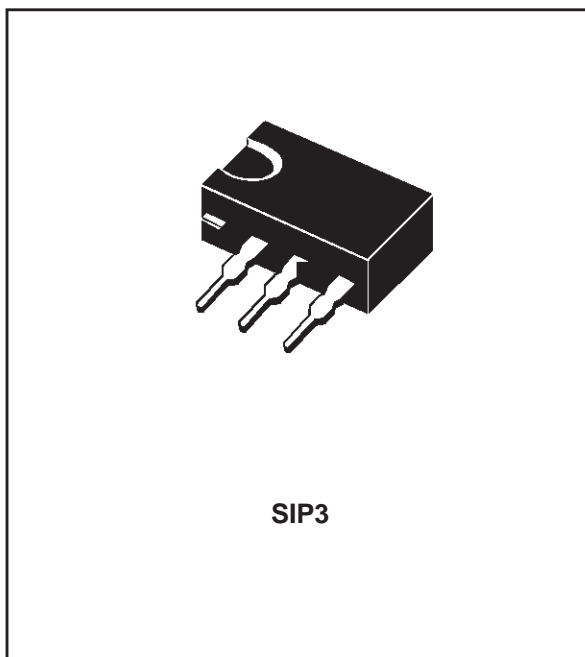

COMPLIES WITH THE FOLLOWING STANDARDS :

CCITT K20 :	10/700 μs	1kV
	5/310 μs	25A
VDE 0433 :	10/700 μs	2kV
	5/310 μs	50A
VDE 0878 :	1.2/50 μs	1.5kV
	1/20 μs	40A
FCC part 68 :	2/10 μs	2.5kV
	2/20 μs	225A (*)
BELLCORE		
TR-NWT-001089 :	2/10 μs	2.5kV
	2/10 μs	225A (*)
	10/1000 μs	1kV
	10/1000 μs	75A (*)

(*) with series resistors or PTC.

SCHEMATIC DIAGRAM

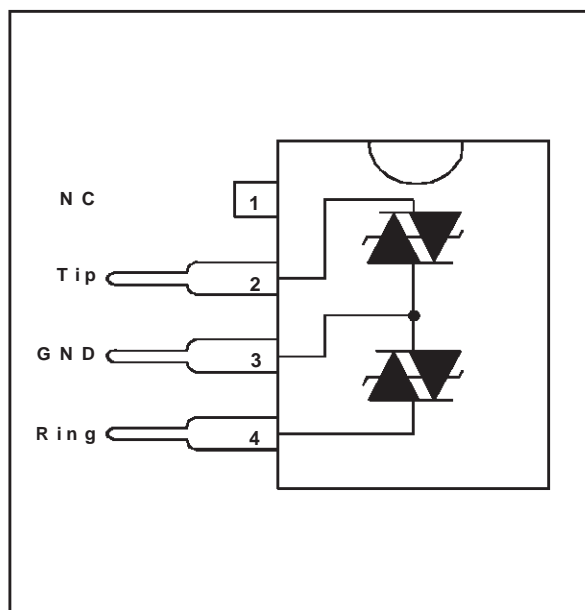

TM: ASD is trademarks of SGS-THOMSON Microelectronics.

THBT200S

ABSOLUTE MAXIMUM RATINGS ($T_{amb} = 25\text{ }^{\circ}\text{C}$)

Symbol	Parameter	Value	Unit
I_{PP}	Peak pulse current (see note 1)	10/1000 μs	75
		5/310 μs	125
		8/20 μs	150
		2/10 μs	225
I_{TSM}	Non repetitive surge peak on-state current ($F = 50\text{Hz}$)	$t_p = 20\text{ms}$	30 A
T_{stg} T_j	Storage temperature range Maximum junction temperature	- 40 to + 150 150	$^{\circ}\text{C}$
T_L	Maximum lead temperature for soldering during 10s	230	$^{\circ}\text{C}$

Note 1 : Pulse waveform :

10/1000 μs	$t_r=10\mu\text{s}$	$t_p=1000\mu\text{s}$
5/310 μs	$t_r=5\mu\text{s}$	$t_p=310\mu\text{s}$
2/10 μs	$t_r=2\mu\text{s}$	$t_p=10\mu\text{s}$

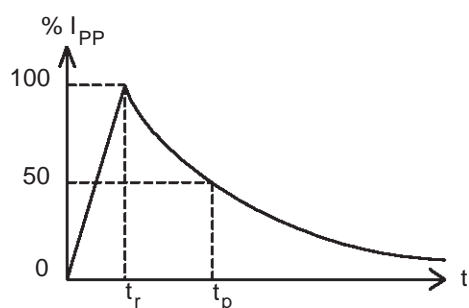

THERMAL RESISTANCE

Symbol	Parameter	Value	Unit
$R_{th(j-a)}$	Junction to ambient	80	$^{\circ}\text{C/W}$

ELECTRICAL CHARACTERISTICS ($T_{amb} = 25^{\circ}C$).

Symbol	Parameter
V_{RM}	Stand-off voltage
I_{RM}	Leakage current at V_{RM}
V_{BR}	Continuous reverse voltage
V_{BO}	Breakover voltage
I_H	Holding current
I_{BO}	Breakover current
I_{PP}	Peak pulse current
C	Capacitance

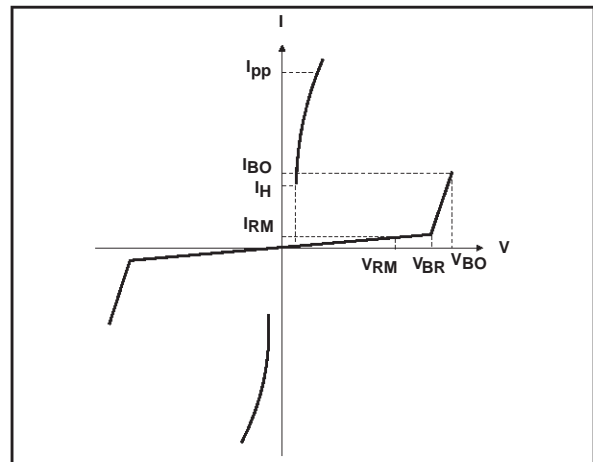

PARAMETERS RELATED TO ONE TRISIL (Between TIP and GND or RING and GND)

$I_{RM} @ V_{RM}$		$V_{BR} @ I_R$		$V_{BO} @ I_{BO}$			I_H	C
max.		min.		max.	min.	max.	min.	max.
				note 1			note 2	note 3
μA	V	V	mA	V	mA	mA	mA	pF
10	180	200	1	290	150	800	150	200

Note 1 : See reference test circuit 1 for I_{BO} and V_{BO} parameters.

Note 2 : See test circuit 2.

Note 3 : $V_R = 1V, F = 1MHz$.

REFERENCE TEST CIRCUIT 1 FOR I_{BO} and V_{BO} parameters :

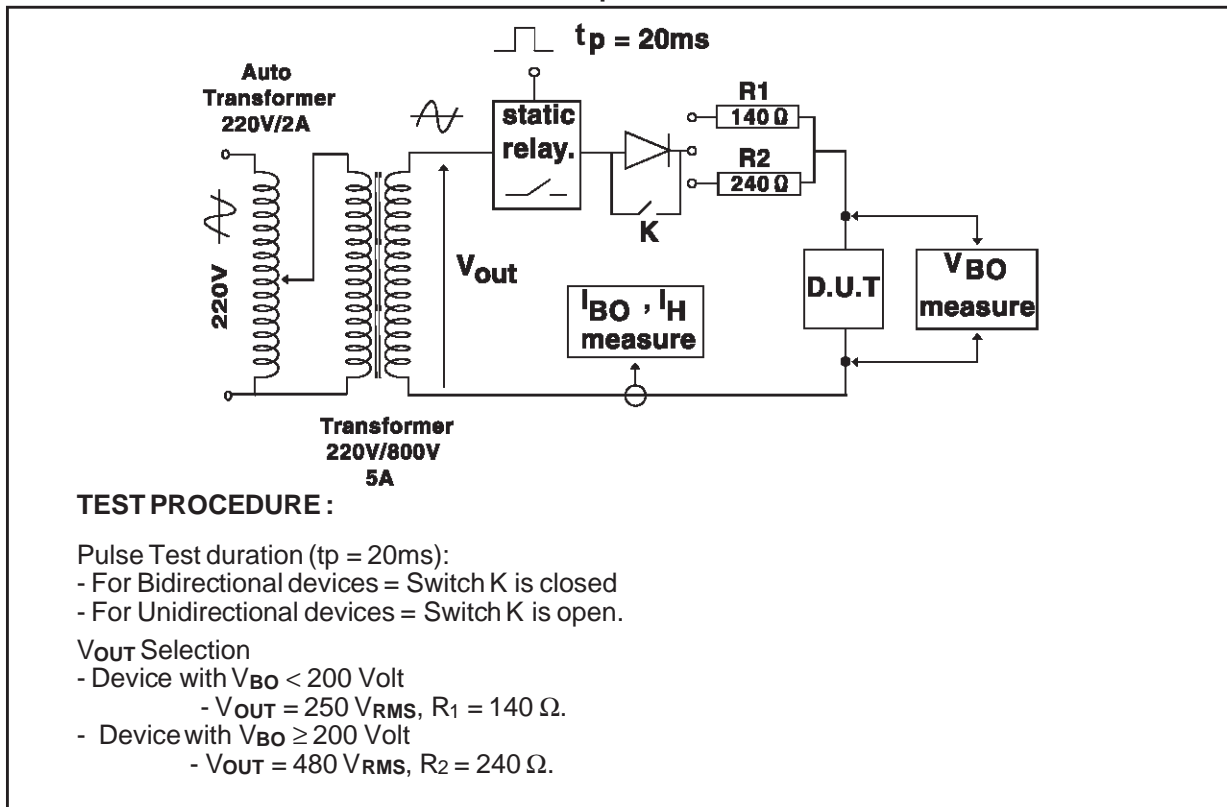

FUNCTIONAL HOLDING CURRENT (I_H) TEST CIRCUIT 2.

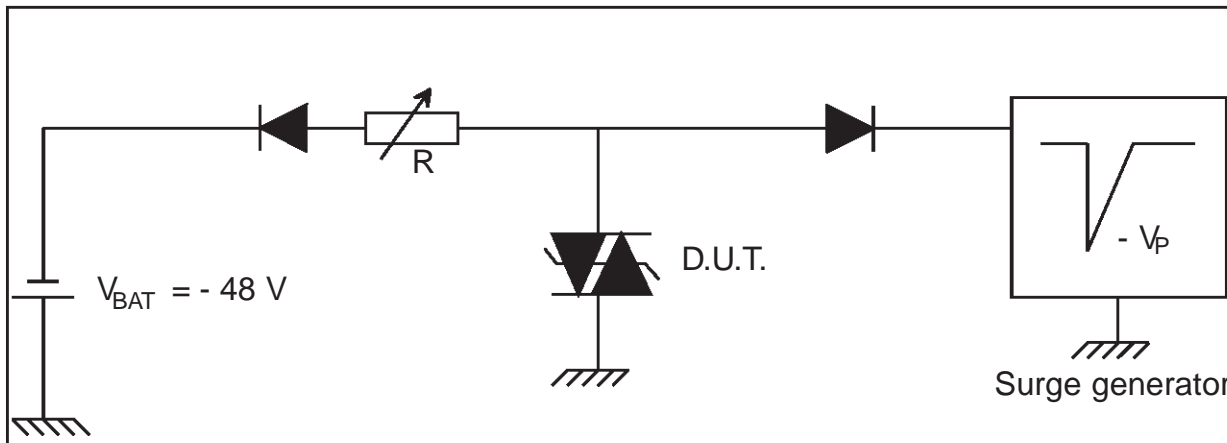

This is a GO-NOGO Test which allows to confirm the holding current (I_H) level in a functional test circuit.

TEST PROCEDURE :

- 1) Adjust the current level at the I_H value by short circuiting the AK of the D.U.T.
- 2) Fire the D.U.T with a surge Current : $I_{pp} = 10A$, $10/1000\mu s$.
- 3) The D.U.T will come back off-state within 50 ms max.

APPLICATION CIRCUIT

Typical line card protection concept

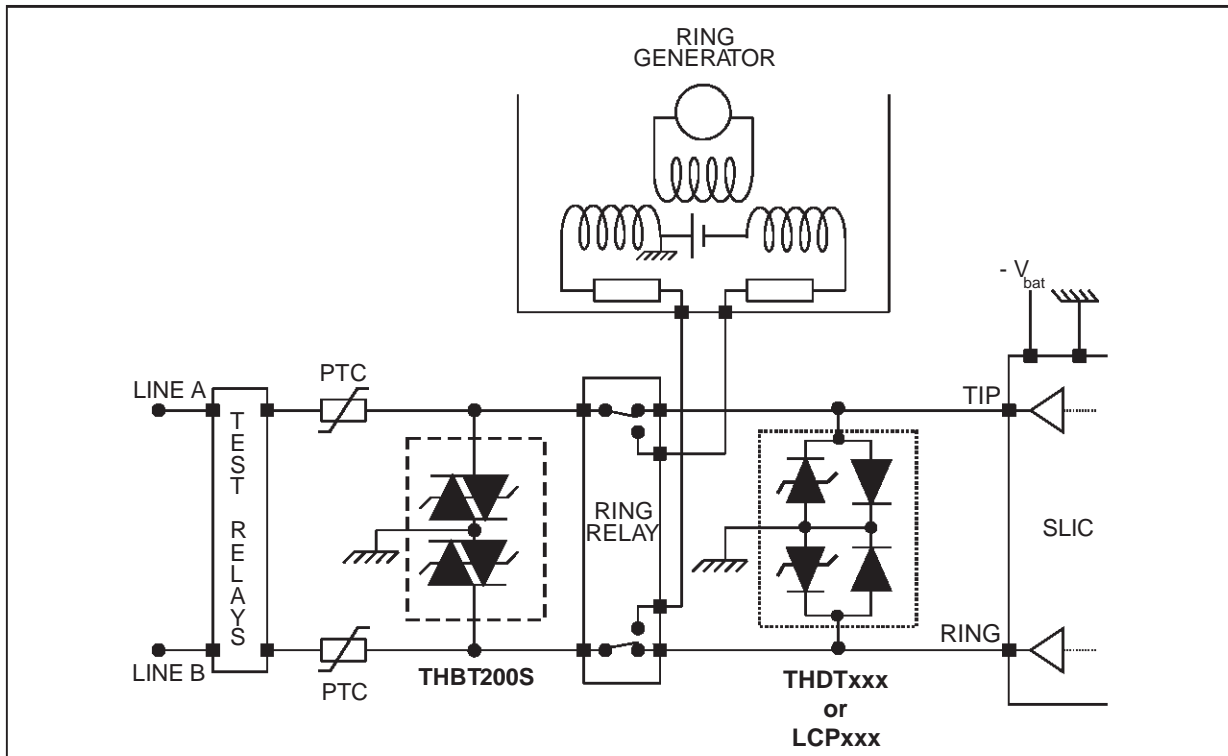

FUNCTIONAL DESCRIPTION

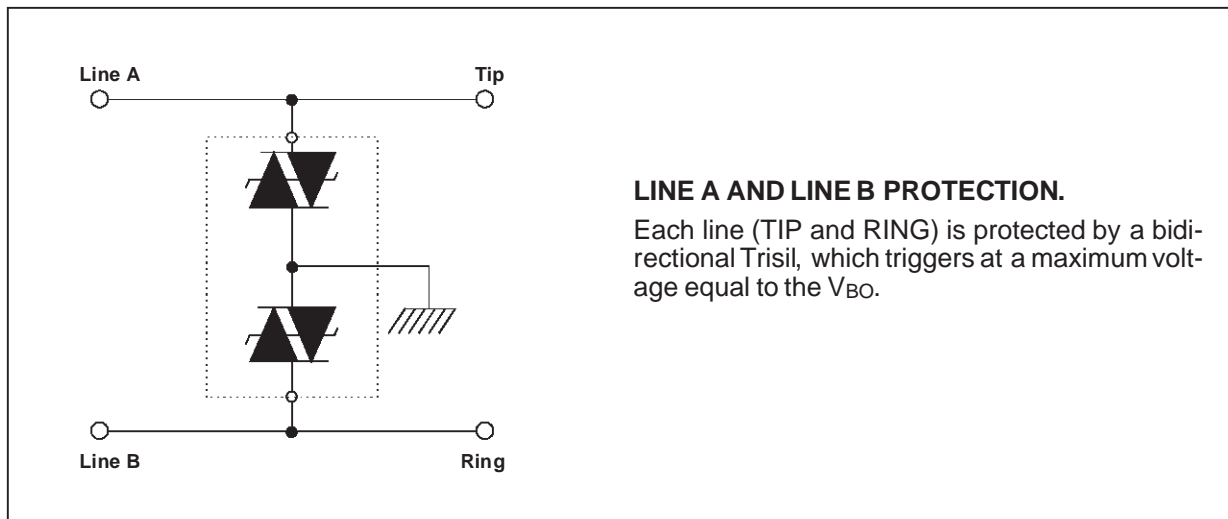

Fig. 1 : Relative variation of holding current versus junction temperature.

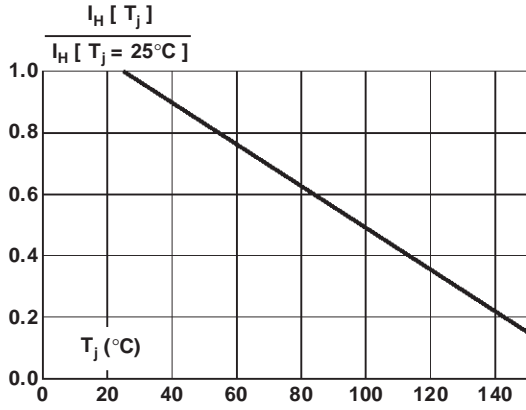

Fig. 2 : Surge peak current versus overload duration.

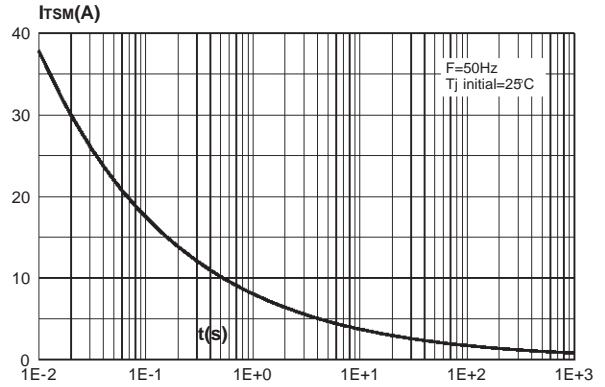

Fig. 3 : Peak on state voltage versus peak on state current (typical values).

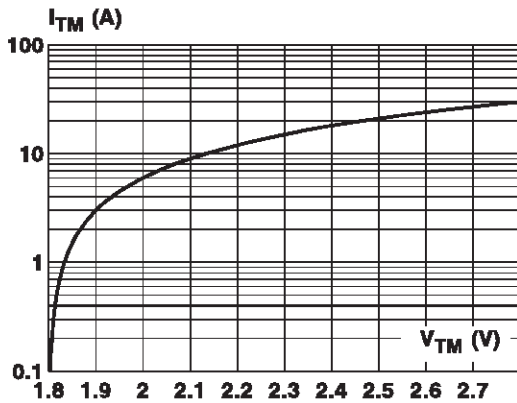
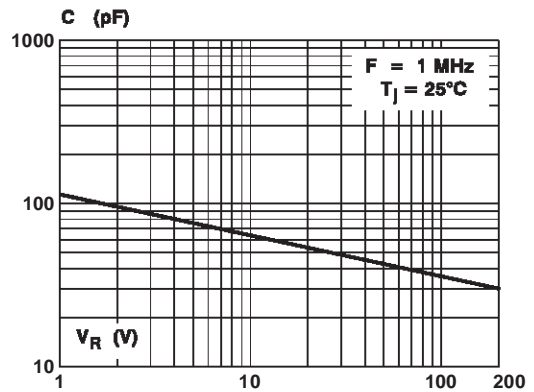
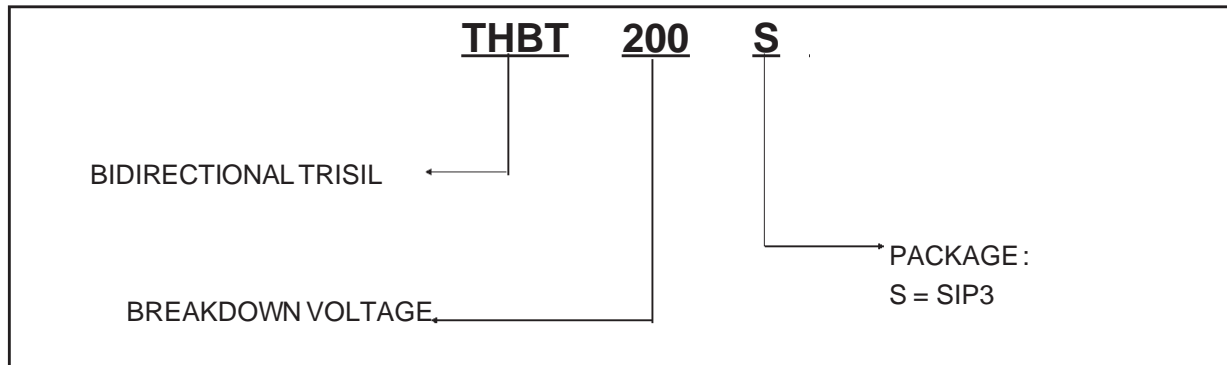

Fig. 4 : Capacitance versus reverse applied voltage (typical values).



ORDER CODE



MARKING :

Package	Types	Marking
SIP3	THBT200S	THBT200S

PACKAGE MECHANICAL DATA

SIP3 Plastic

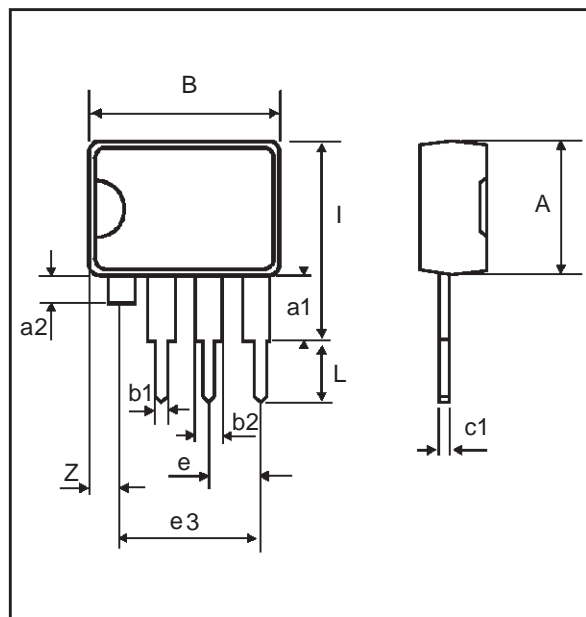

REF.	DIMENSIONS					
	Millimetres			Inches		
	Min.	Typ.	Max.	Min.	Typ.	Max.
A			7.10			0.280
a1	2.80			0.110		
a2	1.50		1.90	0.059		0.075
B			10.15			0.400
b1		0.50			0.020	
b2	1.35		1.75	0.053		0.069
c1	0.38		0.50	0.015		0.020
e		2.54			0.100	
e3		7.62			0.200	
I			10.50			0.413
L		3.30			0.130	
Z			1.50			0.059

Packaging: Products supplied in antistatic tubes.

Weight: 0.55g

Information furnished is believed to be accurate and reliable. However, SGS-THOMSON Microelectronics assumes no responsibility for the consequences of use of such information nor for any infringement of patents or other rights of third parties which may result from its use. No license is granted by implication or otherwise under any patent or patent rights of SGS-THOMSON Microelectronics. Specifications mentioned in this publication are subject to change without notice. This publication supersedes and replaces all information previously supplied. SGS-THOMSON Microelectronics products are not authorized for use as critical components in life support devices or systems without express written approval of SGS-THOMSON Microelectronics.

© 1998 SGS-THOMSON Microelectronics - Printed in Italy - All rights reserved.

SGS-THOMSON Microelectronics GROUP OF COMPANIES

Australia - Brazil - Canada - China - France - Germany - Italy - Japan - Korea - Malaysia - Malta - Morocco
The Netherlands - Singapore - Spain - Sweden - Switzerland - Taiwan - Thailand - United Kingdom - U.S.A.