

# THCS134

## I/O Spreader TSSOP28

### General Description

The THCS134 provides a function to serialize multiple parallel signals into single-ended serial line at least or to deserialize the data stream over single-ended serial line or single differential pair into multiple parallel signals.

This small number of transmission line simplifies system configuration and reduces system cost including cable width, connector size and pins and PCB layout area.

The THCS134 is offered in 8bit/16bit parallel IOs as host MPU interface. It can transfer 16bit independent parallel signals to remote side by only 1-line or 1-pair cable. Also, the THCS134 set as master device can control plural slave devices by transmitting and receiving data that is designated as a device address.

Transmitter, receiver or transceiver function can be selected by pins.

### Features

- No External Clock Required.
- 8bit/16bit Parallel IOs to MPU.
- Uni-directional/Bi-directional Mode Selectable
- Single-ended/Differential Mode (noise tolerant) Selectable
- AC Coupling Supported with Differential Mode
- Transmission Status Error Indicator Supported (Line Cut Detection and Packet Error Detection)
- Digital Filter Function.
- Power supply : 3.0 to 5.5V
- TSSOP 28-pin
- EU RoHS Compliant

### Block Diagram

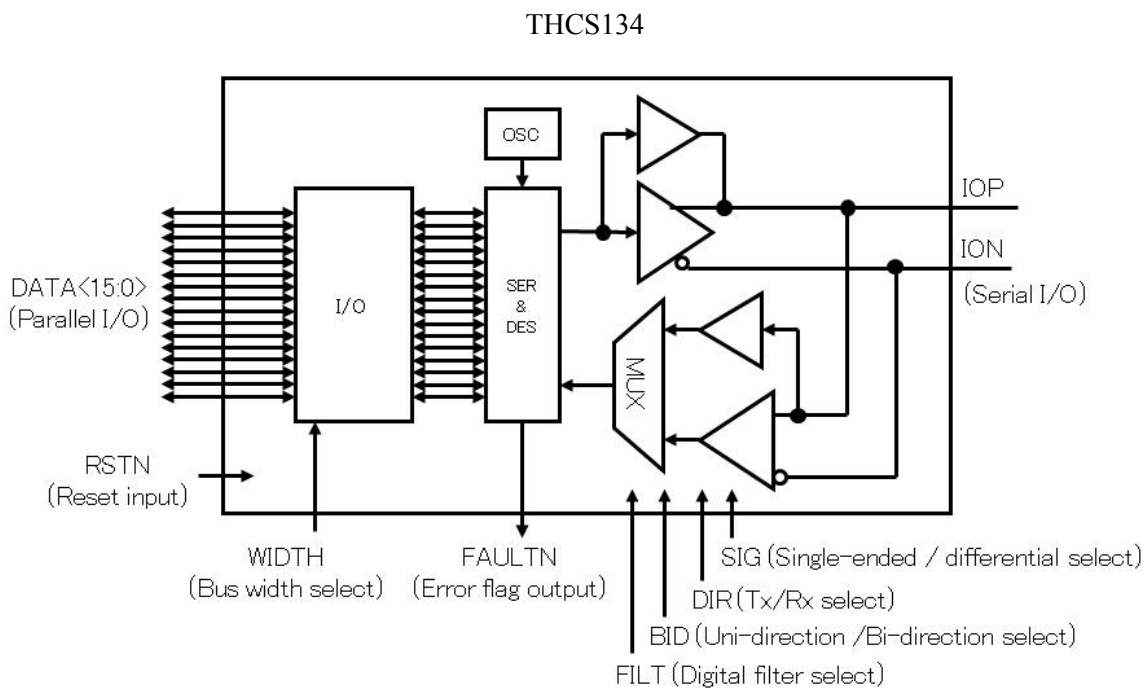

Pin Diagram

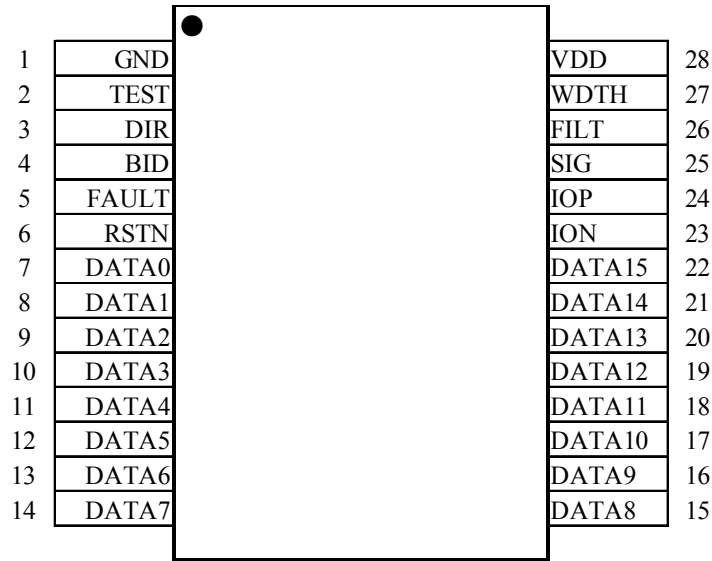

Pin Description

Pin No.	Pin Name	Internal Processing	Description
1	GND	-	Ground
2	TEST	Input, Pull-down	Test pin. Please connect to GND.
3	DIR	Input, Pull-down	Transmitter/receiver select Low : Transmitter (Uni-direction) / Master (Bi-direction) High : Receiver (Uni-direction) / Slave (Bi-direction)
4	BID	Input, Pull-down	Uni-direction/Bi-direction mode select Low : Uni-direction High : Bi-direction
5	FAULTN	Output, Open-drain	Transmitter status error indicator Low : Abnormal operation detected
6	RSTN	Input, Pull-down	Reset input Low : Reset High : Normal operation
7-22	DATA0-15	Input/Output, Pull-down	Parallel data I/O bit : 0-15 Refer to the tables of "Parallel I/O Pin Function"
23	ION	Input/Output	Serial data differential mode(-) I/O
24	IOP	Input/Output	Serial data CMOS/differential mode(+) I/O
25	SIG	Input, Pull-down	Serial data I/O mode select Low : CMOS High : Differential
26	FILT	Input, Pull-down	Digital filter enable pin Low : OFF High : ON
27	WIDTH	Input, Pull-down	Data bit width select Low : 8bit High : 16bit
28	VDD	-	Power Supply

**Absolute Maximum Rating**

Parameter	Condition	Min	Typ	Max	Unit
Power Supply Voltage VDD	-	-0.4	-	6	V
Digital Input Voltage (DATA0-DAT15,WIDTH,BID,FILT,DIR,SIG, RSTN)	-	-0.4	-	6	V
Open-drain Output Pin(FAULTN)	-	-0.4	-	6	V
Allowable Power Dissipation	Ta=25°C	-	-	2	W
Storage Temperature	-	-55	-	150	°C
Junction Temperature	-	-	-	125	°C

**Recommended Operating Condition**

Parameter	Condition	Min	Typ	Max	Unit
Power Supply Voltage VDD	-	3.0	-	5.5	V
Ambient Operating Temperature	-	-40	-	85	°C

**Electrical Characteristics DC Characteristics** (at VDD=5.0V, Ta=25°C, unless otherwise noted)

Parameter	Condition	Min	Typ	Max	Unit
Power Supply Current	Mode E LVDS mode (Note)	-	20	30	mA
UVLO Threshold Voltage (VDD Rising)	-	-	2.6	2.8	V
UVLO Hysteresis Voltage	-	-	0.15	-	V
Digital Input High-level Voltage (VIH)	-	0.7VDD	-	-	V
Digital Input Low level Voltage (VIL)	-	-	-	0.3VDD	V
Digital Input Leakage Current 1	-	-	-	+/-50	uA
Digital Input Hysteresis Voltage	-	-	0.11VDD	-	V
Digital Output High-level Voltage (VOH)	VDD=3.0V Tj=125°C IOH=-4mA	VDD-0.6	-	-	V
Digital Output High-level ON Resistance (RonH)	VDD=3.3V	-	56	-	Ω
	VDD=5.0V	-	46	-	Ω
Digital Output Low-level Voltage (VOL)	VDD=3.0V Tj=125 IOL=4mA	-	-	0.4	V
Digital Output Low-level ON Resistance (RonL)	VDD=3.3V	-	44	-	Ω
	VDD=5.0V	-	36	-	Ω
Open Drain Output Low-level Voltage	Iout=1mA FAULTN	-	-	0.4	V
LVDS Differential Input Voltage (VID)	IOP/ION	200	-	-	mV
LVDS Input Leakage Current	IOP/ION	-	-	+/-50	uA
LVDS Differential Output Voltage (VOD)	VDD=3.0V IOP/ION	350	-	-	mV
	VDD=5.0V IOP/ION	-	600	-	mV
	VDD=5.5V IOP/ION	-	-	750	mV
LVDS Output Common-mode Voltage (VOC)	IOP/ION	1.0	1.25	1.4	V
Pull-down Resistance	-	-	250	-	kΩ

Note: The power supply current is maximum in this condition.

LVDS Input Output Differential Voltage

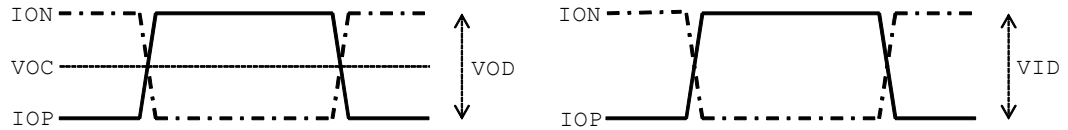

**Electrical Characteristics AC Characteristics (Reset Section)**

Mark	Parameter	Condition	Min	Typ	Max	Unit
tRST	Time from Reset (RSTN) Release to Valid Input	-	-	-	100 (Note)	us
tWRST	Reset (RSTN) Low Pulse Width	-	50	-	-	ns

Note : In AC coupling, tRST changes with the capacity to connect.

Timing Chart (Reset Section)

**Reset signal (RSTN)**

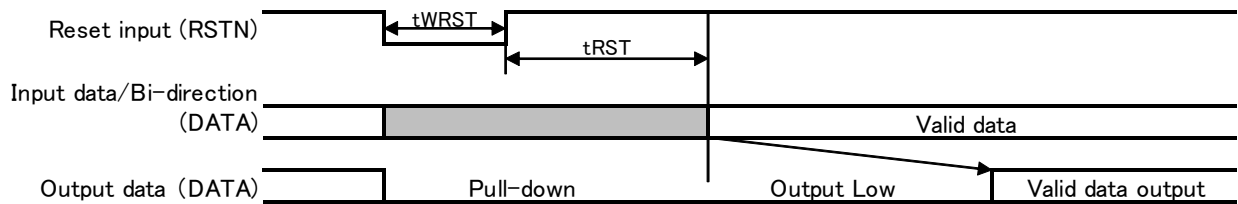

In the case of the mode F, output is controlled by signal of output enable (OEN\_L/OEN\_U), a pull-down state is continued until it sets signal of output enable to LOW.

**Electrical Characteristics AC Characteristics (Serial Communication)**

Mark	Item	Condition	Min	Typ	Max	Unit
fPSPLa	Serializer Input Sampling Frequency (Uni-direction)	BID=L	50	-	-	kHz
fPSPLb	Serializer Input Sampling Frequency (Bi-direction)	BID=H	30	-	-	kHz
tPSa	Time of Serializer Transmission (Uni-direction)	BID=L	-	-	18	us
tSPa	Deserializer Output Renewal Time (Uni-direction)	BID=L	-	-	2	us
tPSb	Time of Serializer Transmission (Bi-direction)	BID=H	-	-	14	us
tSPb	Deserializer Output Renewal Time (Bi-direction)	BID=H	-	-	2	us
fSTR	Serial Data Transmission Rate	-	-	2.5	-	MHz

Timing Chart (Uni-direction Mode)

Transmitter Mode

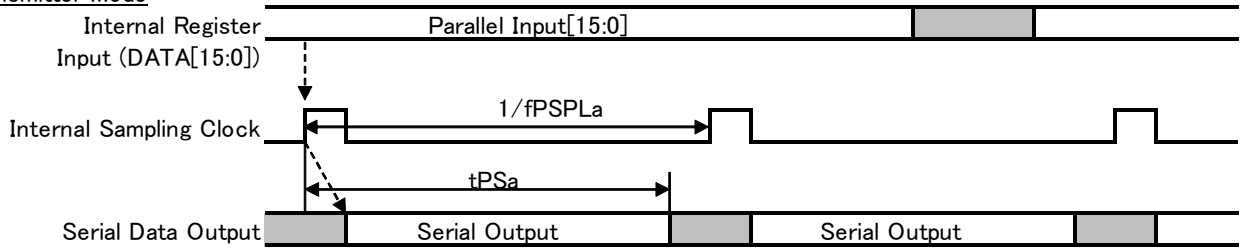

Receiver Mode

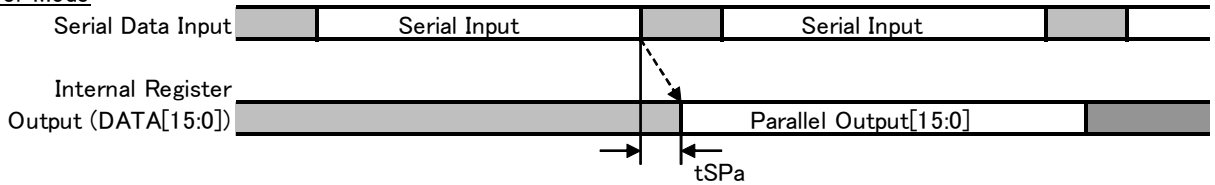

Timing Chart (Bi-direction Mode)

Master device

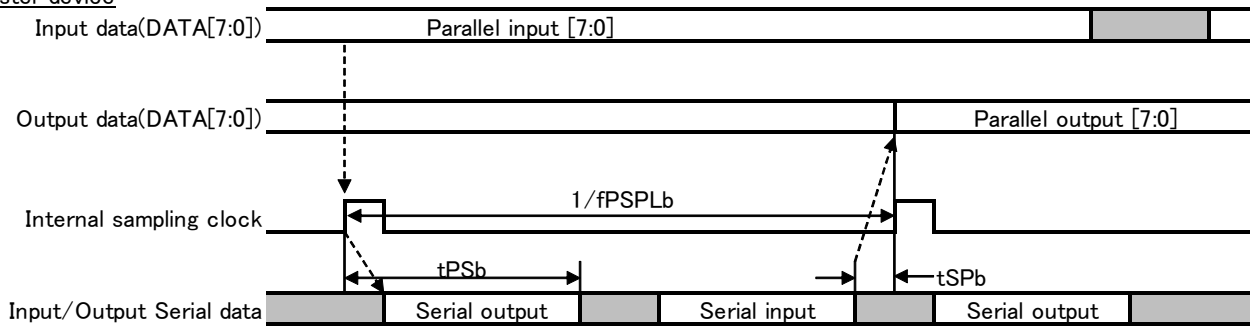

Slave device

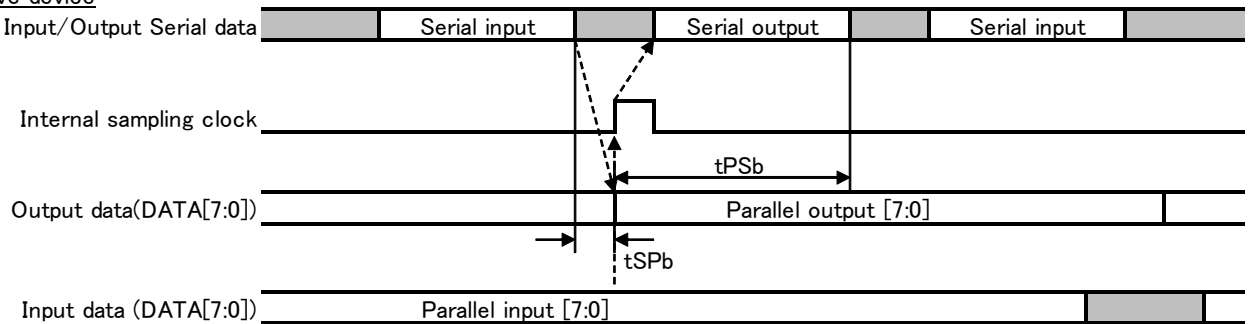

Electrical Characteristics AC Characteristics (Latch Enable, Output Enable)

Symbol	Parameter	Condition	Min	Typ	Max	Unit
tWLE	Latch Enable (LEN_U/LEN_L/LEN) Pulse Width	-	130	-	-	ns
tSULE	Latch Enable (LEN_U/LEN_L/LEN) Rise Edge Setup Time	-	133	-	-	ns
tHLE	Latch Enable (LEN_U/LEN_L/LEN) Rise Edge Hold Time	-	20	-	-	ns
tCLLEa	Latch Enable (LEN_U/LEN_L/LEN) Clearance1	-	100	-	-	ns
tCLLEb1	Latch Enable (LEN_U/LEN_L/LEN) Clearance2 (Uni-direction)	-	20	-	-	us
tCLLEb2	Latch Enable (LEN) Clearance2 (Bi-direction)	-	40	-	-	us
tWOE	Output Enable (OEN_U/OEN_L) Pulse Width	-	50	-	-	ns
tCLOE	Output Enable (OEN_U/OEN_L) Clearance	-	50	-	-	ns
tPZO	Output Enable (OEN_U/OEN_L) Delay Time	CL=25pF	-	-	50	ns
tPOZ	Output Disable (OEN_U/OEN_L) Delay Time	CL=25pF	-	-	38	ns

Timing Chart (Latch Enable, Output Enable)

8bit Input + Latch Enable

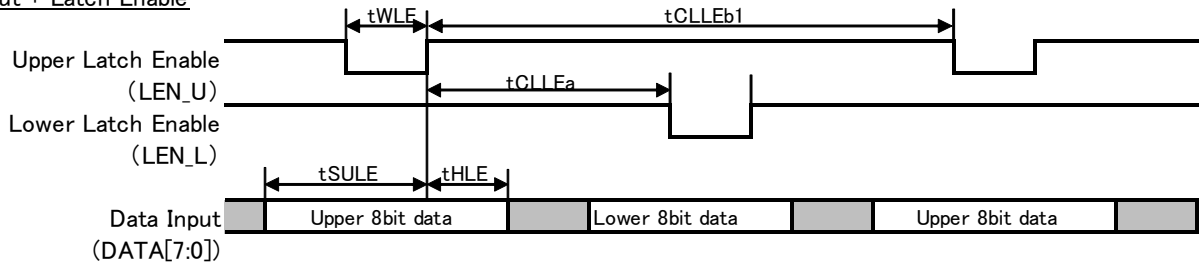

8bit Output+ Output Enable

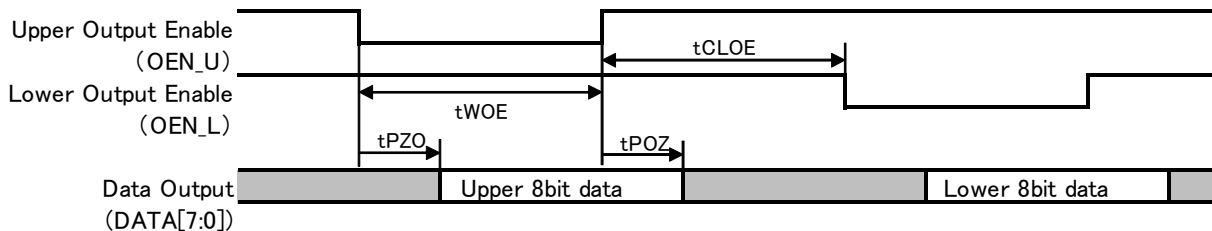

When receiving new incoming data during OEN\_U or OEN\_L = Low, output data is updated to this new data.

8bit Input/Output + Latch enable • Output enable

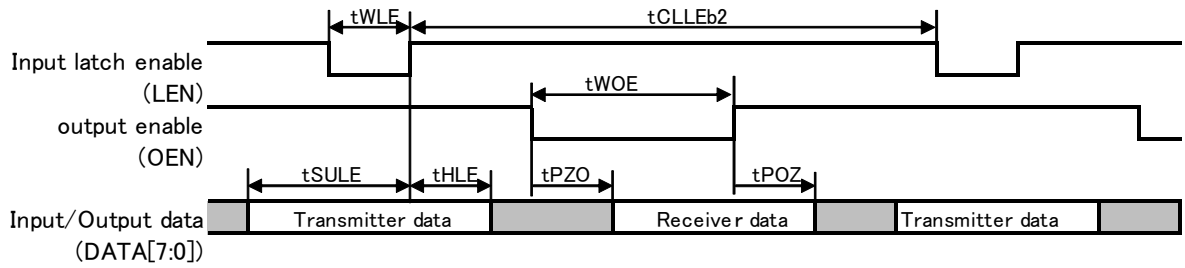

When receiving new incoming data during OEN = Low, output data is updated to this new data

Functional Description

• Functional Description List for Mode Pin

Mode Name	Pin Name					Operating Mode
	WIDTH	BID	DIR	DATA10	DATA11	
A	H	L	L	-	-	16bit / Bi-direction / Transmitter
B			H	-	-	16bit / Bi-direction / Receiver
C		H	L	-	-	8bit / Bi-direction / Transmitter • Receiver Master
D			H	-	-	8bit / Bi-direction / Transmitter • Receiver Slave
E	L	L	L	L	L	8bit (Upper • Lower) / Uni-direction / Transmitter
F			H			8bit (Upper • Lower) / Uni-direction / Receiver
G		H	L			8bit (Upper • Lower) / Bi-direction / Transmitter • Receiver Master
H		L	H			8bit / Uni-direction / Transmitter Address Appointment
I		H	H			-



• Mode Connectable Table

Mode Name	A	B	C	D	E	F	G	H	I	Operating Mode
A		v				v		v		16bit / Uni-direction / Transmitter
B	v				v		v			16bit / Uni-direction / Receiver
C				v					v	8bit / Bi-direction / Transmitter • Receiver Master
D			v				v			8bit / Bi-direction / Transmitter • Receiver Master
E		v				v		v		8bit (Upper • Lower) / Uni-direction / Transmitter
F	v				v					8bit (Upper • Lower) / Uni-direction / Receiver
G		v		v					v	8bit (Upper • Lower) / Bi-direction / Transmitter • Receiver Master
H	v				v					8bit / Uni-direction / Receiver Address Appointment
I			v				v			7-bit / Bi-direction / Transmitter Address Appointment Slave

• 「v」 mark indicates a possible connection mode.

• Parallel I/O Pin Function (Mode A, B, C, D)

WIDTH	High (16bit)							
	Low (Uni-direction)		Low (Uni-direction)		High (Bi-direction)		High (Bi-direction)	
DIR	Low (Transmitter)		High (Receiver)		Low (Master)		High (Slave)	
Mode	A		B		C		D	
	I/O	Function Name	I/O	Function Name	I/O	Function Name	I/O	Function Name
DATA0	I	DIN0	O	DOUT0	I	DIN0	I	DIN0
DATA1	I	DIN1	O	DOUT1	I	DIN1	I	DIN1
DATA2	I	DIN2	O	DOUT2	I	DIN2	I	DIN2
DATA3	I	DIN3	O	DOUT3	I	DIN3	I	DIN3
DATA4	I	DIN4	O	DOUT4	I	DIN4	I	DIN4
DATA5	I	DIN5	O	DOUT5	I	DIN5	I	DIN5
DATA6	I	DIN6	O	DOUT6	I	DIN6	I	DIN6
DATA7	I	DIN7	O	DOUT7	I	DIN7	I	DIN7
DATA8	I	DIN8	O	DOUT8	O	DOUT0	O	DOUT0
DATA9	I	DIN9	O	DOUT9	O	DOUT1	O	DOUT1
DATA10	I	DIN10	O	DOUT10	O	DOUT2	O	DOUT2
DATA11	I	DIN11	O	DOUT11	O	DOUT3	O	DOUT3
DATA12	I	DIN12	O	DOUT12	O	DOUT4	O	DOUT4
DATA13	I	DIN13	O	DOUT13	O	DOUT5	O	DOUT5
DATA14	I	DIN14	O	DOUT14	O	DOUT6	O	DOUT6
DATA15	I	DIN15	O	DOUT15	O	DOUT7	O	DOUT7

Connection Examples (Mode A, B, C, D)

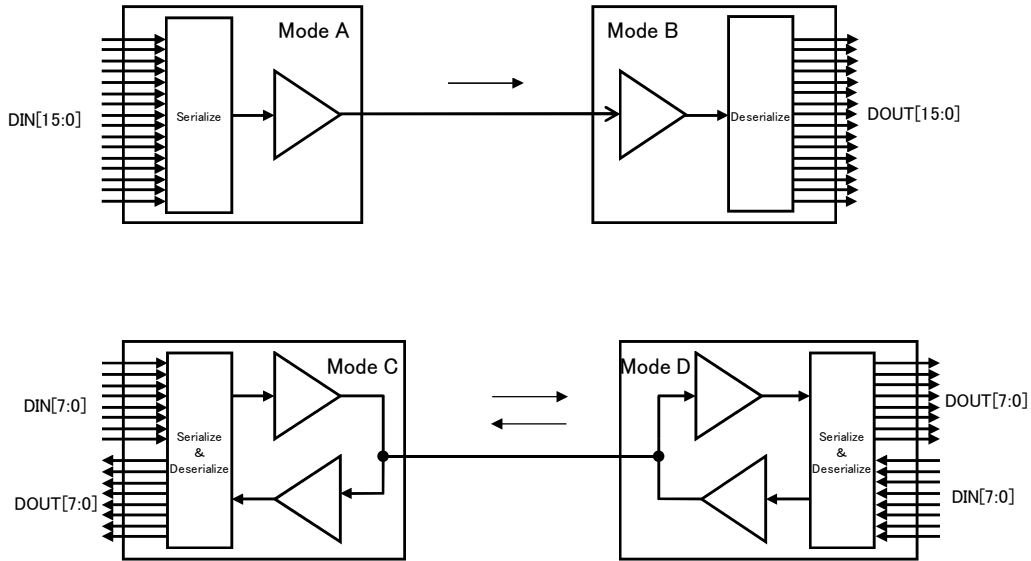

Parallel I/O Pin Function (Mode E, F, G)

WIDTH	Low (8bit Upper·Lower)					
BID	Low (Uni-direction)		Low (Uni-direction)		High (Bi-direction)	
DIR	Low (Transmitter)		High (Transmitter)		Low (Master)	
Mode	E		F		G	
	I/O	Function Name	I/O	Function Name	I/O	Function Name
DATA0	I	DIN0	O	DOUT0	IO	DIO0
DATA1	-	-	-	-	-	-
DATA2	I	DIN1	O	DOUT1	IO	DIO1
DATA3	-	-	-	-	-	-
DATA4	I	DIN2	O	DOUT2	IO	DIO2
DATA5	-	-	-	-	-	-
DATA6	I	DIN3	O	DOUT3	IO	DIO3
DATA7	-	-	-	-	-	-
DATA8	I	LEN_L	I	OEN_L	I	LEN
DATA9	I	LEN_U	I	OEN_U	I	OEN
DATA10	I	Low	I	Low	I	Low
DATA11	I	Low	I	Low	I	Low
DATA12	I	DIN4	O	DOUT4	IO	DIO4
DATA13	I	DIN5	O	DOUT5	IO	DIO5
DATA14	I	DIN6	O	DOUT6	IO	DIO6
DATA15	I	DIN7	O	DOUT7	IO	DIO7

\*Non-functional pins marked as “-” are pulled down by 250kΩ internally

Connection Example (Mode E, F, G)

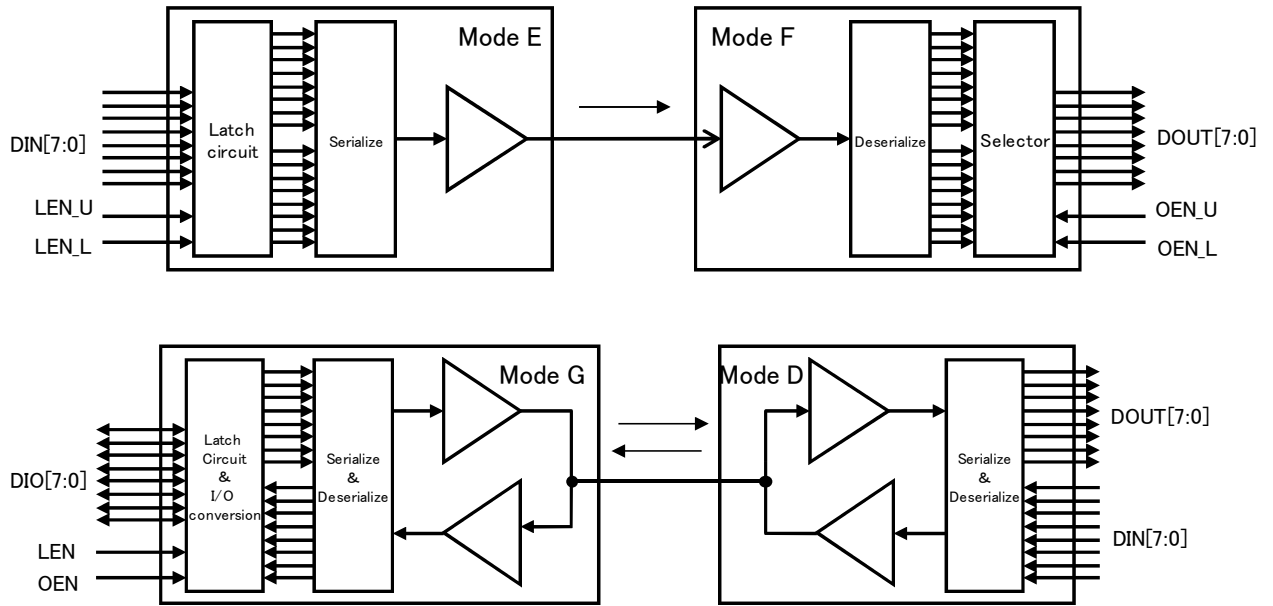

• Latch Enable, Output Enable Truth Table

Mode E

LEN_U	LEN_L	Latch Enable Input
L	L	Lower 8bit is transmitted by sampling frequency (8bit through mode)
↑	H	Upper 8bit input latch
H	↑	Lower 8bit input latch and 16bit data reception
H	H	Keep data

The rising edge of LEN\_L is the trigger for sampling of upper and lower data.

Mode F

OEN_U	OEN_L	Output Enable Input
L	L	Output disable (DATA pins are pulled down by 250kΩ internally)
L	H	Upper 8bit Output enable
H	L	Lower 8bit Output enable
H	H	Output disable (DATA pins are pulled down by 250kΩ internally)

Mode G

LEN	OEN	Latch Enable, Output Enable Input
L	L	Prohibition
↑	H	8bit Input Latch
H	L	8bit Output enable
H	H	Output disable (DATA pins are pulled down by 250kΩ internally)

• Parallel I/O Pin Function (Mode H, I)

WIDTH	Low (8 / 7bit Upper•Lower)			
	Low (Uni-direction)		High (Bi-direction)	
DIR	High (Reception)		High (Reception)	
Mode	H		I	
	I/O	Function Name	I/O	Function Name
DATA0	O	DOUT0	I	DIN0
DATA1	O	DOUT1	I	DIN1
DATA2	O	DOUT2	I	DIN2
DATA3	O	DOUT3	I	DIN3
DATA4	O	DOUT4	I	DIN4
DATA5	O	DOUT5	I	DIN5
DATA6	O	DOUT6	I	DIN6
DATA7	O	DOUT7	I	Low
DATA8	-	-	-	-
DATA9	-	-	-	-
DATA10	-	-	-	-
DATA11	I	High	I	High
DATA12	I	ADDR0	I	ADDR0
DATA13	I	ADDR1	I	ADDR1
DATA14	I	ADDR2	I	ADDR2
DATA15	I	ADDR3	I	ADDR3

\*Non-functional pins marked as “-” are pulled down by 250kΩ internally

Connection Examples (Mode H, I)

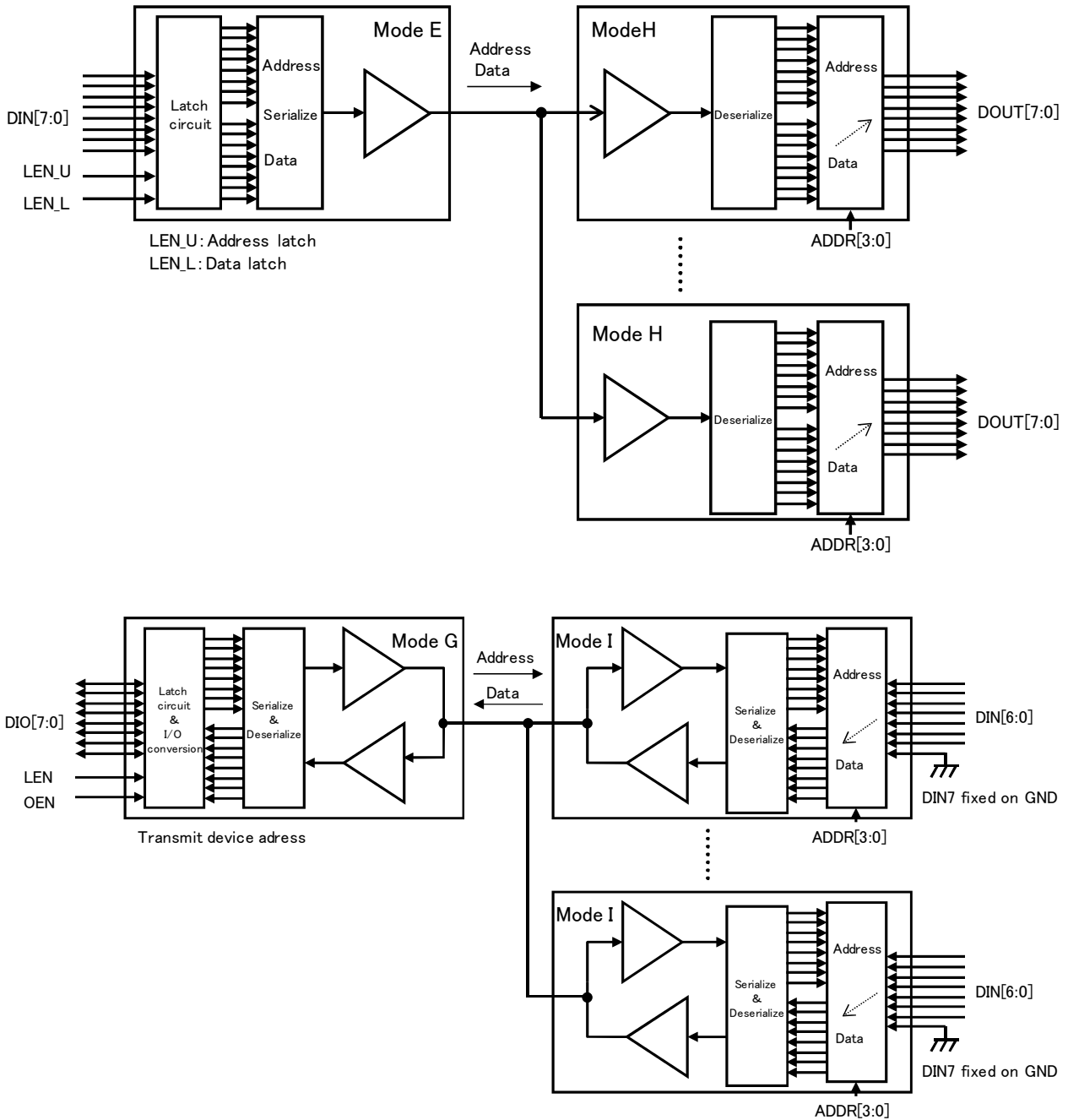

Device Address (Mode H, I)

- As to transmitter device, set device address into upper 8bit and data into lower 8bit. The device address is selectable out of 15 addresses( 10000001b~10001111b(81h~8Fh))
- The upper 4 bits of receiver device address is fixed as 1000b, and lower 4 bits are set by  $ADDR[3:0]$  pins.
- Mode H offers to output the same data from all devices. Set to broadcast device address as 10000000b (80h). Mode I is not able to handle Broadcast.

- Function Setup for Serial I/O Pins

IOP and ION pins are set as 1 line CMOS I/O or 2-lane LVDS I/O with a SIG pin.

Pin Setup	Pin Function		Description
	IOP	ION	
L	CMOS I/O	*	CMOS I/O
H	Differential mode I/O+	Differential mode I/O	Differential mode I/O

\* : Please keep pin being opened(No connection)

- Function of Transmission Status Error Indicator, FAULTN (Receiver mode)

FAULTN is the output pin. When the protocol of received data is not correct or serial data more than 50usec (typ) is not received, FAULTN pin will be changed into low level. The received data is canceled when a FAULTN pin outputs Low. When normal serial data is received, a FAULTN pin outputs High in case of pulled up externally.

- Digital Filter Function

When FILT pin is set to high level, the digital filter function is active. If the receiver matches the 3 sampling frequency content with the deserialized parallel data, it is updated as the correct data.

- Writing and Reading of Parallel Data by Serial Communication

The THCS134 is able to write and read data by 3-wire serial I/F on 16bit register.

### **Electrical Characteristic AC Characteristics (3-wire Serial I/O Unit)**

Mark	Parameter	Condition	Min	Typ	Max	Unit
fSCK	SCK Frequency	-	-	-	10	MHz
tCH	SCK High period	-	50	-	-	ns
tCL	SCK Low period	-	50	-	-	ns
tDVCH	SI Setup time	-	10	-	-	ns
tCHDX	SI Hold time	-	15	-	-	ns
tCHSL	CSN Not Active Hold time	-	10	-	-	ns
tSLCH	CSN Active Setup time	-	200	-	-	ns
tCHSH	CSN Active Hold time	-	50	-	-	ns
tSHCH	CSN Not Active Set up time	-	50	-	-	ns
tSHSL	CSN Not Active period	-	2	-	-	us
tSLSO	Delay time From CSN Fall to SO Output	CL=25pF	-	-	190	ns
tCLSO	Delay time From SCK Fall to SO Output	CL=25pF	-	-	40	ns

Timing Chart (3-wire Serial I/O Unit)

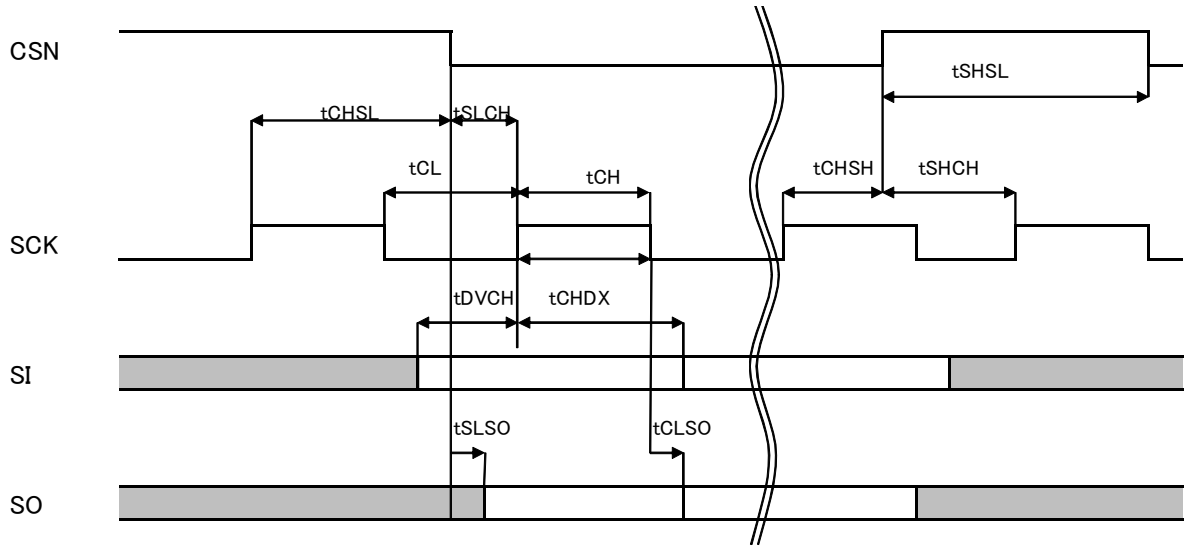

Function Description

Mode Pin Function Setting List

Mode Name	Pin Name				Operating Mode
	WIDTH	BID	DIR	Etc	
A serial	L	L	L	DATA10:H DATA11:L	Serial / Uni-direction / Transmitter
B serial		L	H		Serial / Uni-direction / Receiver
C serial		H	L		Serial / Bi-direction / Master

Parallel I/O Pin Function (Mode A serial, B serial, C serial)

WIDTH	Low (3 lines serial)					
BID	Low (Uni-direction)		Low (Uni-direction)		High (Bi-direction)	
DIR	Low (Transmitter)		High (Transmitter)		Low (Master)	
Mode	A Serial		B Serial		C Serial	
	I/O	Function name	I/O	Function name	I/O	Function name
DATA0	I	CSN	I	CSN	I	CSN
DATA1	I	SCK	I	SCK	I	SCK
DATA2	I	SI	-	-	I	SI
DATA3	-	-	O	SO	O	SO
DATA4	-	-	-	-	-	-
DATA5	-	-	-	-	-	-
DATA6	-	-	-	-	-	-
DATA7	-	-	-	-	-	-
DATA8	-	-	-	-	-	-
DATA9	-	-	-	-	-	-
DATA10	I	High	I	High	I	High
DATA11	I	Low	I	Low	I	Low
DATA12	-	-	-	-	-	-
DATA13	-	-	-	-	-	-
DATA14	-	-	-	-	-	-
DATA15	-	-	-	-	-	-

\* Unnamed pin is pulled down by 250kΩ internally.

Connection Examples (Mode A serial, B serial, C serial)

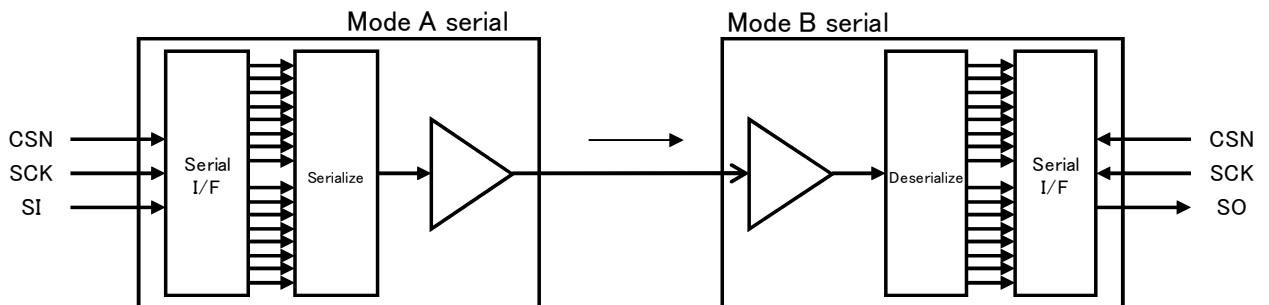



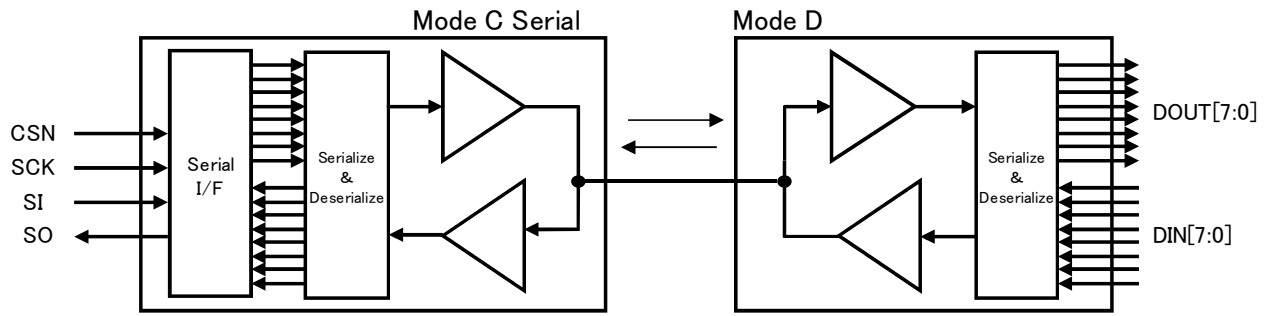

**Package**

**TSSOP-28pin**

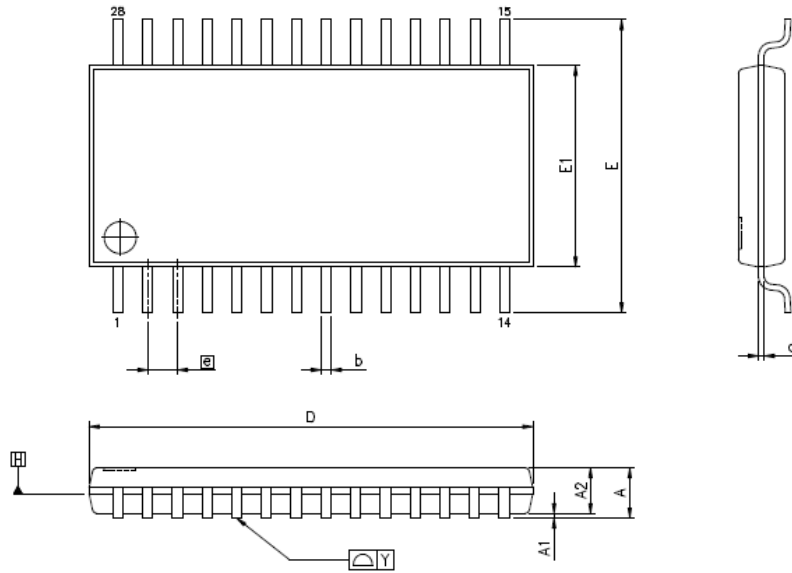

SYMBOLS	MIN.	NOM	MAX.
A	-	-	1.20
A1	0.00	-	0.15
A2	0.80	1.00	1.05
b	0.19	-	0.30
c	0.09	-	0.20
D	9.60	9.70	9.80
E1	4.30	4.40	4.50
E	6.40 BSC		
e	0.65 BSC		
L1	1.00 REF		
L1	0.45	0.60	0.75
S	0.20	-	-
θ	0°	-	8°
Y	0.10		

Unit: mm

---

### Notices and Requests

1. The product specifications described in this material are subject to change without prior notice.
2. The circuit diagrams described in this material are examples of the application which may not always apply to the customer's design. We are not responsible for possible errors and omissions in this material. Please note if errors or omissions should be found in this material, we may not be able to correct them immediately.
3. This material contains our copyright, know-how or other proprietary. Copying or disclosing to third parties the contents of this material without our prior permission is prohibited.
4. Note that if infringement of any third party's industrial ownership should occur by using this product, we will be exempted from the responsibility unless it directly relates to the production process or functions of the product.
5. (1) Application of this product is intended for and limited to the following applications: audio-video device, office automation device, communication device, consumer electronics, smartphone, feature phone, and amusement machine device. This product must not be used for applications that require extremely high-reliability/safety such as aerospace device, traffic device, transportation device, nuclear power control device, combustion chamber device, medical device related to critical care, or any kind of safety device.  
(2) This product is not intended to be used as an automotive part, unless the product is specified as a product conforming to the demands and specifications of ISO/TS16949 ("the Specified Product") in this data sheet. THine Electronics, Inc. ("THine") accepts no liability whatsoever for any product other than the Specified Product for it not conforming to the aforementioned demands and specifications.  
(3) THine accepts liability for demands and specifications of the Specified Product only to the extent that the user and THine have been previously and explicitly agreed to each other.
6. Despite our utmost efforts to improve the quality and reliability of the product, faults will occur with a certain small probability, which is inevitable to a semi-conductor product. Therefore, you are encouraged to have sufficiently redundant or error preventive design applied to the use of the product so as not to have our product cause any social or public damage.
7. Please note that this product is not designed to be radiation-proof.
8. Customers are asked, if required, to judge by themselves if this product falls under the category of strategic goods under the Foreign Exchange and Foreign Trade Control Law.
9. The product or peripheral parts may be damaged by a surge in voltage over the absolute maximum ratings or malfunction, if pins of the product are shorted by such as foreign substance. The damages may cause a smoking and ignition. Therefore, you are encouraged to implement safety measures by adding protection devices, such as fuses.

***THine Electronics, Inc.***

sales@thine.co.jp