

FEATURES

- Output Current up to 300mA
- MLCC, Aluminum electrolytic capacitor applicable
- Three Terminal Adjustable(ADJ) or Fixed 1.2V, 1.5V, 1.8V, 2.5V, 3.3V, 5.0V
- Line Regulation typically at 0.1% max.
- Load Regulation typically at 0.2% max.
- Internal Current and Terminal Protection
- Surface Mount Package SOT-23
- Moisture Sensitivity Level 3

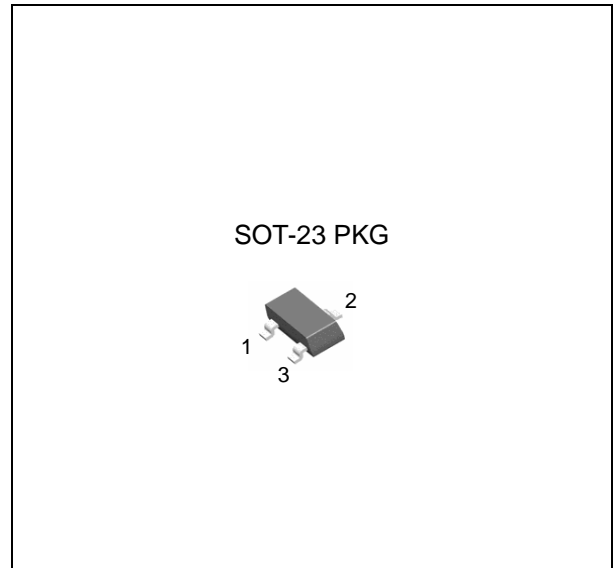

APPLICATION

- Active SCSI Terminators
- Portable/ Plan Top/ Notebook Computers
- High Efficiency Linear Regulators
- SMPS Post Regulators
- Mother B/D Clock Supplies
- Disk Drives
- Battery Chargers

ORDERING INFORMATION

Device	Package
TJ1117GSF-ADJ	SOT-23-3L
TJ1117GSF-X.X	

X.X = Output Voltage = 1.2V, 1.5V, 1.8V, 2.5V, 3.3V, 5.0V

DESCRIPTION

The TJ1117 is a low power positive-voltage regulator designed. This device is an excellent choice for use in battery-powered applications, as active terminators for the SCSI bus, and portable computers. The TJ1117 features low quiescent current and low dropout voltage of 1.2V at a full load and lower as output current decreases. TJ1117 is available as an adjustable or fixed 1.2V, 1.5V, 1.8V, 2.5V, 3.3V, and 5.0V. The TJ1117 is offered in a 3-pin surface mount package SOT-23. The output capacitor is needed for output stability of TJ1117 as required by most of the other regulator circuits.

Absolute Maximum Ratings

($T_A = 25^\circ\text{C}$, unless otherwise specified)

CHARACTERISTIC	SYMBOL	MIN.	MAX.	UNIT
DC Input Voltage	V_{IN}	-	20	V
Lead Temperature (Soldering, 5 seconds)	T_{SOL}	-	260	$^\circ\text{C}$
Operating Junction Temperature Range	T_{OPR}	-40	125	$^\circ\text{C}$
Storage Temperature Range	T_{STG}	-65	150	$^\circ\text{C}$

Ordering Information

V _{OUT}	Package	Order No.	Supplied As	Status
ADJ	SOT-23	TJ1117GSF-ADJ	Reel	Active
1.2V	SOT-23	TJ1117GSF-1.2	Reel	Contact us
1.5V	SOT-23	TJ1117GSF-1.5	Reel	Contact us
1.8V	SOT-23	TJ1117GSF-1.8	Reel	Contact us
2.5V	SOT-23	TJ1117GSF-2.5	Reel	Contact us
3.3V	SOT-23	TJ1117GSF-3.3	Reel	Active
5.0V	SOT-23	TJ1117GSF-5.0	Reel	Contact us

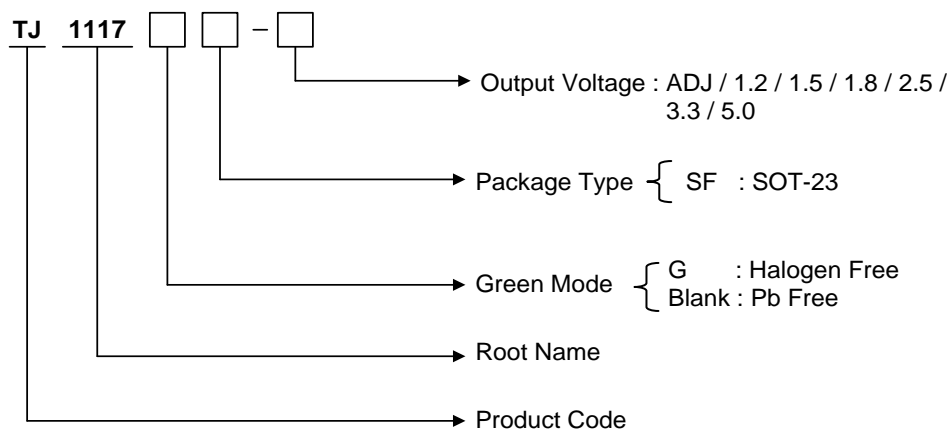

PIN CONFIGURATION

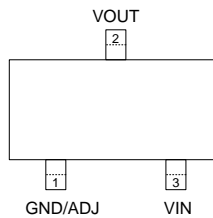

SOT-23

PIN DESCRIPTION

Pin No.	SOT-23	
	Name	Function
1	ADJ/GND	Adjustable / Ground
2	V _{OUT}	Output Voltage
3	V _{IN}	Input Voltage

Typical Application Circuit

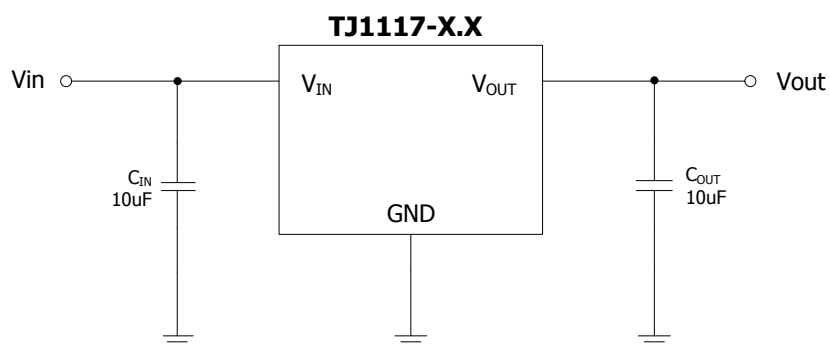

ELECTRICAL CHARACTERISTICS

For ADJ Output Voltage

($T_A=25^\circ\text{C}$, $C_{IN} = C_O = 10\mu\text{F}$ unless otherwise specified)

Symbol	Parameters	Condition	Min.	Typ.	Max.	Unit
V_{REF}	Reference Voltage	$V_{IN}=5\text{V}$, $I_O=10\text{mA}$	1.238	1.250	1.262	V
V_{REF}	Reference Voltage	$I_O = 10\text{mA}$ to 300mA , $V_{IN} - V_{REF} = 1.5\text{V}$ to 13.75V ($T_J = 0 \sim 125^\circ\text{C}$)	1.219		1.281	V
ΔV_{LINE}	Line Regulation	$I_O = 10\text{mA}$, $V_{IN} - V_{REF} = 1.5\text{V}$ to 12V		0.1	0.2	%
ΔV_{LOAD}	Load Regulation	$I_O = 10\text{mA}$ to 300mA , $V_{IN} - V_{REF} = 2\text{V}$		0.2	0.4	%
V_{IN}	Operating Input Voltage				12	V
I_{ADJ}	Adjustment pin Current	$V_{IN} - V_{REF} = 1.5\text{V}$ to 12V , $I_O = 100\text{mA}$		35	120	μA
ΔI_{ADJ}	Adjustment Pin Current Change	$V_{IN} - V_{REF} = 1.5\text{V}$ to 12V , $I_O = 100\text{mA}$ to 300mA		0.5	5	μA
$I_{O(MIN)}$	Minimum Load Current	$V_{IN}=5\text{V}$, $V_{REF}=0\text{V}$		5	10	mA
I_O	Current Limit	$V_{IN} - V_{REF} = 5\text{V}$	1000	1250	1600	mA
ϵ_N	Output Noise(% V_O)	$B = 10\text{Hz}$ to 10kHz , $T_J = 25^\circ\text{C}$		0.003		%
SVR	Supply Voltage Rejection	$I_O = 300\text{mA}$, $f = 120\text{Hz}$, $V_{IN} - V_{REF} = 3\text{V}$, $V_{RIPPLE} = 1\text{V}_{PP}$	60	75		dB

For 1.2V Output Voltage

($T_A=25^\circ\text{C}$, $C_{IN} = C_O = 10\mu\text{F}$ unless otherwise specified)

Symbol	Parameters	Condition	Min.	Typ.	Max.	Unit
V_O	Output Voltage	$V_{IN} = 2.7\text{V}$, $I_O = 10\text{mA}$	1.176	1.200	1.224	V
V_O	Output Voltage	$V_{IN} = 2.7\text{V}$ to 12V , $I_O = 0\text{mA}$ to 300mA ($T_J = 0 \sim 125^\circ\text{C}$)	1.152		1.248	V
ΔV_{LINE}	Line Regulation	$I_O = 0\text{mA}$, $V_{IN} = 2.7\text{V}$ to 12V		0.1	0.2	%
ΔV_{LOAD}	Load Regulation	$I_O = 10\text{mA}$ to 300mA , $V_{IN} = 3.2\text{V}$		0.2	0.4	%
V_{IN}	Operating Input Voltage				12	V
I_D	Quiescent Current	$V_{IN} - V_O = 5\text{V}$		5	10	mA
I_O	Current Limit	$V_{IN} - V_O = 5\text{V}$	1000	1250	1600	mA
ϵ_N	Output Noise(% V_O)	$B = 10\text{Hz}$ to 10kHz , $T_J = 25^\circ\text{C}$		0.003		%
SVR	Supply Voltage Rejection	$I_O = 300\text{mA}$, $f = 120\text{Hz}$, $V_{IN} - V_O = 1.5\text{V}$, $V_{RIPPLE} = 1\text{V}_{PP}$	60	75		dB

300mA L.D.O VOLTAGE REGULATOR

TJ1117GSF

For 1.5V Output Voltage

($T_A=25^{\circ}\text{C}$, $C_{IN} = C_O = 10\mu\text{F}$ unless otherwise specified)

Symbol	Parameters	Condition	Min.	Typ.	Max.	Unit
V_O	Output Voltage	$V_{IN} = 3.0\text{V}$, $I_O = 10\text{mA}$	1.485	1.5	1.515	V
V_O	Output Voltage	$V_{IN} = 3.0\text{V}$ to 12V , $I_O = 0\text{mA}$ to 300mA ($T_J = 0 \sim 125^{\circ}\text{C}$)	1.470		1.530	V
ΔV_{LINE}	Line Regulation	$I_O = 0\text{mA}$, $V_{IN} = 3.0\text{V}$ to 12V		0.1	0.2	%
ΔV_{LOAD}	Load Regulation	$I_O = 0\text{mA}$ to 300mA , $V_{IN} = 3.5\text{V}$		0.2	0.4	%
V_{IN}	Operating Input Voltage				12	V
I_D	Quiescent Current	$V_{IN} - V_O = 5\text{V}$		5	10	mA
I_O	Current Limit	$V_{IN} - V_O = 5\text{V}$	1000	1250	1600	mA
ϵ_N	Output Noise(% V_O)	$B = 10\text{Hz}$ to 10kHz , $T_J = 25^{\circ}\text{C}$		100		μV
SVR	Supply Voltage Rejection	$I_O = 300\text{mA}$, $f = 120\text{Hz}$, $V_{IN} - V_O = 3\text{V}$, $V_{RIPPLE} = 1\text{V}_{PP}$	60	75		dB

For 1.8V Output Voltage

($T_A=25^{\circ}\text{C}$, $C_{IN} = C_O = 10\mu\text{F}$ unless otherwise specified)

Symbol	Parameters	Condition	Min.	Typ.	Max.	Unit
V_O	Output Voltage	$V_{IN} = 3.3\text{V}$, $I_O = 10\text{mA}$	1.782	1.8	1.818	V
V_O	Output Voltage	$V_{IN} = 3.3\text{V}$ to 12V , $I_O = 0\text{mA}$ to 300mA ($T_J = 0 \sim 125^{\circ}\text{C}$)	1.764		1.836	V
ΔV_{LINE}	Line Regulation	$I_O = 0\text{mA}$, $V_{IN} = 3.3\text{V}$ to 12V		0.1	0.2	%
ΔV_{LOAD}	Load Regulation	$I_O = 0\text{mA}$ to 300mA , $V_{IN} = 3.8\text{V}$		0.2	0.4	%
V_{IN}	Operating Input Voltage				12	V
I_D	Quiescent Current	$V_{IN} - V_O = 5\text{V}$		5	10	mA
I_O	Current Limit	$V_{IN} - V_O = 5\text{V}$	1000	1250	1600	mA
ϵ_N	Output Noise(% V_O)	$B = 10\text{Hz}$ to 10kHz , $T_J = 25^{\circ}\text{C}$		100		μV
SVR	Supply Voltage Rejection	$I_O = 300\text{mA}$, $f = 120\text{Hz}$, $V_{IN} - V_O = 3\text{V}$, $V_{RIPPLE} = 1\text{V}_{PP}$	60	75		dB

300mA L.D.O VOLTAGE REGULATOR

TJ1117GSF

For 2.5V Output Voltage

($T_A=25^{\circ}\text{C}$, $C_{IN} = C_O = 10\mu\text{F}$ unless otherwise specified)

Symbol	Parameters	Condition	Min.	Typ.	Max.	Unit
V_O	Output Voltage	$V_{IN} = 4.0\text{V}$, $I_O = 10\text{mA}$	2.475	2.5	2.525	V
V_O	Output Voltage	$V_{IN} = 4.0\text{V}$ to 12V , $I_O = 0\text{mA}$ to 300mA ($T_J = 0 \sim 125^{\circ}\text{C}$)	2.450		2.550	V
ΔV_{LINE}	Line Regulation	$I_O = 0\text{mA}$, $V_{IN} = 4.0\text{V}$ to 12V		0.1	0.2	%
ΔV_{LOAD}	Load Regulation	$I_O = 0\text{mA}$ to 300mA , $V_{IN} = 4.5\text{V}$		0.2	0.4	%
V_{IN}	Operating Input Voltage				12	V
I_D	Quiescent Current	$V_{IN} - V_O = 5\text{V}$		5	10	mA
I_O	Current Limit	$V_{IN} - V_O = 5\text{V}$	1000	1250	1600	mA
ϵ_N	Output Noise(% V_O)	$B = 10\text{Hz}$ to 10kHz , $T_J = 25^{\circ}\text{C}$		100		μV
SVR	Supply Voltage Rejection	$I_O = 300\text{mA}$, $f = 120\text{Hz}$, $V_{IN} - V_O = 3\text{V}$, $V_{RIPPLE} = 1V_{PP}$	60	75		dB

For 3.3V Output Voltage

($T_A=25^{\circ}\text{C}$, $C_{IN} = C_O = 10\mu\text{F}$ unless otherwise specified)

Symbol	Parameters	Condition	Min.	Typ.	Max.	Unit
V_O	Output Voltage	$V_{IN} = 4.8\text{V}$, $I_O = 10\text{mA}$	3.267	3.3	3.333	V
V_O	Output Voltage	$V_{IN} = 4.8\text{V}$ to 12V , $I_O = 0\text{mA}$ to 300mA ($T_J = 0 \sim 125^{\circ}\text{C}$)	3.234		3.366	V
ΔV_{LINE}	Line Regulation	$I_O = 0\text{mA}$, $V_{IN} = 4.8\text{V}$ to 12V		0.1	0.2	%
ΔV_{LOAD}	Load Regulation	$I_O = 0\text{mA}$ to 300mA , $V_{IN} = 5.3\text{V}$		0.2	0.4	%
V_{IN}	Operating Input Voltage				12	V
I_D	Quiescent Current	$V_{IN} - V_O = 5\text{V}$		5	10	mA
I_O	Current Limit	$V_{IN} - V_O = 5\text{V}$	1000	1250	1600	mA
ϵ_N	Output Noise(% V_O)	$B = 10\text{Hz}$ to 10kHz , $T_J = 25^{\circ}\text{C}$		100		μV
SVR	Supply Voltage Rejection	$I_O = 300\text{mA}$, $f = 120\text{Hz}$, $V_{IN} - V_O = 3\text{V}$, $V_{RIPPLE} = 1V_{PP}$	60	75		dB

300mA L.D.O VOLTAGE REGULATOR

TJ1117GSF

For 5.0V Output Voltage

($T_A=25^\circ\text{C}$, $C_{IN} = C_O = 10\mu\text{F}$ unless otherwise specified)

Symbol	Parameters	Condition	Min.	Typ.	Max.	Unit
V_O	Output Voltage	$V_{IN} = 6.5\text{V}$, $I_O = 10\text{mA}$	4.950	5.0	5.050	V
V_O	Output Voltage	$V_{IN} = 6.5\text{V}$ to 15V , $I_O = 0\text{mA}$ to 300mA ($T_J = 0 \sim 125^\circ\text{C}$)	4.900		5.100	V
ΔV_{LINE}	Line Regulation	$I_O = 0\text{mA}$, $V_{IN} = 6.5\text{V}$ to 15V		0.1	0.2	%
ΔV_{LOAD}	Load Regulation	$I_O = 0\text{mA}$ to 300mA , $V_{IN} = 7.0\text{V}$		0.2	0.4	%
V_{IN}	Operating Input Voltage				12	V
I_D	Quiescent Current	$V_{IN} - V_O = 5\text{V}$		5	10	mA
I_O	Current Limit	$V_{IN} - V_O = 5\text{V}$	1000	1250	1600	mA
ϵ_N	Output Noise(% V_O)	$B = 10\text{Hz}$ to 10kHz , $T_J = 25^\circ\text{C}$		100		μV
SVR	Supply Voltage Rejection	$I_O = 300\text{mA}$, $f = 120\text{Hz}$, $V_{IN} - V_O = 3\text{V}$, $V_{RIPPLE} = 1\text{V}_{PP}$	60	75		dB

For All Output Voltage

($T_A=25^\circ\text{C}$, $C_{IN} = C_O = 10\mu\text{F}$ unless otherwise specified)

Symbol	Parameters	Condition	Min.	Typ.	Max.	Unit
V_D	Dropout Voltage	$I_O = 300\text{mA}$		1.3		V
	Temperature Stability			0.5		%
	Long Term Stability	1000 hrs, $T_J = 125^\circ\text{C}$		0.3		%
	Thermal Regulation	$T_A = 25^\circ\text{C}$ 30ms Pulse		0.003		%/W

APPLICATION CIRCUIT

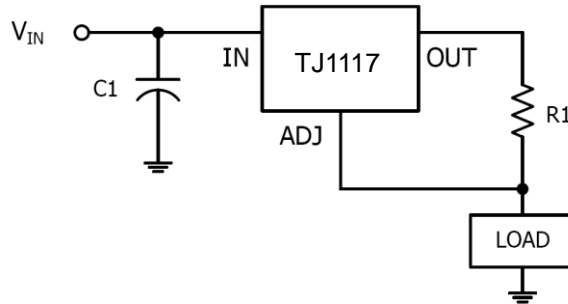

Fig.1 300mA Current Output

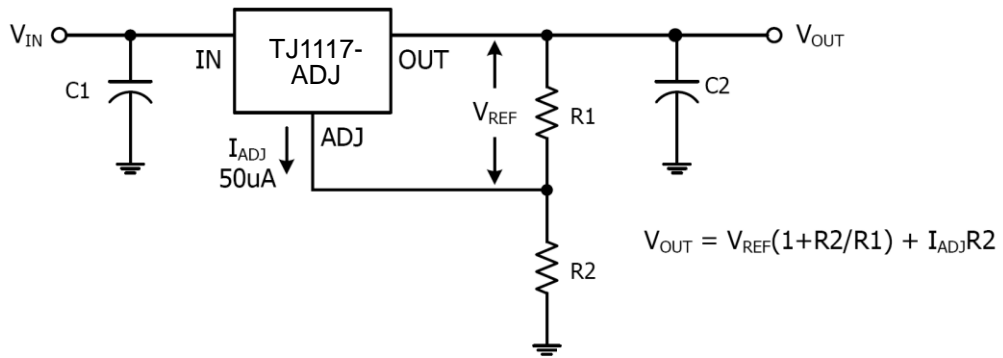

Fig.2 Typical Adjustable Regulator

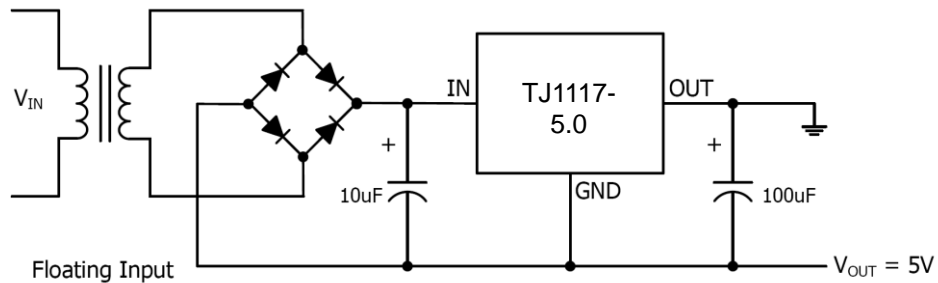

Fig.3 Negative Supply

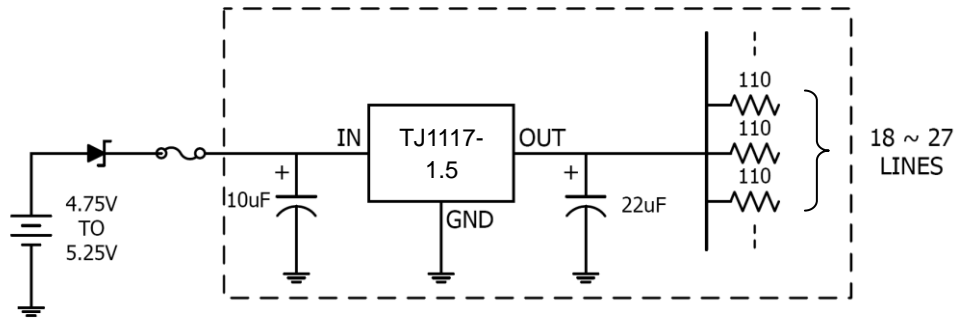

Fig.4 Active Terminator for SCSI-2BUS

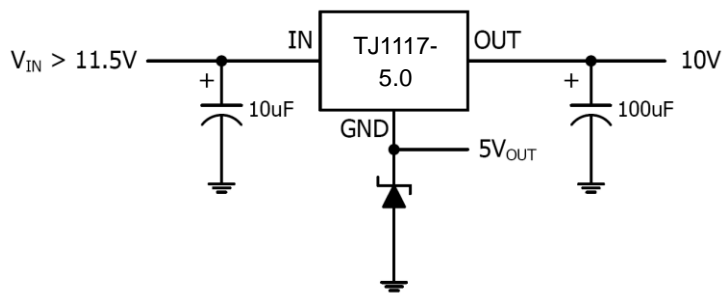

Fig.5 Voltage Regulator with Reference

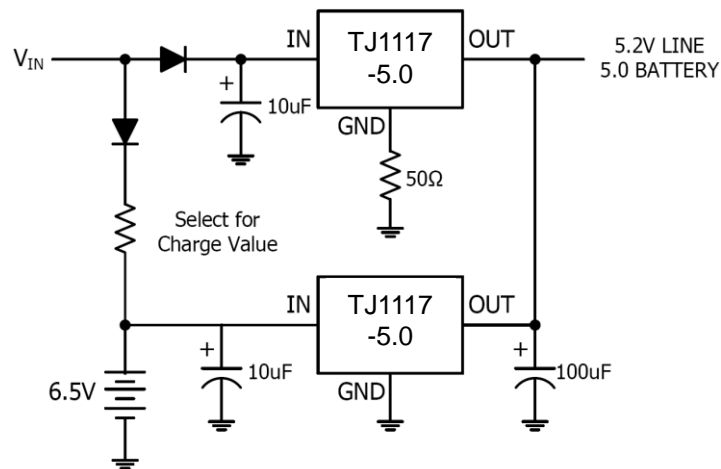
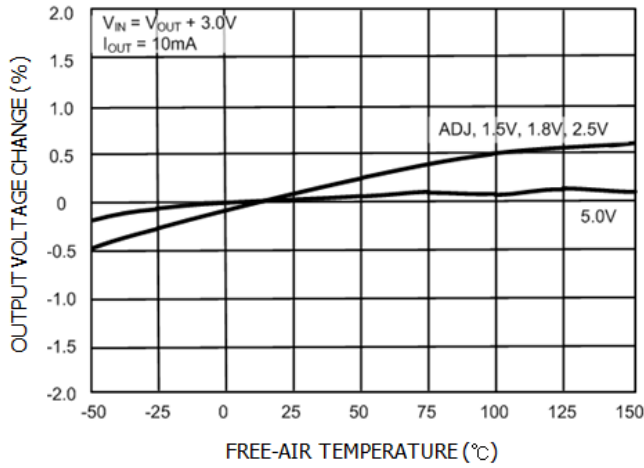
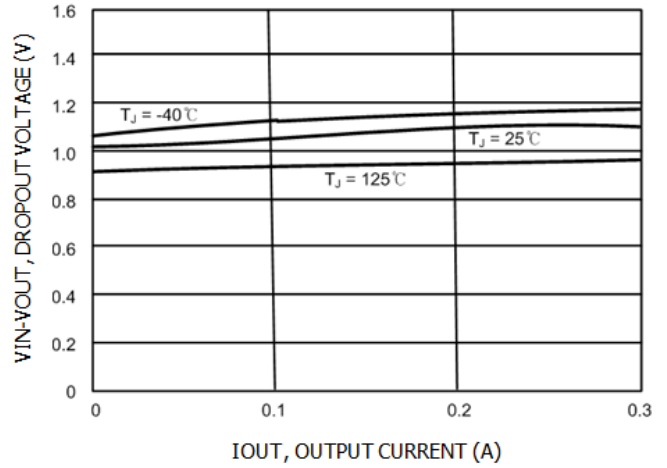

Fig.6 Battery Backed-up Regulated Supply

TYPICAL OPERATING CHARACTERISTICS



OUTPUT VOLTAGE CHANGE vs. TEMPERATURE



DROPOUT VOLTAGE vs. OUTPUT CURRENT

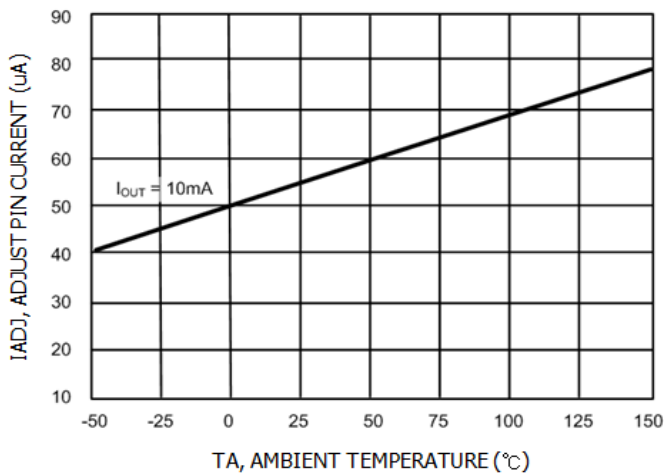

ADJ PIN CURRENT vs. AMBIENT TEMPERATURE

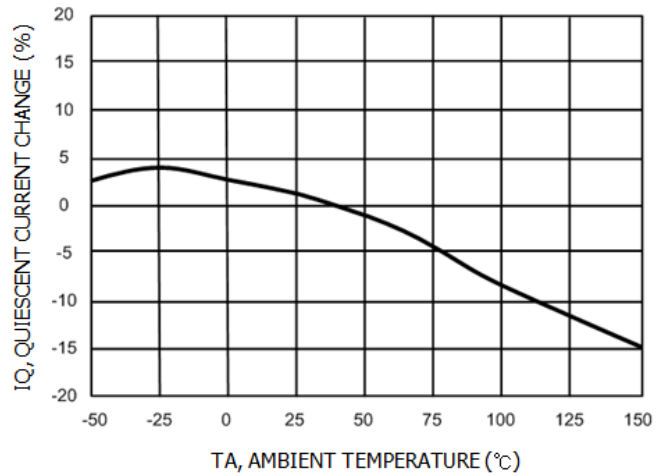

QUIESCENT CURRENT CHANGE vs. AMBIENT TEMPERATURE

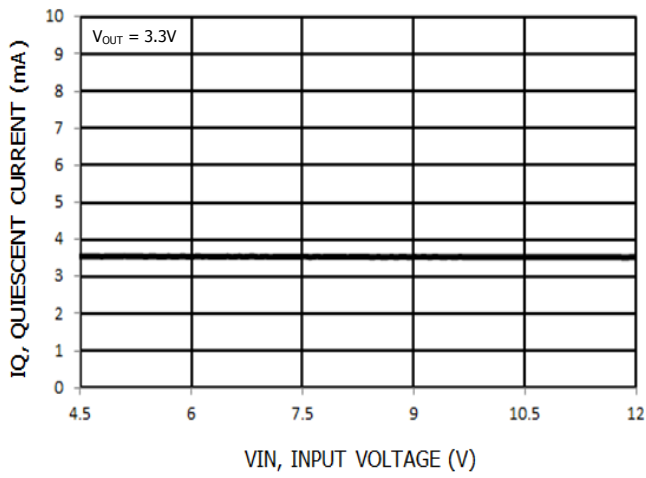

QUIESCENT CURRENT vs. INPUT VOLTAGE

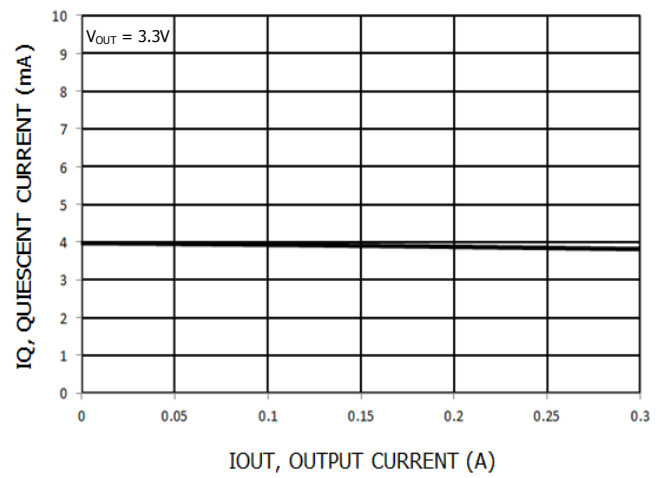

QUIESCENT CURRENT vs. OUTPUT CURRENT

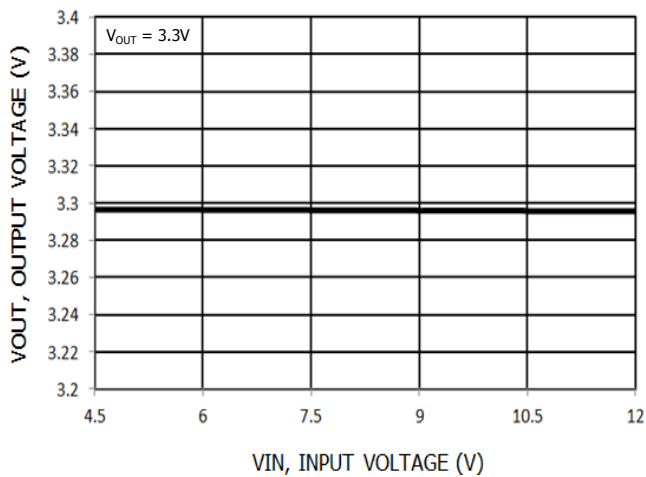

OUTPUT VOLTAGE vs. INPUT VOLTAGE

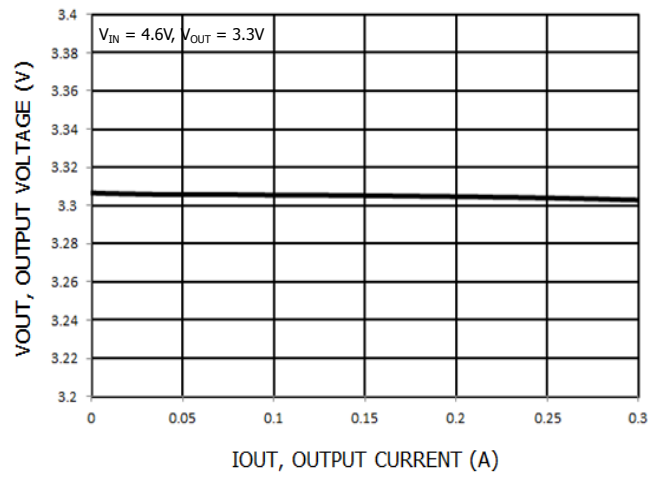

OUTPUT VOLTAGE vs. OUTPUT CURRENT

APPLICATION INFORMATION

Maximum Output Current Capability

The TJ1117 can deliver a continuous current of 300mA over the full operating junction temperature range. However, the output current is limited by the restriction of power dissipation which differs from packages. A heat sink may be required depending on the maximum power dissipation and maximum ambient temperature of application. With respect to the applied package, the maximum output current of 300mA may be still undeliverable due to the restriction of the power dissipation of TJ1117. Under all possible conditions, the junction temperature must be within the range specified under operating conditions. The temperatures over the device are given by:

$$T_C = T_A + P_D \times \theta_{CA} / \quad T_J = T_C + P_D \times \theta_{JC} / \quad T_J = T_A + P_D \times \theta_{JA}$$

where T_J is the junction temperature, T_C is the case temperature, T_A is the ambient temperature, P_D is the total power dissipation of the device, θ_{CA} is the thermal resistance of case-to-ambient, θ_{JC} is the thermal resistance of junction-to-case, and θ_{JA} is the thermal resistance of junction to ambient. The total power dissipation of the device is given by:

$$\begin{aligned} P_D &= P_{IN} - P_{OUT} = (V_{IN} \times I_{IN}) - (V_{OUT} \times I_{OUT}) \\ &= (V_{IN} \times (I_{OUT} + I_{GND})) - (V_{OUT} \times I_{OUT}) = (V_{IN} - V_{OUT}) \times I_{OUT} + V_{IN} \times I_{GND} \end{aligned}$$

where I_{GND} is the operating ground current of the device which is specified at the Electrical Characteristics. The maximum allowable temperature rise (TR_{max}) depends on the maximum ambient temperature (T_{Amax}) of the application, and the maximum allowable junction temperature (T_{Jmax}):

$$TR_{max} = T_{Jmax} - T_{Amax}$$

The maximum allowable value for junction-to-ambient thermal resistance, θ_{JA} , can be calculated using the formula:

$$\theta_{JA} = TR_{max} / P_D = (T_{Jmax} - T_{Amax}) / P_D$$

TJ1117 is available in SOT23 package. The thermal resistance depends on amount of copper area or heat sink, and on air flow. If the maximum allowable value of θ_{JA} calculated above is over 300°C/W for SOT-23 package, no heat sink is needed since the package can dissipate enough heat to satisfy these requirements. If the value for allowable θ_{JA} falls near or below these limits, a heat sink or proper area of copper plane is required. In summary, the absolute maximum ratings of thermal resistances are as follow:

Absolute Maximum Ratings of Thermal Resistance

Characteristic	Symbol	Rating	Unit
Thermal Resistance Junction-To-Ambient / SOT-23	$\theta_{JA-SOT-23}$	300	°C/W

No heat sink / No air flow / No adjacent heat source / 0.066 inch² copper area. ($T_A=25^\circ\text{C}$)

In case that there is no cooling solution and no heat sink / minimum copper plane area for heat sink, the maximum allowable power dissipation of each package is as follow;

Characteristic	Symbol	Rating	Unit
Maximum Allowable Power Dissipation at $T_A=25^{\circ}\text{C}$ / SOT-23	$P_{DMax-SOT-23}$	0.333	W

- Please note that above maximum allowable power dissipation is based on the minimum copper plane area which does not exceed the proper footprint of the package. And the ambient temperature is 25°C .

If proper cooling solution such as heat sink, copper plane area, air flow is applied, the maximum allowable power dissipation could be increased. However, if the ambient temperature is increased, the allowable power dissipation would be decreased.

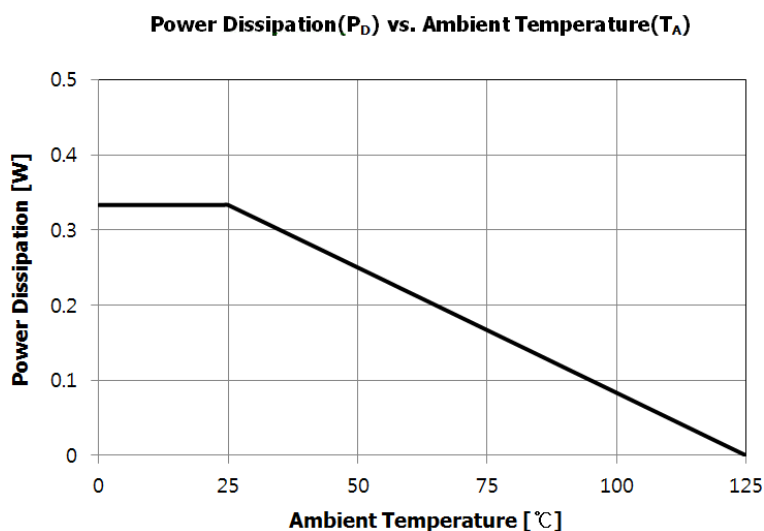

REVISION NOTICE

The description in this datasheet can be revised without any notice to describe its electrical characteristics properly.