

FEATURES

- 3A Output Current
- Programmable Soft-Start
- 100mΩ Internal Power MOSFET Switch
- Stable with Low ESR Output Ceramic Capacitors
- 20μA Shutdown Mode
- Fixed Operating Frequency 385KHz
- Thermal Shutdown
- Cycle-by-Cycle Over Current Protection
- Wide 4.75 to 20V Operating Input Range
- Output Adjustable From 1.22 to 18V
- Under Voltage Lockout

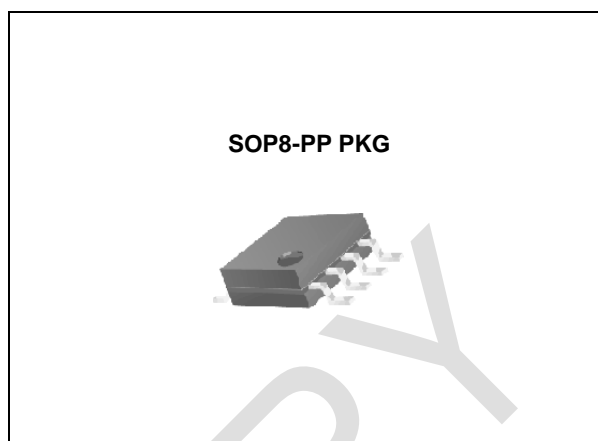

ORDERING INFORMATION

Device (Marking)	Package
TJ1583GDP	SOP8-PP

DESCRIPTION

The TJ1583 is a step-down regulator with a built in internal Power MOSFET. It achieves 3A continuous output current over a wide input supply range with excellent load and line regulation. Current mode operation provides fast transient response and eases loop stabilization. Fault condition protection includes cycle-by-cycle current limiting and thermal shutdown. In shutdown mode the regulator draws 20μA of supply current. The TJ1583 requires a minimum number of readily available external components to complete a 3A step down DC to DC converter solution.

Absolute Maximum Ratings

CHARACTERISTIC	SYMBOL	MIN.	MAX.	UNIT
Supply Voltage	V_{IN}	-0.3	24	V
Switch Voltage	V_{SW}	-1.0	$V_{IN}+0.3$	V
Boost Pin Voltage	V_{BST}	$V_{SW} - 0.3$	$V_{SW} + 6$	V
EN / SS / COMP Pins Voltage	$V_{EN} / V_{SS} / V_{COMP}$	-0.3	6	V
FB Pin Voltage	V_{FB}	-0.3	6	V
Junction Temperature	T_J	-40	150	°C
Storage Temperature Range	T_{STG}	-65	150	°C

Recommended Operating Conditions

CHARACTERISTIC	SYMBOL	MIN.	MAX.	UNIT
Supply Voltage	V_{IN}	4.75	20	V
Output Voltage	V_{OUT}	1.22	18	V
Junction Temperature	T_J	-40	125	°C
Ambient Operating Temperature	T_A	-40	85	°C

(1) For proper operation of device, V_{IN} should be within Max. Operating Input Voltage as defined in Electrical Characteristics.

Ordering Information

Order No.	Package	Description	Package Marking	Supplied As
TJ1583GDP	SOP8-PP (Halogen Free)	3A Step-Down Switching Regulator	TJ1583	Reel

PIN CONFIGURATION

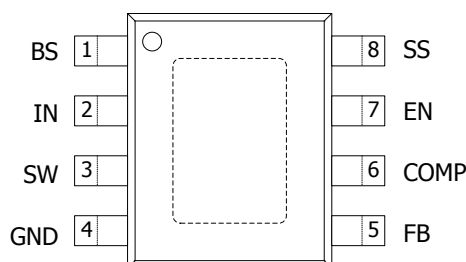

SOP8-PP (With Exposed PAD)

PIN DESCRIPTION

Pin No.	Pin Name	Pin Description
1	BS	High-Side Gate Drive Boost Input. BS supplies the drive for the high-side n-channel MOSFET switch. Connect a capacitor from SW to BS to power the high side switch.
2	IN	Power Input. IN supplies the power to the IC, as well as the step-down converter switches. Drive IN with a 4.75V to 20V power source. Bypass IN to GND with a suitably large capacitor to eliminate noise on the input to the IC.
3	SW	Power Switching Output. SW is the switching node that supplies power to the output. Connect the output LC filter from SW to the output load.
4	GND	Ground.
5	FB	Feedback Input. FB senses the output voltage to regulate that voltage.
6	COMP	Compensation Node. COMP is used to compensate the regulation control loop. Connect a series RC network from COMP to GND to compensate the regulation control loop. In some cases, an additional capacitor from COMP to GND is required.
7	EN	Enable Input. EN is a digital input that turns the regulator on or off. Insert 10kΩ at enable pin. (Refer to typical application circuit)
8	SS	Soft Start Control Input. SS controls the soft start period. Connect a capacitor from SS to GND to set the soft-start period.
-	Exposed Thermal PAD	Pad for heat sinking purposes. Connect to ground plane using multiple vias.

TYPICAL APPLICATION CIRCUIT

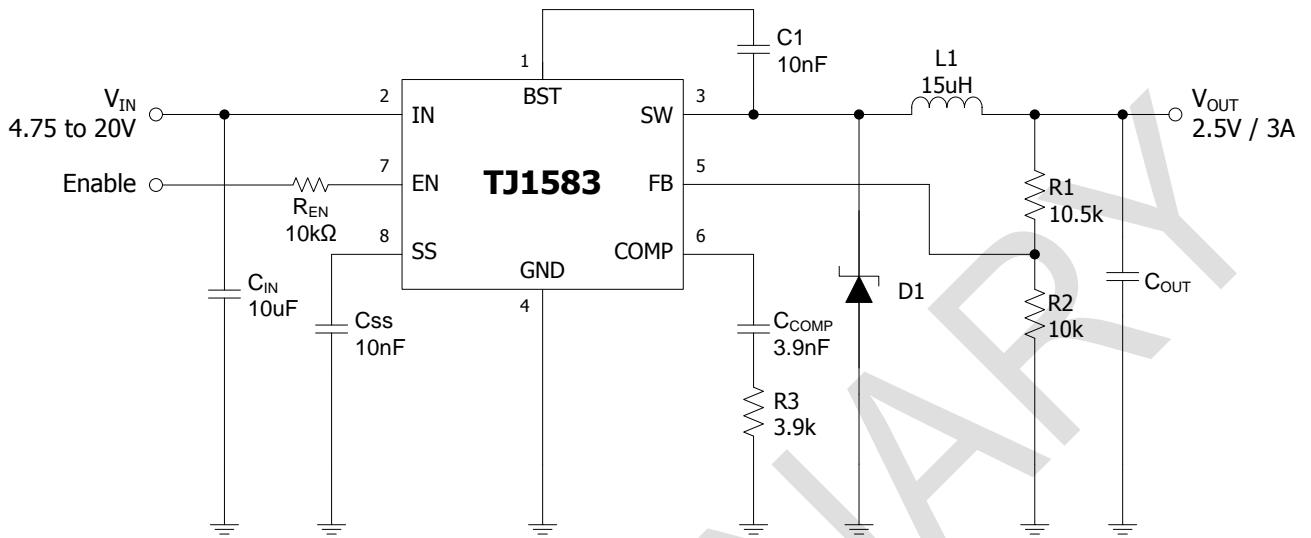

ELECTRICAL CHARACTERISTICS ($V_{IN} = 12V$, $T_A = 25^\circ C$, Unless otherwise noted)

PARAMETER	SYMBOL	TEST CONDITION	MIN.	TYP.	MAX.	UNIT
Shutdown Supply Current	I_{SD}	$V_{EN}=0V$	-	20	30	μA
Supply Current	I_Q	$V_{EN} = 2.6V, V_{FB} = 1.4V$	-	1.1	1.4	mA
Feedback Voltage	V_{FB}	$4.75V \leq V_{IN} \leq 20V$	1.194	1.222	1.250	V
High-Side Switch Leakage Current	I_{LEAK}	$V_{EN} = 0V, V_{SW} = 0V$	-	-	10	μA
EN Threshold Voltage	V_{EN}	$I_Q > 500\mu A$	0.9	1.2	1.5	V
Enable Pull Up Current	I_{EN}	$V_{EN} = 0V$	1.1	1.8	2.5	μA
Under Voltage Lockout Threshold	V_{UVLO}	V_{EN} Rising	2.37	2.54	2.71	V
Error Amplifier Voltage Gain	-	-	-	400	-	V/V
Error Amplifier Transconductance		$\Delta I_{COMP} = \pm 10\mu A$	-	1150	-	$\mu A/V$
High-Side Switch On Resistance	$R_{ON,HIGH}$	-	-	100	-	$m\Omega$
Low-Side Switch On Resistance	$R_{ON,LOW}$	-	-	10	-	Ω
Current Limit	I_{LIM}	-	-	5.5	-	A
COMP to Current Sense Transconductance	-	-	-	3.8	-	A/V
Oscillation Frequency	F_{OSC}	-	-	385	-	kHz
Minimum Duty Cycle	DC_{MIN}	$V_{FB} = 1.5V$	-	-	0	%
Maximum Duty Cycle	DC_{MAX}	$V_{FB} = 1.0V$	-	90	-	%
Under Voltage Lockout Threshold Hysteresis	-	-	-	210	-	mV
Soft-Start Period	-	$C_{SS} = 0.1\mu F$	-	10	-	ms

Notes:

- (1) The device may not function properly outside its operating input voltage range.
- (2) The required minimum input voltage for a regulated output depends on the output voltage and load condition.
- (3) Exceeding these ratings may damage the device.
- (4) Guaranteed by design.

TYPICAL OPERATING CHARACTERISTICS

VIN Turn-on, EN Pin Floating
VIN=12V, VOUT=3.3V, IOUT=0A

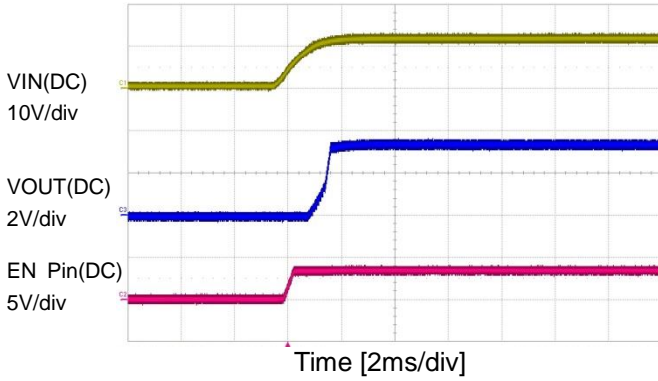

VIN Turn-on, EN Pin Floating
VIN=12V, VOUT=3.3V, IOUT=3A

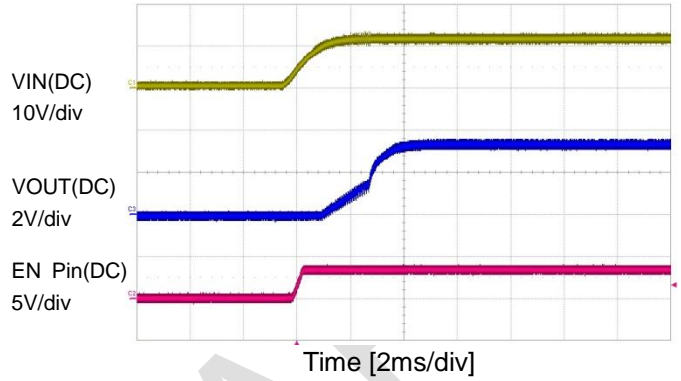

EN Turn-on
VIN=12V, VOUT=3.3V, IOUT=0A

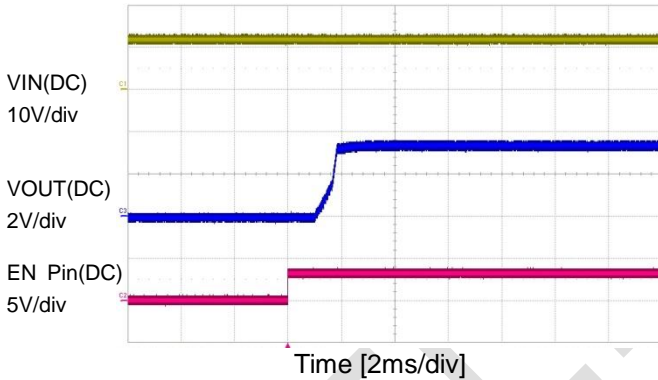

EN Turn-on
VIN=12V, VOUT=3.3V, IOUT=3A

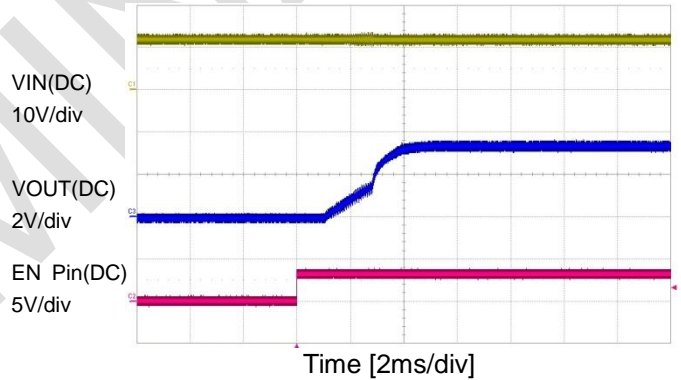

Operation
VIN=12V, VOUT=3.3V, IOUT=0A

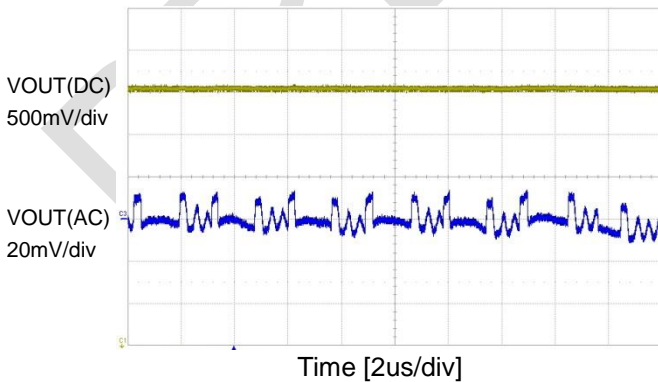

Operation
VIN=12V, VOUT=3.3V, IOUT=3A

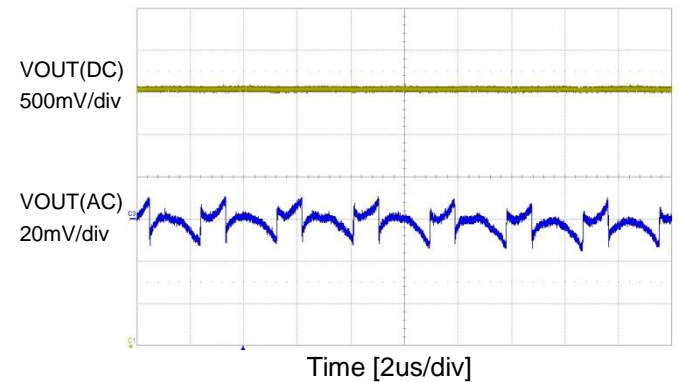

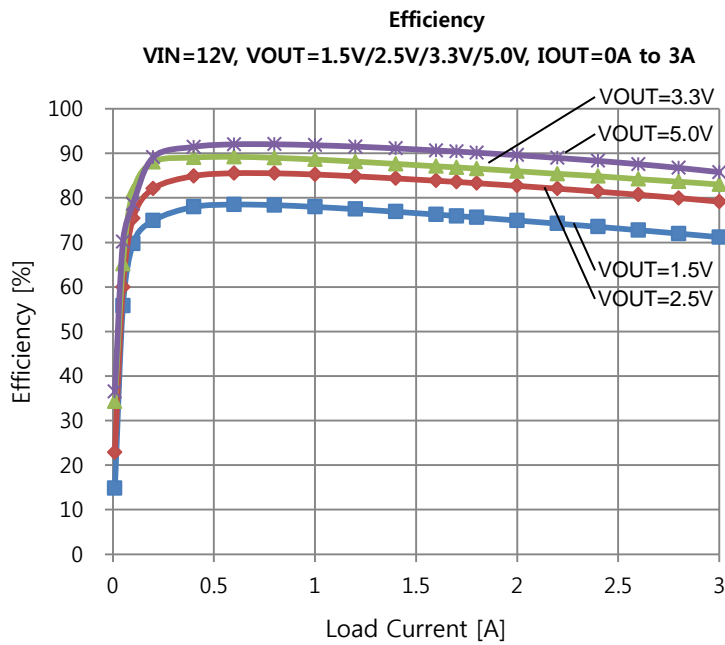
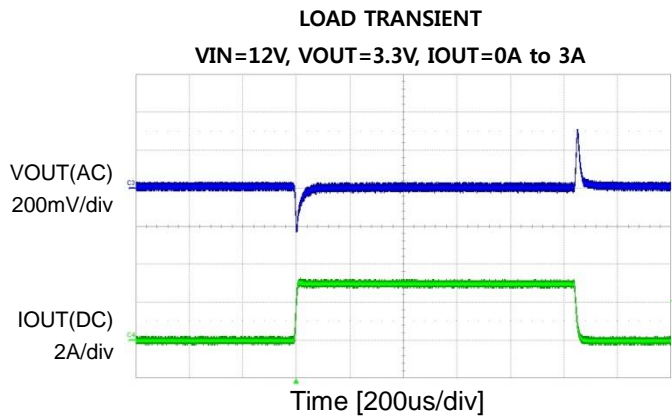

APPLICATION INFORMATION

The TJ1583 regulates input voltages from 4.75 to 20V down to an output voltage as low as 1.22V, and is able to supply up to 3A of load current. The TJ1583 uses current-mode control to regulate the output voltage. The output voltage is measured at FB through a resistive voltage divider and amplified through the internal error amplifier. The output current of the transconductance error amplifier is presented at COMP where a network compensates the regulation control system. The voltage at COMP is compared to the switch current measured internally to control the output voltage. The converter uses internal N-Channel MOSFET switch to step-down the input voltage to the regulated output voltage. Since the MOSFET requires a gate voltage greater than the input voltage, a boost capacitor connected between SW and BS drives the gate. The capacitor is internally charged while SW is low. An internal 10Ω switch from SW to GND is used to insure that SW is pulled to GND when SW is low to fully charge the BS capacitor.

Inductor Selection Guide

The inductor is required to supply constant current to the output load while being driven by the switched input voltage. A larger value inductor will result in less ripple current and lower output ripple voltage. However, larger value inductors have a larger physical size, higher series resistance, and/or lower saturation current. A good rule for determining the inductance to use is to allow the inductor peak-to-peak ripple current to be approximately 30% of the maximum switch current limit. Also, make sure that the peak inductor current is below the maximum switch current limit. The inductance value can be calculated by:

$$L = \frac{V_{OUT}}{F_{SW} \times \Delta I_L} \times \left(1 - \frac{V_{OUT}}{V_{IN}}\right)$$

Where V_{IN} is the input voltage, F_{sw} is the 385KHz switching frequency and ΔI_L is the peak-to-peak inductor ripple current. Choose an inductor that will not saturate under the maximum inductor peak current.

Table 1 - Recommended minimum inductance ratings

VOUT [V]	L1 [uH]
1.5	6.8
1.8	10
2.5	10
3.3	15
5.0	22

Compensation Components

The system stability and transient response are controlled through the COMP pin. COMP is the output of the internal transconductance error amplifier. A series capacitor-resistor combination sets a pole-zero combination to control the characteristics of the control system.

Table 2 - Recommended compensation Values for Typical Output Voltage

V _{OUT} [V]	C _{OUT} [uF]	R3 [kΩ]	C _{COMP} [nF]
2.5	22	3.9	3.9
3.3	22	4.7	3.3
5	22	7.5	2.2
12	22	10	2.7

Layout Guidelines:

In order to achieve optimal electrical and thermal performance for high frequency converters, special attention must be paid to the PCB layouts. The goal of layout optimization is to identify the high di/dt loops and minimize them. The following guidelines should be used to ensure proper operation of the converters.

1. A ground plane is suggested to minimize switching noises and trace losses and maximize heat transferring.
2. Start the PCB layout by placing the power components first. Arrange the power circuit to achieve a clean power flow route. Put all power connections on one side of the PCB with wide copper filled areas if possible.
3. The VIN bypass capacitor should be placed next to the VIN and GND pins.
4. The trace connecting the feedback resistors to the output should be short, direct and far away from any noise sources such as switching node and switching components.
5. Minimize the loop including input capacitor, the TJ1583 and freewheeling diode. This loop passes high di/dt current. Make sure the trace width is wide enough to reduce copper losses in this loop. Maximize the trace width of the loop connecting the inductor, freewheeling diode D2 and the output capacitor.
7. Connect the ground of the feedback divider and the compensation components directly to the GND pin of the TJ1583 by using a separate ground trace.
8. Connect Pin 4 to a large copper area to remove the IC heat and increase the power capability of the TJ1583. A few feed through holes are required to connect this large copper area to a ground plane to further improve the thermal environment of the TJ1583. The traces attached to other pins should be as wide as possible for the same purpose.

REVISION NOTICE

The description in this datasheet can be revised without any notice to describe its electrical characteristics properly.

PRELIMINARY