

Features

- 65 ms Cycle Time for Crypto Algorithm Programming
- Encryption Time < 10 ms, < 30 ms Optional
- Identification Transponder in Plastic Cube
- Contactless Read/Write Data Transmission
- High-security Crypto Algorithm Optional
- Inductive Coupled Power Supply at 125 kHz
- Basic Component R/W e5561 IDIC®
- Built-in Coil and Capacitor for Circuit Antenna
- Starts with Cyclical Data Read Out
- Programmable Adaption of Resonance Frequency
- 128-bit User-programmable EEPROM
- Typical < 50 ms to Write and Verify a Block
- Read/Write Protection by Lock Bits
- Options Set by EEPROM:
 - Bit Rate (Bit/s): Rf/32, Rf/64
 - Modulation: Manchester, Bi-phase

Application

- Car Immobilizers with Higher Security Level
- High-security Identification Systems

1. Description

The TK5561A-PP is a complete transponder integrating all important functions for immobilizer and identification systems. It consists of a plastic cube which accommodates the crypto IDIC e5561A and the antenna realized as tuned LC-circuit. The TK5561A-PP is a R/W crypto transponder for applications which demand higher security levels than those which standard R/W transponders can fulfil. For this reason, the TK5561A-PP has an additional encryption algorithm block which enables a base station to authenticate the transponder. Any attempt to fake the base station with a wrong transponder will be recognized immediately. For authentication, the base station transmits a challenge to the TK5561A-PP. This challenge is encrypted by both the IC and the base station. Both should possess the same secret key. Only then can the results be expected to be equal.

For detailed technical information about functions, configurations etc., please refer to the e5561 data sheet.



Read/Write Crypto Transponder for Short Cycle Time

TK5561A-PP

Figure 1-1. Transponder and Base Station

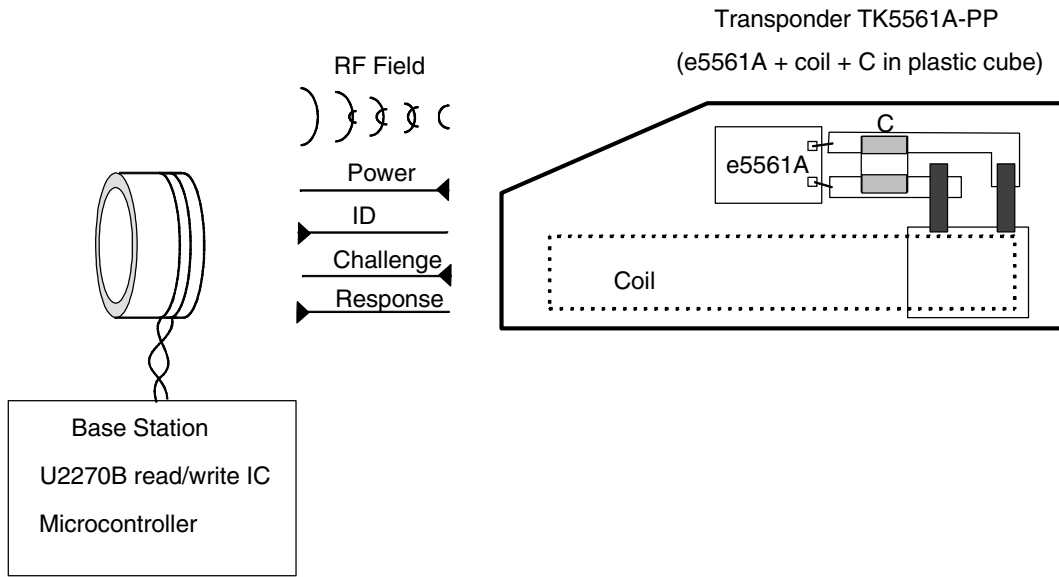
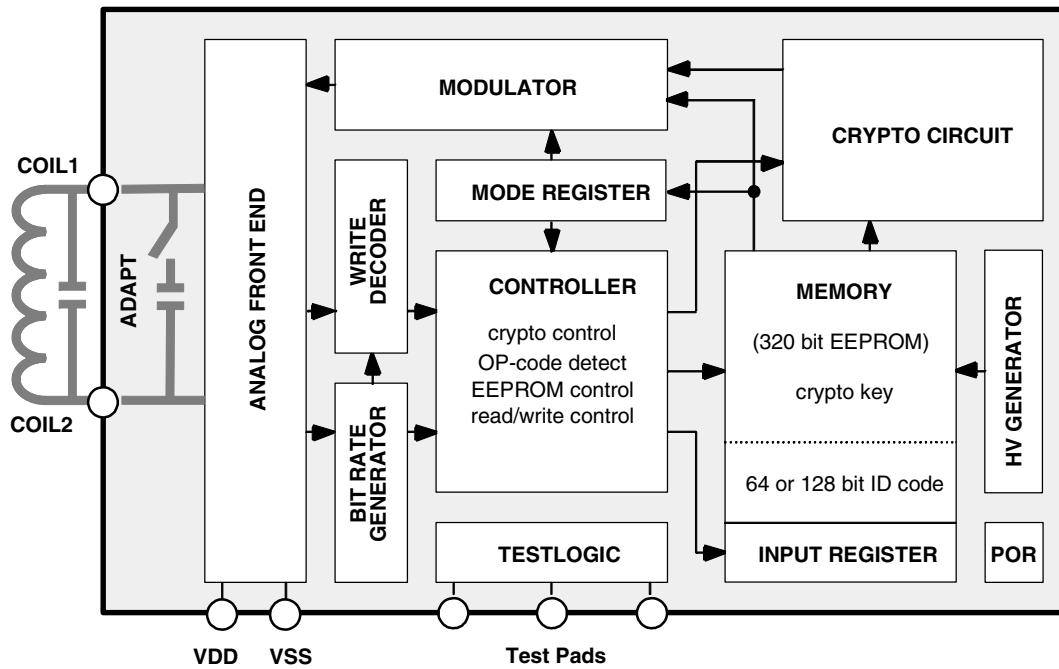

Figure 1-2. Block Diagram



Note: Please consider restriction in using the "Adapt"-feature described in the e5561 datasheet.

2. General

The transponder is the mobile part of the closed coupled identification system (see [Figure 1-1](#)), whereas the read/write base station is based on the U2270B or on discrete solutions, and the read/write transponder is based on the e5561A IDIC.

The transponder is a plastic-cube device consisting of the following parts:

- The transponder antenna, with a tuned LC-circuit
- Read/write IDIC (e5561A) with EEPROM

3. Transponder Antenna

The antenna consists of a coil and a capacitor for tuning the circuit to the nominal carrier frequency of 125 kHz. The coil has a ferrite core to improve the read, write and programming operation distances.

4. Read/Write Crypto Identification

The e5561A is a member of the Atmel®'s contactless **IDentification IC** (IDIC) family, which are used in applications where information has to be transmitted without contacts. The IDIC is connected to a tuned LC circuit for power supply and bidirectional data communication (**Read/Write**) to a base station.

The on-chip non-volatile memory of the 320-bit EEPROM (10 blocks, 32 bits each) can be read and written blockwise by a read/write base station, e.g. based on the U2270B. Up to four blocks consisting of the user programmable ID code, the crypto key and configurations are stored in six blocks. The crypto key and the ID code can be individually protected against overwriting.

The typical operational frequency of the TK5561A-PP is 125 kHz. Two data bit rates are programmable: $R_f/32$ and $R_f/64$. During the reading operation the incoming RF field is dampened bit-wise by an on-chip load. This AM-modulation is detected by the field generating base station unit. Data transmission starts after power-up with the transmission of the ID code and continues as long as the TK5561A-PP is powered.

Writing is carried out by means of Atmel's patented writing method. To transmit data to the TK5561A-PP the read/write base station has to interrupt the RF field for a short time to create a field gap. The information is encoded in the number of clock cycles between two subsequent gaps.

See the e5561A data sheet for detailed information of the IDIC.

5. Absolute Maximum Ratings

Stresses beyond those listed under “Absolute Maximum Ratings” may cause permanent damage to the device. This is a stress rating only and functional operation of the device at these or any other conditions beyond those indicated in the operational sections of this specification is not implied. Exposure to absolute maximum rating conditions for extended periods may affect device reliability.

Parameter	Symbol	Value	Unit
Operating temperature range	T_{amb}	-40 to +85	°C
Storage temperature range	T_{stg}	-40 to +125	°C
Maximum assembly temperature, $t < 5$ min	T_{ass}	170	°C
Magnetic field strength at 125 kHz	H_{pp}	1000	A/m

6. Operating Characteristics Transponder

$T_{amb} = 25^{\circ}\text{C}$, $f = 125$ kHz unless otherwise specified

Parameters	Test Conditions	Symbol	Min.	Typ.	Max.	Unit
Inductance		L		4.2		mH
LC Circuit, $H_{pp} = 20$ A/m						
Resonance frequency	$T_{amb} = -40$ to $+85^{\circ}\text{C}$	f_r	121	125	129	kHz
Quality factor		Q_{LC}	5	8	11	
Magnetic Field Strength (H)						
Maximum field strength where transponder does not modulate	No influence to other transponders in the field	$H_{pp\ not}$		5		A/m
Minimum Field Strength (H)						
Read mode	$T_{amb} = -40^{\circ}\text{C}$	$H_{pp\ -40}$			24	A/m
	$T_{amb} = 25^{\circ}\text{C}$	$H_{pp\ 25}$			18	A/m
	$T_{amb} = 85^{\circ}\text{C}$	$H_{pp\ 85}$			15	A/m
Programming mode	$T_{amb} = -40^{\circ}\text{C}$	$H_{pp\ -40}$			30	A/m
	$T_{amb} = 25^{\circ}\text{C}$	$H_{pp\ 25}$			35	A/m
	$T_{amb} = 85^{\circ}\text{C}$	$H_{pp\ 85}$			40	A/m
Lowest adapt frequency		f_{LA}	118	121	124.5	kHz
Highest adapt frequency		f_{HA}	125	128	131.5	kHz
Data retention EEPROM	$T = 25^{\circ}\text{C}$	$t_{retention}$	10			Years
Programming cycles EEPROM			100,000			
Programming time/block	RF = 125 kHz	t_p		16		ms
Maximum field strength		$H_{pp\ max}$			600	A/m

Figure 6-1. Typical Curve for Degree of Modulation

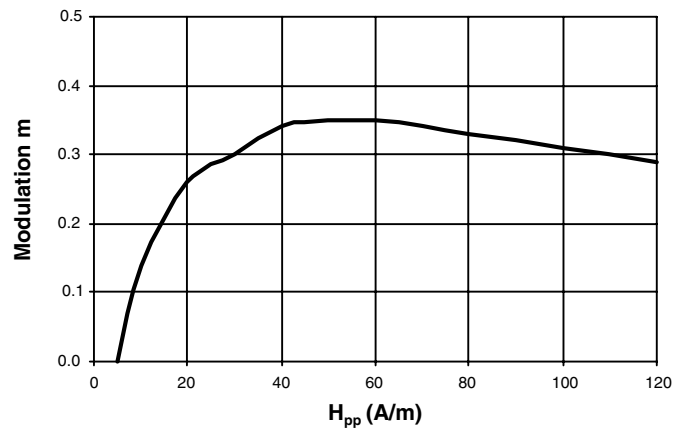
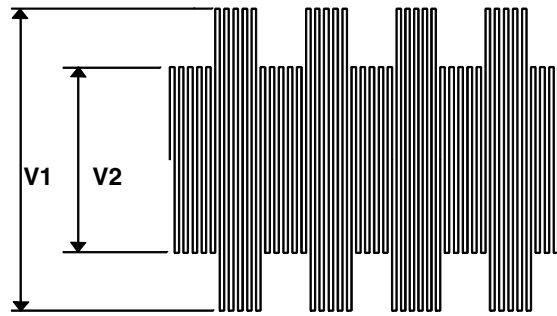

Figure 6-2. Measurement of the Degree of Modulation



$$m = \frac{V1 - V2}{V1 + V2}$$

7. Measurement Assembly

All parameters are measured in a Helmholtz-arrangement, which generates a homogenous magnetic field (see [Figure 7-1](#) and [Figure 7-2](#)). A function generator drives the field generating coils, so the magnetic field can be varied in frequency and field strength.

Figure 7-1. Testing Application

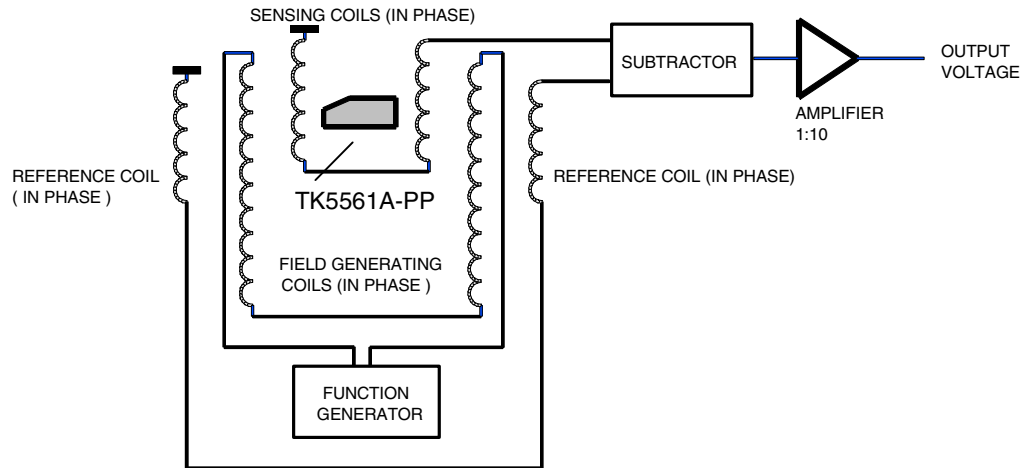
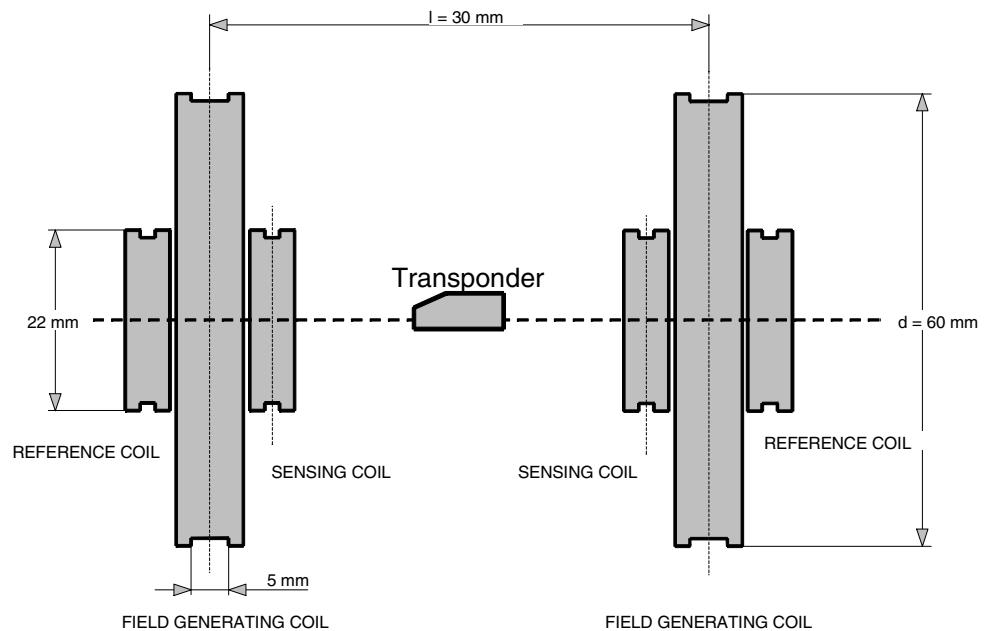

Figure 7-2. Testing Geometry



8. Writing Data into the TK5561A-PP

A write sequence of the TK5561A-PP is shown in [Figure 8-1](#). Writing data into the transponder occurs by interrupting the RF field with short gaps. After the start gap the write opcode (10) is transmitted. The next 32 bits contain the actual data. The last 4 bits denote the destination block address. If the correct number of bits have been received, the actual data is programmed into the specified memory block.

Figure 8-1. Write Protocol to Program the EEPROM

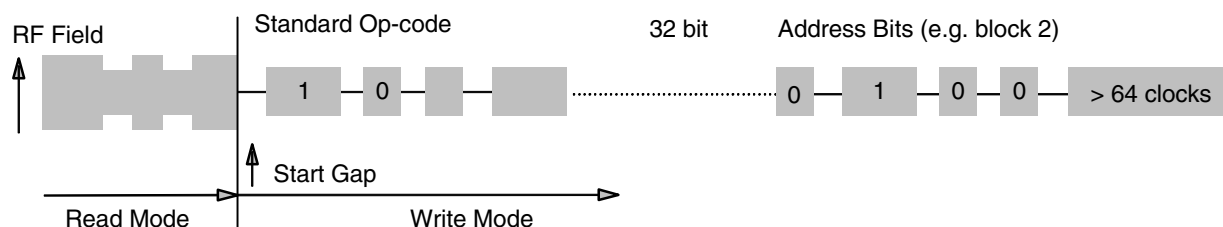

9. Writing Data Decoding

The time elapsing between two detected gaps is used to encode the information. As soon as a gap is detected, a counter starts counting the number of field clock cycles until the next gap is detected. Depending on how many field clocks elapse, the data is regarded as 0 or 1. The required number of field clocks is shown in [Figure 9-1](#). A valid 0 is assumed if the number of counted clock periods is between 16 and 31, for a valid 1 it is 48 or 63 respectively. Any other value being detected results in an error and the device exits write mode and returns to read mode.

Figure 9-1. Write Data Decoding Scheme

Field Clock Cycles	1	16	32	48	64
Write Data Decoder	fail	0	fail	1	writing done

EOT

10. Actual Device Behavior

The TK5561A-PP detects a gap if the voltage across the coils decreases below a peak-to-peak value of about 800 mV. Until then, the clock pulses are counted. The number given for a valid 0 or 1 (see [Figure 9-1 on page 7](#)) refers to the actual clock pulses counted by the device. However, there are always more clock pulses being counted than were applied by the base station. The reason for this is the fact that an RF field cannot be switched off immediately. The coil voltage decreases exponentially. So although the RF field coming from the base station is switched off, it takes some time until the voltage across the coils reaches the threshold peak-to-peak value of about 800 mV and the device detects the gap. Referring to the following diagram [Figure 10-1](#), this means that the device uses the times t_0 internal and t_1 internal. The exact times for t_0 and t_1 are dependent on the application (e.g., field strength, etc.)

Typical time frames are:

$$\begin{aligned}
 t_0 &= 60 \text{ to } 140 \mu\text{s} \\
 t_1 &= 300 \text{ to } 400 \mu\text{s} \\
 t_{\text{gap}} &= 150 \text{ to } 400 \mu\text{s}
 \end{aligned}$$

Antennas with a high Q-factor require longer times for t_{gap} and shorter time values for t_0 and t_1 .

Figure 10-1. Ideal and Actual Signal Behavior

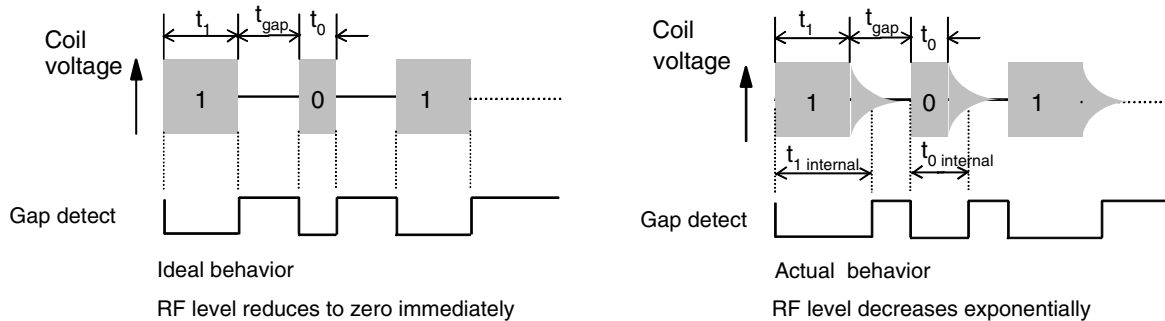

11. Operating Distance

The maximum distance between the base station and the TK5561A-PP depends mainly on the base station, the coil geometries and the chosen modulation options. Typical distances are 0 to 3 cm. A general maximum distance value cannot be given. A convenient way is to measure the TK5561A-PP within its environment. Rules for a correct base-station design can be provided upon request (see Antenna Design Guide).

12. Application

Figure 12-1. Complete Transponder System with the U2270B Read/Write IC

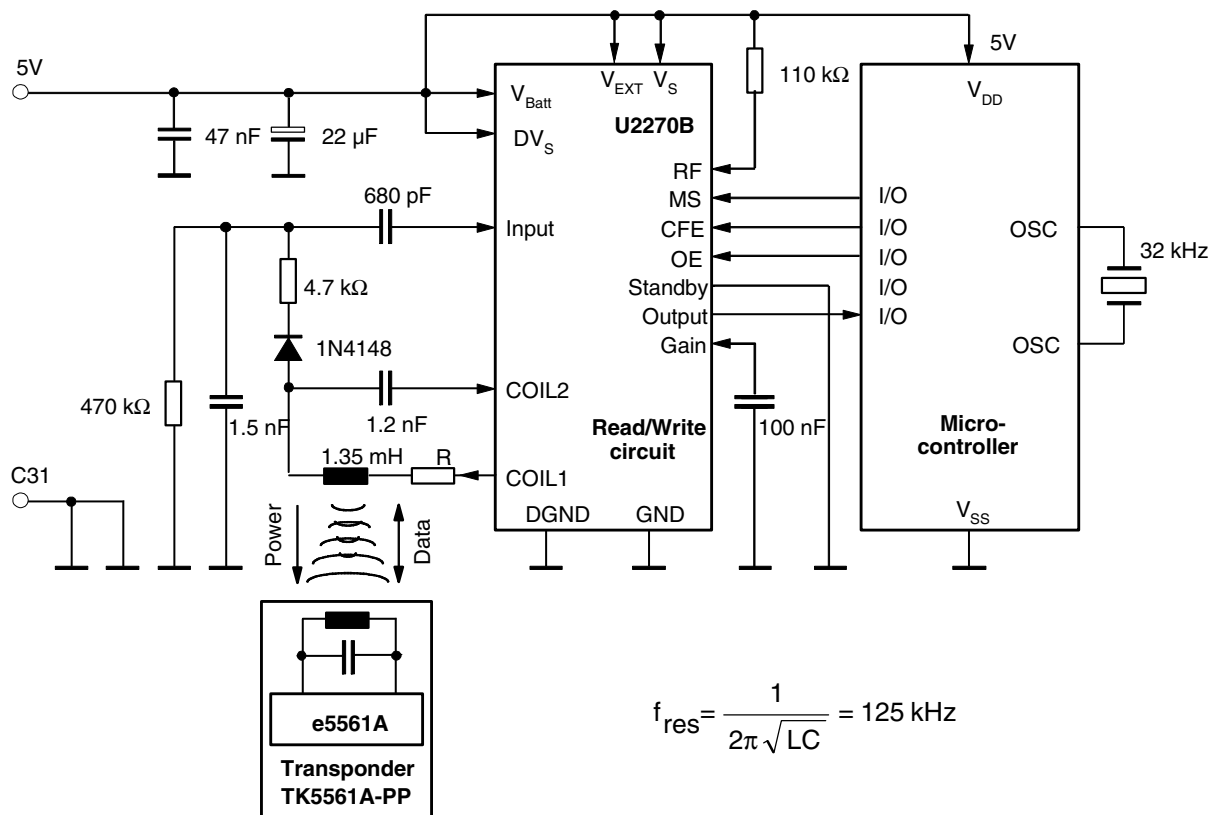

$$f_{res} = \frac{1}{2\pi\sqrt{LC}} = 125 \text{ kHz}$$

13. Mechanical Specification

Figure 13-1. Mechanical Drawing of Transponder

Dimensions in mm

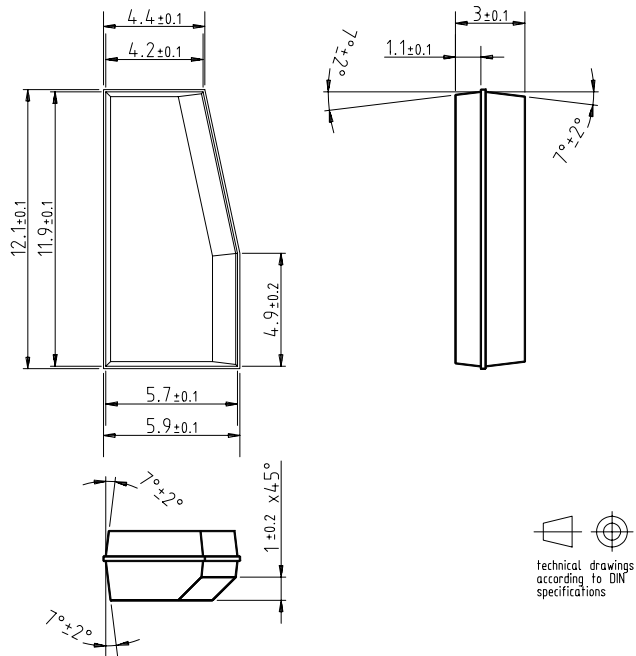

14. Ordering Information

Extended Type Number	Package	Remarks
TK5561A-PP	—	A = Version of e5561 IDIC

15. Revision History

Please note that the following page numbers referred to in this section refer to the specific revision mentioned, not to this document.

Revision No.	History
4682D-RFID-09/06	<ul style="list-style-type: none"> Put datasheet in a new template Pb-free logo on page 1 deleted Features on page 1 changed Note on page 2 added
4682C-RFID-06/05	<ul style="list-style-type: none"> Lead-free Logo on page 1 added
4682B-RFID-05/05	<ul style="list-style-type: none"> Put datasheet in a new template Figure 1.1 “Transponder and Base Station” on page 2 changed Figure 6.1 “Typical Curve for Degree of Modulation” on page 5 changed Figure 12.1 “Complete Transponder System with the U2270B Read/Write IC” on page 9 changed



Atmel Corporation

2325 Orchard Parkway
San Jose, CA 95131, USA
Tel: 1(408) 441-0311
Fax: 1(408) 487-2600

Regional Headquarters

Europe

Atmel Sarl
Route des Arsenaux 41
Case Postale 80
CH-1705 Fribourg
Switzerland
Tel: (41) 26-426-5555
Fax: (41) 26-426-5500

Asia

Room 1219
Chinachem Golden Plaza
77 Mody Road Tsimshatsui
East Kowloon
Hong Kong
Tel: (852) 2721-9778
Fax: (852) 2722-1369

Japan

9F, Tonetsu Shinkawa Bldg.
1-24-8 Shinkawa
Chuo-ku, Tokyo 104-0033
Japan
Tel: (81) 3-3523-3551
Fax: (81) 3-3523-7581

Atmel Operations

Memory

2325 Orchard Parkway
San Jose, CA 95131, USA
Tel: 1(408) 441-0311
Fax: 1(408) 436-4314

Microcontrollers

2325 Orchard Parkway
San Jose, CA 95131, USA
Tel: 1(408) 441-0311
Fax: 1(408) 436-4314

La Chantrerie
BP 70602
44306 Nantes Cedex 3, France
Tel: (33) 2-40-18-18-18
Fax: (33) 2-40-18-19-60

ASIC/ASSP/Smart Cards

Zone Industrielle
13106 Rousset Cedex, France
Tel: (33) 4-42-53-60-00
Fax: (33) 4-42-53-60-01

1150 East Cheyenne Mtn. Blvd.
Colorado Springs, CO 80906, USA
Tel: 1(719) 576-3300
Fax: 1(719) 540-1759

Scottish Enterprise Technology Park
Maxwell Building
East Kilbride G75 0QR, Scotland
Tel: (44) 1355-803-000
Fax: (44) 1355-242-743

RF/Automotive

Theresienstrasse 2
Postfach 3535
74025 Heilbronn, Germany
Tel: (49) 71-31-67-0
Fax: (49) 71-31-67-2340

1150 East Cheyenne Mtn. Blvd.
Colorado Springs, CO 80906, USA
Tel: 1(719) 576-3300
Fax: 1(719) 540-1759

Biometrics/Imaging/Hi-Rel MPU/ High-Speed Converters/RF Datacom

Avenue de Rochepleine
BP 123
38521 Saint-Egreve Cedex, France
Tel: (33) 4-76-58-30-00
Fax: (33) 4-76-58-34-80

Literature Requests

www.atmel.com/literature

Disclaimer: The information in this document is provided in connection with Atmel products. No license, express or implied, by estoppel or otherwise, to any intellectual property right is granted by this document or in connection with the sale of Atmel products. **EXCEPT AS SET FORTH IN ATMEL'S TERMS AND CONDITIONS OF SALE LOCATED ON ATMEL'S WEB SITE, ATMEL ASSUMES NO LIABILITY WHATSOEVER AND DISCLAIMS ANY EXPRESS, IMPLIED OR STATUTORY WARRANTY RELATING TO ITS PRODUCTS INCLUDING, BUT NOT LIMITED TO, THE IMPLIED WARRANTY OF MERCHANTABILITY, FITNESS FOR A PARTICULAR PURPOSE, OR NON-INFRINGEMENT. IN NO EVENT SHALL ATMEL BE LIABLE FOR ANY DIRECT, INDIRECT, CONSEQUENTIAL, PUNITIVE, SPECIAL OR INCIDENTAL DAMAGES (INCLUDING, WITHOUT LIMITATION, DAMAGES FOR LOSS OF PROFITS, BUSINESS INTERRUPTION, OR LOSS OF INFORMATION) ARISING OUT OF THE USE OR INABILITY TO USE THIS DOCUMENT, EVEN IF ATMEL HAS BEEN ADVISED OF THE POSSIBILITY OF SUCH DAMAGES.** Atmel makes no representations or warranties with respect to the accuracy or completeness of the contents of this document and reserves the right to make changes to specifications and product descriptions at any time without notice. Atmel does not make any commitment to update the information contained herein. Unless specifically provided otherwise, Atmel products are not suitable for, and shall not be used in, automotive applications. Atmel's products are not intended, authorized, or warranted for use as components in applications intended to support or sustain life.

© 2006 Atmel Corporation. All rights reserved. Atmel®, logo and combinations thereof, Everywhere You Are®, IDIC®, and others are registered trademarks or trademarks of Atmel Corporation or its subsidiaries. Other terms and product names may be trademarks of others.