

# TL2218-285, TL2218-285Y EXCALIBUR CURRENT-MODE SCSI TERMINATOR

SLVS072C – DECEMBER 1992 – REVISED OCTOBER 1995

## available features

- Fully Integrated 9-Channel SCSI Termination
- No External Components Required
- Maximum Allowed Current Applied at First High-Level Step
- 6-pF Typical Power-Down Output Capacitance
- Wide  $V_{\text{term}}^{\dagger}$  (Termination Voltage) Operating Range, 3.5 V to 5.5 V
- TTL-Compatible Disable Feature
- Compatible With Active Negation
- Thermal Regulation

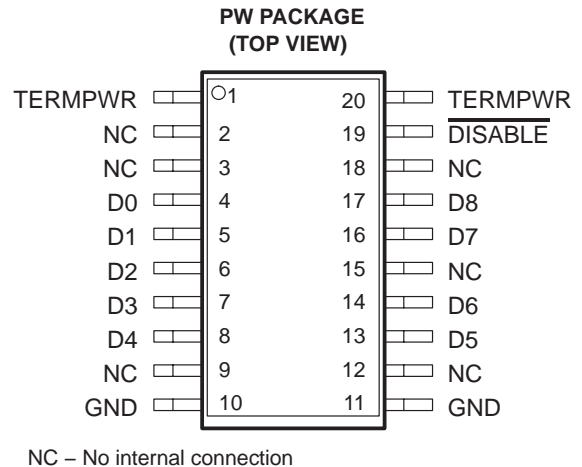

## description

The TL2218-285 is a current-mode 9-channel monolithic terminator specially designed for single-ended small-computer-systems-interface (SCSI) bus termination. A user-controlled disable function is provided to reduce standby power. No impedance-matching resistors or other external components are required for its operation as a complete terminator.

The device operates over a wide termination-voltage ( $V_{\text{term}}^{\dagger}$ ) range of 3.5 V to 5.5 V, offering an extra 0.5 V of operating range when compared to the minimum termination voltage of 4 V required by other integrated active terminators. The TL2218-285 functions as a current-sourcing terminator and supplies a constant output current of 23 mA into each asserted line. When a line is deasserted, the device senses the rising voltage level and begins to function as a voltage source, supplying a fixed output voltage of 2.85 V. The TL2218-285 features compatibility with active negation drivers and has a typical sink current capability of 20 mA.

The TL2218-285 is able to ensure that maximum current is applied at the first high-level step. This performance means that the device should provide a first high-level step exceeding 2 V even at a 10-MHz rate. Therefore, noise margins are improved considerably above those provided by resistive terminators.

A key difference between the TL2218-285 current-mode terminator and a Boulay terminator is that the TL2218-285 does not incorporate a low dropout regulator to set the output voltage to 2.85 V. In contrast with the Boulay termination concept, the accuracy of the 2.85 V is not critical with the current-mode method used in the TL2218-285 because this voltage does not determine the driver current. Therefore, the primary device specifications are not the same as with a voltage regulator but are more concerned with output current.

The  $\overline{\text{DISABLE}}$  terminal is TTL compatible and must be taken low to shut down the outputs. The device is normally active, even when  $\overline{\text{DISABLE}}$  is left floating. In the disable mode, only the device startup circuits remain active, thereby reducing the supply current to just 500  $\mu\text{A}$ . Output capacitance in the shutdown mode is typically 6 pF.

The TL2218-285 has on-board thermal regulation and current limiting, thus eliminating the need for external protection circuitry. A thermal regulation circuit that is designed to provide current limiting, rather than an actual thermal shutdown, is included in the individual channels of the TL2218-285. When a system fault occurs that leads to excessive power dissipation by the terminator, the thermal regulation circuit causes a reduction in the asserted-line output current sufficient to maintain operation. This feature allows the bus to remain active during a fault condition, which permits data transfer immediately upon removal of the fault. A terminator with thermal shutdown does not allow for data transfer until sufficient cooling has occurred. Another advantage offered by the TL2218-285 is a design that does not require costly laser trimming in the manufacturing process.

The TL2218-285 is characterized for operation over the virtual junction temperature range of 0°C to 125°C.

<sup>†</sup> This symbol is not presently listed within EIA/JEDEC standards for letter symbols.

# TL2218-285, TL2218-285Y EXCALIBUR CURRENT-MODE SCSI TERMINATOR

SLVS072C – DECEMBER 1992 – REVISED OCTOBER 1995

## AVAILABLE OPTIONS

T <sub>J</sub>	SURFACE MOUNT (PW) <sup>†</sup>	CHIP FORM (Y)
0°C to 125°C	TL2218-285PWLE	TL2218-285Y

<sup>†</sup> The PW package is only available left-end taped and reeled.

## TL2218-285Y chip information

This chip, when properly assembled, displays characteristics similar to the TL2218-285. Thermal compression or ultrasonic bonding may be used on the doped aluminum bonding pads. The chip may be mounted with conductive epoxy or a gold-silicon preform.

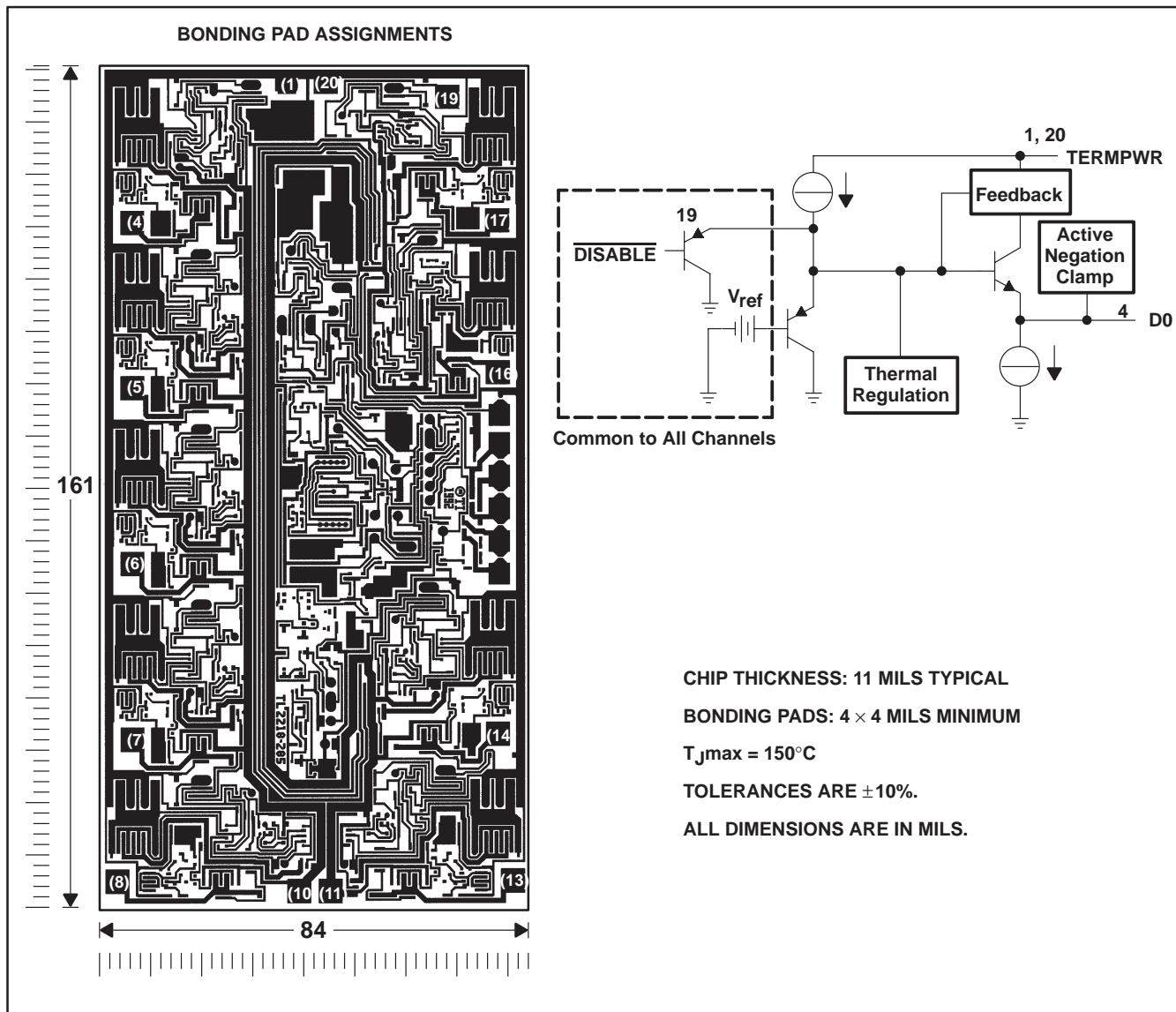

# TL2218-285, TL2218-285Y EXCALIBUR CURRENT-MODE SCSI TERMINATOR

SLVS072C – DECEMBER 1992 – REVISED OCTOBER 1995

## functional block diagram (each channel)

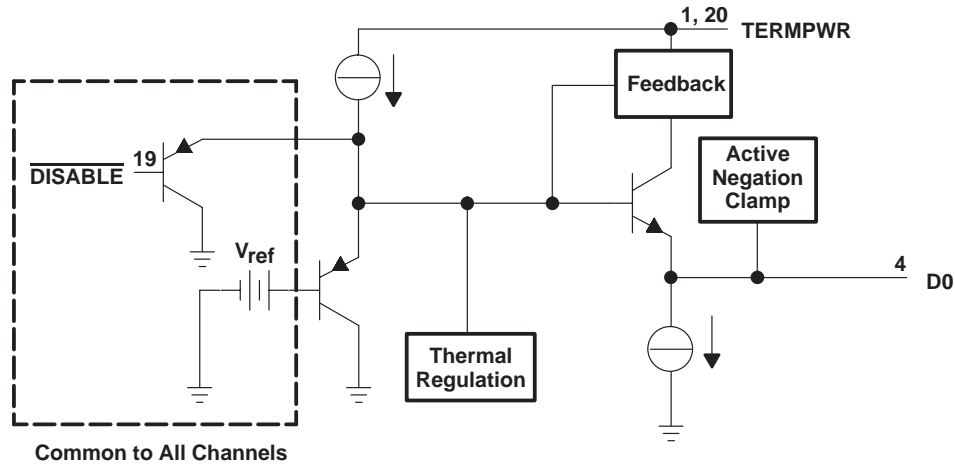

## absolute maximum ratings over operating free-air temperature range (unless otherwise noted) (see Figures 1, 2, and 3)<sup>†</sup>

Continuous termination voltage .....	10 V
Continuous output voltage range .....	0 V to 5.5 V
Continuous disable voltage range .....	0 V to 5.5 V
Continuous total power dissipation .....	See Dissipation Rating Table
Operating virtual junction temperature range, $T_J$ .....	-55°C to 150°C
Storage temperature range, $T_{stg}$ .....	-60°C to 150°C
Lead temperature 1,6 mm (1/16 inch) from case for 10 seconds .....	260°C

<sup>†</sup> Stresses beyond those listed under "absolute maximum ratings" may cause permanent damage to the device. These are stress ratings only, and functional operation of the device at these or any other conditions beyond those indicated under "recommended operating conditions" is not implied. Exposure to absolute-maximum-rated conditions for extended periods may affect device reliability.

**DISSIPATION RATING TABLE**

PACKAGE	POWER RATING AT	$T \leq 25^\circ\text{C}$	DERATING FACTOR	$T = 70^\circ\text{C}$	$T = 85^\circ\text{C}$	$T = 125^\circ\text{C}$
		POWER RATING	ABOVE $T = 25^\circ\text{C}$	POWER RATING	POWER RATING	POWER RATING
PW	$T_A$	828 mW	6.62 mW/°C	530 mW	430 mW	166 mW
	$T_C$	4032 mW	32.2 mW/°C	2583 mW	2100 mW	812 mW
	$T_L^\ddagger$	2475 mW	19.8 mW/°C	1584 mW	1287 mW	495 mW

<sup>‡</sup>  $R_{\theta JL}$  is the thermal resistance between the junction and device lead. To determine the virtual junction temperature ( $T_J$ ) relative to the device lead temperature, the following calculations should be used:  $T_J = P_D \times R_{\theta JL} + T_L$ , where  $P_D$  is the internal power dissipation of the device and  $T_L$  is the device lead temperature at the point of contact to the printed wiring board.  $R_{\theta JL}$  is 50.5°C/W.

# TL2218-285, TL2218-285Y EXCALIBUR CURRENT-MODE SCSI TERMINATOR

SLVS072C – DECEMBER 1992 – REVISED OCTOBER 1995

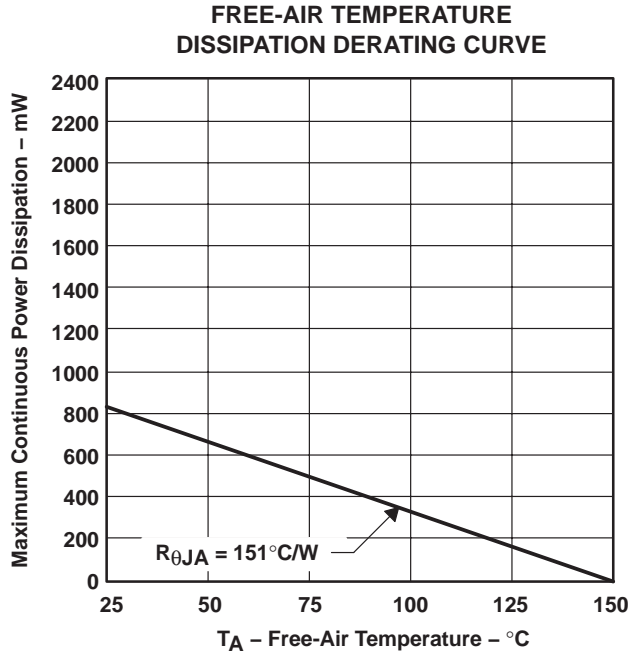

Figure 1

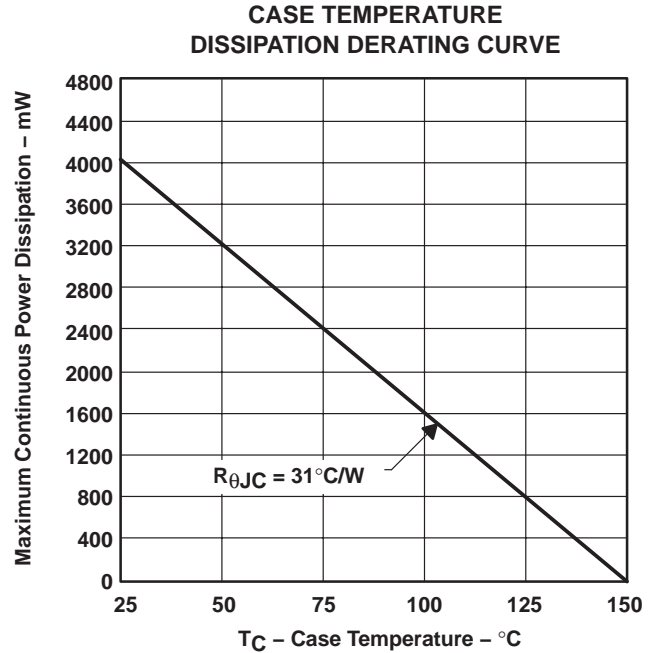

Figure 2

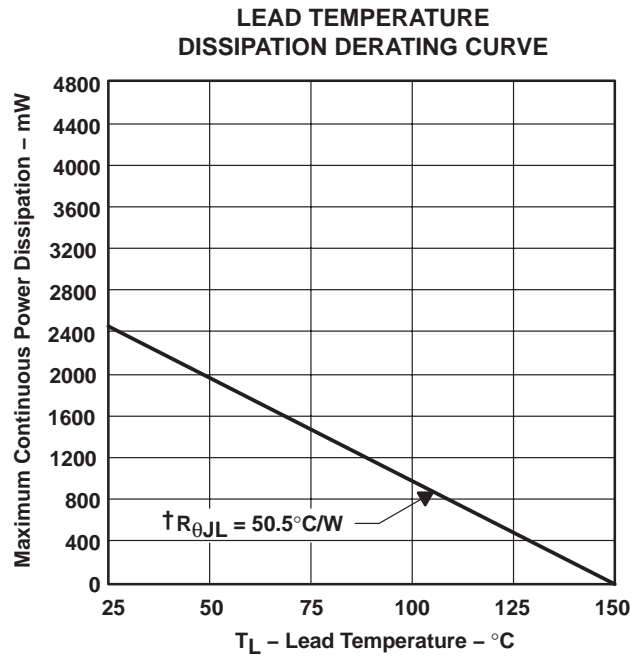

Figure 3

†  $R_{\theta JL}$  is the thermal resistance between the junction and device lead. To determine the virtual junction temperature ( $T_J$ ) relative to the device lead temperature, the following calculations should be used:  $T_J = P_D \times R_{\theta JL} + T_L$ , where  $P_D$  is the internal power dissipation of the device, and  $T_L$  is the device lead temperature at the point of contact to the printed wiring board.  $R_{\theta JL}$  is 50.5°C/W.

# TL2218-285, TL2218-285Y EXCALIBUR CURRENT-MODE SCSI TERMINATOR

SLVS072C – DECEMBER 1992 – REVISED OCTOBER 1995

## recommended operating conditions

	MIN	MAX	UNIT
Termination voltage	3.5	5.5	V
High-level disable input voltage, $V_{IH}$	2	$V_{term}$	V
Low-level disable input voltage, $V_{IL}$	0	0.8	V
Operating virtual junction temperature, $T_J$	0	125	°C

## electrical characteristics, $V_{term} = 4.75\text{ V}$ , $V_O = 0.5\text{ V}$ , $T_J = 25^\circ\text{C}$

PARAMETER	TEST CONDITIONS	MIN	TYP	MAX	UNIT
Output high voltage		2.5	2.85		V
TERMPWR supply current	All data lines open		9		mA
	All data lines = 0.5 V		228		
	$\overline{\text{DISABLE}} = 0\text{ V}$		500		$\mu\text{A}$
Output current		-20.5	-23	-24	mA
Disable input current (see Note 1)	$\overline{\text{DISABLE}} = 4.75\text{ V}$			1	$\mu\text{A}$
	$\overline{\text{DISABLE}} = 0\text{ V}$			600	
Output leakage current	$\overline{\text{DISABLE}} = 0\text{ V}$		100		nA
Output capacitance, device disabled	$V_O = 0\text{ V}$ , 1 MHz		6		pF
Termination sink current, total	$V_O = 4\text{ V}$		20		mA

NOTE 1: When  $\overline{\text{DISABLE}}$  is open or high, the terminator is active.



# TL2218-285, TL2218-285Y EXCALIBUR CURRENT-MODE SCSI TERMINATOR

SLVS072C – DECEMBER 1992 – REVISED OCTOBER 1995

## THERMAL INFORMATION

The need for smaller surface-mount packages for use on compact printed-wiring boards (PWB) causes an increasingly difficult problem in the area of thermal dissipation. In order to provide the systems designer with a better approximation of the junction temperature rise in the thin-shrink small-outline package (TSSOP), the junction-to-lead thermal resistance ( $R_{\theta JL}$ ) is provided along with the more typical values of junction-to-ambient and junction-to-case thermal resistances,  $R_{\theta JA}$  and  $R_{\theta JC}$ .

$R_{\theta JL}$  is used to calculate the device junction temperature rise measured from the leads of the unit. Consequently, the junction temperature is dependent upon the board temperature at the leads,  $R_{\theta JL}$ , and the internal power dissipation of the device. The board temperature is contingent upon several variables, including device packing density, thickness, material, area, and number of interconnects. The  $R_{\theta JL}$  value depends on the number of leads connecting to the die-mount pad, the lead-frame alloy, area of the die, mount material, and mold compound. Since the power level at which the TSSOP can be used is highly dependent upon both the temperature rise of the PWB and the device itself, the systems designer can maximize this level by optimizing the circuit board. The junction temperature of the device can be calculated using the equation  $T_J = (P_D \times R_{\theta JL}) + T_L$  where  $T_J$  = junction temperature,  $P_D$  = power dissipation,  $R_{\theta JL}$  = junction-to-lead thermal resistance, and  $T_L$  = board temperature at the leads of the unit.

The values of thermal resistance for the TL2218-285 PW are as follows:

Thermal Resistance	Typical Junction Rise
$R_{\theta JA}$	151°C/W
$R_{\theta JC}$	31 °C/W
$R_{\theta JL}$	50.5°C/W

## TYPICAL CHARACTERISTICS

Table of Graphs

			FIGURE
$I_O$	Output current	vs Input voltage	4
$V_O$	Output voltage	vs Input voltage	5
$I_O$	Output current	vs Junction temperature	6
$V_O$	Output voltage	vs Junction temperature	7

TYPICAL CHARACTERISTICS

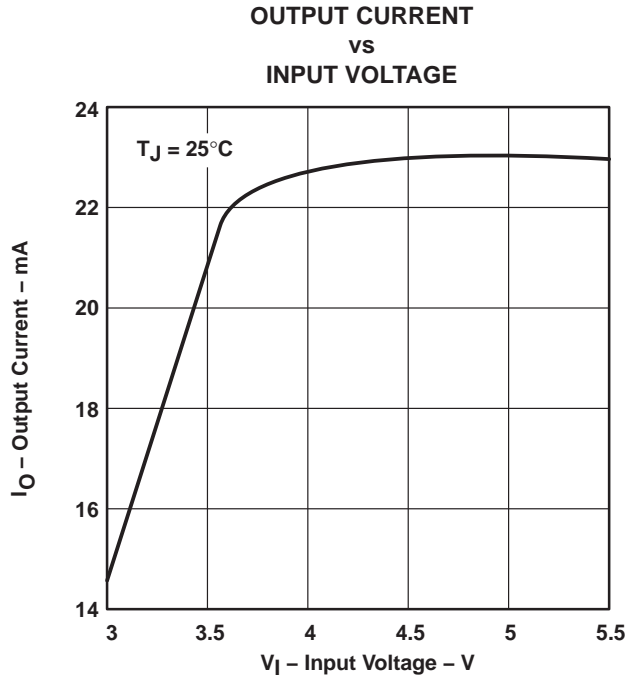

Figure 4

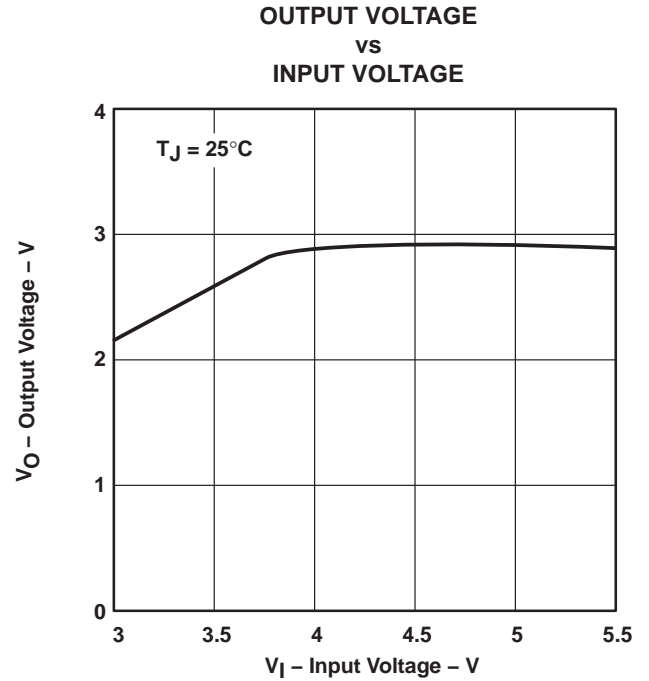

Figure 5

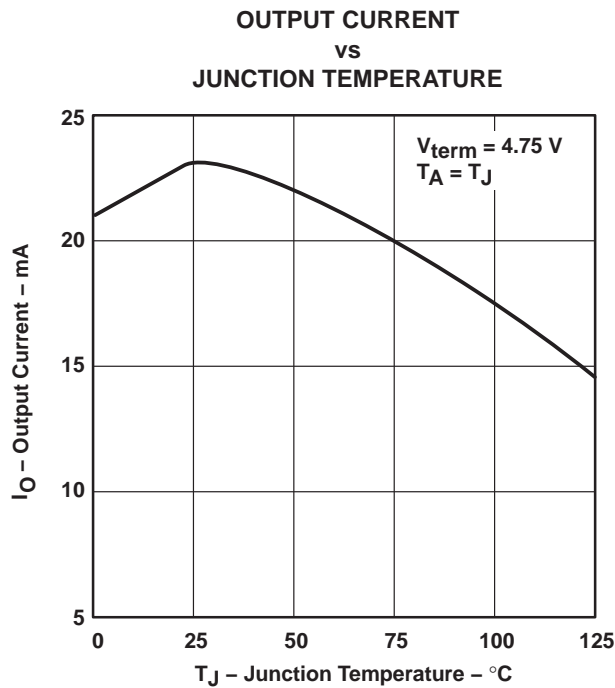

Figure 6

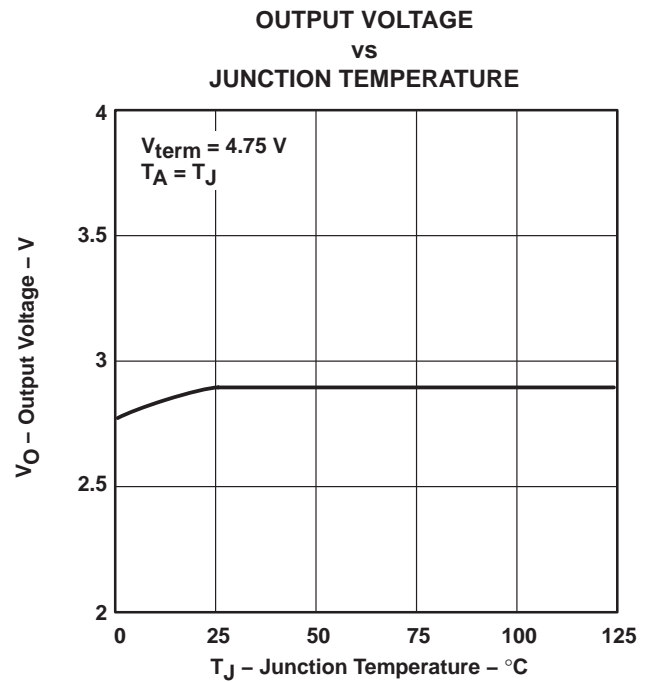

Figure 7





**PACKAGING INFORMATION**

Orderable Device	Status (1)	Package Type	Package Drawing	Pins	Package Qty	Eco Plan (2)	Lead/Ball Finish (6)	MSL Peak Temp (3)	Op Temp (°C)	Device Marking (4/5)	Samples
TL2218-285PW	ACTIVE	TSSOP	PW	20	70	Green (RoHS & no Sb/Br)	CU NIPDAU	Level-1-260C-UNLIM	0 to 125	2218285	<a href="#">Samples</a>
TL2218-285PWR	ACTIVE	TSSOP	PW	20	2000	Green (RoHS & no Sb/Br)	CU NIPDAU	Level-1-260C-UNLIM	0 to 125	2218285	<a href="#">Samples</a>

(1) The marketing status values are defined as follows:

**ACTIVE:** Product device recommended for new designs.

**LIFEBUY:** TI has announced that the device will be discontinued, and a lifetime-buy period is in effect.

**NRND:** Not recommended for new designs. Device is in production to support existing customers, but TI does not recommend using this part in a new design.

**PREVIEW:** Device has been announced but is not in production. Samples may or may not be available.

**OBsolete:** TI has discontinued the production of the device.

(2) **RoHS:** TI defines "RoHS" to mean semiconductor products that are compliant with the current EU RoHS requirements for all 10 RoHS substances, including the requirement that RoHS substance do not exceed 0.1% by weight in homogeneous materials. Where designed to be soldered at high temperatures, "RoHS" products are suitable for use in specified lead-free processes. TI may reference these types of products as "Pb-Free".

**RoHS Exempt:** TI defines "RoHS Exempt" to mean products that contain lead but are compliant with EU RoHS pursuant to a specific EU RoHS exemption.

**Green:** TI defines "Green" to mean the content of Chlorine (Cl) and Bromine (Br) based flame retardants meet JS709B low halogen requirements of <=1000ppm threshold. Antimony trioxide based flame retardants must also meet the <=1000ppm threshold requirement.

(3) MSL, Peak Temp. - The Moisture Sensitivity Level rating according to the JEDEC industry standard classifications, and peak solder temperature.

(4) There may be additional marking, which relates to the logo, the lot trace code information, or the environmental category on the device.

(5) Multiple Device Markings will be inside parentheses. Only one Device Marking contained in parentheses and separated by a "-" will appear on a device. If a line is indented then it is a continuation of the previous line and the two combined represent the entire Device Marking for that device.

(6) Lead/Ball Finish - Orderable Devices may have multiple material finish options. Finish options are separated by a vertical ruled line. Lead/Ball Finish values may wrap to two lines if the finish value exceeds the maximum column width.

**Important Information and Disclaimer:**The information provided on this page represents TI's knowledge and belief as of the date that it is provided. TI bases its knowledge and belief on information provided by third parties, and makes no representation or warranty as to the accuracy of such information. Efforts are underway to better integrate information from third parties. TI has taken and continues to take reasonable steps to provide representative and accurate information but may not have conducted destructive testing or chemical analysis on incoming materials and chemicals. TI and TI suppliers consider certain information to be proprietary, and thus CAS numbers and other limited information may not be available for release.

In no event shall TI's liability arising out of such information exceed the total purchase price of the TI part(s) at issue in this document sold by TI to Customer on an annual basis.



**TAPE AND REEL INFORMATION**
**REEL DIMENSIONS**

**TAPE DIMENSIONS**

A0	Dimension designed to accommodate the component width
B0	Dimension designed to accommodate the component length
K0	Dimension designed to accommodate the component thickness
W	Overall width of the carrier tape
P1	Pitch between successive cavity centers

**TAPE AND REEL INFORMATION**

\*All dimensions are nominal

Device	Package Type	Package Drawing	Pins	SPQ	Reel Diameter (mm)	Reel Width W1 (mm)	A0 (mm)	B0 (mm)	K0 (mm)	P1 (mm)	W (mm)	Pin1 Quadrant
TL2218-285PWR	TSSOP	PW	20	2000	330.0	16.4	6.95	7.1	1.6	8.0	16.0	Q1

**TAPE AND REEL BOX DIMENSIONS**



\*All dimensions are nominal

Device	Package Type	Package Drawing	Pins	SPQ	Length (mm)	Width (mm)	Height (mm)
TL2218-285PWR	TSSOP	PW	20	2000	367.0	367.0	38.0

## IMPORTANT NOTICE

Texas Instruments Incorporated (TI) reserves the right to make corrections, enhancements, improvements and other changes to its semiconductor products and services per JESD46, latest issue, and to discontinue any product or service per JESD48, latest issue. Buyers should obtain the latest relevant information before placing orders and should verify that such information is current and complete.

TI's published terms of sale for semiconductor products (<http://www.ti.com/sc/docs/stdterms.htm>) apply to the sale of packaged integrated circuit products that TI has qualified and released to market. Additional terms may apply to the use or sale of other types of TI products and services.

Reproduction of significant portions of TI information in TI data sheets is permissible only if reproduction is without alteration and is accompanied by all associated warranties, conditions, limitations, and notices. TI is not responsible or liable for such reproduced documentation. Information of third parties may be subject to additional restrictions. Resale of TI products or services with statements different from or beyond the parameters stated by TI for that product or service voids all express and any implied warranties for the associated TI product or service and is an unfair and deceptive business practice. TI is not responsible or liable for any such statements.

Buyers and others who are developing systems that incorporate TI products (collectively, "Designers") understand and agree that Designers remain responsible for using their independent analysis, evaluation and judgment in designing their applications and that Designers have full and exclusive responsibility to assure the safety of Designers' applications and compliance of their applications (and of all TI products used in or for Designers' applications) with all applicable regulations, laws and other applicable requirements. Designer represents that, with respect to their applications, Designer has all the necessary expertise to create and implement safeguards that (1) anticipate dangerous consequences of failures, (2) monitor failures and their consequences, and (3) lessen the likelihood of failures that might cause harm and take appropriate actions. Designer agrees that prior to using or distributing any applications that include TI products, Designer will thoroughly test such applications and the functionality of such TI products as used in such applications.

TI's provision of technical, application or other design advice, quality characterization, reliability data or other services or information, including, but not limited to, reference designs and materials relating to evaluation modules, (collectively, "TI Resources") are intended to assist designers who are developing applications that incorporate TI products; by downloading, accessing or using TI Resources in any way, Designer (individually or, if Designer is acting on behalf of a company, Designer's company) agrees to use any particular TI Resource solely for this purpose and subject to the terms of this Notice.

TI's provision of TI Resources does not expand or otherwise alter TI's applicable published warranties or warranty disclaimers for TI products, and no additional obligations or liabilities arise from TI providing such TI Resources. TI reserves the right to make corrections, enhancements, improvements and other changes to its TI Resources. TI has not conducted any testing other than that specifically described in the published documentation for a particular TI Resource.

Designer is authorized to use, copy and modify any individual TI Resource only in connection with the development of applications that include the TI product(s) identified in such TI Resource. NO OTHER LICENSE, EXPRESS OR IMPLIED, BY ESTOPPEL OR OTHERWISE TO ANY OTHER TI INTELLECTUAL PROPERTY RIGHT, AND NO LICENSE TO ANY TECHNOLOGY OR INTELLECTUAL PROPERTY RIGHT OF TI OR ANY THIRD PARTY IS GRANTED HEREIN, including but not limited to any patent right, copyright, mask work right, or other intellectual property right relating to any combination, machine, or process in which TI products or services are used. Information regarding or referencing third-party products or services does not constitute a license to use such products or services, or a warranty or endorsement thereof. Use of TI Resources may require a license from a third party under the patents or other intellectual property of the third party, or a license from TI under the patents or other intellectual property of TI.

TI RESOURCES ARE PROVIDED "AS IS" AND WITH ALL FAULTS. TI DISCLAIMS ALL OTHER WARRANTIES OR REPRESENTATIONS, EXPRESS OR IMPLIED, REGARDING RESOURCES OR USE THEREOF, INCLUDING BUT NOT LIMITED TO ACCURACY OR COMPLETENESS, TITLE, ANY EPIDEMIC FAILURE WARRANTY AND ANY IMPLIED WARRANTIES OF MERCHANTABILITY, FITNESS FOR A PARTICULAR PURPOSE, AND NON-INFRINGEMENT OF ANY THIRD PARTY INTELLECTUAL PROPERTY RIGHTS. TI SHALL NOT BE LIABLE FOR AND SHALL NOT DEFEND OR INDEMNIFY DESIGNER AGAINST ANY CLAIM, INCLUDING BUT NOT LIMITED TO ANY INFRINGEMENT CLAIM THAT RELATES TO OR IS BASED ON ANY COMBINATION OF PRODUCTS EVEN IF DESCRIBED IN TI RESOURCES OR OTHERWISE. IN NO EVENT SHALL TI BE LIABLE FOR ANY ACTUAL, DIRECT, SPECIAL, COLLATERAL, INDIRECT, PUNITIVE, INCIDENTAL, CONSEQUENTIAL OR EXEMPLARY DAMAGES IN CONNECTION WITH OR ARISING OUT OF TI RESOURCES OR USE THEREOF, AND REGARDLESS OF WHETHER TI HAS BEEN ADVISED OF THE POSSIBILITY OF SUCH DAMAGES.

Unless TI has explicitly designated an individual product as meeting the requirements of a particular industry standard (e.g., ISO/TS 16949 and ISO 26262), TI is not responsible for any failure to meet such industry standard requirements.

Where TI specifically promotes products as facilitating functional safety or as compliant with industry functional safety standards, such products are intended to help enable customers to design and create their own applications that meet applicable functional safety standards and requirements. Using products in an application does not by itself establish any safety features in the application. Designers must ensure compliance with safety-related requirements and standards applicable to their applications. Designer may not use any TI products in life-critical medical equipment unless authorized officers of the parties have executed a special contract specifically governing such use. Life-critical medical equipment is medical equipment where failure of such equipment would cause serious bodily injury or death (e.g., life support, pacemakers, defibrillators, heart pumps, neurostimulators, and implantables). Such equipment includes, without limitation, all medical devices identified by the U.S. Food and Drug Administration as Class III devices and equivalent classifications outside the U.S.

TI may expressly designate certain products as completing a particular qualification (e.g., Q100, Military Grade, or Enhanced Product). Designers agree that it has the necessary expertise to select the product with the appropriate qualification designation for their applications and that proper product selection is at Designers' own risk. Designers are solely responsible for compliance with all legal and regulatory requirements in connection with such selection.

Designer will fully indemnify TI and its representatives against any damages, costs, losses, and/or liabilities arising out of Designer's non-compliance with the terms and provisions of this Notice.