



**Micro Commercial Components**

Micro Commercial Components  
 20736 Marilla Street Chatsworth  
 CA 91311  
 Phone: (818) 701-4933  
 Fax: (818) 701-4939

# TL431AU

## Features

- Programmable Output Voltage 36V
- Sink Current Capability of 0.1mA to 100 mA
- Temperature Compensated for operation over full rated operating temperature range
- Low output noise voltage and Fast turn on response
- The Reference Input Voltage tolerance is 1%
- Marking Code: 431

## Programmable Precision Regulator

### Maximum Ratings

Parameter	Symbol	Value	Unit
Cathode Voltage	$V_{KA}$	37	V
Cathode Current Range	$I_K$	-100~150	mA
Reference Input Current Range	$I_{REF}$	0.05~10	mA
Power Dissipation at 25°C	$P_D$	0.2	W
Thermal Resistance Junction to Ambient	$R_{\theta JA}$	300	°C/W
Junction Temperature	$T_J$	0~150	°C
Operating Temperature	$T_g$	0~70	°C
Storage Temperature Range	$T_{STG}$	-55~+150	°C

### Recommended Operating Conditions

Parameter	Sym	Min	Max	Unit
Cathode Voltage	$V_{KA}$	$V_{REF}$	36	V
Cathode Current Range	$I_K$	1.0	100	mA

### Electrical Characteristics @ 25°C Unless Otherwise Specified

Parameter	Sym	Min	Typ	Max	Test conditions
Reference Input Voltage	$V_{ref}$	2.475V	2.500V	2.525V	
Deviation of reference input voltage	$V_{ref(dev)}$		3.0mV	17mV	$T_{min} \leq T_a \leq T_{max}$
Ratio of Change in Reference Input Voltage to the Change in Cathode Voltage	$\frac{\Delta V_{ref}}{\Delta V_{KA}}$		-1.4	-2.7	$\Delta V_{KA}=10V \sim V_{ref}$
Reference Input Current	$I_{ref}$		1.8μA	4.0μA	$I_{KA}=10mA, R_1=10K\Omega, R_2=\infty$
Deviation of Reference Input Current Over Full Temperature Range	$\frac{\Delta I_{ref}}{\Delta T}$		0.4μA	1.2μA	$I_{KA}=10mA, R_1=10K\Omega, R_2=\infty, T_A=full\ Temperature$
Minimum Cathode Current for Regulation	$I_{KA(min)}$		0.5mA	1.0mA	
Off-State Cathode Current	$I_{KA(off)}$		0.26μA	1.0μA	$V_{KA}=36V, V_{REF}=0V$
Dynamic Impedance	$Z_{KA}$		0.22Ω	0.5Ω	$I_{KA}=10\ to\ 100mA, f \leq 1.0KHz$

### SOT-23

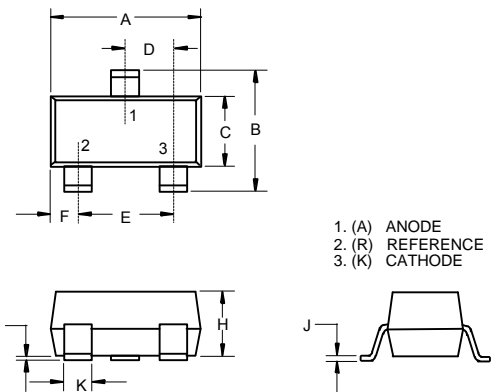

DIM	INCHES		MM		NOTE
	MIN	MAX	MIN	MAX	
A	.110	.120	2.80	3.04	
B	.083	.098	2.10	2.64	
C	.047	.055	1.20	1.40	
D	.035	.041	.89	1.03	
E	.070	.081	1.78	2.05	
F	.018	.024	.45	.60	
G	.0005	.0039	.013	.100	
H	.035	.044	.89	1.12	
J	.003	.007	.085	.180	
K	.015	.020	.37	.51	

### Suggested Solder Pad Layout

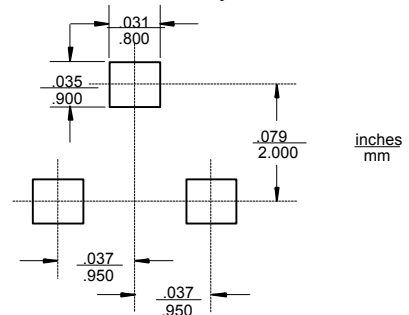

TL431AU

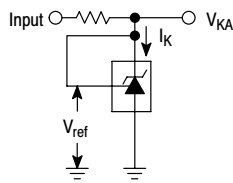

Figure 1. Test Circuit for  $V_{KA} = V_{ref}$

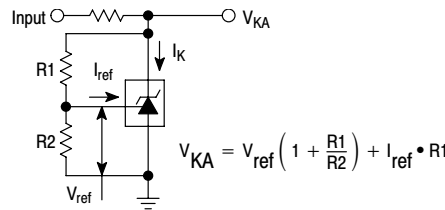

Figure 2. Test Circuit for  $V_{KA} > V_{ref}$

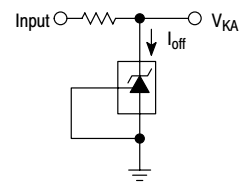

Figure 3. Test Circuit for  $I_{off}$

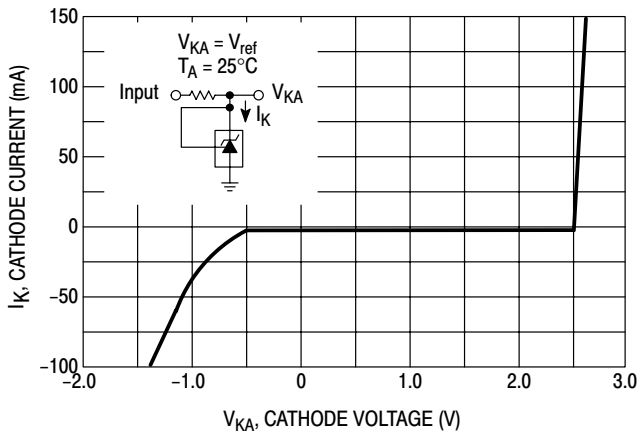

Figure 4. Cathode Current versus Cathode Voltage

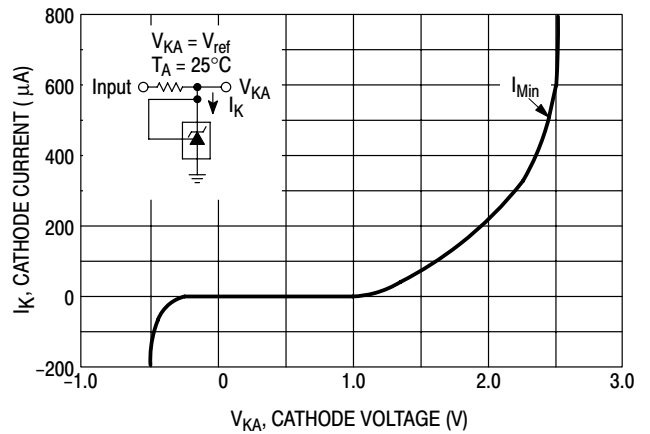

Figure 5. Cathode Current versus Cathode Voltage

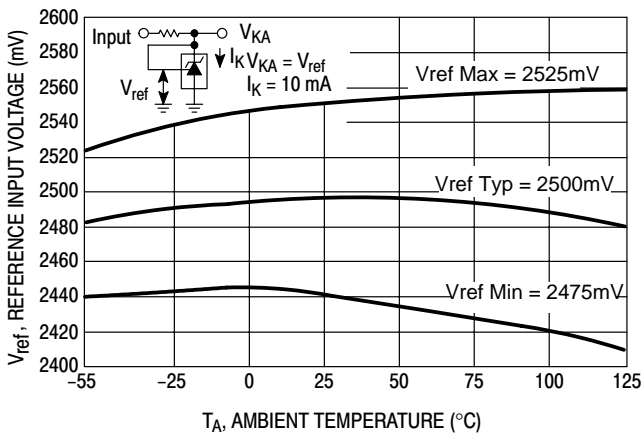

Figure 6. Reference Input Voltage versus Ambient Temperature

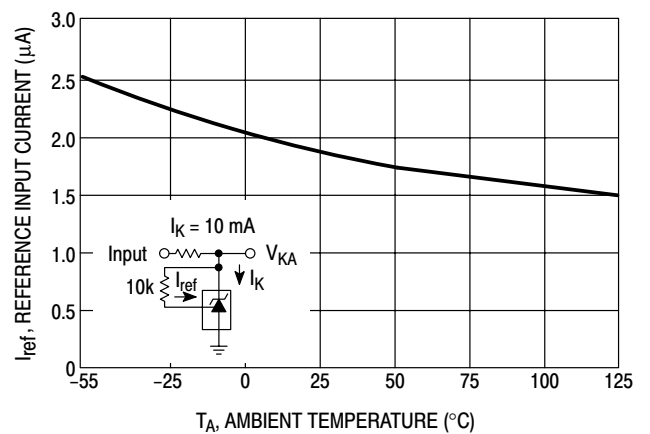

Figure 7. Reference Input Current versus Ambient Temperature

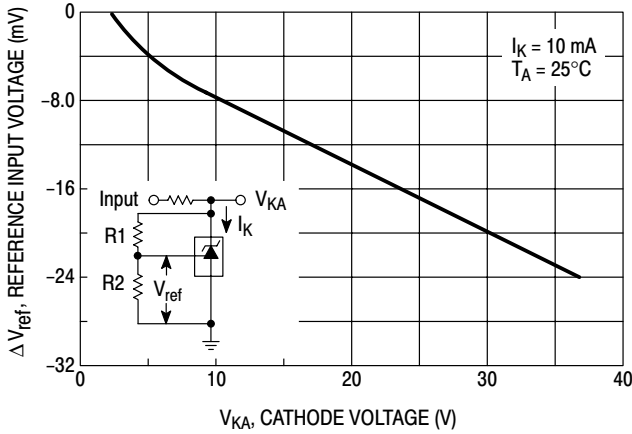

Figure 8. Change in Reference Input Voltage versus Cathode Voltage

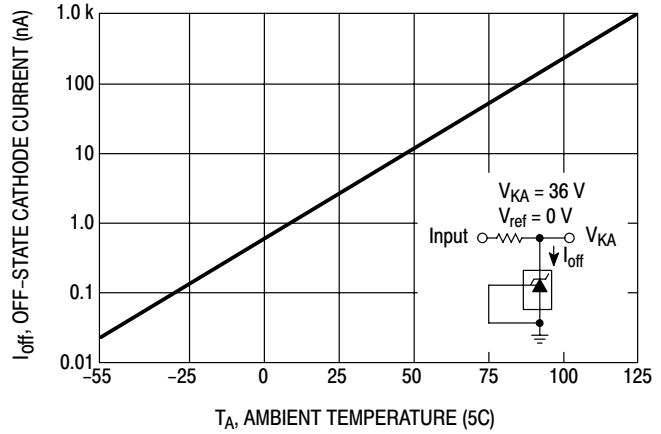

Figure 9. Off-State Cathode Current versus Ambient Temperature

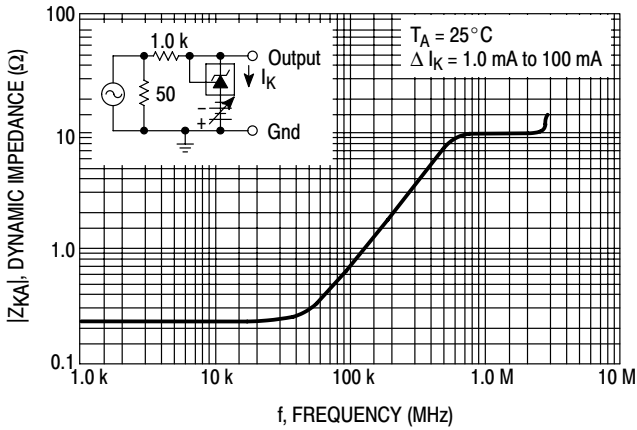

Figure 10. Dynamic Impedance versus Frequency

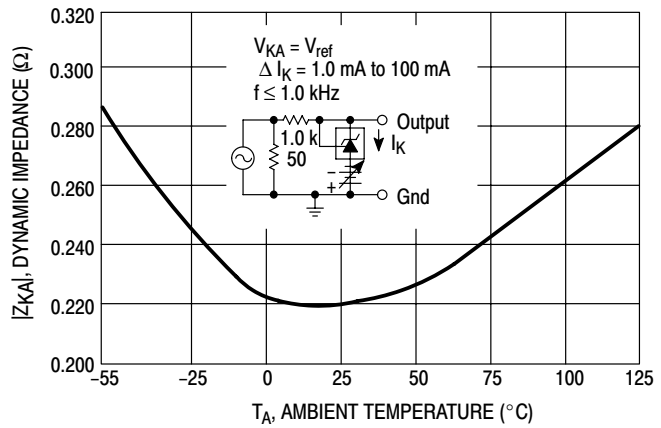

Figure 11. Dynamic Impedance versus Ambient Temperature

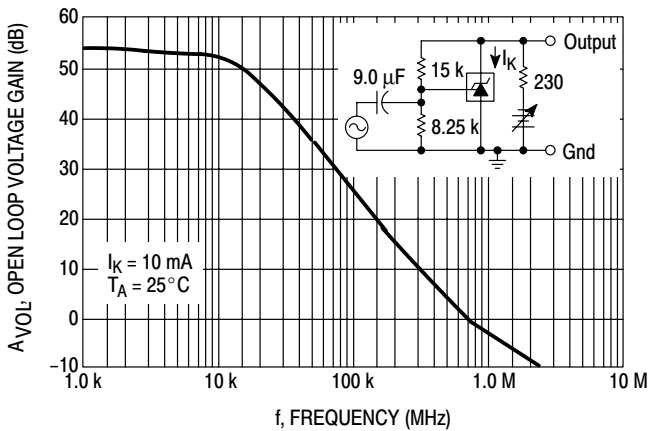

Figure 12. Open-Loop Voltage Gain versus Frequency

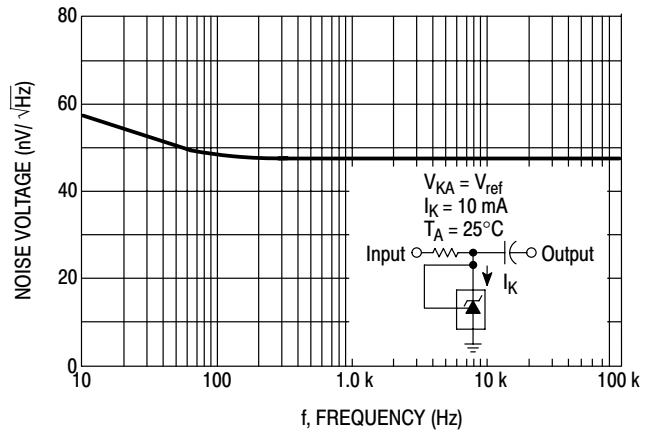

Figure 13. Spectral Noise Density