

描述 / Descriptions

SOT-23 塑封封装精密可调基准电源。

Precision adjustable shunt regulator in a SOT-23 Plastic Package.

特征 / Features

精确参照电压 2.495V;允许电压误差为 0.5%,1%或 2%;阴极电流能力为 1.0mA ~ 100mA;快速导通;可调节输出电压为 $V_O=V_{ref} \sim 36V$;阴极工作电流低(典型值:50 μ A);动态输出阻抗低(典型值:0.15 Ω)。

Precise reference voltage to 2.495V;guaranteed 0.5%,1% or 2% reference voltage Tolerance; sink current capability,1.0mA~100mA;quick turn-on; adjustable Output voltage, $V_O=V_{ref} \sim 36V$;low operational cathode current,50 μ A typical; 0.15 Ω typical output impedance.

用途 / Applications

用于线性调整器,可调节电源和开关电源。

Linear regulators, adjustable power supply, switching power supply.

内部等效电路 / Equivalent Circuit

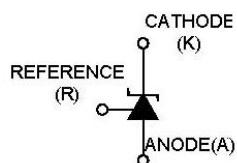

引脚排列 / Pinning



PIN 1 : R

PIN 2 : K

PIN 3 : A

放大及印章代码 / h_{FE} Classifications & Marking

Marking	H431
---------	------

极限参数 / Absolute Maximum Ratings(Ta=25°C)

参数 Parameter	符号 Symbol	数值 Rating	单位 Unit
Cathode to Anode Voltage	V_{KA}	37	V
Cathode Current Range, Continuous	I_K	-100~+100	mA
Reference Input Current Range, Continuous	I_{REF}	0.05~+10	mA
Power Dissipation	P_D	370	mW
Operating Ambient Temperature	T_{amb}	-40~125	°C
Junction Temperature	T_j	150	°C
Storage Temperature Range	T_{stg}	-65~150	°C

电性能参数 / Electrical Characteristics(Ta=25°C)

参数 Parameter	符号 Symbol	测试条件 Test Conditions	最小值 Min	典型值 Typ	最大值 Max	单位 Unit
Reference Input Voltage	V_{REF}	$V_{KA}=V_{REF}$ $I_K=10mA(A=0.5\%)$	2.483	2.495	2.507	V
		$V_{KA}=V_{REF}$ $I_K=10mA(B=1\%)$	2.470	2.495	2.520	V
		$V_{KA}=V_{REF}$ $I_K=10mA(2\%)$	2.445	2.495	2.545	V
Deviation of Reference Input Voltage Over-Temperature	$\Delta V_{REF}/\Delta T$	$V_{KA}=V_{REF}$ $I_K=10mA$ $T_A=-40\sim 125^\circ C$		4.5	25	mV
Ratio of Change in Reference Input Voltage to the Change in Cathode Voltage	$\Delta V_{REF}/\Delta V_{KA}$	$I_K=10mA,$ $\Delta V_{KA}=10V$ to V_{REF}		-1	-2.7	mV/V
		$I_K=10mA,$ $\Delta V_{KA}=36V$ to $10V$		-0.5	-2.0	mV/V
Reference Input Current	I_{REF}	$I_K=10mA$ $R_1=10K\Omega$ $R_2=open$		0.8	1.0	μA
Deviation of Reference Input Current Over Full Temperature Range	$\Delta I_{REF}/\Delta T$	$I_K=10mA$ $R_1=10K\Omega$ $R_2=open$ $T_A=-40\sim 125^\circ C$		0.4	1.2	μA
Minimum Cathode Current for Regulation	$I_{K(min)}$	$V_{KA}=V_{REF}$		0.05	0.08	mA
Off-state cathode current	$I_{K(off)}$	$V_{KA}=36V$ $V_{REF}=0V$		0.05	1.0	μA
Dynamic Impedance	$ Z_{KA} $	$V_{KA}=V_{REF}$ $f\leq 1.0KHz$ $I_K=1mA$ to $100mA$		0.15	0.5	Ω

电参数曲线图 / Electrical Characteristic Curve

Fig 1 Cathode Current Vs Cathode Voltage

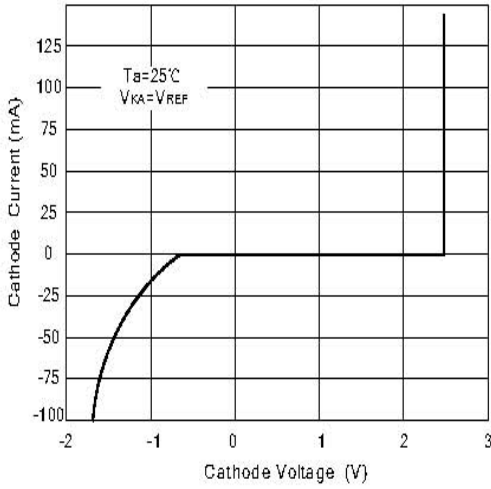

Fig 2 Cathode Current Vs Cathode Voltage

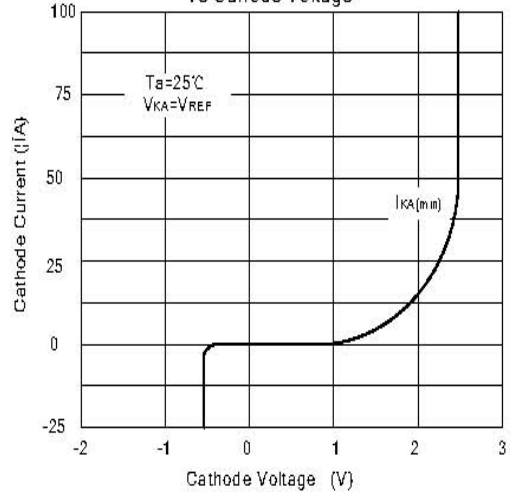

Fig 3 Change in Reference Input Voltage Vs Cathode voltage

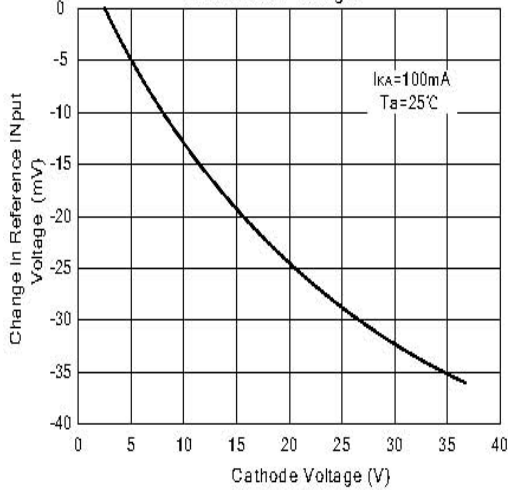

Fig 4 Pulse Response

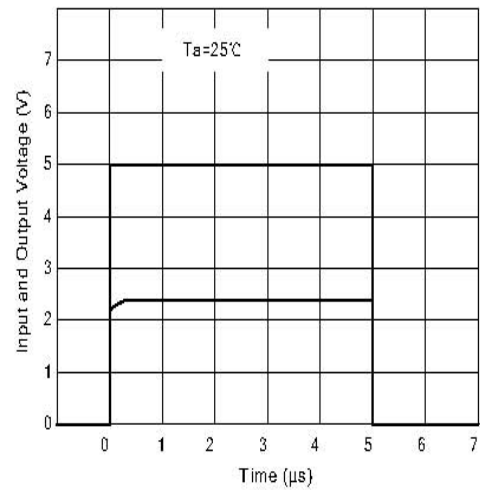

Fig 5 Dynamic Impedance Vs Frequency

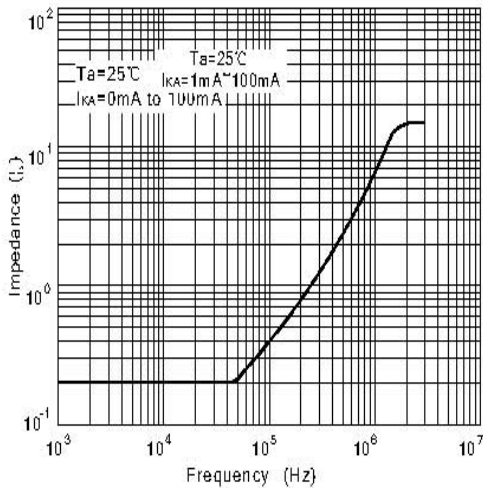
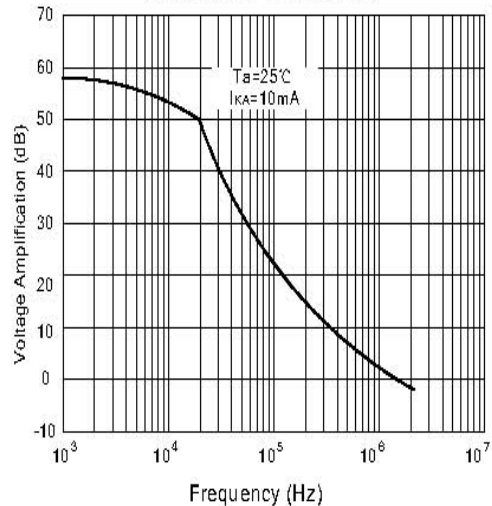
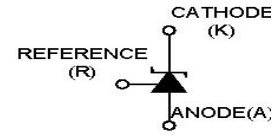
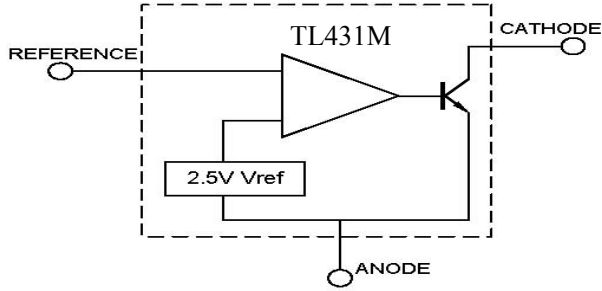

Fig 6 Small Signal Voltage Amplification Vs Frequency



测试电路图&典型应用图 Test circuits&Typical Application

BLOCK DIAGRAM:



TEST CIRCUITS:

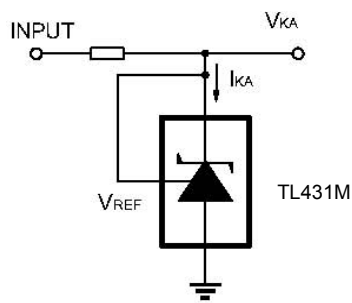

Test Circuit For $V_{KA} = V_{REF}$

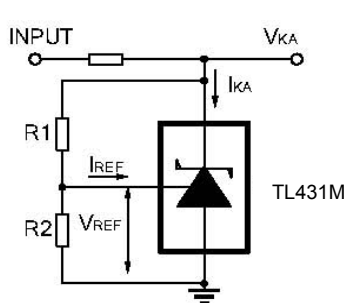

$V_{KA} = V_{REF} * (1 + R1/R2) + I_{REF} * R1$
Test Circuit for $V_{KA} \geq V_{REF}$

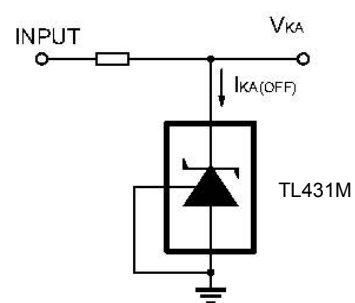

Test Circuit For $I_{KA(OFF)}$

TYPICAL APPLICATION:

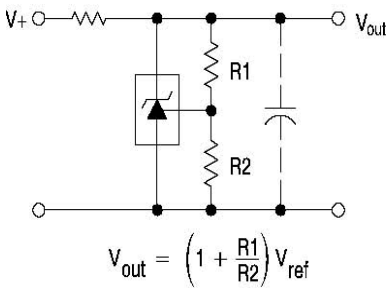

Shutdown Regulator
 $V_{out} = \left(1 + \frac{R1}{R2}\right) V_{ref}$

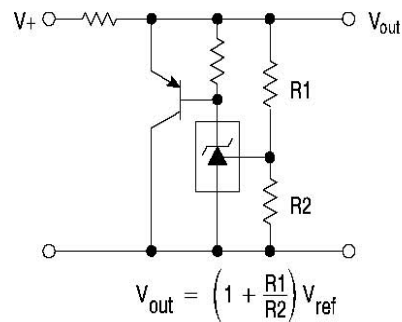

Higher-current Shunt
 $V_{out} = \left(1 + \frac{R1}{R2}\right) V_{ref}$

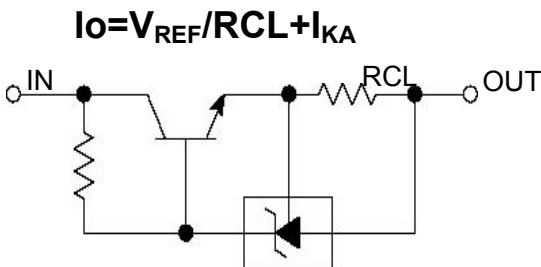

Constant Current Source
 $I_o = V_{REF}/R_{CL} + I_{KA}$
TL431M

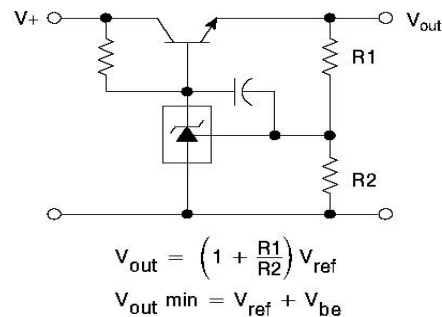

Series Pass Regulator
 $V_{out} = \left(1 + \frac{R1}{R2}\right) V_{ref}$
 $V_{out\ min} = V_{ref} + V_{be}$

外形尺寸图 / Package Dimensions

SOT-23

单位: mm

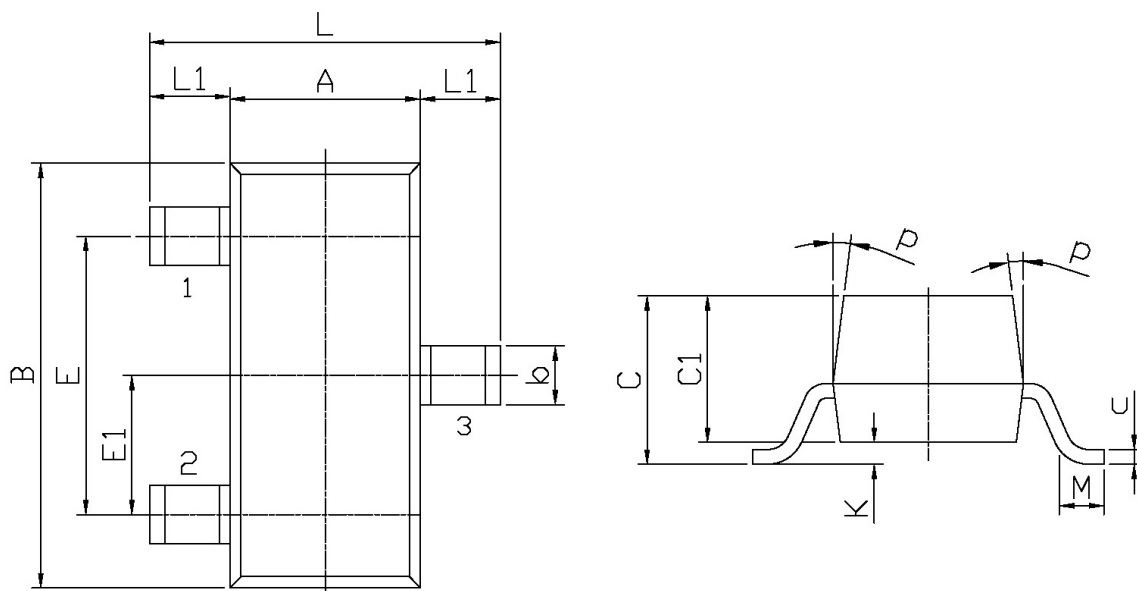

Symbol	Dimensions In Millimeters		Symbol	Dimensions In Millimeters	
	Min	Max		Min	Max
L	2.2	2.7	C	1.30Max	
L1	0.45	0.65	C1	0.90	1.20
A	1.15	1.50	c	0.05	0.20
B	2.70	3.10	K	0	0.10
E	1.70	2.10	M	0.20MIN	
E1	0.85	1.05	P	7°	
b	0.35	0.55			

印章说明 / Marking Instructions

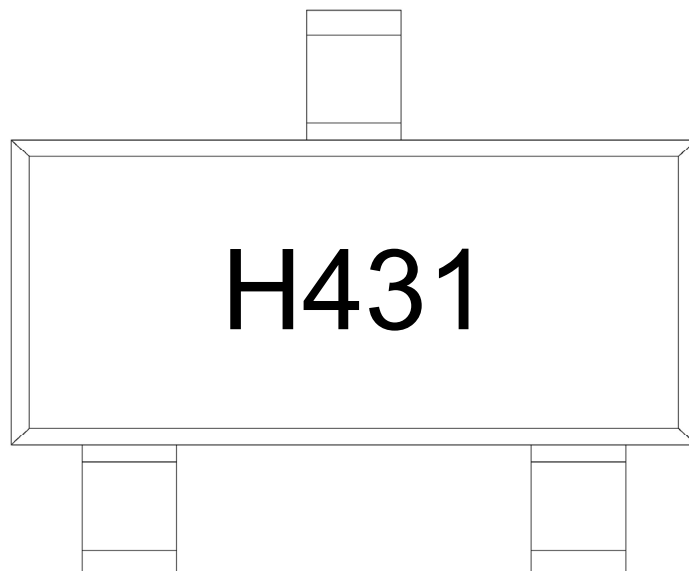

说明：

H： 为公司代码

431： 为型号代码

Note:

H: Company Code.

431: Product Type.

回流焊温度曲线图(无铅) / Temperature Profile for IR Reflow Soldering(Pb-Free)



说明：

- 1、预热温度 25~150°C，时间 60~90sec;
- 2、峰值温度 245±5°C，时间持续为 5±0.5sec;
- 3、焊接制程冷却速度为 2~10°C/sec.

Note:

- 1.Preheating:25~150°C, Time:60~90sec.
- 2.Peak Temp.:245±5°C, Duration:5±0.5sec.
3. Cooling Speed: 2~10°C/sec.

耐焊接热试验条件 / Resistance to Soldering Heat Test Conditions

温度：260±5°C

时间：10±1 sec.

Temp.:260±5°C

Time:10±1 sec

包装规格 / Packaging SPEC.

卷盘包装 / REEL

Package Type 封装形式	Units 包装数量					Dimension 包装尺寸 (unit: mm ³)		
	Units/Reel 只/卷盘	Reels/Inner Box 卷盘/盒	Units/Inner Box 只/盒	Inner Boxes/Outer Box 盒/箱	Units/Outer Box 只/箱	Reel	Inner Box 盒	Outer Box 箱
SOT-23	3,000	10	30,000	6	180,000	7" ×8	180×120×180	390×385×205

使用说明 / Notices