

Adjustable Precision Shunt Regulators

TL431MKN3

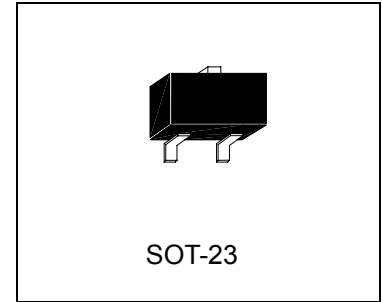

Description

The TL431MKN3 series are three-terminal adjustable regulators with guaranteed thermal stability over applicable temperature range. The output voltage may be set to any value between V_{REF} (approximately 2.495 volts) and 36 volts with two external resistors. These devices have a typical dynamic output impedance of 0.1Ω . Active output circuitry provides a very sharp turn-on characteristic, making these devices excellent replacement for zener diodes in many applications.

Features

- Programmable output voltage
- Temperature coefficient is 50ppm/°C typical
- Improved temperature compensation
- Sink current capability of 0.1mA to 100mA
- Low output noise voltage
- Fast turn on response
- Heat Resistance, Soldering iron : 300°C, 5 seconds
- Low dynamic output impedance 0.1Ω (typ.)
- Electrostatic discharge voltage 2.5kV.
- Pb-free lead plating and halogen-free package

Classification

Rank	A	B	C
V_{REF}	$2.495\pm 0.5\%$	$2.495\pm 1\%$	$2.495\pm 2\%$

Ordering Information

Device	Package	Shipping
TL431MKN3- X - T1 - G	SOT-23 (Pb-free lead plating and halogen-free package)	3000 pcs / tape & reel

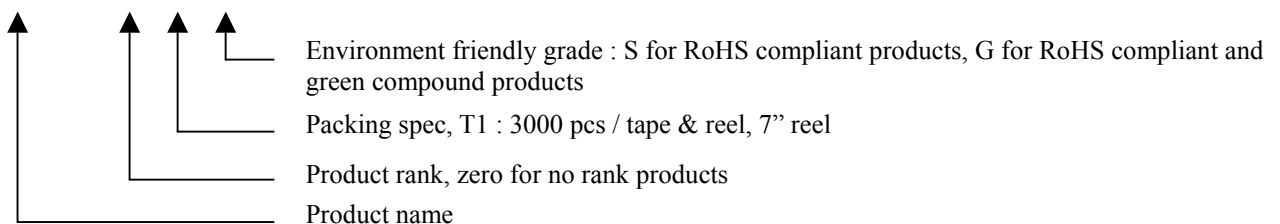

Absolute Maximum Ratings (Over operating free-air temperature range, unless otherwise specified)

Characteristics	Symbol	Value	Unit
Cathode Voltage	V _{KA}	40	V
Cathode Current Range (Continuous)	I _K	-100~+150	mA
Reference Input Current Range	I _{REF}	-0.05~+10	mA
Power Dissipation	P _D	300	mW
Operating Free-air Temperature Range	T _j	-40~+125	°C
Lead Temperature (1.6mm aside from the case, 10s)	T _L	260	°C
ESD(HBM)	V _{ESD}	2500	V
Storage Temperature Range	T _{stg}	-65~+150	°C

Thermal Data

Parameter	Symbol	Value	Unit
Thermal Resistance, Junction-to-case, max	R _{th,j-c}	50	°C/W
Thermal Resistance, Junction-to-ambient, max (Note)	R _{th,j-a}	416	

Note: When mounted on FR-4 PCB with area measuring 10×10 mm

Functional Block Diagram & Symbol

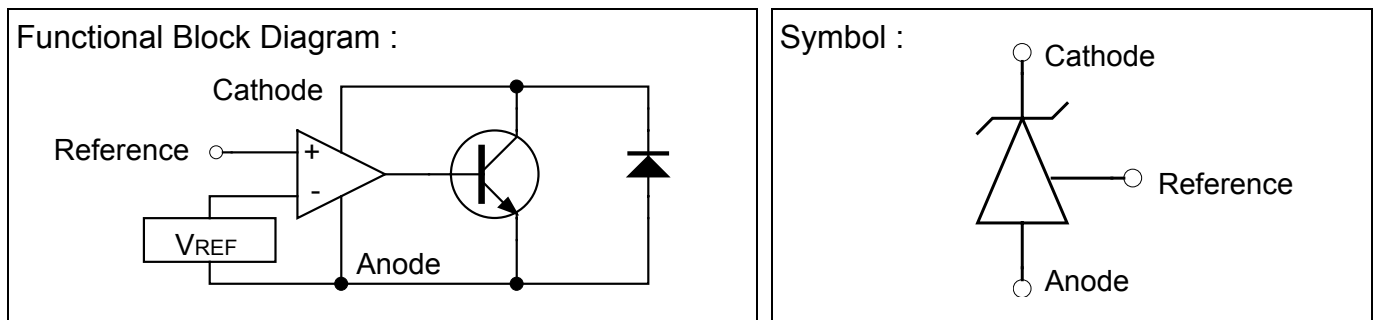

Test Circuits

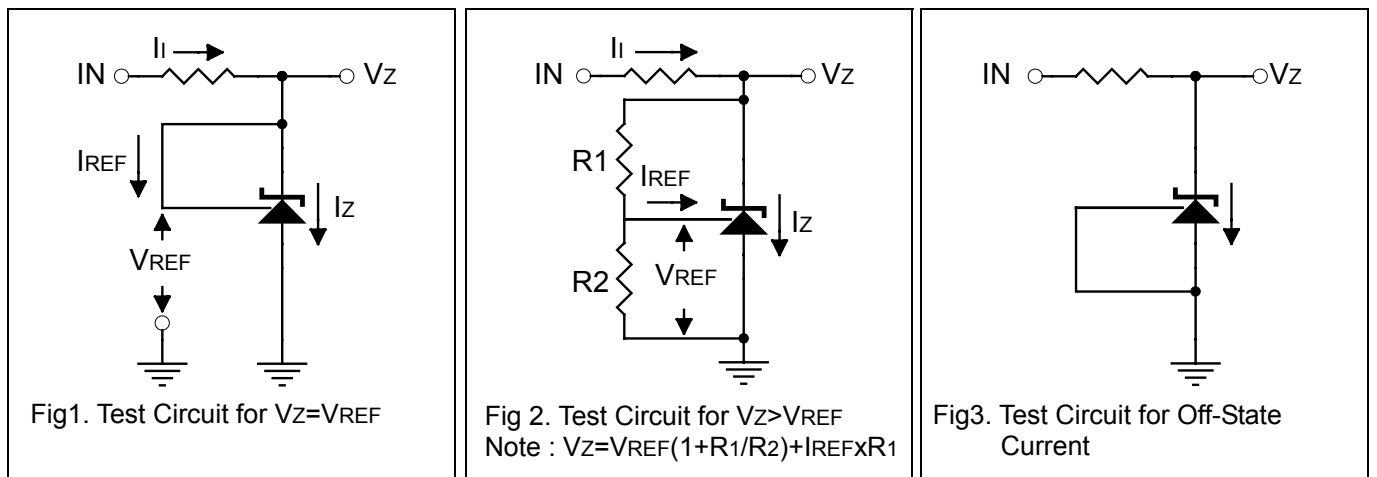

Electrical Characteristics (Ta=25°C unless otherwise specified)

Characteristics	Symbol	Test Conditions	Min	Typ	Max	Unit	Test Circuit
Reference Input Voltage A-rank B-rank C-rank	V_{REF}	$V_{KA}=V_{REF}, I_K=10mA$	2.480	2.495	2.510	V	1
			2.470	2.495	2.520		
			2.445	2.495	2.545		
Deviation of Reference Input Voltage Over Full Temperature Range	$V_{REF(dev)}$	$V_{KA}=V_{REF}, I_K=10mA$ $0 \leq T_a \leq 125^\circ C$	-	8	17	mV	1
Ratio of Change in Reference Input Voltage to the Change in Cathode Voltage	$\Delta V_{REF} / \Delta V_{KA}$	$I_K=10mA,$ $\Delta V_{KA}=10V$ to V_{REF}	-	-1.0	-2.7	mV/V	2
		$I_K=10mA,$ $\Delta K_{KA}=36V$ to $10V$	-	-0.4	-2.0	mV/V	2
Reference Input Current	I_{REF}	$I_K=10mA, R_1=10k\Omega,$ $R_2=\infty$	-	0.5	1.2	μA	2
Deviation of Reference Input Current Over Full Temperature Range	$I_{REF(dev)}$	$I_K=10mA, R_1=10k\Omega,$ $R_2=\infty, T_a=Full\ Range$	-	0.4	1.2	μA	2
Minimum Cathode Current for Regulation	$I_{K(min)}$	$V_{KA}=V_{REF}$	-	0.04	0.3	mA	1
Off-State Cathode Current	$I_{K(off)}$	$V_{KA}=36V, V_{REF}=0V$	-	0.01	0.8	μA	3
Dynamic impedance	Z_{KA}	$V_{KA}=V_{REF}, f \leq 1.0KHz$ $I_K=0.2$ to $100mA$	-	0.1	0.37	Ω	1

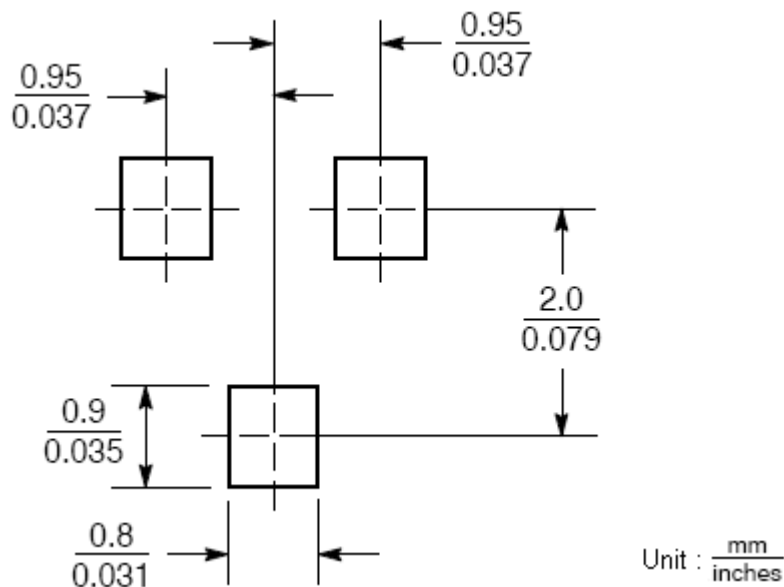
Recommended Soldering Footprint

Typical Characteristics

CATHODE CURRENT vs CATHODE VOLTAGE

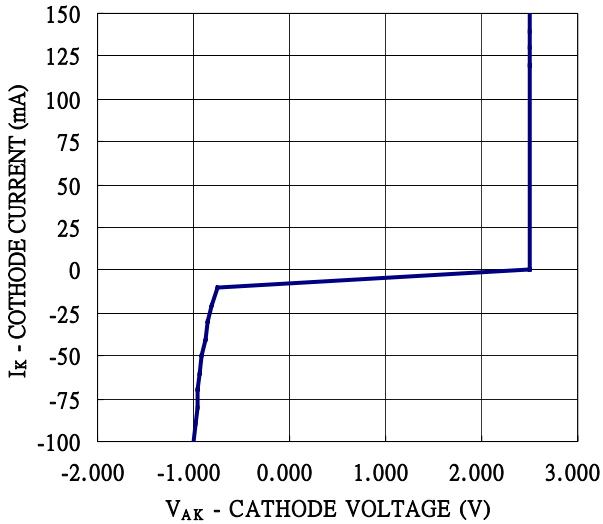

CATHODE CURRENT vs CATHODE VOLTAGE

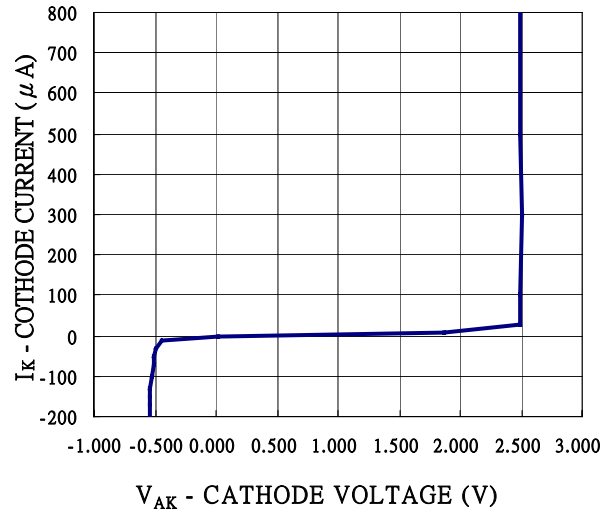

REFERENCE INPUT VOLTAGE vs AMBIENT TEMPERATURE

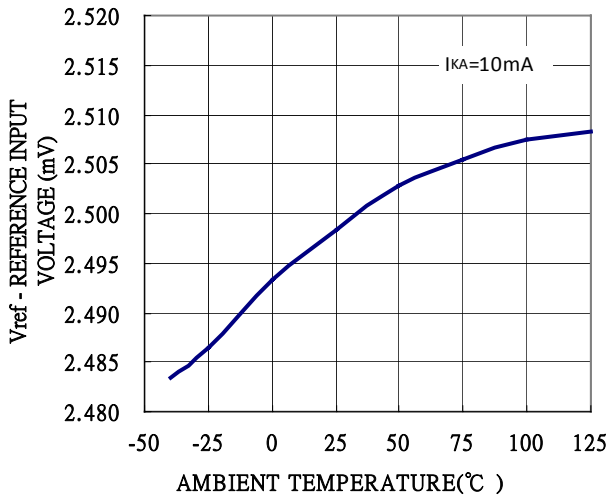

REFERENCE INPUT CURRENT vs AMBIENT TEMPERATURE

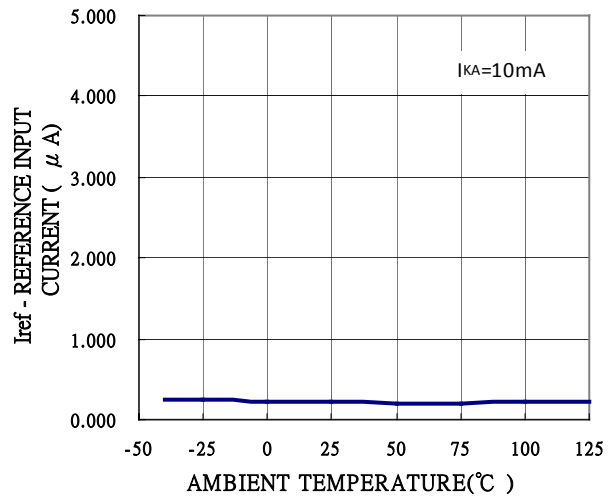

Typical Characteristics(Cont.)

CATHODE VOLTAGE vs REFERENCE INPUT VOLTAGE

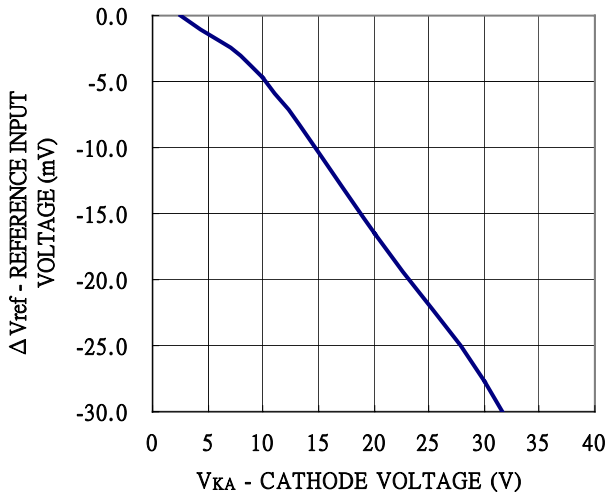

DYNAMIC IMPEDANCE vs FREQUENCY

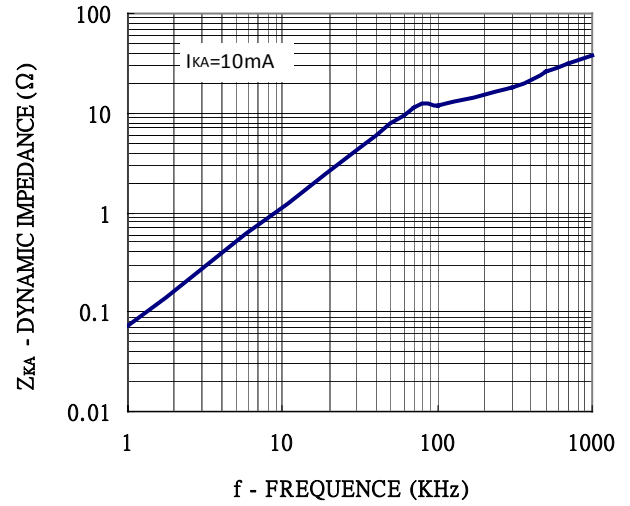

OPEN-LOOP VOLTAGE GAIN vs FREQUENCY

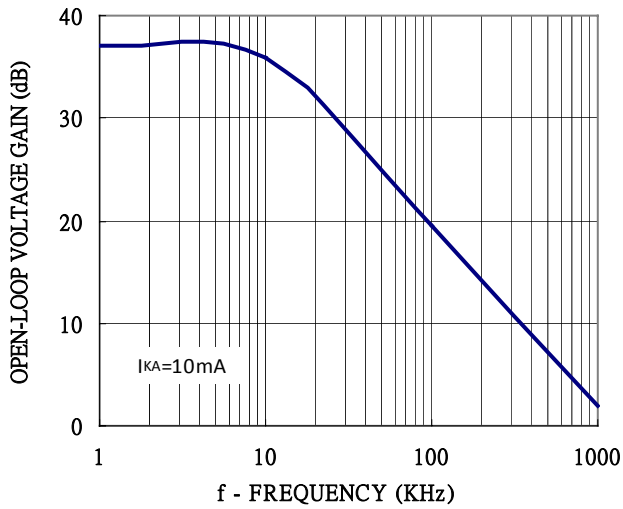

Power Derating Curve

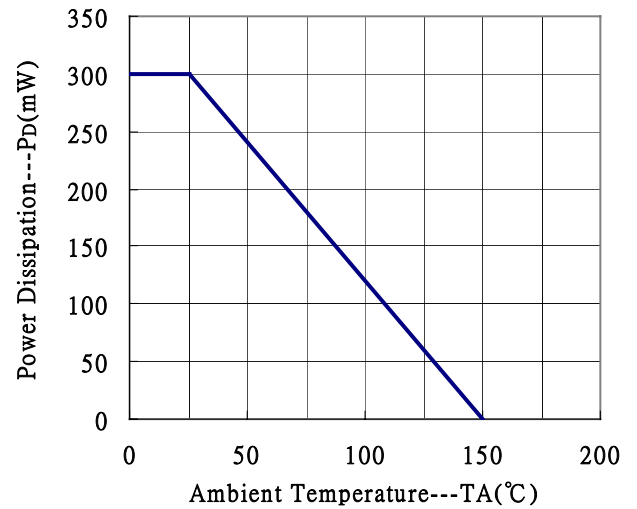

Typical Characteristics(Cont.)

Stability Boundary Conditions

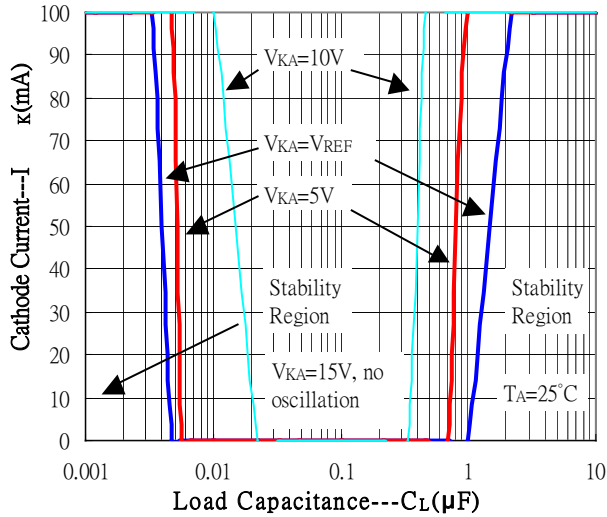

MINIMUM CATHODE CURRENT for REGULATION vs AMBIENT TEMPERATURE

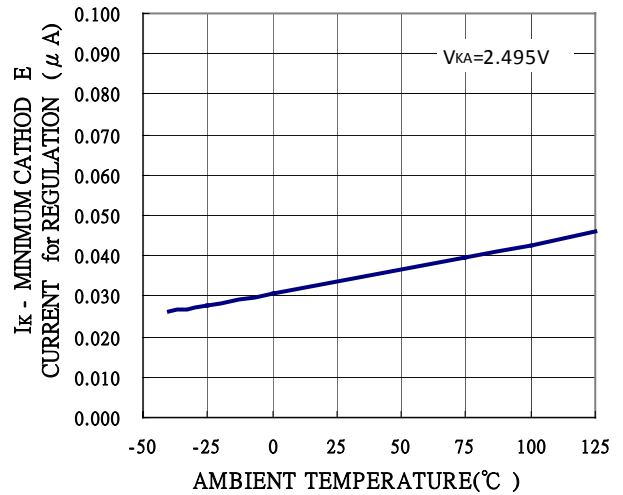

Test Circuit for Stability Boundary Conditions

$V_{KA}=V_{REF}$

$V_{KA}=5V, 10V, 15V$

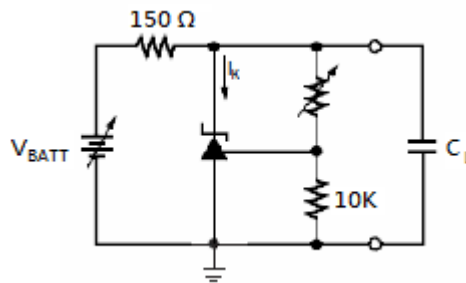
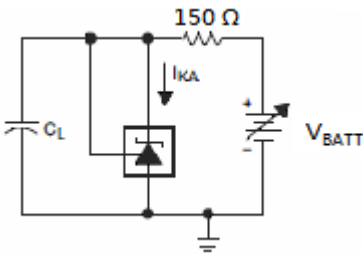

※ C_L : MLCC capacitor

Reel Dimension

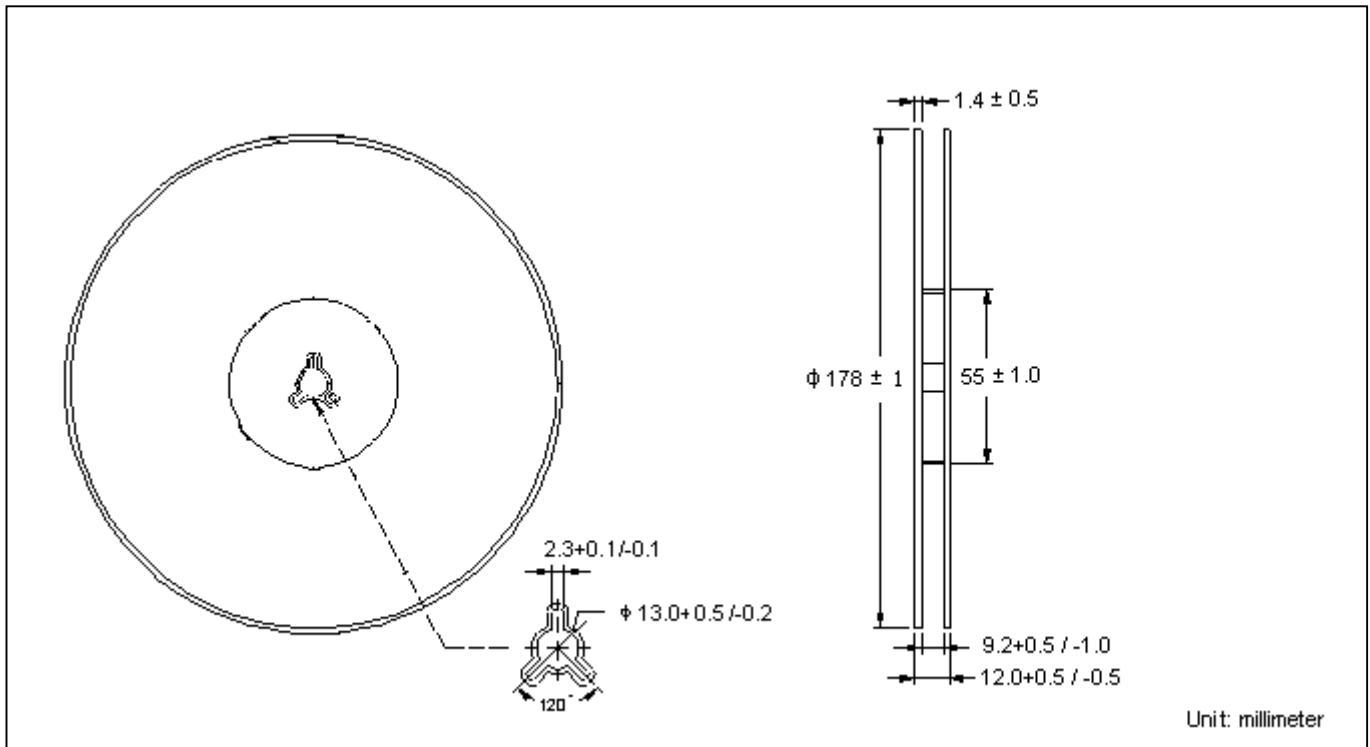

Carrier Tape Dimension

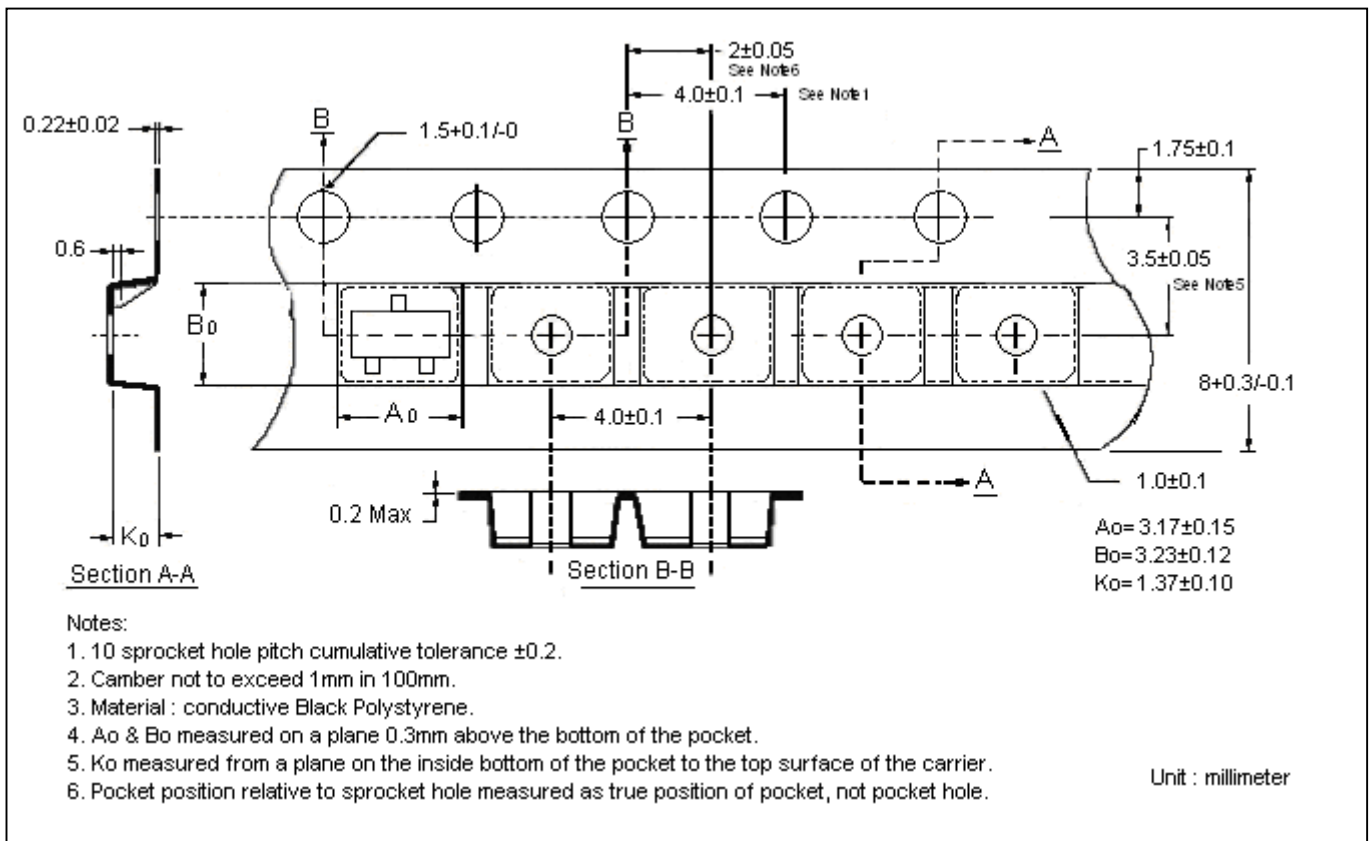

Recommended wave soldering condition

Product	Peak Temperature	Soldering Time
Pb-free devices	260 +0/-5 °C	5 +1/-1 seconds

Recommended temperature profile for IR reflow

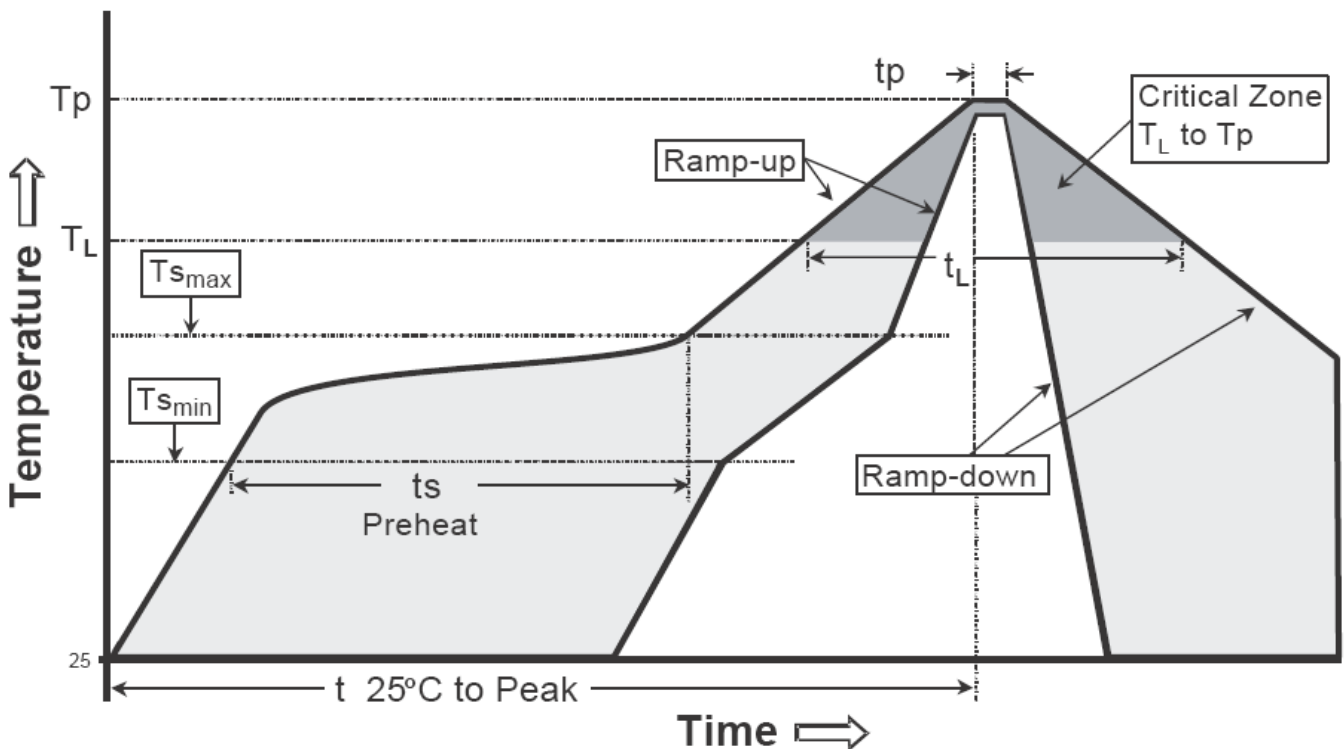

Profile feature	Sn-Pb eutectic Assembly	Pb-free Assembly
Average ramp-up rate (T _{smax} to T _p)	3°C/second max.	3°C/second max.
Preheat		
-Temperature Min(T _{s min})	100°C	150°C
-Temperature Max(T _{s max})	150°C	200°C
-Time(t _{s min} to t _{s max})	60-120 seconds	60-180 seconds
Time maintained above:		
-Temperature (T _L)	183°C	217°C
- Time (t _L)	60-150 seconds	60-150 seconds
Peak Temperature(T _P)	240 +0/-5 °C	260 +0/-5 °C
Time within 5°C of actual peak temperature(tp)	10-30 seconds	20-40 seconds
Ramp down rate	6°C/second max.	6°C/second max.
Time 25 °C to peak temperature	6 minutes max.	8 minutes max.

Note : All temperatures refer to topside of the package, measured on the package body surface.

SOT-23 Dimension

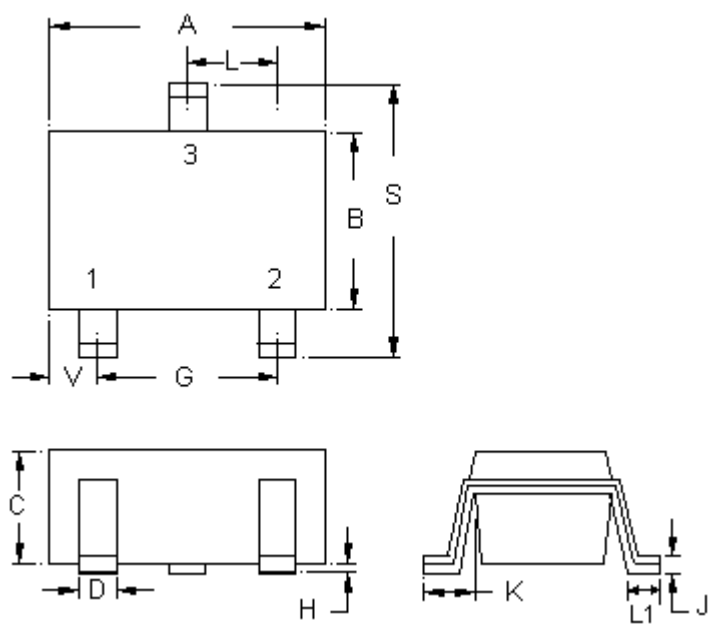

Marking:

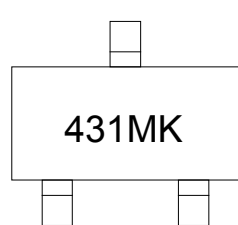

3-Lead SOT-23 Plastic
 Surface Mounted Package
 CYStek Package Code: N3

Style: Pin 1.Cathode 2.Reference 3.Anode

DIM	Inches		Millimeters		DIM	Inches		Millimeters	
	Min.	Max.	Min.	Max.		Min.	Max.	Min.	Max.
A	0.1102	0.1204	2.80	3.04	J	0.0032	0.0079	0.08	0.20
B	0.0472	0.0669	1.20	1.70	K	0.0118	0.0266	0.30	0.67
C	0.0335	0.0512	0.89	1.30	L	0.0335	0.0453	0.85	1.15
D	0.0118	0.0197	0.30	0.50	S	0.0830	0.1161	2.10	2.95
G	0.0669	0.0910	1.70	2.30	V	0.0098	0.0256	0.25	0.65
H	0.0000	0.0040	0.00	0.10	L1	0.0118	0.0197	0.30	0.50

Notes: 1.Controlling dimension: millimeters.
 2.Maximum lead thickness includes lead finish thickness, and minimum lead thickness is the minimum thickness of base material.
 3.If there is any question with packing specification or packing method, please contact your local CYCtek sales office.

Material:

- Lead: Pure tin plated.
- Mold Compound: Epoxy resin family, flammability solid burning class: UL94V-0.

Important Notice:

- All rights are reserved. Reproduction in whole or in part is prohibited without the prior written approval of CYStek.
- CYStek reserves the right to make changes to its products without notice.
- CYStek **semiconductor products are not warranted to be suitable for use in Life-Support Applications, or systems.**
- CYStek assumes no liability for any consequence of customer product design, infringement of patents, or application assistance.