

Features

- Internal regulator provides a stable 5V reference supply trimmed to 5%
- Uncommitted output TR for 200mA sink or source current
- Output control for push-pull or single-ended operation
- Variable duty cycle by dead time control (pin 4) Complete PWM control circuit
- On-chip oscillator with master or slave operation
- Internal circuit prohibits double pulse at either output

Description

The TL494 is used for the control circuit of the PWM switching regulator. The TL494 consists of 5V reference voltage circuit, two error amplifiers, flip flop, an output control circuit, a PWM comparator, a dead time comparator and an oscillator. This device can be operated in the switching frequency of 1 KHz to 300 KHz.

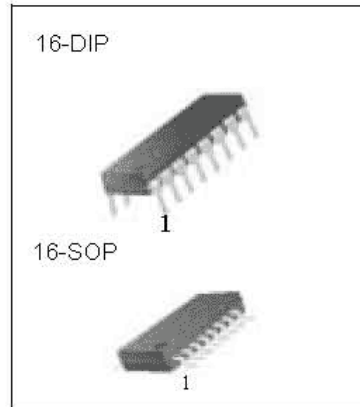

Internal Block Diagram

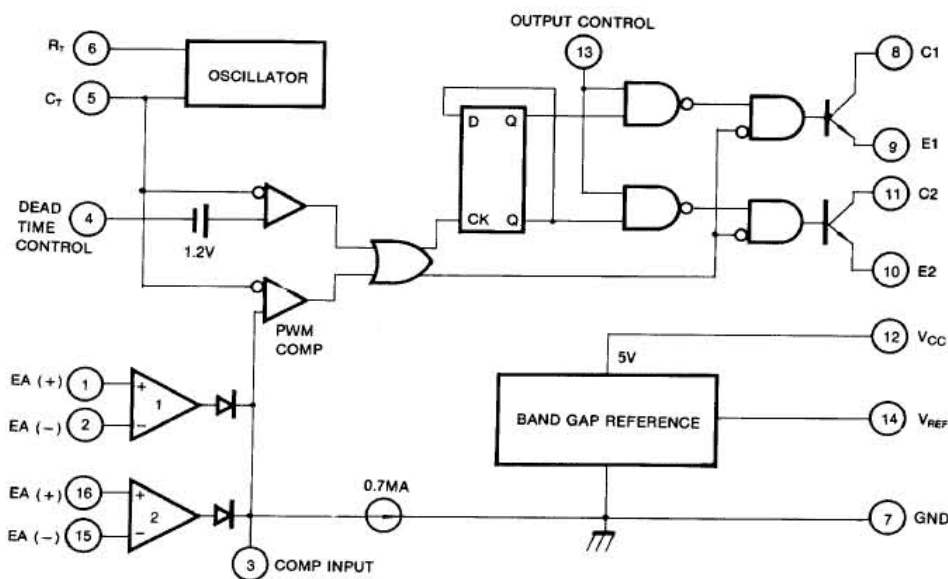

Absolute Maximum Ratings

Parameter	Symbol	Value	Unit
Supply Voltage	V _{CC}	42	V
Collector Supply Voltage	V _C	42	V
Output Current	I _O	250	mA
Amplifier Input Voltage	V _{IN}	V _{CC} + 0.3	V
Power Dissipation (T _A = 25°C)	P _D	1 (TL494CN) 0.9 (TL494CD)	W
Operating Temperature Range	T _{OPR}	0 ~ +70	°C
Storage Temperature Range	T _{STG}	-65 ~ + 150	°C

Electrical Characteristics

(V_{CC} = 20V, f = 10KHz, T_A = 0°C to + 70°C, unless otherwise specified)

Parameter	Symbol	Conditions	Min.	Typ.	Max.	Unit
REFERENCE SECTION						
Reference Output Voltage	V _{REF}	I _{REF} = 1mA	4.75	5.0	5.25	V
Line Regulation	ΔV _{REF}	V _{CC} = 7V to 40V	-	2.0	25	mV
Temperature Coefficient of V _{REF}	ΔV _{REF} /ΔT	T _A = 0°C to 70°C	-	0.01	0.03	%/°C
Load Regulation	ΔV _{REF}	I _{REF} = 1mA to 10mA	-	1.0	15	mV
Short-Circuit Output Current	I _{SC}	V _{REF} = 0V	10	35	50	mA
OSCILLATOR SECTION						
Oscillation Frequency	f	C _T = 0.01μF, R _T = 12KΩ	-	10	-	KHz
Frequency Change with Temperature	Δf/ΔT	C _T = 0.01μF, R _T = 12KΩ	-	-	2	%
DEAD TIME CONTROL SECTION						
Input Bias Current	I _{BIAS}	V _{CC} = 15V, 0V ≤ V ₄ ≤ 5.25V	-	-2.0	-10	μA
Maximum Duty Cycle	D(MAX)	V _{CC} = 15V, V ₄ = 0V O.C Pin = V _{REF}	45	-	-	%
Input Threshold Voltage	V _I TH	Zero Duty Cycle	-	3.0	3.3	V
		Max. Duty Cycle	0	-	-	
ERROR AMP SECTION						
Input Offset Voltage	V _{IO}	V ₃ = 2.5V	-	2.0	10	mV
Input Offset Current	I _{IO}	V ₃ = 2.5V	-	25	250	mA
Input Bias Current	I _{BIAS}	V ₃ = 2.5V	-	0.2	1.0	μA
Common Mode Input Voltage	V _{CM}	7V ≤ V _{CC} ≤ 40V	-0.3	-	V _{CC}	V
Open-Loop Voltage Gain	G _{VO}	0.5V ≤ V ₃ ≤ 3.5V	70	95	-	dB
Unit-Gain Bandwidth	BW	-	-	650	-	KHz
PWM COMPARATOR SECTION						
Input Threshold Voltage	V _I TH	Zero Duty Cycle	-	4	4.5	V
Input Sink Current	I _{SINK}	V ₃ = 0.7V	-0.3	-0.7	-	mV
OUTPUT SECTION						
Output Saturation Voltage Common Emitter	V _{CE} (SAT)	V _E = 0, I _C = 200mA	-	1.1	1.3	V
Common Collector	V _{CC} (SAT)	V _C = 15V, I _E = -200mA	-	1.5	2.5	
Collector Off-State Current	I _C (OFF)	V _{CC} = 40V, V _{CE} = 40V	-	2	100	μA
Emitter Off-State Current	I _E (OFF)	V _{CC} = V _C = 40V, V _E = 0	-	-	-100	
TOTAL DEVICE						
Supply Current	I _{CC}	Pin 6 = V _{REF} , V _{CC} = 15V	-	6	10	mA
OUTPUT SWITCHING CHARACTERISTIC						
Rise Time	t _R	-	-	-	-	-
Common Emitter	-	-	-	100	200	ns
Common Collector	-	-	-	100	200	
Fall Time	t _F	-	-	-	-	-
Common Emitter	-	-	-	25	100	ns
Common Collector	-	-	-	40	100	

Typical Application

Pulse Width Modulated Step-down Converter

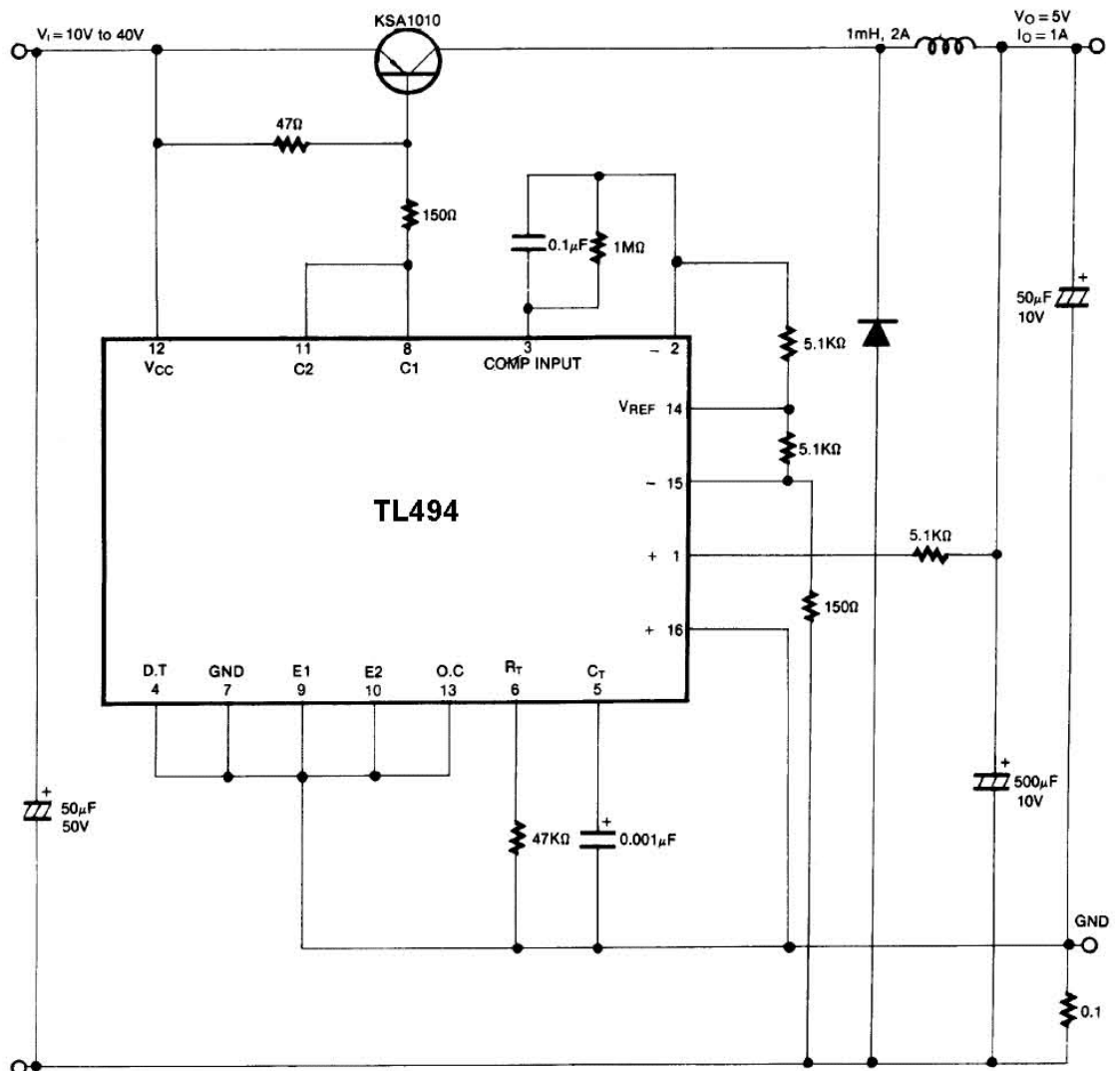

Mechanical Dimensions

Package

16-DIP

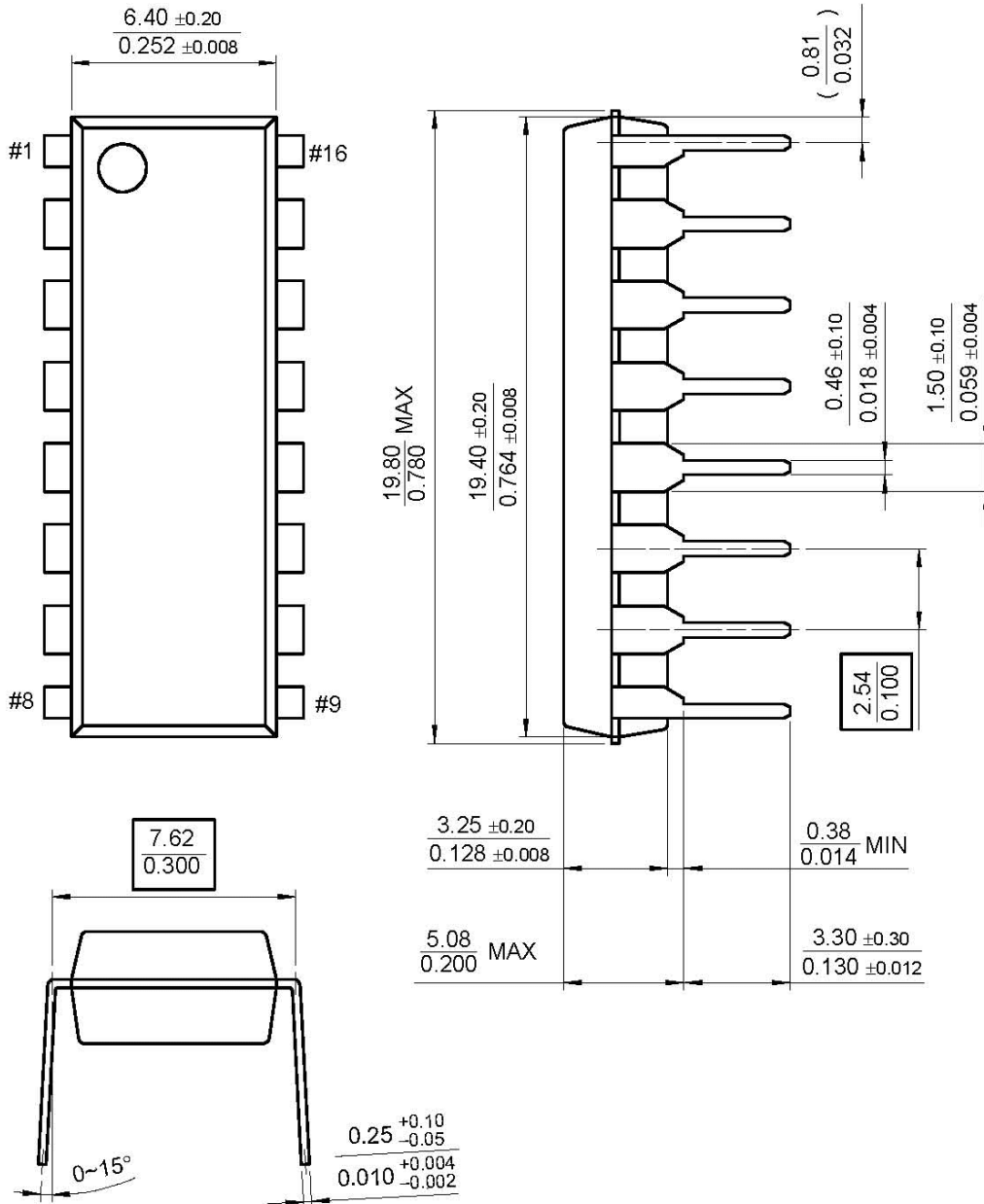

Mechanical Dimensions (Continued)

Package

16-SOP

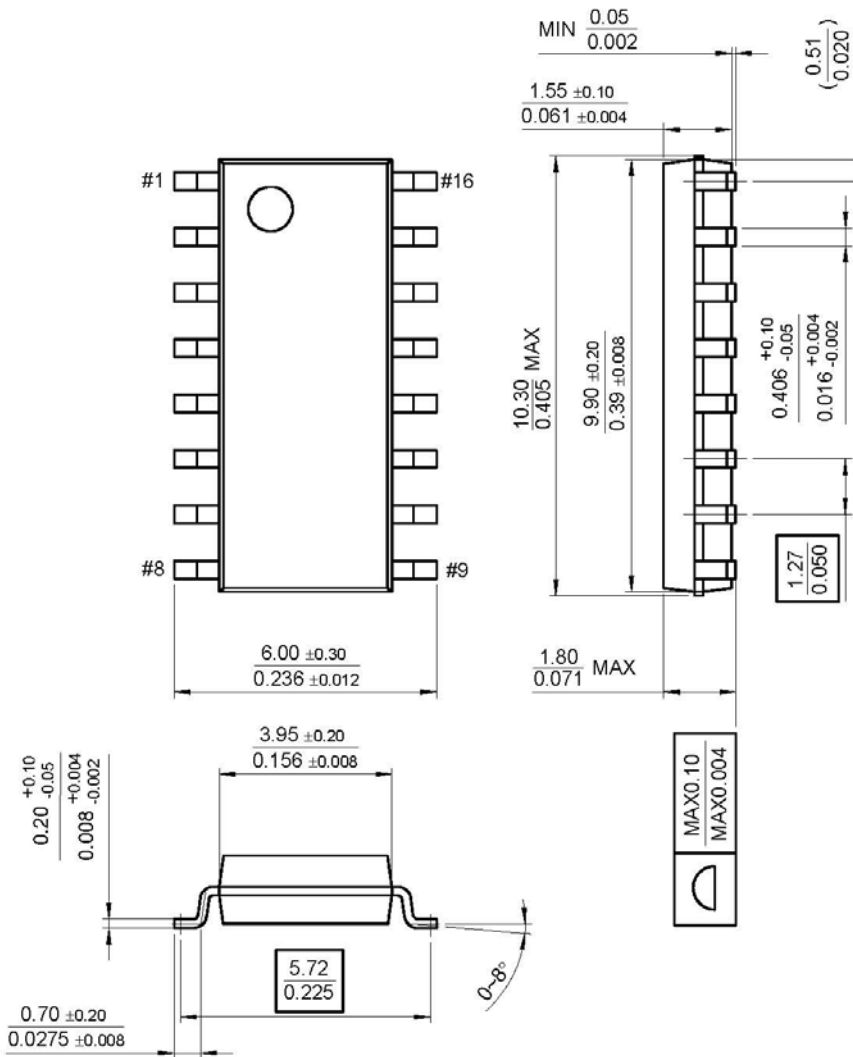

Ordering Information

Product Number	Package	Operating Temperature
TL494CN	16 DIP	0 ~ + 70°C
TL494CD	16 SOP	