

SDIO PRODUCT SPECIFICATION

IEEE 802.11 b/g/n 2.4GHz 1T1R WiFi Module

TL8189FBA

Single Module

深圳市创凌智联科技有限公司

工厂地址：深圳市宝安区固戍三围华丰第一科技园 A 区石街 B 栋厂房二楼

联系方式：0755-88828355/83224500

公司网站：www.trolink.cn

联系邮箱：frankai@trolink.cn

1. General Description

The Realtek RTL8189FTV is a highly integrated single-chip 802.11n Wireless LAN (WLAN) network SDIO interface (SDIO 1.1/ 2.0 compliant) controller. It is a WLAN MAC, a 1T1R capable WLAN baseband, and WLAN RF in a single chip. The RTL8189FTV provides a complete solution for a high throughput performance integrated wireless LAN device.

The RTL8189FTV WLAN baseband implements Orthogonal Frequency Division Multiplexing (OFDM) with 1 transmit and 1 receive path and is compatible with the IEEE 802.11n specification. Features include one spatial stream transmission, short guard interval (GI) of 400ns, spatial spreading, and transmission over 20MHz and 40MHz bandwidth.

For legacy compatibility, Direct Sequence Spread Spectrum (DSSS), Complementary Code Keying (CCK) and OFDM baseband processing are included to support all IEEE 802.11b and 802.11g data rates. Differential phase shift keying modulation schemes, DBPSK and DQPSK with data scrambling capability, are available, and CCK provides support for legacy data rates, with long or short preamble. The high-speed FFT/IFFT paths, combined with BPSK, QPSK, 16QAM, and 64QAM modulation of the individual subcarriers and rate compatible punctured convolutional coding with coding rate of 1/2, 2/3, 3/4, and 5/6, provide higher data rates of 54Mbps and 150Mbps for IEEE 802.11g and 802.11n OFDM respectively.

The RTL8189FTV WLAN Controller builds in an enhanced signal detector, an adaptive frequency domain equalizer, and a soft-decision Viterbi decoder to alleviate severe multi-path effects and mutual interference in the reception of multiple streams. Robust interference detection and suppression are provided to protect against Bluetooth, cordless phone, and microwave oven interference.

Efficient IQ-imbalance, DC offset, phase noise, frequency offset, and timing offset compensations are provided for the radio frequency front-end. Selectable digital transmit and receive FIR filters are provided to meet transmit spectrum mask requirements and to reject adjacent channel interference, respectively.

The RTL8189FTV WLAN Controller supports fast receiver Automatic Gain Control (AGC) with synchronous and asynchronous control loops among antennas, antenna diversity functions, and adaptive transmit power control function to obtain the better performance in the analog portions of the transceiver.

The RTL8189FTV WLAN MAC supports 802.11e for multimedia applications, 802.11i for security, and 802.11n for enhanced MAC protocol efficiency. Using packet aggregation techniques such as A-MPDU with BA and A-MSDU, protocol efficiency is significantly improved. Power saving mechanisms such as Legacy Power Save, and U-APSD, reduce the power wasted during idle time, and compensates for the extra power required to transmit OFDM. The RTL8189FTV provides simple legacy and 20MHz/40MHz co-existence mechanisms to ensure backward and network compatibility.

2.Features

<p>General</p> <ul style="list-style-type: none"> ■ CMOS MAC, Baseband PHY, and RF in a single chip for IEEE 802.11b/g/n compatible WLAN ■ Complete 802.11n solution for 2.4GHz band ■ 72.2Mbps receive PHY rate and 72.2Mbps transmit PHY rate using 20MHz bandwidth ■ 150Mbps receive PHY rate and 150Mbps transmit PHY rate using 40MHz bandwidth ■ Compatible with 802.11n specification ■ Backward compatible with 802.11b/g devices while operating in 802.11n mode <p>Host Interface</p> <ul style="list-style-type: none"> ■ Complies with SDIO 1.1/ 2.0 for WLAN with clock rate up to 100MHz ■ GSPI interface for configurable endian for WLAN <p>Standards Supported</p> <ul style="list-style-type: none"> ■ IEEE 802.11b/g/n compatible WLAN ■ IEEE 802.11e QoS Enhancement (WMM) ■ 802.11i (WPA, WPA2). Open, shared key, and pair-wise key authentication services ■ Switch diversity for DSSS/CCK ■ Hardware antenna diversity in per packet base ■ Selectable receiver FIR filters ■ Programmable scaling in transmitter and receiver to trade quantization noise against increased probability of clipping 	<p>WLAN MAC Features</p> <ul style="list-style-type: none"> ■ Frame aggregation for increased MAC efficiency (A-MSDU, A-MPDU) ■ Low latency immediate High-Throughput Block Acknowledgement (HT-BA) ■ PHY-level spoofing to enhance legacy compatibility ■ Power saving mechanism ■ Channel management and co-existence ■ Transmit Opportunity (TXOP) Short Inter-Frame Space (SIFS) bursting for higher multimedia bandwidth <p>WLAN PHY Features</p> <ul style="list-style-type: none"> ■ IEEE 802.11n OFDM ■ One Transmit and one Receive path (1T1R) ■ 20MHz and 40MHz bandwidth transmission ■ Short Guard Interval (400ns) ■ DSSS with DBPSK and DQPSK, CCK modulation with long and short preamble ■ OFDM with BPSK, QPSK, 16QAM, and 64QAM modulation. Convolutional Coding Rate: 1/2, 2/3, 3/4, and 5/6 ■ Maximum data rate 54Mbps in 802.11g and 150Mbps in 802.11n ■ Fast receiver Automatic Gain Control (AGC) ■ On-chip ADC and DAC <p>Peripheral Interfaces</p> <ul style="list-style-type: none"> ■ General Purpose Input/Output (4 pins)
--	---

3.PRODUCT SPECIFICATIONS

Realtek RTL8189FTV. Functional Specifications

Standards	IEEE 802.11b, IEEE 802.11g, Draft IEEE 802.11n, IEEE 802.11d, IEEE 802.11e, IEEE 802.11h, IEEE 802.11i
Bus Interface	WiFi: GSPI/SDIO
Media Access Control	CSMA/CA with ACK
Network Architecture	Ad-hoc mode (Peer-to-Peer) Infrastructure mode Scatter Net
Operating Channel	11: (Ch. 1-11) – United States 13: (Ch. 1-13) – Europe 14: (Ch. 1-14) – Japan
Frequency Range	2.400GHz ~ 2.484 GHz
Security	WPA, WPA-PSK, WPA2, WPA2-PSK, WEP64bit&128bit, IEEE802.11x, IEEE 802.11i
Operating Voltage	3.3 V \pm 9% I/O supply voltage
OS supported	Windows XP/Win7/Linux/Android

4.DC Characteristics

1) Power Supply Characteristics

Symbol	Parameter	Minimum	Typical	Maximum	Units
VDD33(pin#9)	3.3V Power Supply Voltage	3.0	3.3	3.6	V
IDD33	3.3V Rating Current	-	-	600	mA

2) Digital IO Pin DC Characteristics

Symbol	Parameter	Minimum	Typical	Maximum	Units	
VDDIO(pin#22)	3.3V I/O Power Voltage	V _{IH}	2.0	3.3	3.6	V
		V _{IL}	--	0	0.9	V
		V _{OH}	2.97	--	3.3	V
		V _{OL}	0	--	0.33	V
	1.8V I/O Power Voltage	V _{IH}	1.7	1.8	2.0	V
		V _{IL}	--	0	0.8	V
		V _{OH}	1.62	--	1.8	V
		V _{OL}	0	--	0.18	V
CS(PIN#12)	Chip select	V _{IH}	2.0	3.3	3.6	V
		V _{IL}	--	0	0.9	V
WL_HOST_WAKE (PIN#13)	WLAN wake-up HOST	V _{OH}	2.97	--	3.3	V
		V _{OL}	0	--	0.33	V

5.RF Electrical Specifications

1) RF Characteristics for IEEE802.11b (11Mbps mode unless otherwise specified)

Items	Contents			
Specification	IEEE802.11b			
Mode	CCK, DQPSK, DBPSK			
Data Rate	11, 5.5, 2, 1 Mbps			
Channel frequency	2412 ~ 2484 MHz			
RX (per \leq -85dBm@8%)	-85 dBm			
Freq Err Limit	\pm 13ppm			
TX Characteristics	Min.	Typ.	Max.	Unit
Power Level (17 \pm 2 dBm)		17		dBm
EVM (<-18)		-18		dB

2) RF Characteristics for IEEE802.11g (54Mbps mode unless otherwise specified)

Items	Contents			
Specification	IEEE802.11g			
Mode	64 QAM, 16 QAM, QPSK, BPSK			
Data Rate	54, 48, 36, 24, 18, 12, 9, 6 Mbps			
Channel frequency	2412 ~ 2484 MHz			
RX (per \leq -70dBm@10%)	-70 dBm			
Freq Err Limit	\pm 13ppm			
TX Characteristics	Min.	Typ.	Max.	Unit
Power Level (14 \pm 2 dBm)		14		dBm
EVM (<-28)		-28		dB

3) RF Characteristics for IEEE802.11n

Items	Contents			
Specification	IEEE802.11n (MCS 0 to 7 for HT20MHz)			
Mode	64 QAM, 16 QAM, QPSK, BPSK			
Data Rate	65 Mbps			
Channel frequency	2412 ~ 2484 MHz			
RX (per \leq -65dBm@10%)	-65 dBm			
Freq Err Limit	\pm 13ppm			
TX Characteristics	Min.	Typ.	Max.	Unit
Power Level (13 \pm 2 dBm)		13		dBm
EVM (<-28)		-28		dB

4) RF Characteristics for IEEE802.11n

Items	Contents			
Specification	IEEE802.11n (MCS 0 to 7 for HT40MHz)			
Mode	64 QAM, 16 QAM, QPSK, BPSK			
Data Rate	135 Mbps			
Channel frequency	2412 ~ 2484 MHz			
RX (per \leq -65dBm@10%)	-65 dBm			
Freq Err Limit	\pm 13ppm			
TX Characteristics	Min.	Typ.	Max.	Unit
Power Level (13 \pm 2 dBm)		13		dBm
EVM (<-28)		-28		dB

6.Mechanical

Dimensions (mm)	Length	Width	Height
	13.99 (Tolerance: \pm 0.2mm)	12.50 (Tolerance: \pm 0.2mm)	1.6 (Tolerance: \pm 0.2mm)

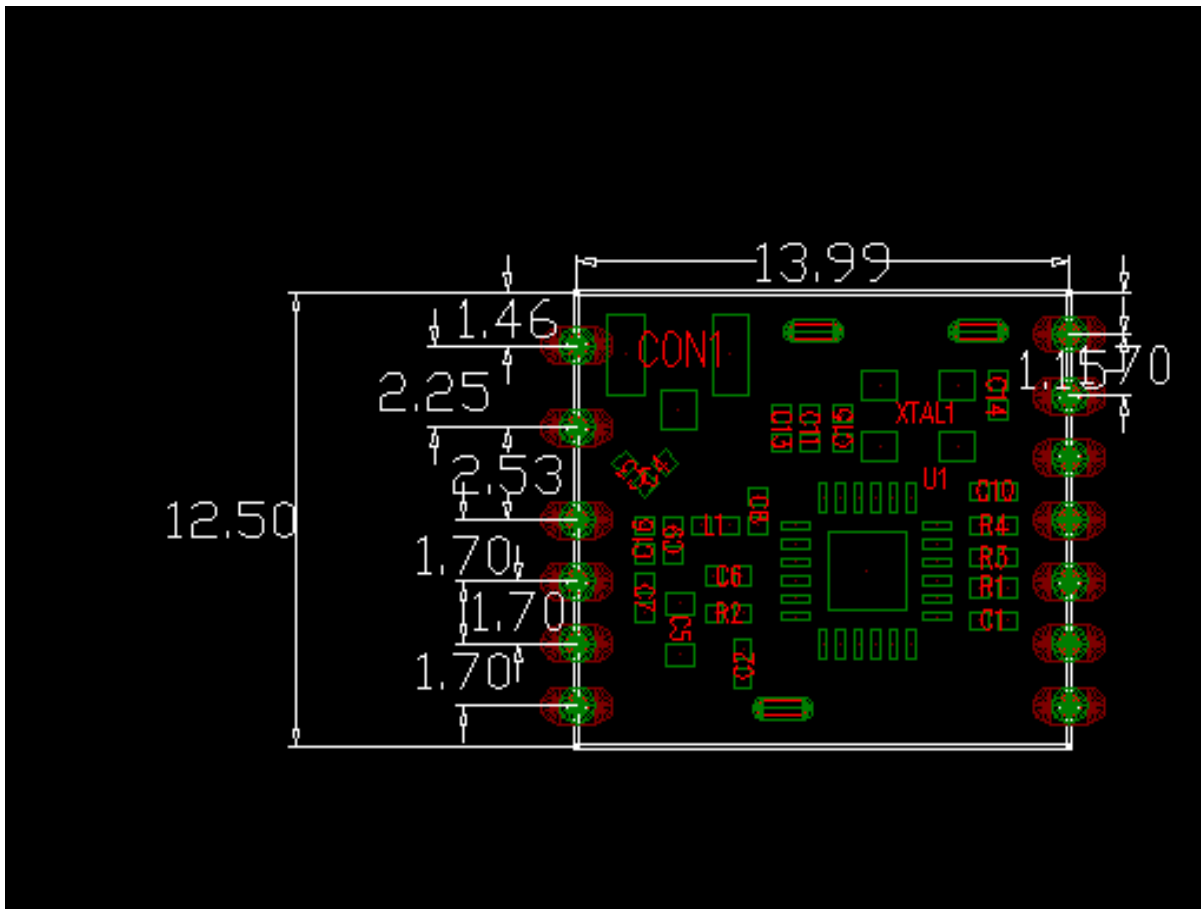

7. Block Diagram

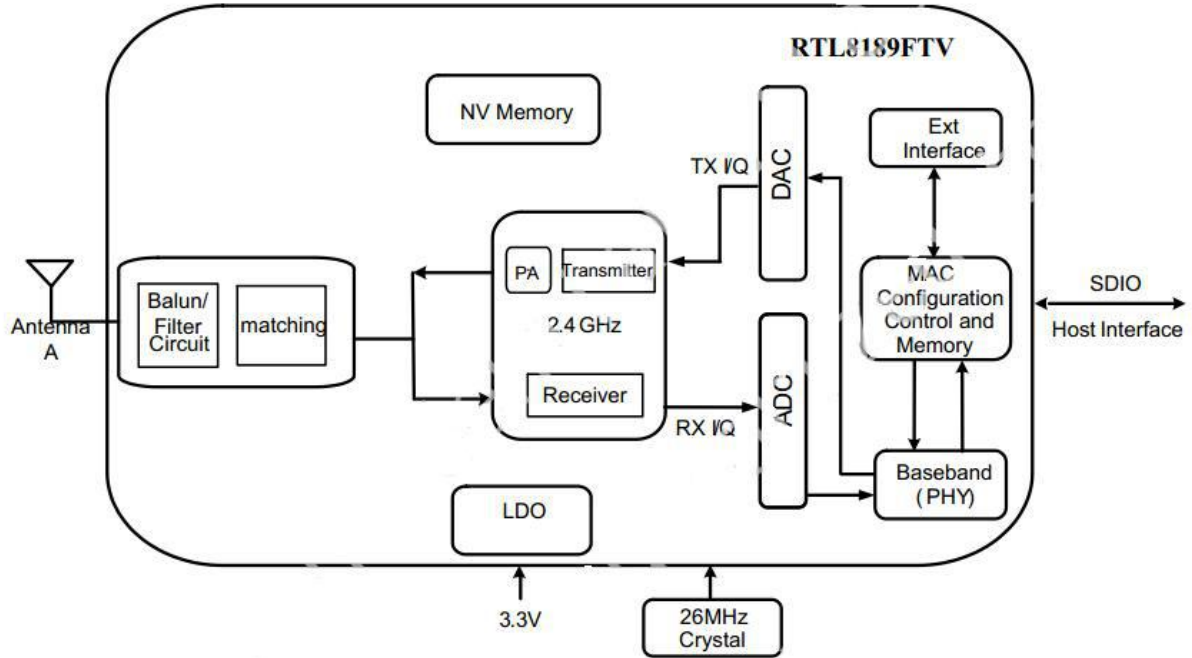

Figure 1. Single-Band 11n (1x1) Solution

Default this module only require 3.3V single power source and core voltage generated by internal voltage regulator.

8. Module PIN feet definition figure



Pin Definition

Pin name	Pin number	I/O	Description	Comment
Power supply				
VCC_3V3	12	I	Power supply	3.3V TYP
VIO	11	I	Power supply for I/O	1.62 -3.3V
GND	7 8 14		Ground	
Power on/down				
CS	13	I	Power down select	
WAKE	10	I	WLAN wake.	
SDIO interface				
SDIO_CLK	6	I/O	SDIO clock / GSPI clock	
SDIO_CMD	1	I/O	SDIO command / GSPI data input	
SDIO_D0	5	I/O	SDIO data 0 / GSPI data output	
SDIO_D1	4	I/O	SDIO data 1 / GSPI Data Out	
SDIO_D2	3	I/O	SDIO data 2	
SDIO_D3	2	I/O	SDIO data 3 / GSPI chip select	
RF interface				
WL_ANT	9	I/O	WLAN radio antenna pad	Impedance must be controlled to 50Ω.

9.1 WIFI\BT RF Circuit reference pictures.

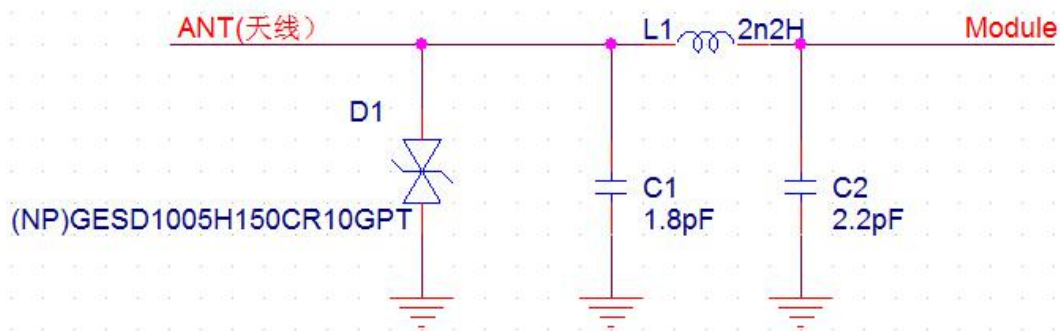

1. Above the dotted box part of the antenna matching is needed, the actual antenna matching electronic parameters shall prevail.

2. For RF part layout to do 50 ohm impedance. can't go on 90° of layout .The line length can't more than 20 mm.

注明：请一定要在焊天线端加一个 TVS 管，防止 ESD 静电打坏 WIFI 模组（如上图参考电路）。

9.2 SDIO interface Circuit reference pictures.

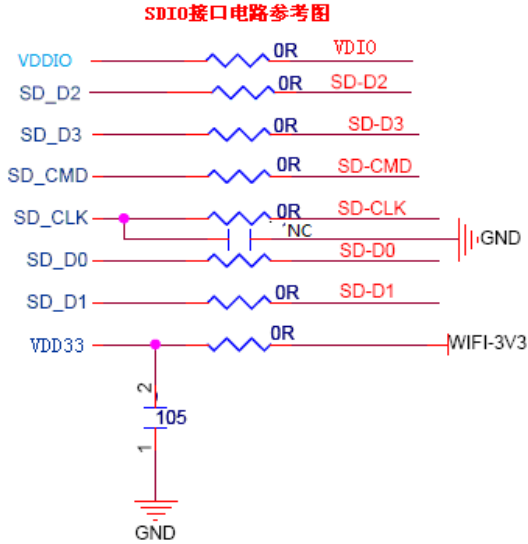

9.3 CS WAKE Reference circuits.

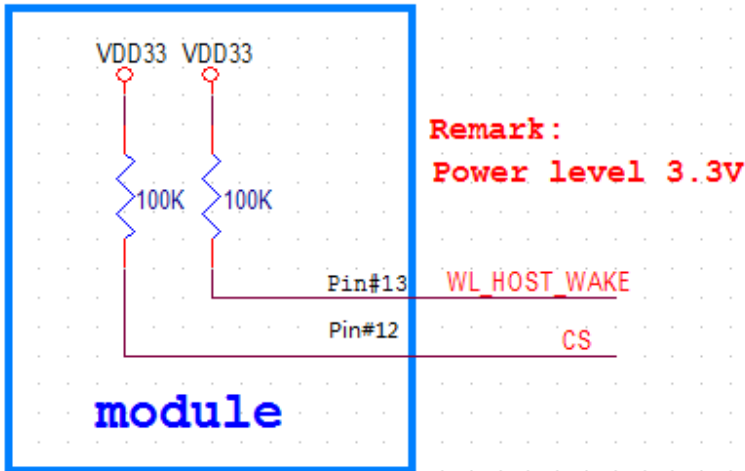

10.Recommended Reflow Profile.

Referred to IPC/JEDEC standard.

Peak Temperature : <250°C

Environmental Requirements and Specifications TP Content

1 Temperature

1.1 Operating Temperature Conditions

The product shall be capable of continuous reliable operation when operating in ambient temperature of -10°C to +70°C.

1.2 Non-Operating Temperature Conditions

Neither subassemblies shall be damaged nor shall the operational performance be degraded when restored to the operating temperature when exposed to storage temperature in the range of -45°C to +135°C.

2 PCB Bending

The PCB bending spec shall be keep planeness under 0.1mm for both NATER and end assembly customer.

3 Handling environment

3.1. ESD

Symbol	Ratings	Max	Unit
V_{ESD} (HBM)	Electrostatic discharge voltage (human body model)	2000	V
V_{ESD} (CDM)	Electrostatic discharge voltage (charge device model)	500	

Please handle it under ESD protection environment.

3.2. Terminals

The product is mounted with motherboard through half hole. In order to prevent poor soldering, please do not touch the pad by hand.

3.3. Falling

It will cause damage on the mounted components when the product is falling or receiving drop shock. It may cause the product mal-function.

4 Storage Condition

4.1 Moisture barrier bag before opened

Moisture barrier bag must be stored under 30 degree C, humidity under 85% RH. The calculated shelf life for the dry packed product shall be a 12 months from the bag seal date.

4.2. Moisture barrier bag open

Humidity indicator cards must be blue, <30%.

5 Baking Condition

Products require baking before mounting if

- a) humidity indicator cards reads >30%
- b) temp <30 degree C, humidity < 70% RH, over 96 hours

Baking condition: 90 degree C, 12-24 hours

Baking times: 1 time

6 Soldering and reflow condition

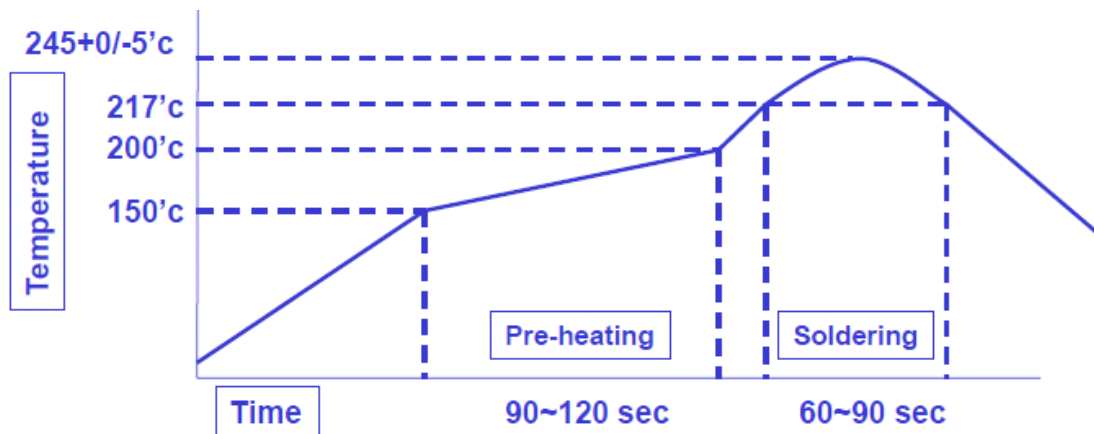

- ◆ Follow the solder paste composition to set the reflow profile
- ◆ Lead free solder paste(SAC305, SAC387 or SAC405) reflow profile setting as above :
 - Ramp up rate (to Peak temp) : < 1.2'c/sec, typically
 - Time above Liquidus(217'C) : 60~90Sec
 - Peak Temp : 245+0/-5'C
 - Ramp-down rate (Peak to RT) : 1~3'C/sec, typically