

### Features

- Double low-side switch, 2 x 0.5 A
- Power limitation
- Overtemperature shutdown
- Overvoltage shutdown
- Status monitoring
- Shorted-load protection
- Integrated clamp diodes
- Temperature range – 40 to 125 °C

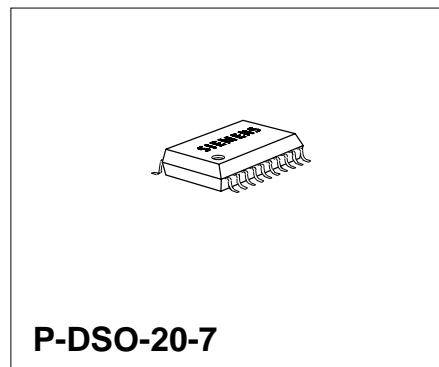

Type	Ordering Code	Package
TLE 4214 G	Q67000-A9094	P-DSO-20-7 (SMD)

### Application

Applications in automotive electronics require intelligent power switches activated by logic signals, which are shorted-load protected and provide error feedback.

This IC contains two of these power switches (low-side switches). In case of inductive loads the integrated clamp diodes clamp the discharging voltage. If a “high” signal is applied to the enable input both switches can be activated independently of one another with TTL signals at the control inputs (active high). The high impedance inputs should always be connected to a fixed potential (noise immunity).

The status output (open collector) signals the following malfunctions with high potential:

- Overload,
- Open load,
- Shorted load to ground,
- Overvoltage,
- Overtemperature.

## Pin Configuration (top view)

### TLE 4214 G

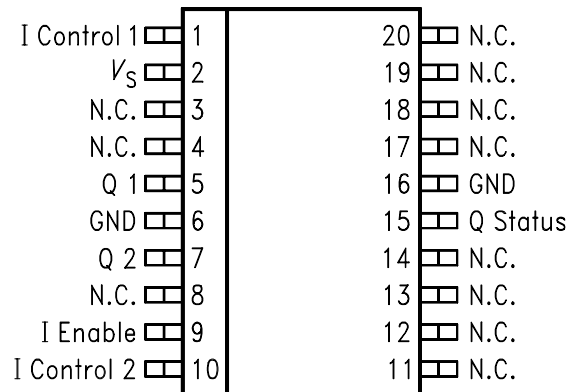

AEP01080

## Pin Definitions and Functions

Pin No.	Symbol	Function
6, 16	GND	<b>Ground</b> Design wiring for the max. short-circuit current (2 x 1 A)
10	IN2	<b>Control input 2</b> (TTL compatible) activates the output transistor 2 in case of high potential
2	V <sub>S</sub>	<b>Supply voltage</b> In case of overvoltage at this pin large sections of the circuit are deactivated. The status output indicates this malfunction without delay time.
7	Q2	<b>Output 2</b> Shorted load protected, open collector output for currents up to 0.5 A, with clamping diodes to supply voltage.
5	Q1	<b>Output 1</b> Shorted load protected, open collector output for currents up to 0.5 A, with clamping diodes to supply voltage.
9	ENA	<b>Enable input</b> , active high
1	IN1	<b>Control input 1</b> (TTL-compatible) activates output transistor 1 in case of high potential
15	STA	<b>Status output</b> (open collector) for both outputs; indicates overtemperature, overload, open load and shorted load to ground as well as overvoltage at pin 3. It is switched to high after a defined delay time in case of malfunction (except: overvoltage)
3, 4, 8, 11 ... 14, 17 ... 20	N. C.	Not connected

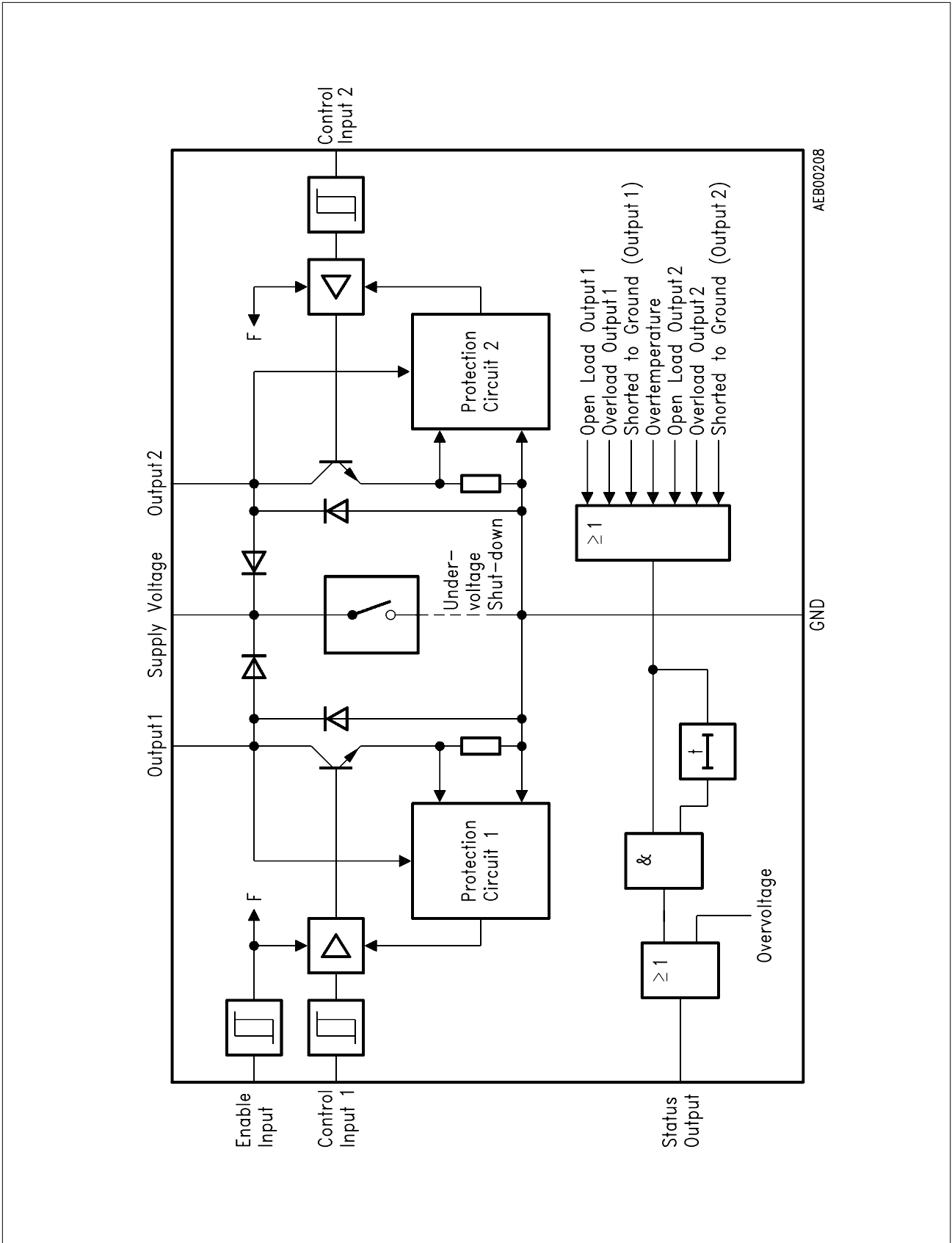

Block Diagram

## Circuit Description

### Input Circuits

The control inputs and the enable input consist of TTL-compatible Schmitt triggers with hysteresis. Controlled by these stages the buffer amplifiers drive the NPN power transistors.

### Switching Stages

The output stages consist of NPN power transistors with open collectors. Since the protective circuit allocated to each stage limits the power dissipation, the outputs are shorted-load protected to the supply voltage throughout the entire operating range. Positive voltage peaks, which occur during the switching of inductive loads, are limited by the integrated clamp diodes.

### Monitoring and Protective Functions

During the activated status the outputs are monitored for open load, overload, and shorted load to ground (see table below). In addition, large sections of the circuit are shut down in case of excessive supply voltages  $V_S$ . Linked via OR gate the information regarding these malfunctions effects the status output (open collector, active high). An internally determined delay time applied to all malfunctions but overvoltage prevents the output of messages in case of short-term malfunctions. Furthermore, a temperature protection circuit prevents thermal overload. If overload occurs, the outputs are protected according to the safe operating area (SOA) mode (**see diagram**). If voltage and current are outside the SOA, the outputs oscillate to reduce the power dissipation. The switching frequency depends on the internal delay time and the external load (inductances and capacitances). If the frequency is low, the status output may follow the oscillation. An integrated reverse diode protects the supply voltage  $V_S$  against reverse polarities. Similarly the load circuit is protected against reverse polarities within the limits established by the maximum ratings (no shorted load at the same time!). At supply voltages below the operating range an undervoltage detector ensures that neither the status nor the outputs are activated. At supply voltages below the operating range the output stages are de-activated.

### Status Output (H = Error)

	Undervoltage > 3.5 V	Operating Range		Overvoltage
		V <sub>I</sub> = L (passive)	V <sub>I</sub> = H (active)	
Normal function	L	L	L	H
Overload	L	L	H	H
Open load	L	L	H	H
Shorted output to ground	L	H	H	H
Overtemperature	L	H	H	H

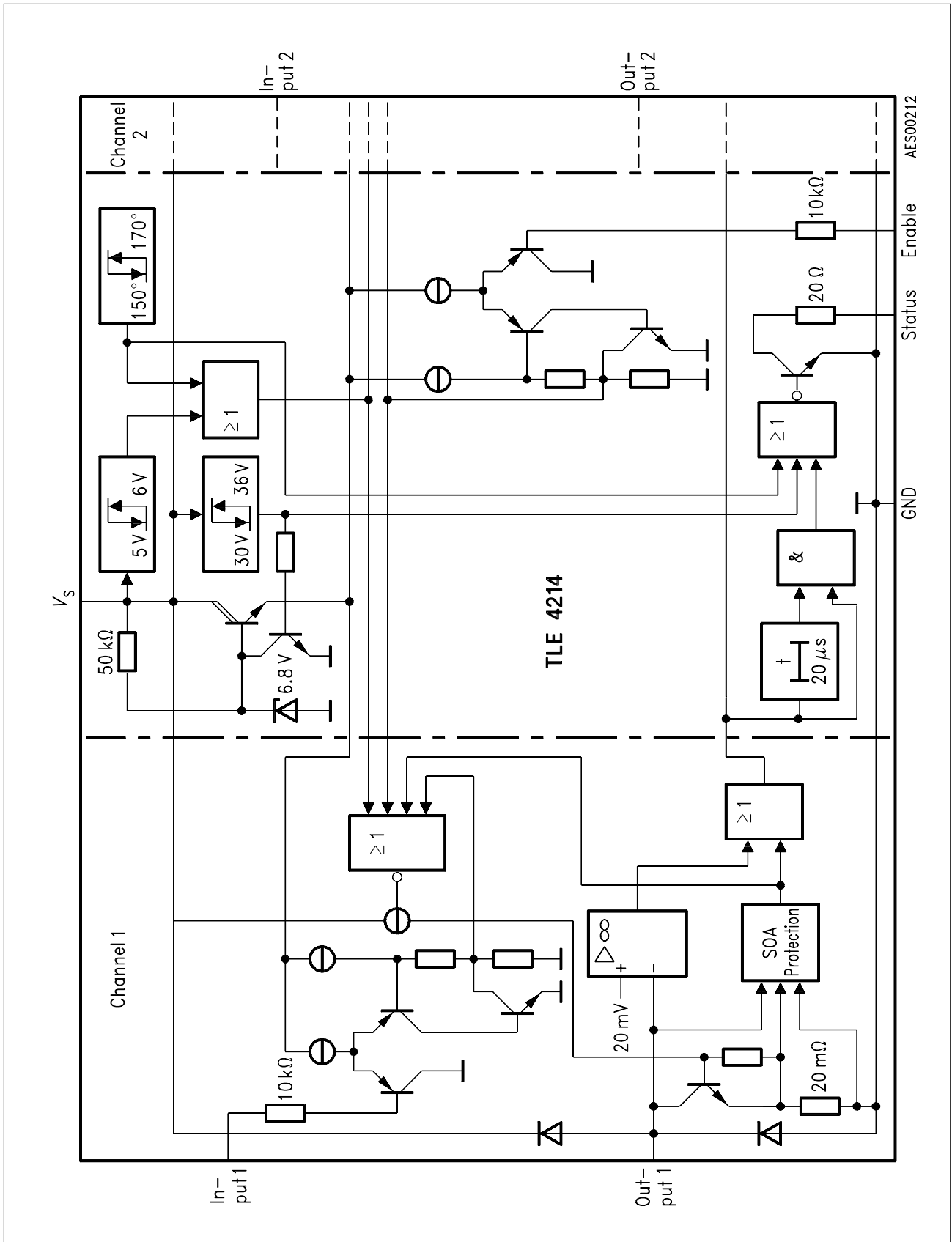

Circuit Diagram

## Absolute Maximum Ratings

$T_j = -40$  to  $150$  °C

Parameter	Symbol	Limit Values		Unit
		min.	max.	

## Voltages

Supply voltage, $t < 0.2$ s	$V_S$	–	70	V
Supply voltage	$V_S$	– 1.3	40	V
Input voltage	$V_I$	– 13	40	V
Output voltage (status output)	$V_O$	– 0.3	40	V
Output voltage (switching stages)	$V_Q$	– 0.3	+ $V_S$	V

## Currents

Output current (switching stages)	$I_Q$	internally limited	–	–
Current with reverse polarity, $t < 0.1$ s	$I_Q$	– 0.7	–	A
Output current positive clamp	$I_Q$	–	0.7	A
Ground current	$I_{GND}$	– 1.4	2.0	A
Output current (status output)	$I_O$	–	10	mA
Junction temperature	$T_j$	–	150	°C
Storage temperature	$T_{stg}$	– 50	150	°C

## Operating Range

Supply voltage	$V_S$	6 <sup>1)</sup>	25	V
Supply voltage slew rate	$dV_S/dt$	– 1	1	V/ $\mu$ s
Output current (switching stages)	$I_Q$	– 0.5	0.5	A
Input voltage	$V_I, V_F$	– 5	32	V
Output current (status output)	$I_O$	0	5	mA
Ambient temperature	$T_A$	– 40	125	°C

<sup>1)</sup> Lower limit = 5 V, if previously  $V_S$  greater than 6 V (turn-on hysteresis)



## Absolute Maximum Ratings (cont'd)

$T_j = -40$  to  $150$  °C

Parameter	Symbol	Limit Values		Unit
		min.	max.	
Supply voltage while shorted load	$V_S$	–	15	V
Thermal resistance junction to ambient	$R_{th JA}$	–	77	K/W

## Characteristics

$V_S = 6$  to  $16$  V (typ.  $V_S = 12$  V);  $T_j = -40$  to  $150$  °C (typ.  $T_j = 25$  °C)

Parameter	Symbol	Limit Values			Unit	Test Condition
		min.	typ.	max.		

## General Characteristics

Quiescent current	$I_S$	–	2	4	mA	$V_F < V_{FL}$
Supply voltage	$I_S$	–	35	50	mA	$V_I = V_I > V_{IH}, V_F > V_{FH}$
Supply overvoltage shutdown threshold	$V_{SO}$	30	37	42	V	$V_L = 5$ V; $V_O > 4.5$ V
Hysteresis of supply overvoltage shutdown threshold	$\Delta V_{SO}$	4	6	9	V	$V_L = 5$ V; $V_O > 4.5$ V
Open load error threshold voltage	$V_Q$	5	20	50	mV	$V_L = 5$ V; $V_O > 4.5$ V
Open load error threshold current	$I_{QU}$	1	–	40	mA	$V_Q = V_{QU}$
Open load error threshold current for both channels active	$I_{QU}$	–	–	80	mA	$V_{Q1} = V_{Q2} = V_{QU}$

## Characteristics (cont'd)

$V_S = 6$  to  $16$  V (typ.  $V_S = 12$  V);  $T_j = -40$  to  $150$  °C (typ.  $T_j = 25$  °C)

Parameter	Symbol	Limit Values			Unit	Test Condition
		min.	typ.	max.		

## Logic

Control inputs						
H-input voltage threshold	$V_{IH}$	1.3	1.8	2.1	V	–
L-input voltage threshold	$V_{IL}$	0.9	1.2	1.5	V	–
Hysteresis of control input voltage	$\Delta V_I$	0.2	0.6	1.0	V	–
Enable input						
H-input voltage threshold	$V_{FH}$	1.6	2.1	2.7	V	–
L-input voltage threshold	$V_{FL}$	1.4	1.8	2.3	V	–
Hysteresis of enable input voltage	$\Delta V_F$	0.1	0.3	0.7	V	–
H-input current	$I_{IH}$	0	–	10	$\mu$ A	$V_I = 5$ V
L-input current	$-I_{IL}$	0	–	10	$\mu$ A	$V_I = 0.5$ V

## Status Output (open collector)

L-saturation voltage	$V_{osat}$	0.1	0.2	0.4	V	$I_O = 5$ mA
Status delay time	$t_{dS}$	8	20	32	$\mu$ s	<sup>1)</sup>

<sup>1)</sup> Period from the beginning of the disturbance at one channel (exception: overvoltage) until the 50 % value of the status switching edge is reached.

## Characteristics (cont'd)

$V_S = 6$  to  $16$  V (typ.  $V_S = 12$  V);  $T_j = -40$  to  $150$  °C (typ.  $T_j = 25$  °C)

Parameter	Symbol	Limit Values			Unit	Test Condition
		min.	typ.	max.		

## Switching Stages

Saturation voltage	$V_{QSat}$	–	0.6	0.8	V	$I_Q = 0.5$ A; $V_I > V_{IH}$ ; $V_F > V_{FH}$
Saturation voltage	$V_{QSat}$	–	45	100	mV	$I_Q = 50$ mA; $V_I > V_{IH}$ ; $V_F > V_{FH}$
Output current	$I_Q$	0.5	–	–	A	$V_{QSat} = 0.8$ V; $V_I > V_{IH}$
Leakage current	$I_Q$	–5	–	50	$\mu$ A	$V_Q = 6$ V; $V_I < V_{IL}$
Switch-ON time	$t_{D ON}$	0.2	0.5	5	$\mu$ s	$I_Q = 0.5$ A <b>see Timing</b>
Switch-OFF time	$t_{D OFF}$	0.2	2	5	$\mu$ s	$I_Q = 0.5$ A <b>Diagram</b>
Forward voltage of substrate diode	$V_{QS}$	–	1.3	1.7	V	$I_Q = -0.5$ A $t < 0.1$ s
Forward voltage of clamp diode	$V_{QF}$	–	1.3	1.7	V	$I_Q = 0.5$ A $t < 0.1$ s
Leakage current of clamp diode	$-I_{QF}$	–	–	5	$\mu$ A	$V_Q = 0$ V; $V_I < V_{IL}$

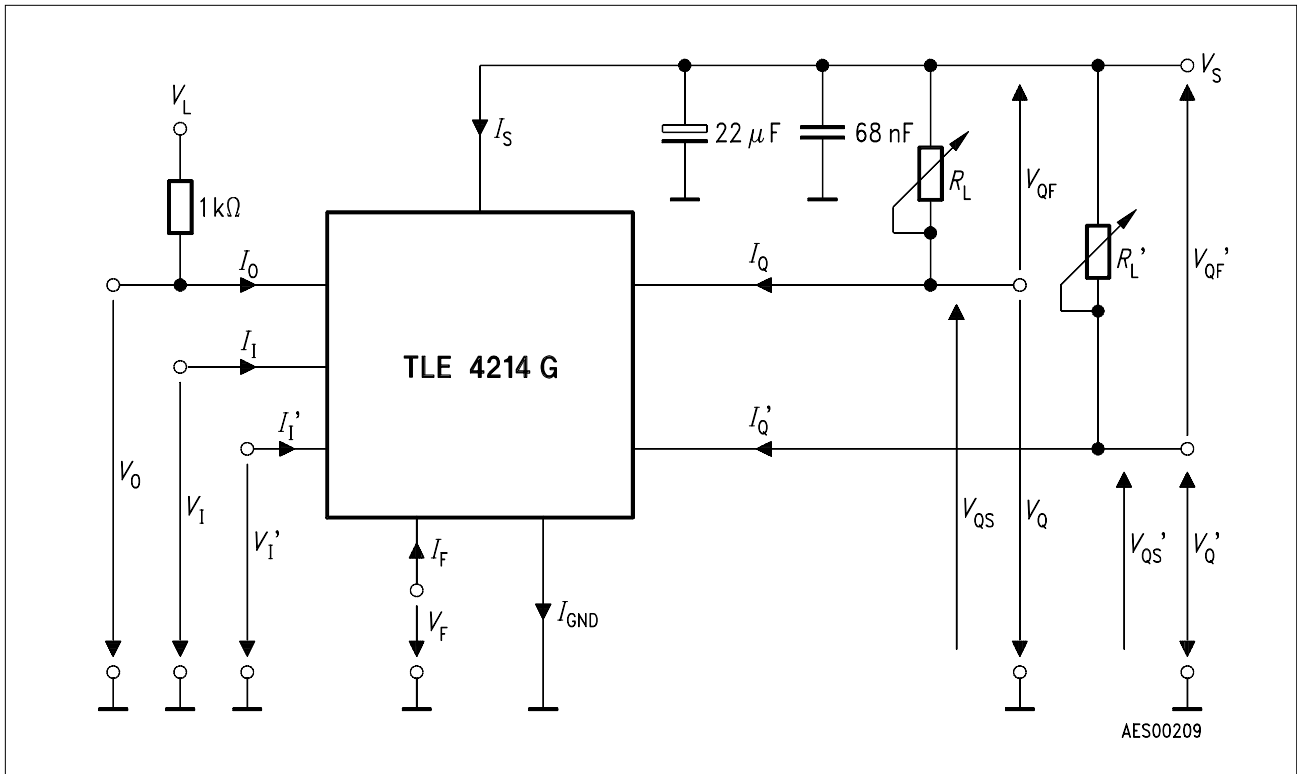

**Test Circuit**

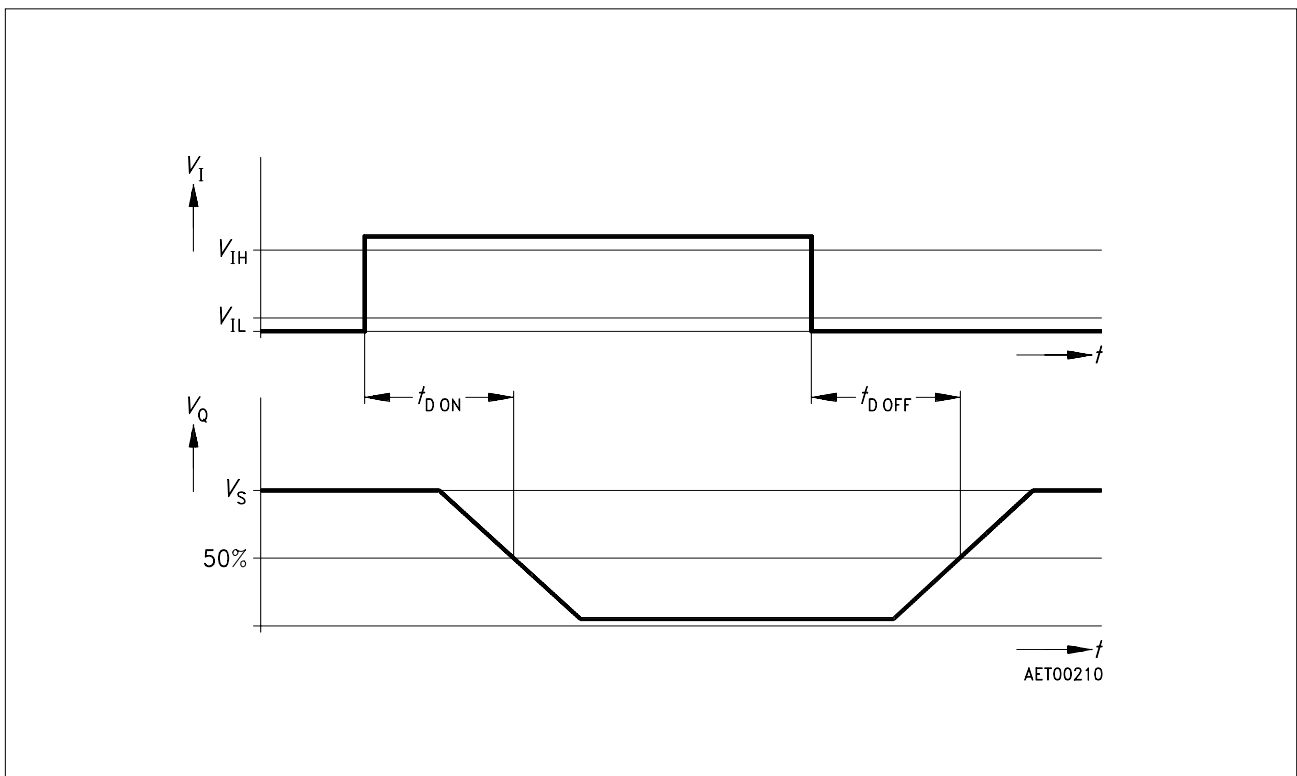

**Timing Diagram**

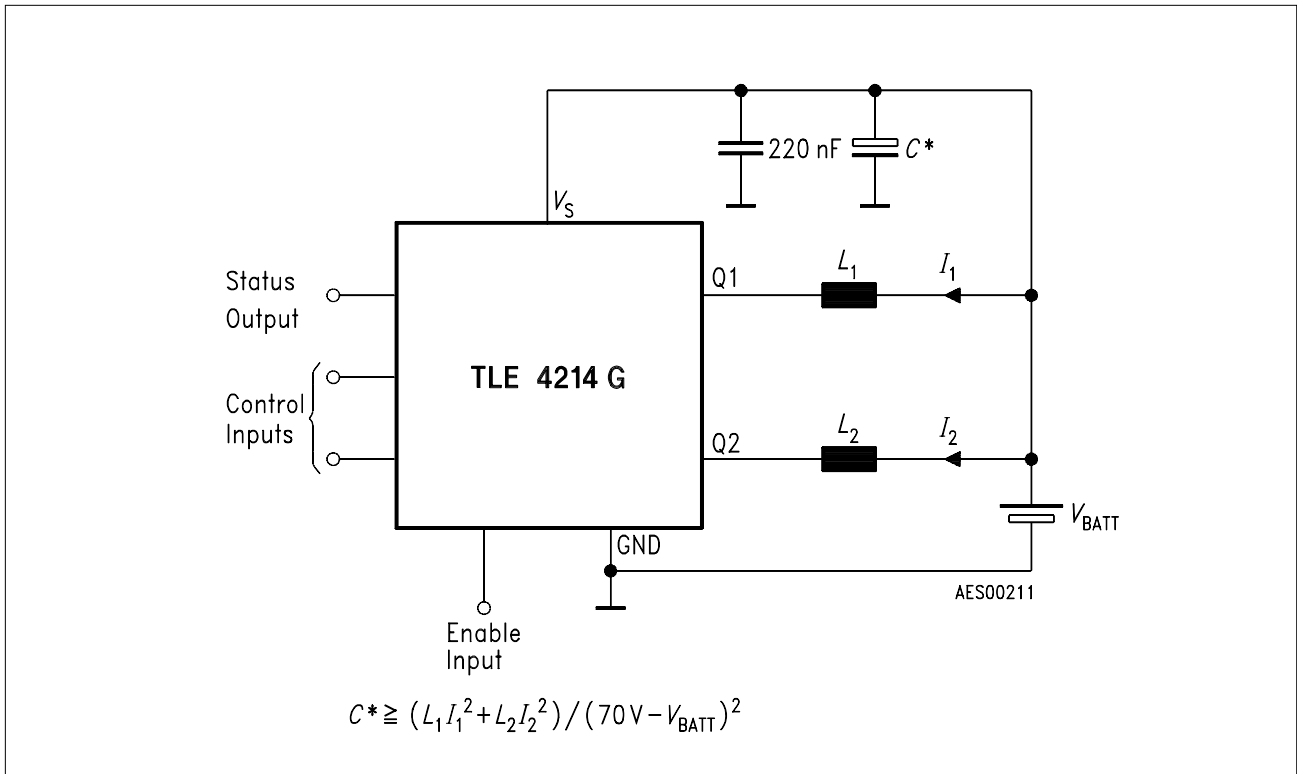

Application Circuit

### Quiescent Current $I_S$ versus Ambient Temperature $T_A$ in the OFF-Status

$V_S = 12\text{ V}; V_F < V_{FL}$

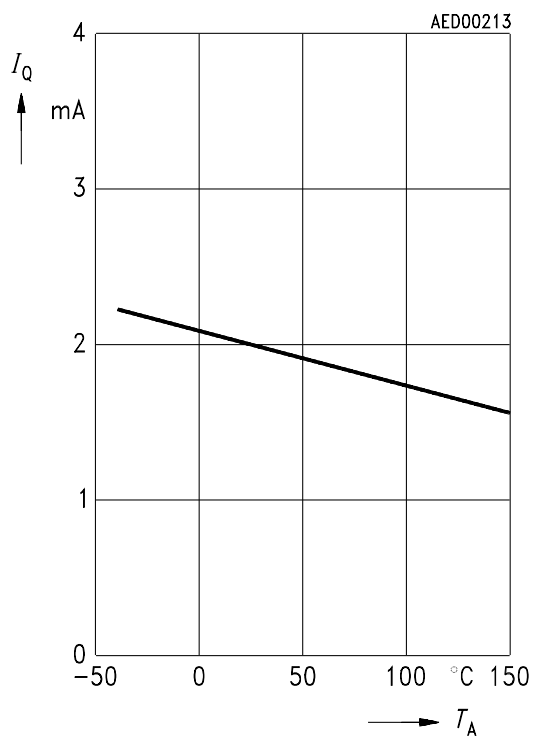

### Shorted Load Current $I_{Q0}$ versus Output Voltage $V_Q$

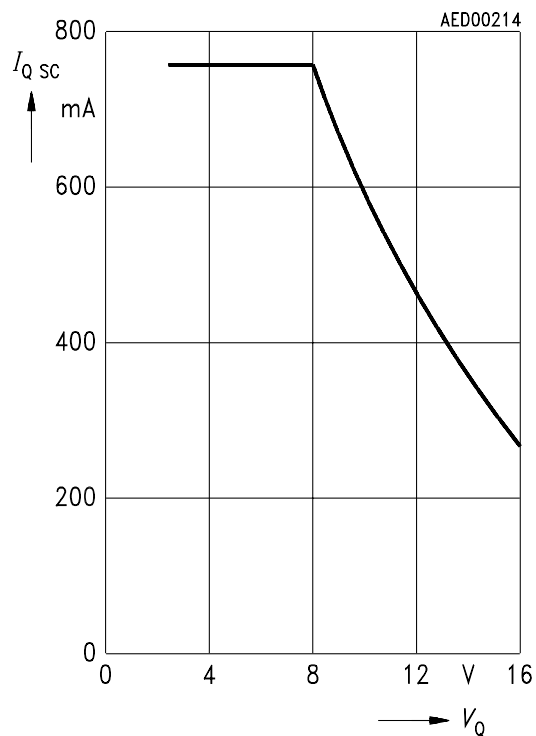

### Output Voltage $V_Q$ versus Output Current $V_S = 12\text{ V}; V_I > V_{IH}$

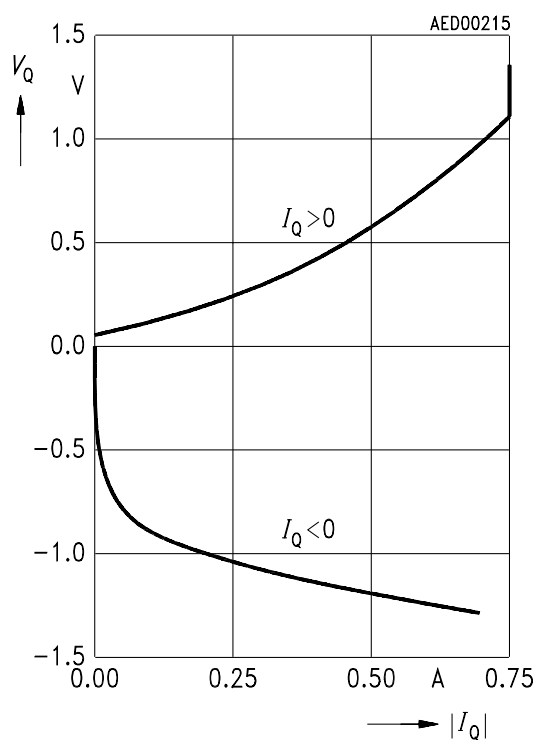

### Equal current at both channels

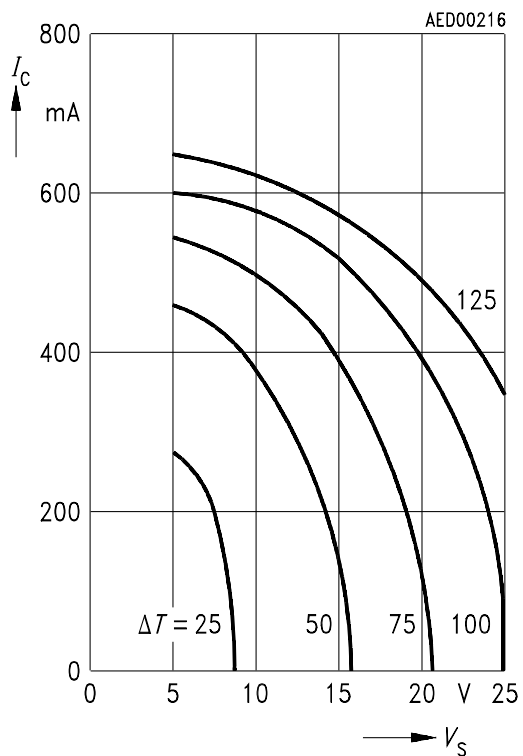

### First channel 50 mA, second channel $I_Q$

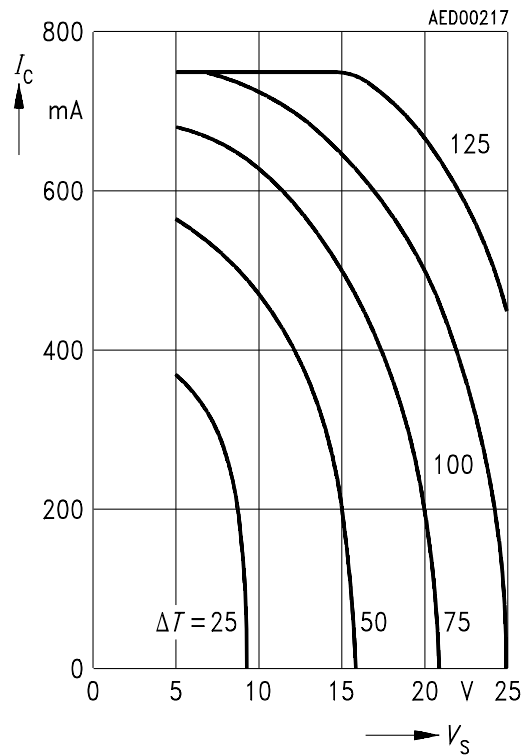

### Only one channel in operation

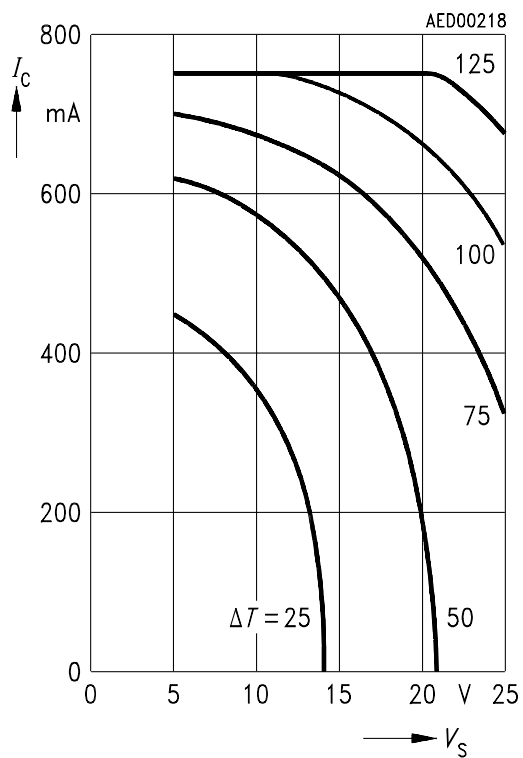

## Package Outlines

### P-DSO-20-7 (Plastic Dual Small Outline Package)

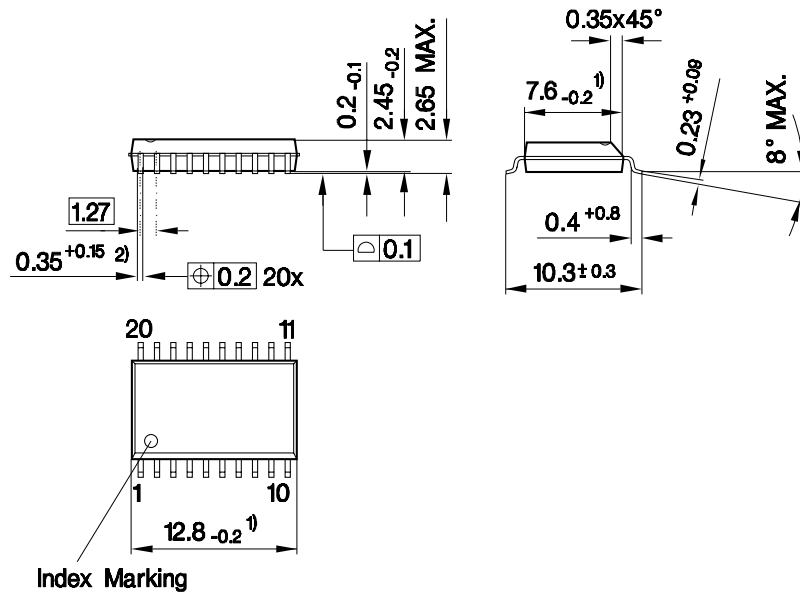

- Index Marking
- 1) Does not include plastic or metal protrusion of 0.15 max. per side
  - 2) Does not include dambar protrusion of 0.05 max. per side

GPSO5094

### Sorts of Packing

Package outlines for tubes, trays etc. are contained in our Data Book "Package Information".

SMD = Surface Mounted Device

Dimensions in mm