

TLE9461ES

Lite CAN SBC Family



RoHS



1 Overview

Features

Key Features

- Very low quiescent current consumption in Stop- and Sleep Mode
- Periodic Cyclic Wake in SBC Normal-, Stop- and Sleep Mode
- Periodic Cyclic Sense in SBC Normal-, Stop- and Sleep Mode
- Low-Drop Linear Voltage Regulator 5 V, 150 mA (250 mA peak) for main supply,
- Low-Drop Linear Voltage Regulator 5 V, 100 mA, protection feature for off-board usage
- High-Speed CAN transceiver supporting FD communication up to 5 Mbit/s according to ISO 11898-2:2016 & SAE J2284
- Fully compliant to “Hardware Requirements for LIN, CAN and FlexRay Interfaces in Automotive Applications” Revision 1.3, 2012-05-04
- Charge pump-output for N-channel MOSFET reverse-polarity protection or load switch feature with integrated spread spectrum modulation feature for optimum EMC performance
- Universal High-Voltage Wake input for voltage level monitoring and wake-up detection
- General Purpose High-Voltage in- and output (GPIO) configurable as Fail Output, Wake Input, Low-Side switch or High-Side switch
- High-Voltage Measurement function as alternative pin assignment
- Fail Output for Fail-Safe signalization
- Configurable wake-up sources
- Reset & Interrupt outputs
- Configurable timeout and window watchdog
- Overtemperature and short circuit protection feature
- Dedicated TEST pin for SBC Development Mode entry (watchdog counter stopped)
- Software compatible to other SBC families TLE926x and TLE927x
- Wide input voltage and temperature range
- Optimized for Electromagnetic Compatibility (EMC) and low Electromagnetic Emission (EME)
- Optimized for high immunity against Electromagnetic Interference (EMI)
- AEC Qualified & Green Product (RoHS compliant)

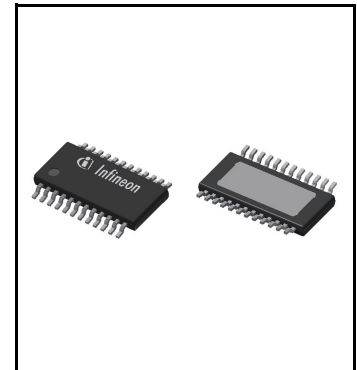

Overview

Scalable System Basis Chip (SBC) Family

- Product family for complete scalable application coverage
- Optimized feature set for optimal system design
- Dedicated Data Sheets are available for all product variants
- Complete compatibility (hardware- and software across the family)
- Same PG-TSDSO-24-1 package with exposed pad (EP) for all product variants
- CAN Partial Networking variants (-3ES)
- Product variants for 5 V (TLE94xxyy) and 3.3 V (TLE94xxyyV33) output voltage for main regulator
- Software compatible to other SBC families TLE926x and TLE927x

Potential applications

- HVAC ECU and Control panel
- Light Control Unit (LCU) for front, rear and ambient
- Seat control module
- Seat belt pretension
- Steering column and steering lock
- Closure (trunk, sliding door, etc.)
- Gear shifters and selectors
- Smart power distribution modules

Product validation

Qualified for automotive applications. Product validation according to AEC-Q100/101.

Description

The TLE9461ES is a monolithically integrated circuit in an exposed pad PG-TSDSO-24-1 (150 mil) power package. The device is designed for various CAN automotive applications as main supply for the microcontroller and as interface for a CAN bus network.

To support these applications, the System Basis Chip (SBC) provides the main functions, such as a 5 V low-dropout voltage regulator (LDO) for e.g. a microcontroller supply, another 5 V low-dropout voltage regulator with off-board protection for e.g. sensor supply, a HS-CAN transceiver supporting CAN FD for data transmission, a high-voltage GPIO with embedded protective functions and a 16-bit Serial Peripheral Interface (SPI) to control and monitor the device. Also a configurable timeout / window watchdog circuit with a reset feature, one dedicated fail output and an undervoltage reset feature are implemented.

The device offers low-power modes in order to minimize current consumption in applications that are connected permanently to the battery. A wake-up from the low-power mode is possible via a message on the CAN bus, via the bi-level sensitive monitoring/wake-up input as well as via Cyclic Wake.

The device is designed to withstand the severe conditions of automotive applications

Type	Package	Marking
TLE9461ES	PG-TSDSO-24-1	TLE9461ES

Table of Contents

1	Overview	1
2	Block Diagram	6
3	Pin Configuration	7
3.1	Pin Assignment	7
3.2	Pin Definitions and Functions	7
3.3	Hints for Unused Pins	9
3.4	Hints for Alternative Pin Functions	9
4	General Product Characteristics	10
4.1	Absolute Maximum Ratings	10
4.2	Functional Range	12
4.3	Thermal Resistance	13
4.4	Current Consumption	14
5	System Features	18
5.1	Block Description of State Machine	19
5.1.1	Device Configuration and SBC Init Mode	20
5.1.1.1	Device Configuration	20
5.1.1.2	SBC Init Mode	23
5.1.2	SBC Normal Mode	24
5.1.3	SBC Stop Mode	25
5.1.4	SBC Sleep Mode	26
5.1.5	SBC Restart Mode	27
5.1.6	SBC Fail-Safe Mode	28
5.1.7	SBC Development Mode	29
5.1.8	Electrical Characteristics for Pin TEST	31
5.2	Wake Features	32
5.2.1	Cyclic Sense	32
5.2.1.1	Configuration and Operation of Cyclic Sense	33
5.2.1.2	Cyclic Sense in Low-Power Mode	36
5.2.2	Cyclic Wake	36
5.2.3	Internal Timer	37
5.3	Charge Pump Output for Reverse Polarity Protection	38
5.3.1	Electrical Characteristics for Charge Pump	39
5.4	High-Voltage Measurement Interface	40
5.4.1	Block Description	40
5.4.2	Functional Description	40
5.4.3	Electrical Characteristics for Measurement Interface	42
5.5	Spread Spectrum Modulation Frequency Function	43
6	Voltage Regulator 1	44
6.1	Block Description	44
6.2	Functional Description	45
6.3	Electrical Characteristics	46
7	Voltage Regulator 2	48
7.1	Block Description	48
7.2	Functional Description	49

7.2.1	Short to Battery Protection	49
7.3	Electrical Characteristics	50
8	High-Speed CAN FD Transceiver	53
8.1	Block Description	53
8.2	Functional Description	53
8.2.1	CAN Off Mode	55
8.2.2	CAN Normal Mode	55
8.2.3	CAN Receive Only Mode	56
8.2.4	CAN Wake Capable Mode	56
8.2.5	CAN Bus termination	57
8.2.6	TXD Time-out Feature	57
8.2.7	Bus Dominant Clamping	58
8.2.8	Undervoltage Detection	58
8.3	Electrical Characteristics	59
9	High-Voltage Wake and Voltage Monitoring Input	66
9.1	Block Description	66
9.2	High-Voltage Wake Function	67
9.2.1	Functional Description	67
9.2.2	Wake Input Configuration	68
9.2.3	Wake configuration for Cyclic Sense	69
9.2.4	High-Voltage Sensing as Alternate Function	69
9.3	Electrical Characteristics	70
10	Interrupt Function	71
10.1	Block and Functional Description	71
10.2	Electrical Characteristics	73
11	Fail Output (FO) and General Purpose I/O (GPIO)	74
11.1	Block and Functional Description	74
11.1.1	Fail-Output Function	75
11.1.2	General Purpose I/O Function as Alternative Function	76
11.1.3	WK and FO/GPIO HV-Sensing Function as Alternative Function	79
11.2	Electrical Characteristics	80
12	Supervision Functions	82
12.1	Reset Function	82
12.1.1	Reset Output Description	82
12.1.2	Soft Reset Description	83
12.2	Watchdog Function	84
12.2.1	Time-Out Watchdog	85
12.2.2	Window Watchdog	85
12.2.3	Watchdog Setting Check Sum	86
12.2.4	Watchdog during SBC Stop Mode	86
12.2.5	Watchdog Start in SBC Stop Mode due to Bus Wake	87
12.3	VS Power-On Reset	88
12.4	VS Under- and Overvoltage	89
12.4.1	VS Undervoltage	89
12.4.2	VS Overvoltage	89
12.5	VCC1 Over-/ Undervoltage and Undervoltage Prewarning	89

12.5.1	VCC1 Undervoltage and Undervoltage Prewarning	89
12.5.2	VCC1 Overvoltage	90
12.6	VCC1 Short Circuit Diagnostics	91
12.7	VCC2 Undervoltage and VCAN Undervoltage	91
12.8	Thermal Protection	92
12.8.1	Individual Thermal Shutdown	92
12.8.2	Temperature Prewarning	92
12.8.3	SBC Thermal Shutdown	92
12.9	Electrical Characteristics	93
13	Serial Peripheral Interface	97
13.1	SPI Block Description	97
13.2	Failure Signalization in the SPI Data Output	98
13.3	SPI Programming	99
13.4	SPI Bit Mapping	101
13.5	SPI Control Registers	104
13.5.1	General Control Registers	106
13.6	SPI Status Information Registers	118
13.6.1	General Status Registers	119
13.6.2	Family and Product Information Register	126
13.7	Electrical Characteristics	127
14	Application Information	129
14.1	Application Diagrams	129
14.2	ESD Tests	135
14.3	Thermal Behavior of Package	136
14.4	Further Application Information	137
15	Package Outlines	138
16	Revision History	139

Block Diagram

2 Block Diagram

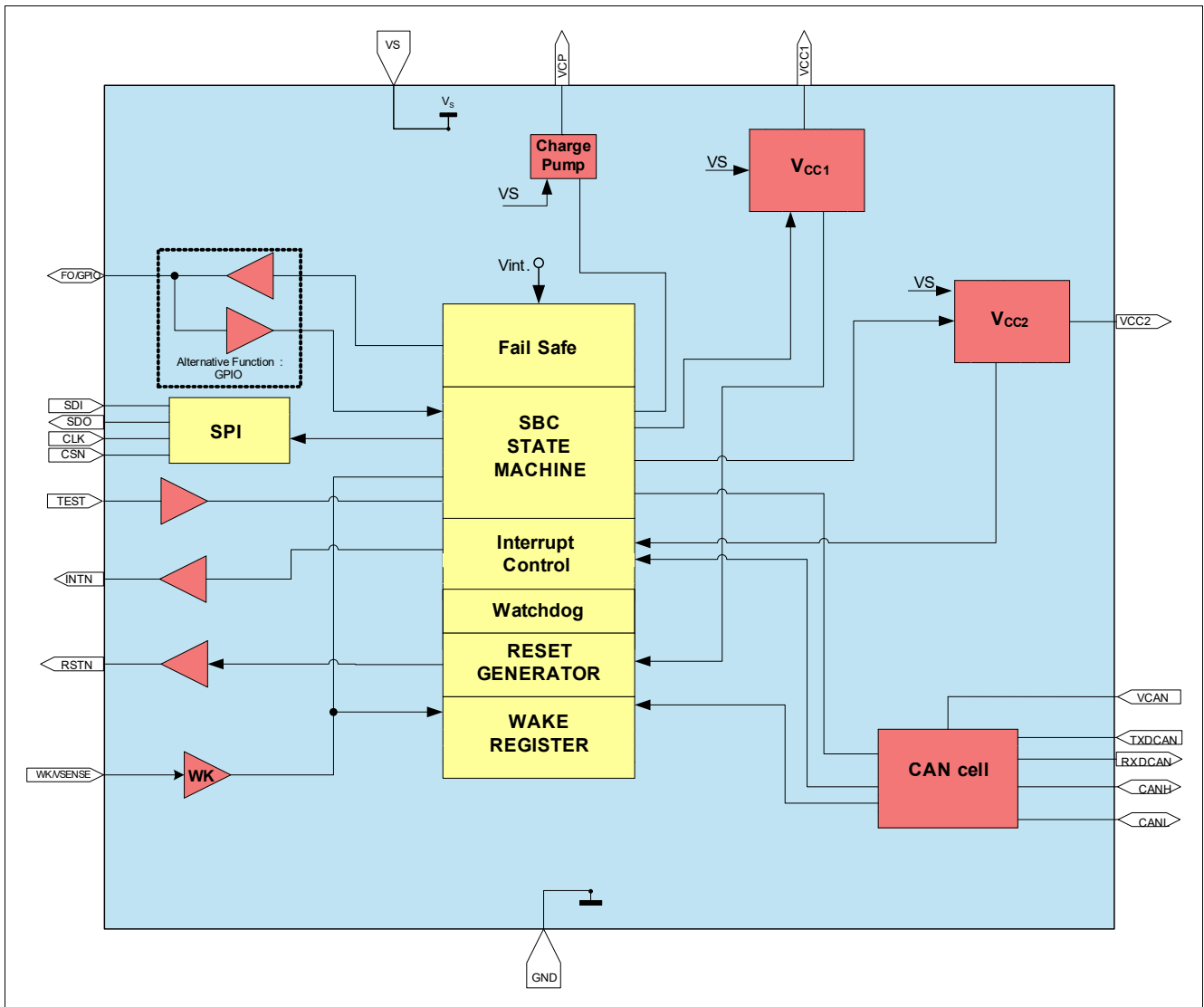

Figure 1 TLE9461ES Block Diagram

Pin Configuration

3 Pin Configuration

3.1 Pin Assignment

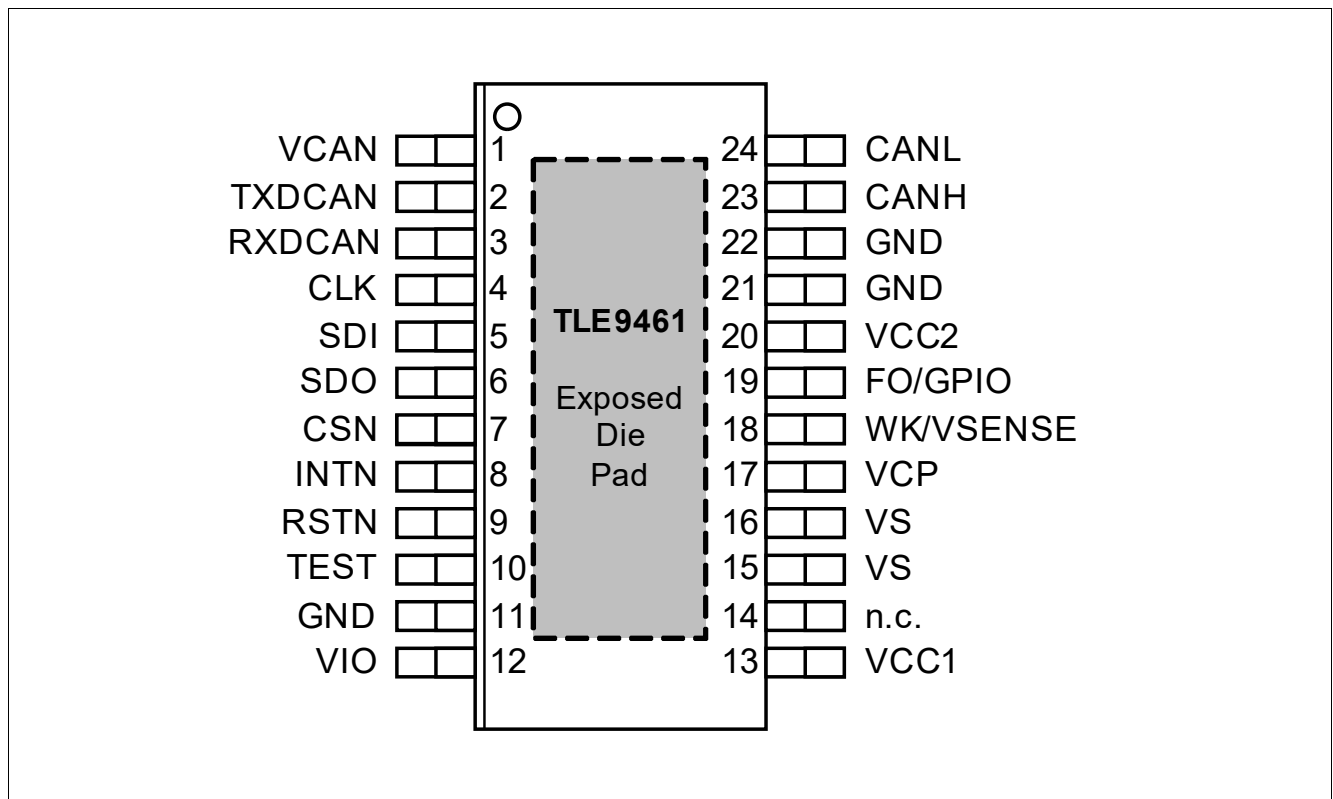

Figure 2 Pin Configuration

3.2 Pin Definitions and Functions

Pin	Symbol	Function
1	VCAN	HS-CAN Supply Input; Supply needed for CAN Normal and Receive Only Mode
2	TXDCAN	Transmit CAN
3	RXDCAN	Receive CAN
4	CLK	SPI Clock Input
5	SDI	SPI Data Input; input for SBC (=MOSI)
6	SDO	SPI Data Output; output from SBC (=MISO)
7	CSN	SPI Chip Select Input; active low
8	INTN	Interrupt Output; used as wake-up flag for microcontroller in SBC Stop or Normal Mode and for indicating failures. Active low. During start-up used to set the SBC configuration in case of watchdog trigger failure. External pull-up (typ. 47 kΩ) sets config 1/3, otherwise config 2/4 is selected.

Pin Configuration

Pin	Symbol	Function
9	RSTN	Reset Output; active low, internal pull-up
10	TEST	Test Pin; Connect to GND or leave open for normal user mode operation; Connect to VCC1 at device power-on to activate SBC Development Mode (see Chapter 5.1.7). Integrated pull-down resistor.
11	GND	Ground; LDO 1 Power GND
12	VIO	Digital I/O Pin Voltage Supply; Must be connected to the buffered VCC1 voltage (see also Figure 44)
13	VCC1	Voltage Regulator 1 Output
14	n.c.	not connected; internally not bonded
15	VS	Supply Voltage; Supply for VCC1 power stage - both VS pins must be connected together on same battery potential for proper operation; Connect to battery voltage via reverse polarity protection diode and filter against EMC
16	VS	Supply Voltage; Main supply of device - both VS pins must be connected together on same battery potential for proper operation; Connect to battery voltage via reverse polarity protection diode and filter against EMC
17	VCP	Charge Pump Output; For driving the gate of external N-channel MOSFETs, e.g. for reverse polarity protection or Kl.30 load switch. Always place a 1kΩ resistor in series for protection
18	WK/VSENSE	Wake Input; Sense Input; Alternative function: HV-measurement function input
19	FO/GPIO	Fail Output; Open Drain Output, active low; GPIO; Alternative function: configurable pin as WK, LS-, or HS-witch supplied by VS (default is FO, see also Chapter 11.1.1) Sense Output; Alternative function: if HV-measurement function is configured
20	VCC2	Voltage Regulator 2 Output
21	GND	Ground; Analog GND
22	GND	Ground; CAN GND
23	CANH	CAN High Bus Pin
24	CANL	CAN Low Bus Pin
Cooling Tab	GND	Cooling Tab - Exposed Die Pad; For cooling purposes only, connect to but do not use as an electrical ground ¹⁾

1) The exposed die pad at the bottom of the package allows better power dissipation of heat from the SBC via the PCB. The exposed die pad is not connected to any active part of the IC. However, it should be connected to GND for the best EMC performance.

*Note: Both VS Pins must be connected to same battery potential;
all GND pins as well as the Cooling Tab must be connected to one common GND potential*

Pin Configuration

3.3 Hints for Unused Pins

In case functions or pins are not used, it must be ensured that the configurations are done properly, e.g. disabled via SPI. Unused pins should be handled as follows:

- WK/VSENSE: connect to GND and disable WK inputs via SPI
- RSTN / INTN / FO: leave open
- VCC2: leave open and keep disabled
- VCAN: connect to VCC1
- CANH/L, RXDCAN, TXDCAN: leave all pins open
- TEST: Leave open or connect to GND for normal user mode operation or connect to VIO to activate SBC Development Mode;
- **n.c.:** not connected; internally not bonded; leave open
- If unused pins are routed to an external connector which leaves the ECU, then these pins should have provision for a jumper (depopulated if unused)

3.4 Hints for Alternative Pin Functions

In case of SPI selectable alternative pin functions, it must be ensured that the correct configurations are also selected via SPI (in case it is not done automatically). Please consult the respective chapter. In addition, following topics shall be considered:

- WK/VSENSE: The pin can be either used as high-voltage wake-up and monitoring function or for a voltage measurement function (via bit setting **WK_MEAS** = '1'). In the second case, the WK pin shall not be used / assigned for any wake-up detection nor Cyclic Sense functionality, i.e. WK must be disabled in the register **WK_CTRL_1** and the level information must be ignored in the register **WK_LVL_STAT**.
- FO/GPIO: The pin can also be configured as a GPIO in the **GPIO_CTRL** register. In this case, the pin shall not be used for any fail output functionality.

The default configuration after start-up or power on reset (POR) is FO.

General Product Characteristics

4 General Product Characteristics

4.1 Absolute Maximum Ratings

Table 1 Absolute Maximum Ratings¹⁾

$T_j = -40^\circ\text{C}$ to $+150^\circ\text{C}$; all voltages with respect to ground, positive current flowing into pin (unless otherwise specified)

Parameter	Symbol	Values			Unit	Note or Test Condition	Number
		Min.	Typ.	Max.			
Voltages							
Supply Voltage VS	$V_{S, \max}$	-0.3	-	28	V	-	P_4.1.1
Supply Voltage VS	$V_{S, \max}$	-0.3	-	40	V	Load Dump, max. 400 ms	P_4.1.2
Voltage Regulator 1 Output	$V_{CC1, \max}$	-0.3	-	5.5	V	²⁾	P_4.1.3
Voltage Regulator 2 Output	$V_{CC2, \max}$	-0.3	-	28	V	$V_{CC2} = 40\text{ V}$ for Load Dump, max. 400 ms;	P_4.1.5
Charge Pump Output	$V_{CP, \max}$	-0.3	-	$V_S + 16$	V		P_4.1.6
Wake Input WK/VSENSE	$V_{WK, \max}$	-0.3	-	40	V	-	P_4.1.7
Fail Output FO/GPIO	$V_{FO_TEST, \max}$	-0.3	-	$V_S + 0.3$	V	-	P_4.1.8
CANH, CANL	$V_{BUS, \max}$	-27	-	40	V	-	P_4.1.9
Logic Input Pins (CSN, CLK, SDI, TXDCAN, TEST)	$V_{I, \max}$	-0.3	-	$V_{CC1} + 0.3$	V	-	P_4.1.10
Logic Output Pins (SDO, RSTN, INTN, RXDCAN)	$V_{O, \max}$	-0.3	-	$V_{CC1} + 0.3$	V	-	P_4.1.11
VCAN Input Voltage	$V_{VCAN, \max}$	-0.3	-	5.5	V	-	P_4.1.12
I/O Supply Voltage	$V_{VIO, \max}$	-0.3	-	5.5	V	Must be connected to VCC1	P_4.1.19
Maximum Differential CAN Bus Voltage	$V_{CAN_Diff, \max}$	-5	-	10	V	-	P_4.1.20
Temperatures							
Junction Temperature	T_j	-40	-	150	$^\circ\text{C}$	-	P_4.1.13
Storage Temperature	T_{stg}	-55	-	150	$^\circ\text{C}$	-	P_4.1.14
ESD Susceptibility							
ESD Resistivity	$V_{ESD,11}$	-2	-	2	kV	HBM ³⁾	P_4.1.15
ESD Resistivity to GND, CANH, CANL	$V_{ESD,12}$	-8	-	8	kV	HBM ⁴⁾³⁾	P_4.1.16

General Product Characteristics

Table 1 Absolute Maximum Ratings¹⁾ (cont'd)

$T_j = -40^{\circ}\text{C}$ to $+150^{\circ}\text{C}$; all voltages with respect to ground, positive current flowing into pin (unless otherwise specified)

Parameter	Symbol	Values			Unit	Note or Test Condition	Number
		Min.	Typ.	Max.			
ESD Resistivity to GND	$V_{\text{ESD},21}$	-500	–	500	V	CDM ⁵⁾	P_4.1.17
ESD Resistivity Pin 1, 12,13,24 (corner pins) to GND	$V_{\text{ESD},22}$	-750	–	750	V	CDM ⁵⁾	P_4.1.18

- 1) Not subject to production test, specified by design.
- 2) The VCC1 and digital I/O maximum rating can be 6.0 V for a limited time (up to 100h).
- 3) ESD susceptibility, HBM according to ANSI/ESDA/JEDEC JS-001 (1.5 k Ω , 100 pF)
- 4) Please see chapter “Application Information” For ESD “GUN” resistivity (according to IEC61000-4-2 “gun test” (150 pF, 330 Ω)).
- 5) ESD susceptibility, Charged Device Model “CDM” EIA/JESD22-C101 or ESDA STM5.3.1

Notes

1. Stresses above the ones listed here may cause permanent damage to the device. Exposure to absolute maximum rating conditions for extended periods may affect device reliability.
2. Integrated protection functions are designed to prevent IC destruction under fault conditions described in the data sheet. Fault conditions are considered as “outside” normal operating range. Protection functions are not designed for continuous repetitive operation.

General Product Characteristics

4.2 Functional Range

Table 2 Functional Range¹⁾

Parameter	Symbol	Values			Unit	Note or Test Condition	Number
		Min.	Typ.	Max.			
Supply Voltage	$V_{S,func}$	V_{POR}	–	28	V	²⁾ V_{POR} see section Chapter 12.9	P_4.2.1
CAN Supply Voltage	$V_{CAN,func}$	4.75	–	5.25	V	–	P_4.2.2
SPI Frequency	f_{SPI}	–	–	4	MHz	see Chapter 13.7 for $f_{SPI,max}$	P_4.2.3
Junction Temperature	T_j	-40	–	150	°C	–	P_4.2.4

- 1) Not subject to production test, specified by design.
2) Including Power-On Reset, Over- and Undervoltage Protection

Note: Within the functional range the IC operates as described in the circuit description. The electrical characteristics are specified within the conditions given in the related electrical characteristics table.

Device Behavior Outside of Specified Functional Range:

- $28V < V_{S,func} < 40V$: Device is still functional (including the state machine); the specified electrical characteristics might not be ensured anymore. The regulators VCC1/2 are working properly, however, a thermal shutdown might occur due to high power dissipation. The specified SPI communication speed is ensured; the absolute maximum ratings are not violated, however the device is not intended for continuous operation of $V_S > 28V$. The device operation at high junction temperatures for long periods might reduce the operating life time;
- $V_{CAN} < 4.75V$: The undervoltage bit **VCAN_UV** is set in the SPI register **BUS_STAT** and the transmitter is disabled as long as the UV condition is present;
- $5.25V < V_{CAN} < 6.0V$: CAN transceiver is still functional. However, the communication might fail due to out-of-spec operation;
- $V_{POR,f} < V_S < 5.5V$: Device is still functional; the specified electrical characteristics might not be ensured anymore:
 - The voltage regulators will enter the linear ($R_{DS,on}$) operation mode ,
 - A VCC1_UV reset could be triggered depending on the Vrtx settings,
 - GPIO behavior depends on the respective configuration:
 - HS/LS switches remain switched On as long as the control voltage is sufficient.
 - An unwanted overcurrent shutdown may occur.
 - OC shutdown bit set and the respective HS/LS switch will turn Off;
 - FO output remains On if it was enabled before $V_S > 5.5V$,
 - The specified SPI communication speed is ensured.

General Product Characteristics

4.3 Thermal Resistance

Table 3 Thermal Resistance¹⁾

Parameter	Symbol	Values			Unit	Note or Test Condition	Number
		Min.	Typ.	Max.			
Junction to Soldering Point	$R_{th(JSP)}$	–	14	–	K/W	Exposed Pad	P_4.3.1
Junction to Ambient	$R_{th(JA)}$	–	35	–	K/W	²⁾	P_4.3.2

1) Not subject to production test, specified by design.

2) Specified $R_{th(JA)}$ value is according to Jedec JESD51-2,-5,-7 at natural convection on FR4 2s2p board for a power dissipation of 1.5W; the product (chip+package) was simulated on a 76.2x114.3x1.5mm³ with 2 inner copper layers (2 x 70µm Cu, 2 x 35µm C); where applicable a thermal via array under the exposed pad contacted the first inner copper layer and 300mm² cooling areas on the top layer and bottom layers (70µm).

General Product Characteristics

4.4 Current Consumption

Table 4 Current Consumption

Current consumption values are specified at $T_j = 25^\circ\text{C}$, $V_S = 13.5\text{ V}$, all outputs open (unless otherwise specified)

Parameter	Symbol	Values			Unit	Note or Test Condition	Number
		Min.	Typ.	Max.			
SBC Normal Mode							
Normal Mode current consumption	I_{Normal}	–	3.5	6.5	mA	$V_S = 5.5\text{ V to }28\text{ V}$; $T_j = -40^\circ\text{C to }+150^\circ\text{C}$; VCC2, CAN = Off	P_4.4.1
SBC Stop Mode							
Stop Mode current consumption	$I_{\text{Stop}_{1,25}}$	–	44	55	μA	¹⁾ VCC2 & CAN = Off, Cyclic Wake/Sense & Watchdog = Off; no load on VCC1; $I_{\text{PEAK_TH}} = '0'$	P_4.4.2
Stop Mode current consumption	$I_{\text{Stop}_{1,85}}$	–	50	72	μA	¹⁾²⁾ $T_j = 85^\circ\text{C}$; VCC2 & CAN = Off; Cyclic Wake/Sense & Watchdog = Off; no load on VCC1; $I_{\text{PEAK_TH}} = '0'$	P_4.4.3
Stop Mode current consumption (high active peak threshold)	$I_{\text{Stop}_{2,25}}$	–	65	72	μA	¹⁾ VCC2 & CAN Cyclic Wake/Sense & Watchdog = Off; no load on VCC1; $I_{\text{PEAK_TH}} = '1'$	P_4.4.4
Stop Mode current consumption (high active peak threshold)	$I_{\text{Stop}_{2,85}}$	–	70	92	μA	¹⁾²⁾ $T_j = 85^\circ\text{C}$; VCC2 & CAN Cyclic Wake/Sense & Watchdog = Off; no load on VCC1; $I_{\text{PEAK_TH}} = '1'$	P_4.4.5
SBC Sleep Mode							
Sleep Mode current consumption	$I_{\text{Sleep}_{25}}$	–	15	25	μA	VCC2 & CAN = Off; Cyclic Wake/Sense = Off	P_4.4.6
Sleep Mode current consumption	$I_{\text{Sleep}_{85}}$	–	25	35	μA	²⁾ $T_j = 85^\circ\text{C}$; VCC2 & CAN = Off; Cyclic Wake/Sense = Off	P_4.4.7

General Product Characteristics

Table 4 Current Consumption (cont'd)

Current consumption values are specified at $T_j = 25^\circ\text{C}$, $V_S = 13.5\text{ V}$, all outputs open (unless otherwise specified)

Parameter	Symbol	Values			Unit	Note or Test Condition	Number
		Min.	Typ.	Max.			
Feature Incremental Current Consumption							
Current consumption for CAN module, recessive state	$I_{\text{CAN,rec}}$	–	2	3	mA	²⁾ SBC Normal/Stop Mode; CAN Normal Mode; VCC2 connected to VCAN; VTXDCAN = VCC2; no RL on CAN	P_4.4.8
Current consumption for CAN module, dominant state	$I_{\text{CAN,dom}}$	–	3	5	mA	²⁾ SBC Normal/Stop Mode; CAN Normal Mode; VCC1 connected to VCAN; VTXDCAN = GND; no RL on CAN	P_4.4.9
Current consumption for CAN module, Receive Only Mode	$I_{\text{CAN,RcvOnly}}$	–	0.9	1.2	mA	²⁾ SBC Normal/Stop Mode; CAN Receive Only Mode; VCC1 connected to VCAN; VTXDCAN = VCC1; no RL on CAN	P_4.4.10
Current consumption for WK, GPIO wake capability (all wake inputs)	$I_{\text{Wake,WK,25}}$	–	0.2	2	μA	³⁾⁴⁾⁵⁾ SBC Sleep Mode; WK wake capable; no activity on WK pin; CAN = Off; VCC2 = Off	P_4.4.13
Current consumption for WK, GPIO wake capability (all wake inputs)	$I_{\text{Wake,WK,85}}$	–	0.5	3	μA	²⁾³⁾⁴⁾⁵⁾ SBC Sleep Mode; $T_j = 85^\circ\text{C}$; WK wake capable; no activity on WK pin; CAN = Off; VCC2 = Off	P_4.4.14
Current consumption for CAN wake capability	$I_{\text{Wake,CAN,25}}$	–	4.5	6	μA	³⁾ SBC Sleep Mode; CAN Wake Capable; WK = Off; VCC2 = Off;	P_4.4.15
Current consumption for CAN wake capability	$I_{\text{Wake,CAN,85}}$	–	5.5	7	μA	²⁾³⁾ SBC Sleep Mode; $T_j = 85^\circ\text{C}$; CAN Wake Capable; WK = Off; VCC2 = Off;	P_4.4.16
VCC2 Normal Mode current consumption	$I_{\text{Normal,VCC2}}$	–	2.5	3.5	mA	$V_S = 5.5\text{ V to }28\text{ V}$; $T_j = -40^\circ\text{C to }+150^\circ\text{C}$; VCC2 = On (no load)	P_4.4.17
Current consumption for VCC2 in SBC Sleep Mode	$I_{\text{Sleep,VCC2,25}}$	–	25	35	μA	¹⁾³⁾ SBC Sleep Mode; VCC2 = On (no load); CAN, WK = Off	P_4.4.18

General Product Characteristics

Table 4 Current Consumption (cont'd)

Current consumption values are specified at $T_j = 25^\circ\text{C}$, $V_S = 13.5\text{V}$, all outputs open (unless otherwise specified)

Parameter	Symbol	Values			Unit	Note or Test Condition	Number
		Min.	Typ.	Max.			
Current consumption for VCC2 in SBC Sleep Mode	$I_{\text{Sleep,VCC2,85}}$	–	30	40	μA	¹⁾²⁾³⁾ SBC Sleep Mode; $T_j = 85^\circ\text{C}$; VCC2 = On (no load); CAN, WK = Off	P_4.4.19
Current consumption for GPIO if configured as low-side / high-side in SBC Stop Mode	$I_{\text{Stop,GPIO,25}}$	–	400	550	μA	²⁾³⁾ SBC Stop Mode; GPIO configured as HS or LS with 100% duty cycle (no load); CAN, WK = Off	P_4.4.20
Current consumption for GPIO if configured as low-side / high-side in SBC Stop Mode	$I_{\text{Stop,GPIO,85}}$	–	450	600	μA	²⁾³⁾ SBC Stop Mode; $T_j = 85^\circ\text{C}$; GPIO configured as HS or LS with 100% duty cycle (no load); CAN, WK = Off	P_4.4.21
Current consumption for Cyclic Sense function	$I_{\text{Stop,CS25}}$	–	20	26	μA	³⁾⁶⁾⁷⁾ SBC Stop Mode; WD = Off;	P_4.4.22
Current consumption for Cyclic Sense function	$I_{\text{Stop,CS85}}$	–	24	35	μA	²⁾³⁾⁶⁾⁷⁾ SBC Stop Mode; $T_j = 85^\circ\text{C}$; WD = Off;	P_4.4.23
Current consumption for watchdog active in Stop Mode	$I_{\text{Stop,WD25}}$	–	20	26	μA	²⁾ SBC Stop Mode; Watchdog running;	P_4.4.24
Current consumption for watchdog active in Stop Mode	$I_{\text{Stop,WD85}}$	–	24	35	μA	²⁾ SBC Stop Mode; $T_j = 85^\circ\text{C}$; Watchdog running;	P_4.4.25

- 1) If the load current on VCC1 exceeds the configured VCC1 active peak threshold $I_{\text{VCC1,peak1,r}}$ or $I_{\text{VCC1,peak2,r}}$, the current consumption will increase by typ. 2.9mA to ensure optimum dynamic load behavior. Same applies to VCC2. See also [Chapter 6](#), [Chapter 7](#).
- 2) Not subject to production test, specified by design.
- 3) Current consumption adders of the features defined for SBC Stop Mode also apply for SBC Sleep Mode and vice versa. The wake input signals are stable (i.e. not toggling), Cyclic Wake/Sense & watchdog are Off (unless otherwise specified).
- 4) No pull-up or pull-down configuration selected.
- 5) The specified WK current consumption adder for wake capability applies regardless of how many WK inputs are activated, i.e GPIO configured as wake input.

General Product Characteristics

- 6) GPIO configured as HS used for Cyclic Sense, Timer with 20ms period, 0.1ms on-time, no load on GPIO.

In general the current consumption adder for Cyclic Sense in SBC Stop Mode can be calculated with below equation (no load on FO/GPIO):

$$I_{\text{Stop,CS_typ}} = 18\mu\text{A} + (I_{\text{Stop,GPIO,25}} \times t_{\text{on}}/T_{\text{Per}})$$

where 18uA is the base current consumption of the digital Cyclic Sense / wake-up functionality;

- 7) Also applies to Cyclic Wake but without the contribution of the HS biasing

Notes

1. *There is no additional current consumption in SBC Normal Mode due to PWM generators or Timers.*
2. *To ensure the device functionality down to $V_{\text{por},f}$ the quiescent current will increase gradually by ~35 uA for $V_S < 9\text{ V}$ in SBC Stop Mode and Sleep Mode..*

5 System Features

This chapter describes the system features and behavior of the TLE9461ES:

- State machine
- Device configuration
- SBC mode control
- State of supplies and peripherals
- System functions such as Cyclic Sense or Cyclic Wake
- Charge pump output for reverse polarity protection and Kl. 30 load switching
- High-voltage measurement interface

The System Basis Chip (SBC) offers six operating modes:

- SBC Init Mode: Power-up of the device (initial and after a soft reset),
- SBC Normal Mode: The main operating mode of the device,
- SBC Stop Mode: The first-level power saving mode (the main voltage regulator VCC1 remains enabled),
- SBC Sleep Mode: The second-level power saving mode (VCC1 is disabled),
- SBC Restart Mode: An intermediate mode after a wake-up event from SBC Sleep or Fail-Safe Mode or after a failure (e.g. WD failure, VCC1 under voltage reset) to bring the microcontroller into a defined state via a reset. Once the failure condition is not present anymore the device will automatically change to SBC Normal Mode after a delay time (t_{RD1} or t_{RD2}).
- SBC Fail-Safe Mode: A safe-state mode after critical failures (e.g. WD failure, VCC1 under voltage reset) to bring the system into a safe state and to ensure a proper restart of the system later on. VCC1 is disabled. It is a permanent state until either a wake-up event (via CAN, WK/VSENSE or GPIO configured as wake-up) occurs or the over temperature condition is not present anymore.

A special mode, called SBC Development Mode, is available during software development or debugging of the system. All above mentioned operating modes can be accessed in this mode. However, the watchdog counter is stopped and does not need to be triggered. In addition, CAN is set to normal mode and VCC2 is On. This mode can be accessed by connecting the TEST pin to VCC1 during SBC Init Mode.

The device can be configured via hardware to determine the device behavior after a watchdog trigger failure. See [Chapter 5.1.1](#) for further information.

The System Basis Chip is controlled via a 16-bit SPI interface. A detailed description can be found in [Chapter 13](#). The device configuration as well as the diagnosis is handled via the SPI. The SPI mapping of the TLE9461ES is compatible to other devices of the TLE926x and TLE927x families.

The device offers various supervision features to support functional safety requirements. Please see [Chapter 12](#) for more information.

System Features

5.1 Block Description of State Machine

The different SBC operating modes are selected via SPI by setting the respective SBC **MODE** bits in the register **M_S_CTRL**. The SBC **MODE** bits are cleared when going through SBC Restart Mode and thus always show the current SBC mode.

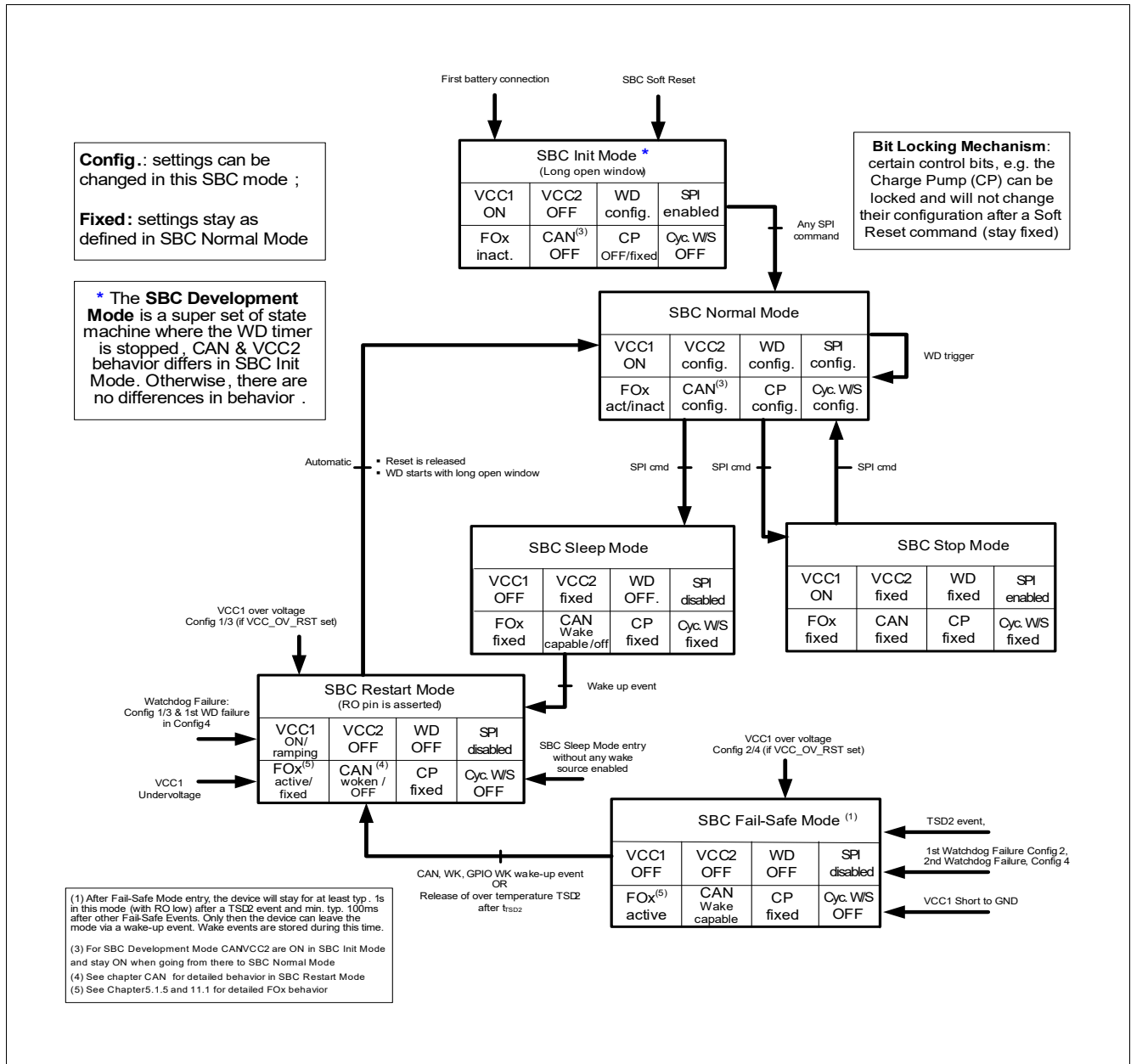

Figure 3 State Diagram showing the SBC Operating Modes

System Features

5.1.1 Device Configuration and SBC Init Mode

The device starts up in SBC Init Mode after crossing the power-on reset threshold $V_{POR,r}$ (see also [Chapter 12.3](#)) and the watchdog starts with a long open window (t_{LW}) after RSTN is released (High level). During this power-on phase the following configurations are stored in the device:

- The device behavior regarding a watchdog trigger failure and a VCC1 over voltage condition is determined by the external circuit on the INTN pin (typ. 47 k Ω pull-up resistor to VCC1, see also below)
- The selection of the normal user mode operation or the SBC Development Mode (watchdog = Off, CAN = On, VCC2 = On for debugging purposes) is set depending on the voltage level of the TEST pin (see also [Chapter 5.1.7](#)).

5.1.1.1 Device Configuration

The configuration selection selects the SBC behavior due to a watchdog trigger failure and VCC1 overvoltage detection. Depending on the requirements of the application, two different configurations can be chosen:

- If the VCC1 output shall be switched Off and the device shall go to SBC Fail-Safe Mode in case of a watchdog failure (1 or 2 fails). To set this configuration (Config 2/4), the INTN pin does not need an external pull-up resistor.
- If VCC1 should not be switched Off (Config 1/3), the INTN pin needs to have an external pull-up resistor connected to VCC1 (see application diagram in [Chapter 14](#)).

Figure 4 shows the timing diagram of the hardware configuration selection. The hardware configuration is defined during SBC Init Mode. The INTN pin is internally pulled Low with a weak pull-down resistor during the reset delay time t_{RD1} , i.e. after VCC1 crosses the reset threshold VRT1 and before the RSTN pin goes High. The INTN pin is monitored during this time (with a continuous filter time of $t_{CFG,F}$) and the configuration (depending on the voltage level at INTN) is stored at the rising edge of RSTN.

*Note: If the **POR** bit is not cleared, then the internal pull-down resistor at INTN is reactivated every time RSTN is pulled Low the configuration is updated at the rising edge of RSTN. Therefore it is recommended to clear the **POR** bit right after initialization. In case there is no stable signal at INTN, then the last filtered value is taken. If no filtered value is taken then the default value '0' is taken as the config select value (= SBC Fail-Safe Mode).*

*Note: During device power up, the SPI status bits **VCC1_WARN**, **VCC1_UV** and **VS_UV** are updated only if RSTN is released after the reset delay time.*

System Features

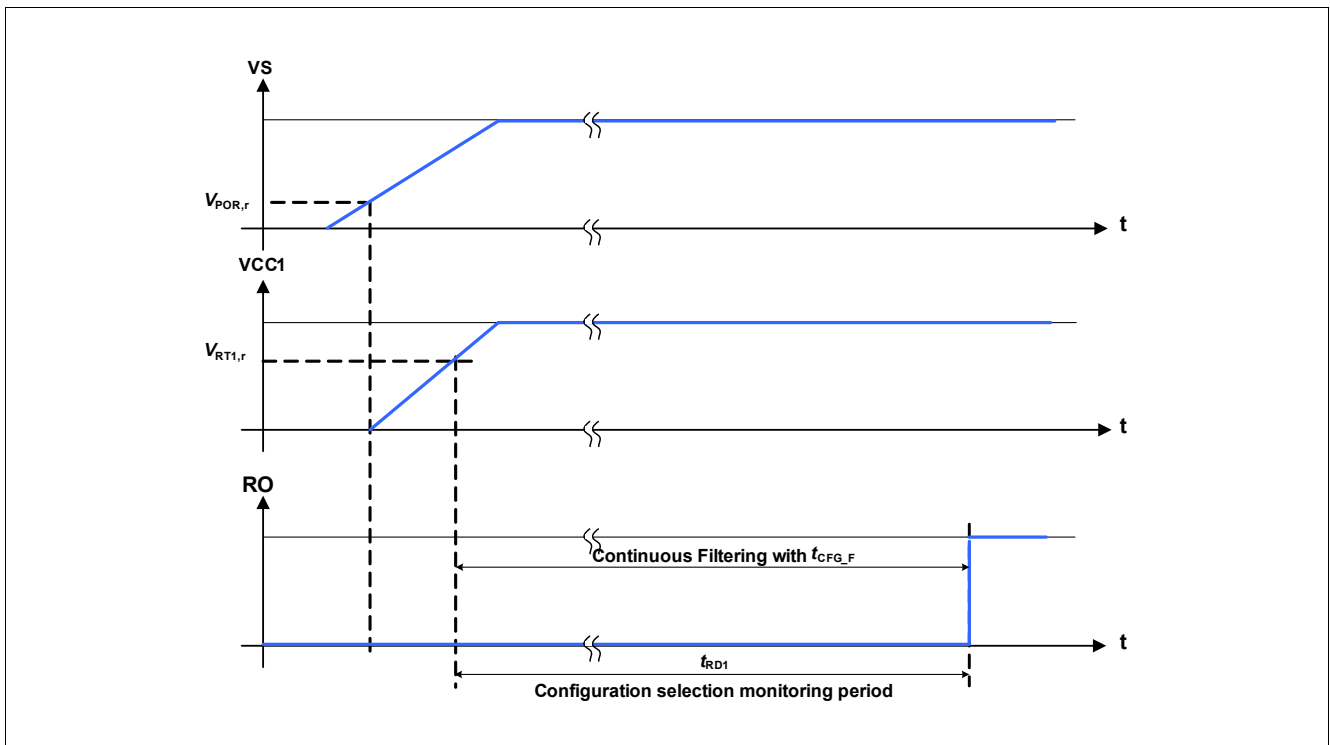

Figure 4 Hardware Configuration Selection Timing Diagram

There are four different device configurations ([Table 5](#)) available defining the watchdog failure and the VCC1 over voltage behavior. The configurations can be selected via the external connection on the INTN pin and the SPI bit **CFG1** in the **HW_CTRL_0** register (see also [Chapter 13.4](#)):

- **CFG0_STATE** = '1': Config 1 and Config 3:
 - A watchdog trigger failure leads to SBC Restart Mode and depending on **CFG1** the Fail Output (FO) is activated after the 1st (Config 1) or 2nd (Config 3) watchdog trigger failure;
 - A VCC1 over voltage detection leads to SBC Restart Mode if **VCC1_OV_RST** is set. **VCC1_OV** is set and the Fail Output is activated;
- **CFG0_STATE** = '0': Config 2 and Config 4:
 - A watchdog trigger failure leads to SBC Fail-Safe Mode and depending on **CFG1** the Fail Output (FO) is activated after the 1st (Config 2) or 2nd (Config 4) watchdog trigger failure. The first watchdog trigger failure in Config 4 leads to SBC Restart Mode;
 - A VCC1 over voltage detection leads to SBC Fail-Safe Mode if **VCC1_OV_RST** is set. **VCC1_OV** is set and the Fail Output is activated;

The respective device configuration can be identified by reading the SPI bit **CFG1** in the **HW_CTRL_0** register and the **CFG0_STATE** bit in the **WK_LVL_STAT** register.

[Table 5](#) shows the configurations and the device behavior in case of a watchdog trigger failure:

System Features

Table 5 Watchdog Trigger Failure Configuration

Config	INTN Pin (CFG0_STATE)	SPI Bit CFG1	Event	FO Activation	SBC Mode Entry
1	External pull-up	1	1 x Watchdog Failure	after 1st WD Failure	SBC Restart Mode
2	No ext. pull-up	1	1 x Watchdog Failure	after 1st WD Failure	SBC Fail-Safe Mode
3	External pull-up	0	1 & 2 x Watchdog Failure	after 2nd WD Failure	SBC Restart Mode
4	No ext. pull-up	0	2 x Watchdog Failure	after 2nd WD Failure	SBC Fail-Safe Mode ¹⁾

1) SBC Restart Mode is entered after the 1. watchdog failure. The 2nd watchdog failure leads to SBC Fail-Safe Mode

Table 6 shows the configurations and the device behavior in case of a VCC1 over voltage detection when **VCC1_OV_RST** is set:

Table 6 Device Behavior in Case of VCC1 Over Voltage Detection

Config	INTN Pin (CFG0_STATE)	CFG1 Bit	VCC1_O V_RST	Event	VCC1_OV	FO Activation	SBC Mode Entry
1-4	any value	x	0	1 x VCC1 OV	1	no FO activation	unchanged
1	External pull-up	1	1	1 x VCC1 OV	1	after 1st VCC1 OV	SBC Restart Mode
2	No ext. pull-up	1	1	1 x VCC1 OV	1	after 1st VCC1 OV	SBC Fail-Safe Mode
3	External pull-up	0	1	1 x VCC1 OV	1	after 1st VCC1 OV	SBC Restart Mode
4	No ext. pull-up	0	1	1 x VCC1 OV	1	after 1st VCC1 OV	SBC Fail-Safe Mode

The respective configuration is stored for all conditions and can only be changed in SBC Init Mode, when RSTN is 'Low' or by powering down the device ($V_S < V_{POR,f}$) assuming the bit **POR** is cleared right after the device power up (see also not on [Page 20](#)).

System Features

5.1.1.2 SBC Init Mode

In SBC Init Mode, the device waits for the microcontroller to finish its startup and initialization sequence.

The SBC starts with a long open watchdog window (see also [Chapter 12.2](#)).

All diagnosis functions which are enabled by default at device power-up are active.

While in SBC Init Mode any valid SPI command (from the SPI protocol, i.e. 16-bit word) sets the device to SBC Normal Mode, i.e. any register can be written, cleared and read. During the long open window the watchdog has to be triggered (i.e. thereby the watchdog is automatically configured).

A missing watchdog trigger during the long open window will cause a watchdog failure and the device will enter SBC Restart Mode.

Wake-up events are ignored during SBC Init Mode.

A SBC Soft Reset command (**MODE** = '11') sets the SBC back into SBC Init Mode and the SPI registers are changed to their respective Soft Reset values. In case one or both lock bits are set (**CFG_LOCK_0** or **CFG_LOCK_1**) the locked bits keep their previous values and stay unchanged.

Note: Any SPI command sets the SBC to SBC Normal Mode even if it is an illegal SPI command (see [Chapter 13.2](#)).

Note: For a safe start-up, it is recommended to use the first SPI command to trigger and to configure the watchdog (see [Chapter 12.2](#)).

Note: At power up, the SPI bit **VCC1_UV** is not set nor is the FO triggered as long as VCC1 is below the $V_{RT,x}$ threshold and VS is below the $V_{s,uv}$ threshold. The RSTN pin is kept Low as long as VCC1 is below the selected $V_{RT,x}$ threshold and the reset delay time is not expired. After the first threshold crossing ($VCC1 > V_{rt1,r}$) and the RSTN transition from Low to High, all subsequent undervoltage events lead to SBC Restart Mode.

Note: The bit **VS_UV** is updated only in SBC INIT Mode once RSTN resumes a high level.

System Features

5.1.2 SBC Normal Mode

The SBC Normal Mode is the standard operating mode for the SBC. All remaining configurations must be done in SBC Normal Mode before entering a low-power mode (see also [Chapter 5.1.6](#)). A wake-up event on CAN, WK/VSENSE, FO/GPIO configured as wake input, the Timer will create an interrupt on pin INTN - however, no change of the SBC mode will occur. The configuration options are listed below:

- VCC1 is always active
- VCC2 can be switched On or Off (default = Off)
- CAN is configurable (it is Off coming from SBC Init Mode; Off or Wake Capable coming from SBC Restart Mode, see also [Chapter 5.1.5](#))
- WK/VSENSE pin shows the input level and can be selected to be wake capable (interrupt), the alternative measurement function with the voltage output at FO/GPIO can be activated by setting [WK_MEAS](#)
- Cyclic Sense can be configured with the HS function of the GPIO ([GPIO](#) = '011'), WK/VSENSE input and Timer
- Cyclic Wake can be configured using the timer
- Watchdog period is configurable
- The Charge Pump Output can be switched On or Off (default = Off)
- The FO/GPIO output is inactive by default. Coming from SBC Restart Mode and configured as FO it can be active (due to a failure event, e.g. watchdog trigger failure, VCC1 short circuit, etc.) or inactive (no failure occurred)
- GPIO is configurable and is controlled by PWM; GPIO is Off coming from SBC Restart Mode

Certain SPI control bits with the bit type 'rwl' can be protected against unintentional modification by setting the [CFG_LOCK_1](#) bit in the register [HW_CTRL_2](#). The locking mechanism stays activated until the device is powered down ($V_S < V_{POR,f}$). The charge pump and GPIO configuration can also be locked by setting the [CFG_LOCK_0](#) bit in the register [HW_CTRL_1](#). The lock can be reset in SBC Normal Mode.

In SBC Normal Mode, the FO output can be tested within the system (i.e. to verify whether setting the FO/GPIO pin to Low creates the intended behavior). The FO output can be enabled and then disabled again by the microcontroller setting or resetting the [FO_ON](#) SPI bit. This feature is only intended for testing purposes.

System Features

5.1.3 SBC Stop Mode

The SBC Stop Mode is the first level technique to reduce the overall current consumption by setting the voltage regulators VCC1, VCC2 into a low-power mode. In this mode VCC1 is still active, supplying the microcontroller, which can enter a power-down mode. The VCC2 supply can be configured to stay enabled and CAN to stay in Normal Mode. All settings have to be done before entering SBC Stop Mode. In SBC Stop Mode all SPI WRITE commands are ignored and the **SPI_FAIL** bit is set. Exceptions are changing to SBC Normal Mode, triggering a SBC Soft Reset, refreshing the watchdog as well as reading and clearing the SPI status registers. A wake-up event on CAN, WK/VSENSE, FO/GPIO (if configured as wake input) and Timer create an interrupt on pin INTN - however, the SBC mode remains unchanged. The configuration options are listed below:

- VCC1 is always On
- VCC2 is fixed as configured in SBC Normal Mode
- CAN mode is fixed as configured in SBC Normal Mode
- WK/VSENSE pin is fixed as configured in SBC Normal Mode
- Cyclic Sense is fixed as configured in SBC Normal Mode
- Cyclic Wake is fixed as configured in SBC Normal Mode
- Watchdog is fixed as configured in SBC Normal Mode
- SBC Soft Reset can be triggered
- The Charge Pump state is fixed as configured in SBC Normal Mode
- FO output works as configured in SBC Normal Mode unless it is changed by the software (i.e. by clearing the **FAILURE** bit and triggering the watchdog properly)
- GPIO is fixed as configured in SBC Normal Mode

If not all wake source signalization flags from **WK_STAT_0** and **WK_STAT_1** are cleared before entering SBC Stop Mode, then an interrupt is triggered on the pin INTN.

Note: If outputs are kept enabled during SBC Stop Mode, e.g. HS of GPIO, then the SBC current consumption increases respectively (see [Chapter 4.4](#)).

*Note: It is not possible to switch directly from SBC Stop Mode to SBC Sleep Mode. Doing so sets the **SPI_FAIL** flag and SBC into Restart Mode is entered.*

*Note: When WK/VSENSE and FO/GPIO are configured for the alternative measurement function (**WK_MEAS** = 1) the pins cannot be selected as wake input sources.*

System Features

5.1.4 SBC Sleep Mode

The SBC Sleep Mode is the second level technique to reduce the overall current consumption to a minimum needed to react on wake-up events or for the SBC to perform autonomous actions (e.g. Cyclic Sense). In this mode, VCC1 is Off, not supplying the microcontroller anymore. The VCC2 supply can be configured to stay enabled. The settings have to be done before entering SBC Sleep Mode. A wake-up event on CAN, WK/VSENSE, FO/GPIO (if configured as wake input) and the internal Timer brings the device via the SBC Restart Mode subsequently to SBC Normal Mode again and signals the wake source.

The configuration options are listed below:

- VCC1 is always Off
- VCC2 is fixed as configured in SBC Normal Mode
- CAN mode changes automatically from On or Receive Only Mode to Wake Capable mode or can be selected to be Off
- WK/VSENSE pin is fixed as configured in SBC Normal Mode
- Cyclic Sense is fixed as configured in SBC Normal Mode
- Cyclic Wake is fixed as configured in SBC Normal Mode, it can be the only activated wake source
- Watchdog is Off
- The Charge Pump state is fixed as configured in SBC Normal Mode
- FO output is fixed as configured in SBC Normal Mode is maintained
- GPIO is fixed as configured in SBC Normal Mode, it can be the only wake source if configured as WK/VSENSE
- RSTN is pulled low
- SPI communication and all digital I/Os are disabled because VCC1 is Off
- The Sleep Mode entry is signalled in the SPI register **DEV_STAT** with the bit **DEV_STAT**

It is not possible to switch Off all wake sources in SBC Sleep Mode. Doing so sets the **SPI_FAIL** flag and the device enters SBC Restart Mode.

In order to enter SBC Sleep Mode successfully, all wake source signalization flags from **WK_STAT_0** and **WK_STAT_1** need to be cleared. A failure to do so results in an immediate wake-up from SBC Sleep Mode by going via SBC Restart to Normal Mode.

All settings must be done before entering SBC Sleep Mode.

Note: If outputs are kept enabled during SBC Sleep Mode, e.g. HS of GPIO, then the SBC current consumption increases respectively (see [Chapter 4.4](#)).

Note: The Cyclic Sense function might not work properly anymore in case of a failure event (e.g. overcurrent, over temperature, reset) because the configured HS of the GPIO and Timer might be disabled.

*Note: When WK/VSENSE and FO/GPIO are configured for the alternative measurement function (**WK_MEAS** = 1) then the pins cannot be selected as wake input sources.*

System Features

5.1.5 SBC Restart Mode

There are multiple reasons to enter the SBC Restart Mode. The main purpose of the SBC Restart Mode is to reset the microcontroller:

- in case of under voltage at VCC1 in SBC Normal and SBC Stop Mode and SBC Init Mode after RSTN has been released,
- in case of over voltage at VCC1 (if the bit **VCC1_OV_RST** is set and if **CFG0_STATE** = '1'),
- due to 1st incorrect Watchdog triggering (only if Config1, Config3 or Config 4 is selected, otherwise SBC Fail-Safe Mode is immediately entered),
- In case of a wake event from SBC Sleep or Fail-Safe Mode or a release of over temperature shutdown (TSD2) out of SBC Fail-Safe Mode (this transition is used to ramp up VCC1 in a defined way).

From SBC Restart Mode, the device enters automatically to SBC Normal Mode. The SBC **MODE** bits are cleared. As shown in **Figure 32** the Reset Output (RSTN) is pulled Low when entering Restart Mode and is released (going High) at the transition to SBC Normal Mode after the reset delay time (t_{RD1}). The watchdog timer starts with a long open window starting from the moment of the rising edge of RSTN. The watchdog period settings in the register **WD_CTRL** are changed to the respective default value '100'.

Leaving the SBC Restart Mode does not result in changing / deactivating the Fail Output.

The behavior of the blocks is listed below:

- FO (if configured as FO) is activated in case of a 1st watchdog trigger failure (Config1) or a 2nd watchdog failure (Config3) or in case of VCC1 over voltage detection (if **VCC1_OV_RST** is set)
- VCC1 stays On or is ramping up (coming from SBC Sleep or Fail-Safe Mode)
- VCC2 is disabled if it was activated before
- CAN is “woken” due to a wake-up event or Off depending on the previous SBC and transceiver mode (see also **Chapter 8**). It is Wake Capable when it was in CAN Normal-, Receive Only or Wake Capable mode before SBC Restart Mode
- GPIO behavior: switched Off if configured as LS- or HS-switch, see also **Chapter 11.1.2**
- RSTN is internally pulled Low during SBC Restart Mode
- SPI communication is ignored by the SBC, i.e. it is not interpreted
- The SBC Restart Mode entry is signalled in the SPI register **DEV_STAT** with the bits **DEV_STAT**

Table 7 Reasons for Restart - State of SPI Status Bits (after Return to SBC Normal Mode)

Prev. SBC Mode	Event	DEV_STAT	WD_FAIL	VCC1_UV	VCC1_OV	VCC1_SC
Normal	1x Watchdog Failure	01	01	x	x	x
Normal	2x Watchdog Failure	01	10	x	x	x
Normal	VCC1 under voltage reset	01	xx	1	x	x
Normal	VCC1 over voltage reset	01	xx	x	1	x
Stop	1x Watchdog Failure	01	01	x	x	x
Stop	2x Watchdog Failure	01	10	x	x	x
Stop	VCC1 under voltage reset	01	xx	1	x	x
Stop	VCC1 over voltage reset	01	xx	x	1	x
Sleep	Wake-up event	10	xx	x	x	x
Fail-Safe	Wake-up event	01	see “Reasons for Fail Safe, Table 8 ”			

System Features

Note: An over voltage event at VCC1 leads to SBC Restart Mode only if the bit `VCC1_OV_RST` is set and if `CFG0_STATE = '1'` (Config 1/3).

Note: The content of the `WD_FAIL` bits depends on the device configuration, e.g. 1 or 2 watchdog failures.

5.1.6 SBC Fail-Safe Mode

The purpose of this mode is to bring the system in a safe status after a failure condition by turning Off the VCC1 supply and powering Off the microcontroller. After a wake-up event the system restarts again.

The Fail-Safe Mode is automatically entered after following events:

- SBC thermal shutdown (TSD2) (see also [Chapter 12.8.3](#)),
- over voltage on VCC1 if the bit `VCC1_OV_RST` is set and if `CFG0_STATE = '0'`,
- 1st incorrect watchdog trigger in Config2 (`CFG1 = 1`) and after a 2nd incorrect watchdog trigger in Config4 (`CFG1 = 0`) (see also [Chapter 5.1.1](#)),
- VCC1 is shorted to GND (see also [Chapter 12.6](#)),

In this case, the default wake sources CAN, WK/VSENSE and FO/GPIO (if configured as wake input - see also registers `BUS_CTRL_0`, `WK_CTRL_1` and `GPIO_CTRL`) are activated, the previous wake-up events are cleared in the register `WK_STAT_0` and `WK_STAT_1`, and both voltage regulators and the GPIO - if configured as HS or LS - are switched Off.

The SBC Fail-Safe Mode is entered regardless of the FO/GPIO pin configuration. If WK/VSENSE and FO/GPIO are configured for the alternative measurement function (`WK_MEAS = 1`) then these pins keep their configuration for the measurement function when SBC Fail-Safe Mode is entered, i.e. they are not automatically activated as wake sources.

The SBC Fail-Safe Mode is maintained until a wake-up event on the default wake sources occurs. To avoid any fast toggling behavior a filter time of typ. 100ms ($t_{FS,min}$) is implemented. Wake-up events during this time is stored and automatically lead to SBC Restart Mode after the filter time.

In case of a VCC1 over temperature shutdown (TSD2), the SBC Restart Mode is entered automatically after a filter time of typ. 1s (t_{TSD2}) (without the need of a wake-up event) once the device temperature has fallen below the TSD2 threshold. Please see [Chapter 12.8.3](#) on how to extend the minimum TSD2 waiting time.

Leaving the SBC Fail-Safe Mode does not result in a deactivation of the Fail Output pins.

The following functions are controlled by the C Fail-Safe Mode:

- FO output (if configured as FO) is activated (see also [Chapter 11](#))
- VCC1 is switched Off
- VCC2 is switched Off
- CAN is set to Wake Capable
- GPIO behavior:
 - if configured as HS or LS: it is switched Off
 - if configured as wake input: it is set to wake capable in Static Sense mode
- WK/VSENSE pin is set to wake capable in Static Sense mode (only if `WK_MEAS = 0`)
- Cyclic Sense and Cyclic Wake is disabled
- SPI communication is disabled because VCC1 is Off, RSTN and digital I/O pins are pulled Low
- The Fail-Safe Mode activation is signalled in the SPI register `DEV_STAT` with the bits `FAILURE` and `DEV_STAT`

System Features

Table 8 Reasons for Fail-Safe - State of SPI Status Bits after Return to Normal Mode

Prev. SBC Mode	Failure Event	DEV_STAT	TSD2	WD_FAIL	VCC1_UV	VCC1_OV	VCC1_SC
Normal	1 x Watchdog Failure	01	x	01	x	x	x
Normal	2 x Watchdog Failure	01	x	10	x	x	x
Normal	TSD2	01	1	xx	x	x	x
Normal	VCC1 short to GND	01	x	xx	1	x	1
Normal	VCC1 over voltage	01	x	xx	x	1	x
Stop	1 x Watchdog Failure	01	x	01	x	x	x
Stop	2 x Watchdog Failure	01	x	10	x	x	x
Stop	TSD2	01	1	xx	x	x	x
Stop	VCC1 short to GND	01	x	xx	1	x	1
Stop	VCC1 over voltage	01	x	xx	x	1	x

Note: An over voltage event on VCC1 leads to SBC Fail-Safe Mode only if the bit VCC1_OV_RST is set and if **CFG0_STATE** = '0' (Config 2/4).

Note: The content of the WD_FAIL bits depends on the device configuration, e.g. 1 or 2 watchdog failures.

5.1.7 SBC Development Mode

The SBC Development Mode is used during the development phase of the module. It is especially useful for software development.

Compared to the default SBC user mode operation, this mode is a super set of the state machine. The device starts also in SBC Init Mode and it is possible to use all the SBC Modes and functions with the following differences:

- Watchdog is stopped and does not need to be triggered. Therefore no reset is triggered due to watchdog failure
- SBC Fail-Safe and SBC Restart Mode are not activated by a watchdog trigger failure (but the other reasons to enter these modes are still valid)
- CAN and VCC2 default values in SBC Init Mode and if entering SBC Normal Mode from SBC Init Mode is On (instead of Off)

The SBC Development Mode is entered automatically, if the TEST pin is set High (i.e. connected to VCC1 with (5V level) during SBC Init Mode. The voltage level monitoring is started as soon as $V_S > V_{POR,r}$ and $V_{CC1} > V_{RT1,r}$. The SBC Development Mode is set and maintained, if SBC Init Mode is left by sending any SPI command while TEST is High. The bit **SBC_DEV_LVL** shows the status of the SBC Development Mode.

The Test pin has an integrated pull-down resistor, R_{TEST} (switched On only during SBC Init Mode), to prevent an unintentional SBC Development Mode entry (see also **Figure 5**).

Note: The integrated pull-down resistor is disabled only, if the SBC Development Mode has been entered successfully, i.e. not when the SBC Init Mode is left with an error (watchdog failure, VCC1 undervoltage reset, etc).

During normal user mode, the integrated pull-down resistor is always activated. In this case the TEST pin can be left open or connect to GND

System Features

Note: In case a VCC2 overtemperature event occurs in SBC Init Mode., after SBC Development Mode is entered, VCC2 is shut down.

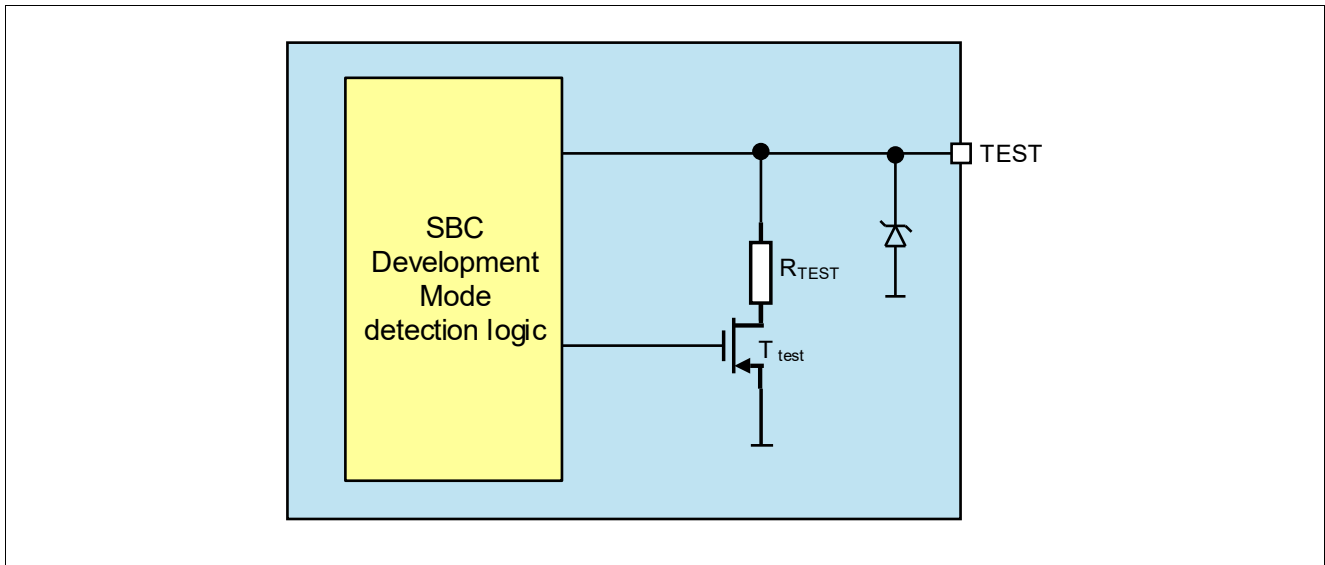

Figure 5 Block Diagram of Pin TEST for SBC Development Mode Detection

In case the pin level toggles with a period faster than t_{TEST} during the monitoring period the SBC Development Mode is not reached .

The SBC remains in this mode for all operating conditions and can only be left by powering down the device ($V_S < V_{POR,f}$).

Note: If the SBC enters SBC Fail-Safe Mode due to VCC1 shorted to GND during the SBC Init Mode, the SBC Development is not entered and can only be activated at the next power-up of the SBC (after the VCC1 short circuit is removed).

Note: The absolute maximum ratings of the pin TEST must be observed. To increase the robustness of this pin during debugging or programming a series resistor between TEST and the connector can be added (see [Figure 47](#)).

System Features

5.1.8 Electrical Characteristics for Pin TEST

Table 9 Electrical Characteristics¹⁾

$V_S = 5.5\text{ V to }28\text{ V}$; $T_j = -40^\circ\text{C to }+150^\circ\text{C}$; SBC Normal Mode; all voltages with respect to ground; positive current defined flowing into pin (unless otherwise specified)

Parameter	Symbol	Values			Unit	Note or Test Condition	Number
		Min.	Typ.	Max.			
Pull-down Resistance at pin TEST	R_{TEST}	7	10	13	k Ω	²⁾ $V_{\text{TEST}} = V_{\text{CC1}}$; SBC Init Mode;	P_5.1.1
TEST Input Filter Time	t_{TEST}	51	64	80	μs	³⁾	P_5.1.2
TEST High Input Voltage Threshold	$V_{\text{TEST,IH}}$	–	–	$0.7 \times V_{\text{CC1}}$	V	²⁾	P_5.1.3
TEST Low Input Voltage Threshold	$V_{\text{TEST,IL}}$	$0.3 \times V_{\text{CC1}}$	–	–	V	²⁾	P_5.1.4
TEST Hysteresis of Input Voltage	$V_{\text{TEST,IHY}}$	$0.08 \times V_{\text{CC1}}$	$0.12 \times V_{\text{CC1}}$	$0.4 \times V_{\text{CC1}}$	V	²⁾	P_5.1.5

1) The external capacitance on the TEST pin must be limited to less than 10nF to ensure proper detection of SBC Development Mode and SBC User Mode operation.

2) Not subject to production test, specified by design.

3) Not subject to production test, tolerance defined by internal oscillator tolerance.

System Features

5.2 Wake Features

The following wake sources are implemented in the device:

- Static Sense: WK/VSENSE input and/or GPIO WK input are permanently active as a wake source, i.e **WK_EN** is set and/or FO/GPIO is enabled as wake input (see [Chapter 9.2.2](#) & [Chapter 11.1.3](#))
- Cyclic Sense: WK/VSENSE input only active during On-time of Cyclic Sense period. Internal timer is activating GPIO HS during On-time for sensing the WK/VSENSE input (see [Chapter 5.2.1](#))
- Cyclic Wake: wake-up is controlled by internal timer, wake inputs are not used for Cyclic Wake (see [Chapter 5.2.2](#))
- CAN wake: Wake-up via CAN message, i.e. CAN wake-up pattern (WUP, see also [Chapter 8](#))

5.2.1 Cyclic Sense

The Cyclic Sense feature is intended to reduce the quiescent current of the device and the application. In the Cyclic Sense configuration, the GPIO (configured as high-side driver) is switched On periodically, controlled by **TIMER_CTRL**. The high-side switch supplies external circuitries e.g. switches and/or resistor arrays, which are connected to the wake input WK (see [Figure 6](#)). Any edge change of the WK/VSENSE input signal during the On-time of the Cyclic Sense period causes a wake-up. Depending on the SBC mode, either the INTN is pulled Low (SBC Normal Mode and Stop Mode) or the SBC is woken enabling the VCC1 (after SBC Sleep Mode).

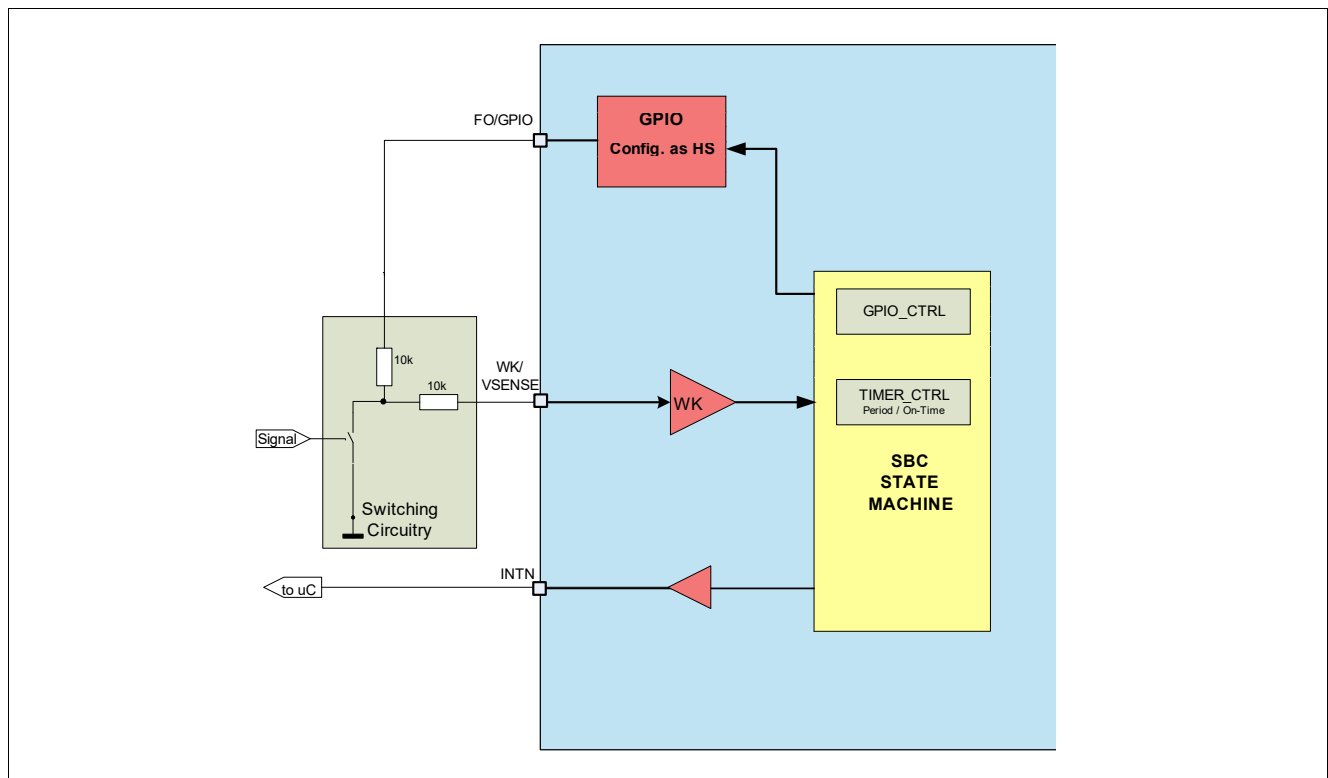

Figure 6 Cyclic Sense Working Principle

System Features

5.2.1.1 Configuration and Operation of Cyclic Sense

The correct sequence to configure the Cyclic Sense is shown in **Figure 7**. All the configurations have to be performed before the On-time is set in the **TIMER_CTRL** registers.

Cyclic Sense (=Timer) starts as soon as the respective On-time has been selected independently from the assignment of the HS and the filter configuration.

The correct configuration sequence is as follows:

- Configuring GPIO as HS with Cyclic Sense functionality
- Enabling WK/VSENSE as wake source
- Selecting the pull-up/down configuration, all configurations are valid for Cyclic Sense, recommended is the automatic pull-up / down selection
- Configuring the timer period and On-time

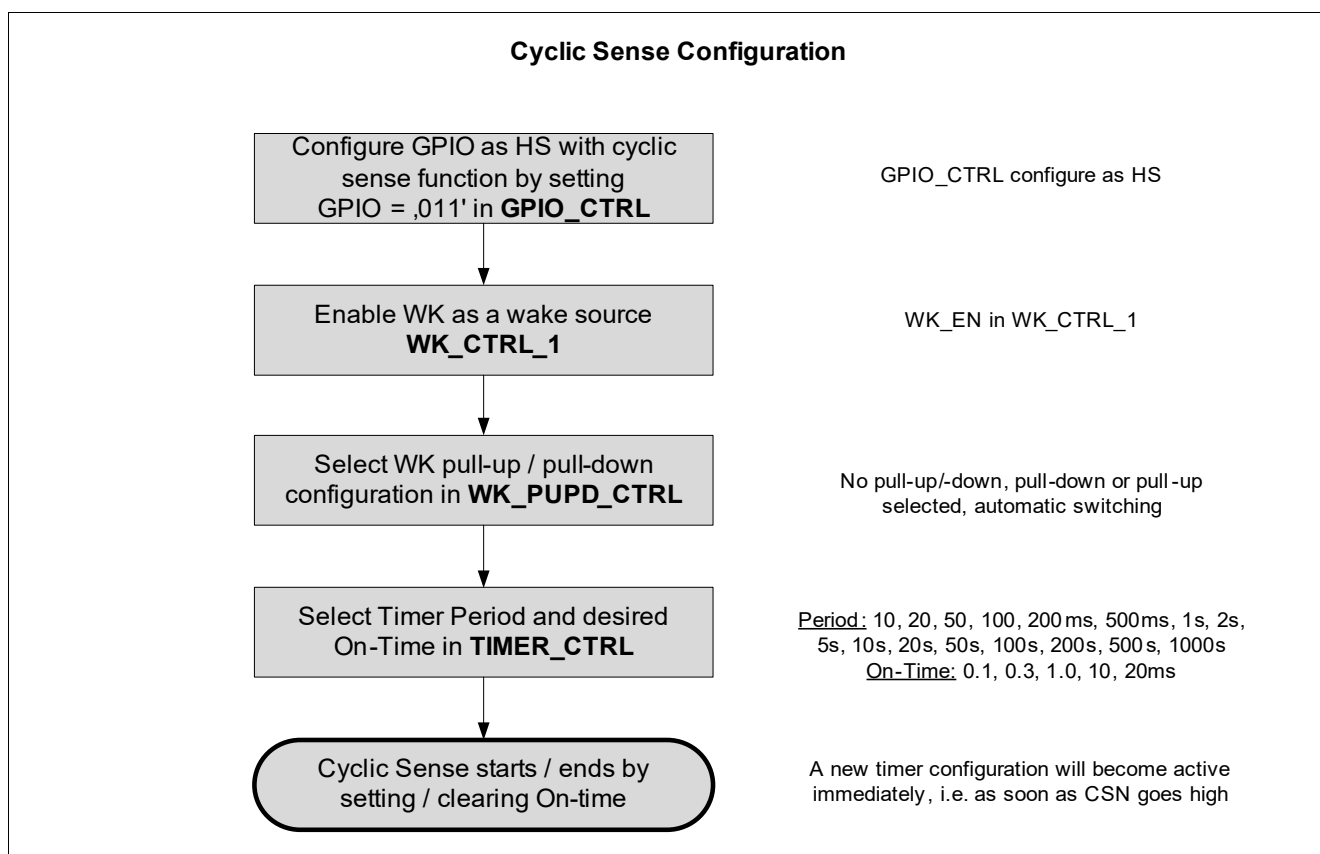

Figure 7 Cyclic Sense: Configuration and Sequence

Note: If the sequence is not ensured the Cyclic Sense function might not work properly, e.g. an interrupt could be missed or an unintentional interrupt could be triggered. However, if Cyclic Sense is the only wake source and configured properly (e.g. Timer not yet set), then SBC Restart Mode is entered immediately because no valid wake source was set.

Note: All configurations of period and On-time can be selected. However, recommended On-times for Cyclic Sense are 0.1ms, 0.3ms and 1ms for quiescent current saving reasons. The SPI_FAIL is set if the On-time is longer than the period.

Note: A learning cycle is started every time when the timer is started via the On-time and GPIO is configured as HS with Cyclic Sense = '011 (i.e. the Cyclic Sense function is enabled).

System Features

The first sample of the WK/VSENSE input value (High or Low) is used as the reference for the next cycle. If a change of the WK/VSENSE input level is detected during the On-time of the second or later cycle then a wake-up from SBC Sleep Mode or an interrupt during SBC Normal or SBC Stop Mode is triggered.

A filter time of 16µs is implemented to avoid a parasitic wake-up due to transients or EMI disturbances. The filter time t_{FWK1} is triggered right at the end of the selected On-time and a wake signal is recognized if:

- there was an input level change (crossing the switching threshold level V_{wkth}) between the current and previous cycle and
- the input level did not change during the filter time

A wake-up event due to Cyclic Sense also sets the bit **WK_WU**.

During Cyclic Sense, **WK_LVL_STAT** is updated only with the sampled voltage levels of the WK/VSENSE pin in SBC Normal or SBC Stop Mode.

*Note: In SBC Stop Mode the respective bits **WK_WU** and **WK_LVL** are only updated if the timer On-time is configured for **TIMER_ON** = '001'.*

The functionality of the sampling and different scenarios are depicted in **Figure 8** to **Figure 10**. The behavior in SBC Stop and SBC Sleep Mode is identical except that in SBC Normal and Stop Mode INTN is triggered to signal a change of WK/VSENSE input level and in SBC Sleep Mode, VCC1 will power-up instead. A wake-up event is triggered regardless if the bit **WK_WU** is already set.

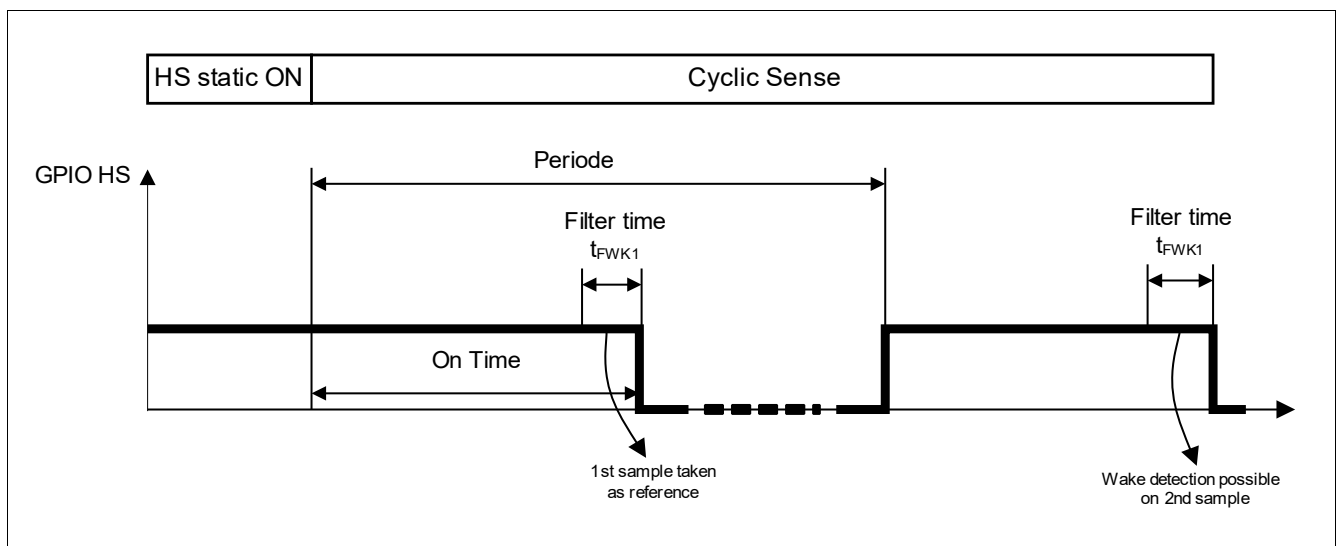

Figure 8 Cyclic Sense Timing

System Features

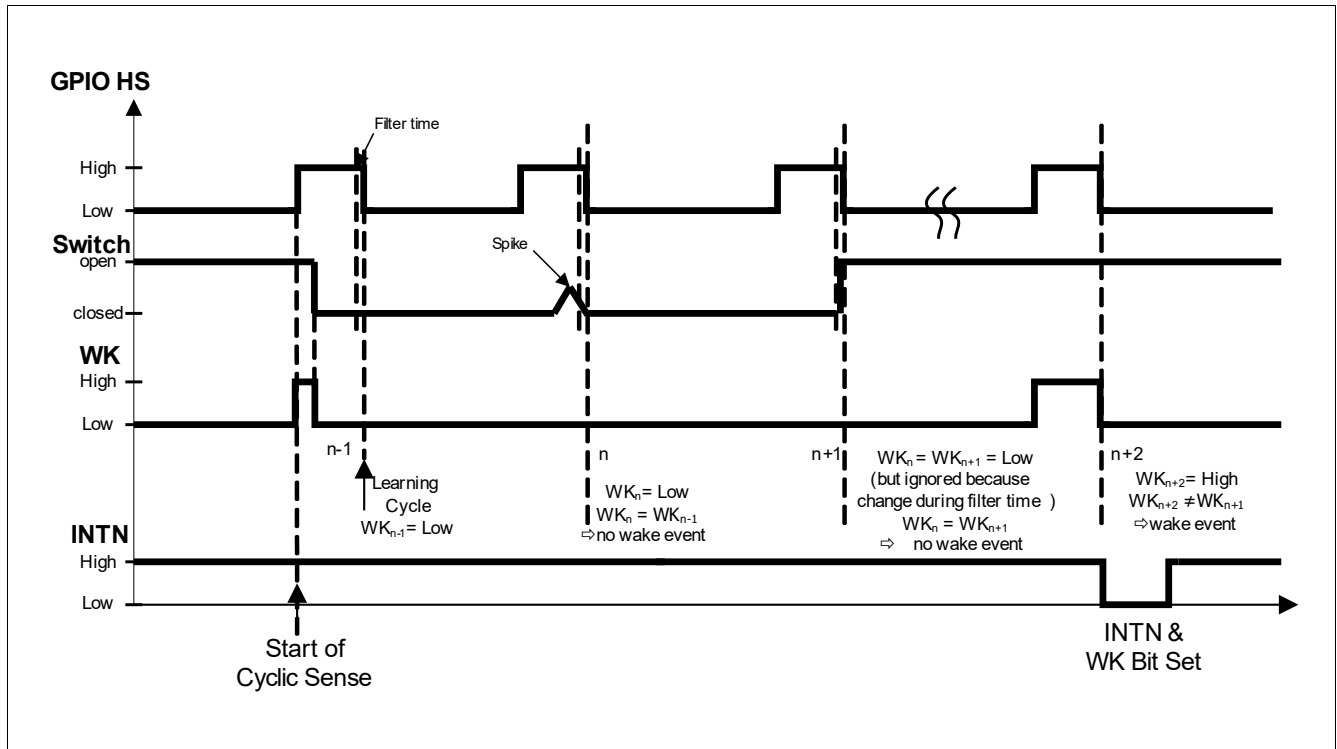

Figure 9 Cyclic Sense Example Timing for SBC Stop Mode, HS starts Low, GND based WK/VSENSE input

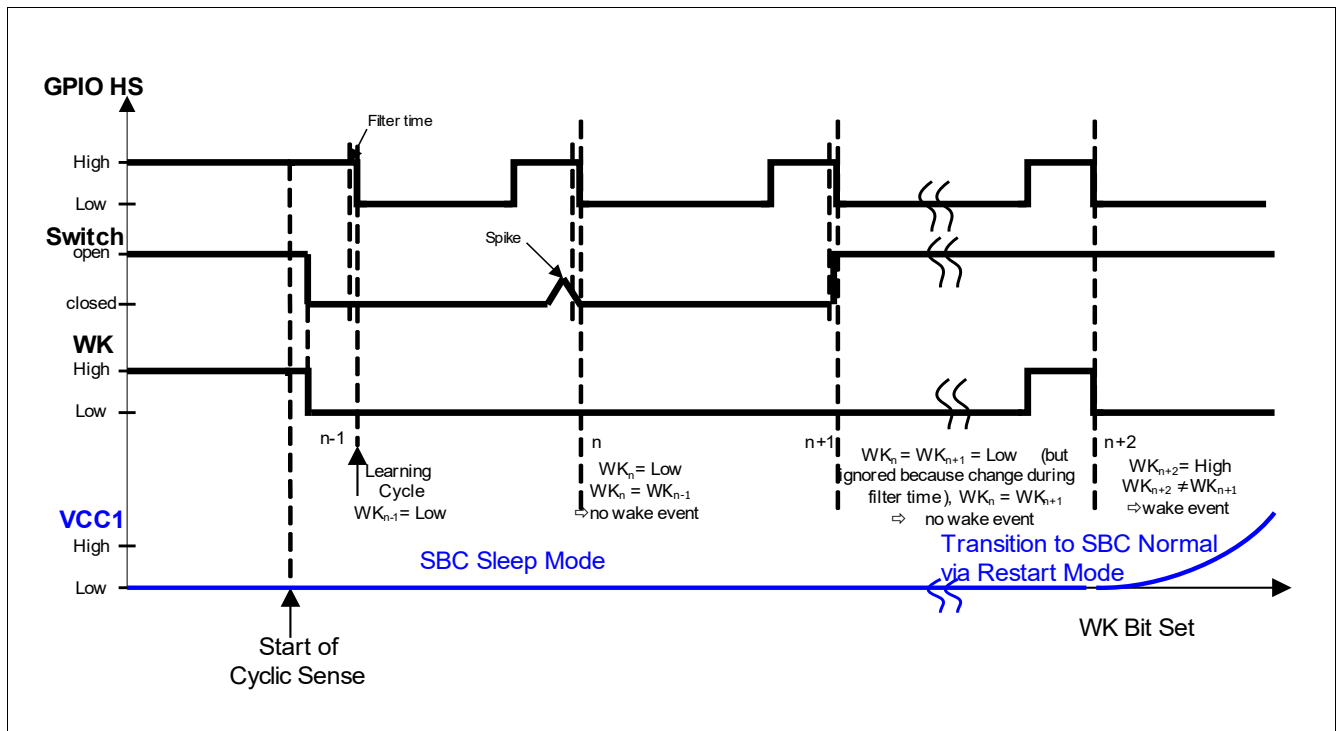

Figure 10 Cyclic Sense Example Timing for SBC Sleep Mode, HS starts with On, GND based WK/VSENSE input

System Features

The Cyclic Sense function is disabled at the following conditions (WK/VSENSE is automatically switched to Static Sense):

- in case SBC Fail-Safe Mode is entered: The HS GPIO switch is disabled and the wake pin is changed to static sensing. An unintended wake-up event could be triggered when the WK/VSENSE input is changed to static sensing.
- In SBC Normal, Stop, or Sleep Mode in case of an overcurrent or overtemperature (TSD2) event: the HS GPIO switch is disabled

Note: The internal timer for Cyclic Sense is not cleared automatically in case the HS switch is turned Off due to above mentioned failures. The timer is only cleared during SBC Restart Mode. This must be considered to avoid a loss of wake-up events, especially before entering SBC Sleep Mode, i.e. the software must ensure that at least another wake source is active or re-enable the GPIO HS again.

5.2.1.2 Cyclic Sense in Low-Power Mode

If Cyclic Sense is intended for use in SBC Stop or SBC Sleep Mode, it is necessary to activate Cyclic Sense in SBC Normal Mode before going to the low-power mode. A wake-up event due to Cyclic Sense sets the bit **WK_WU**. In SBC Stop Mode a wake-up event triggers an interrupt, in SBC Sleep Mode the wake-up event moves the device via SBC Restart Mode to SBC Normal Mode.

Before returning to SBC Sleep Mode, the wake status registers **WK_STAT_0** and **WK_STAT_1** need to be cleared. Trying to go to SBC Sleep Mode with uncleared wake flags leads to a direct wake-up from Sleep Mode by going via Restart Mode to Normal Mode and triggering of RSTN.

The intention of this behavior is to prevent a loss of a wake-up event during the transition.

Note: if an over-current shutdown occurs at the GPIO HS in SBC Sleep Mode, while configured as Cyclic Sense, and Cyclic Sense is the only wake source, then the SBC leaves SBC Sleep Mode immediately because there is no other wake source available .

5.2.2 Cyclic Wake

The Cyclic Wake feature is intended to reduce the quiescent current of the device in the application. The internal timer wakes the load, e.g. the microcontroller, periodically while it is in a low-power mode for the most of the time.

For the Cyclic Wake feature the timer is configured as an internal wake-up source and periodically triggers an interrupt on INTN in SBC Normal and SBC Stop Mode. During SBC Sleep Mode, the timer periodically wakes the device (via SBC Restart to SBC Normal Mode).

The correct sequence to configure the Cyclic Wake is shown in **Figure 11**. The sequence is as follows:

- Enable Timer as a wake-up source in the register **WK_CTRL_0**,
- Configure the period of the Timer. Also an On-time (any value except '000' or '110' or '111') must be selected to start the Cyclic Wake function.

System Features

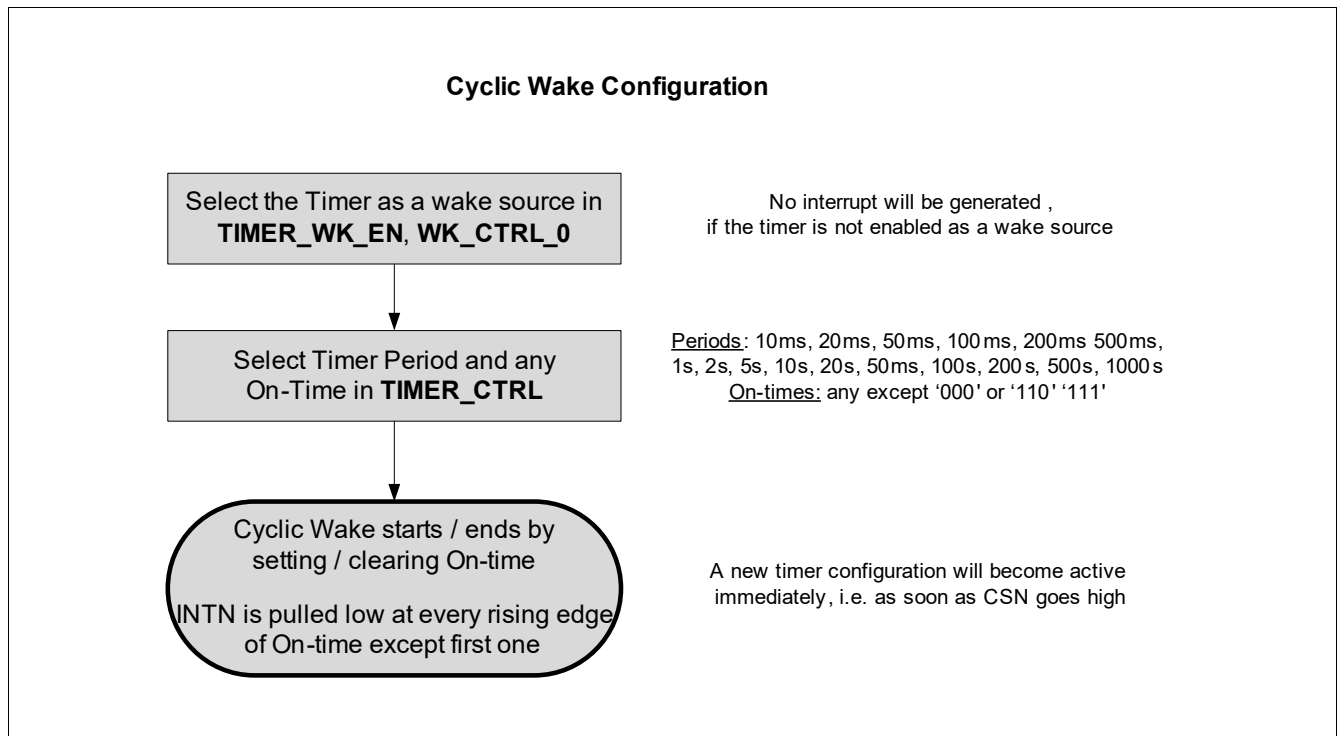

Figure 11 Cyclic Wake: Configuration and Sequence

As in Cyclic Sense, the Cyclic Wake function starts as soon as the On-time is configured. An interrupt is generated for every start of the On-time except for the very first time when the timer is started.

5.2.3 Internal Timer

The integrated timer can be used to control the below features:

- Cyclic Wake, i.e. to wake-up the microcontroller periodically in SBC Normal, Stop and Sleep Mode
- Cyclic Sense, i.e. to perform cyclic sensing using the wake input WK/VSENSE and the GPIO configured as HS by mapping the timer accordingly via the **GPIO_CTRL** register.

Following periods and On-times can be selected via the register **TIMER_CTRL** respectively:

- Period: 10ms, 20ms, 50ms, 100ms, 200ms, 500ms, 1s, 2s, 5s, 10s, 20s, 50s, 100s, 200s, 500s, 1000s
- On-time: 0.1ms / 0.3ms / 1.0ms / 10ms / 20ms / Off at High or Low

Note: It is also possible to activate Cyclic Sense and Cyclic Wake at the same time with the same timer setting

System Features

5.3 Charge Pump Output for Reverse Polarity Protection

A gate-driver (charge-pump output) is integrated in the TLE9461ES to drive external n-channel logic-level MOSFETs on-board to provide Reverse Polarity Protection in the application or to control a KL. 30 switch (see **Figure 12**). The gate voltage is provided at the pin VCP which should be connected as shown in **Chapter 14**. The Charge Pump is able to drive up to 3 n-channel MOSFETs with a typ. Ron of 5mΩ.

A spread spectrum modulation feature is implemented for improved EMC behavior. Enabling and configuring the spread spectrum modulation frequency is achieved via the SPI bits **SS_MOD_FR**.

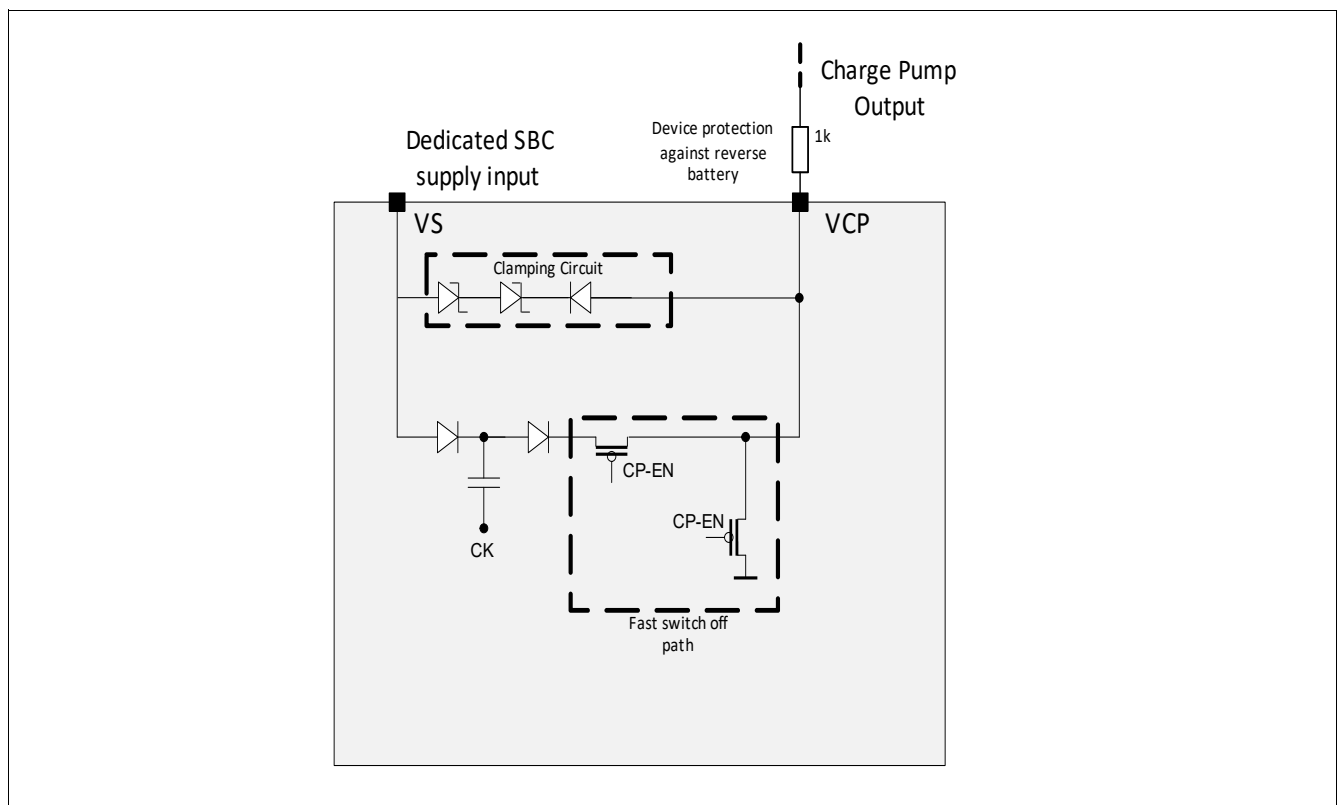

Figure 12 Simplified Charge Pump Block

The charge pump output VCP is disabled in SBC Init Mode and can be configured in SBC Normal Mode via the SPI bit **CP_EN**. To prevent an unintentional modification of the charge pump state the bit **CP_EN** can be locked by setting the bit **CFG_LOCK_0**. In case the charge pump output must be disabled again then it is necessary to clear **CFG_LOCK_0** before.

The Charge Pump will also stay enabled in the SBC Stop, Sleep, Restart or Fail-Safe Mode if it was not disabled before entering the respective mode. It does not switch-Off due to overvoltage.

Diagnosis is available by checking the bit **CP_EN**.

System Features

5.3.1 Electrical Characteristics for Charge Pump

Table 10 Electrical Characteristics

$V_S = 5.5\text{ V to }28\text{ V}$; $T_j = -40^\circ\text{C to }+150^\circ\text{C}$; SBC Normal Mode; all voltages with respect to ground; positive current defined flowing into pin (unless otherwise specified)

Parameter	Symbol	Values			Unit	Note or Test Condition	Number
		Min.	Typ.	Max.			
Charge Pump Output Voltage	V_{CP_1}	$V_S + 4.5$	–	$V_S + 6.5$	V	¹⁾ $V_S = 5.5\text{V}$; $I_{CP} = -40\mu\text{A}$; $C_L = 3.3\text{nF}$	P_5.3.1
Charge Pump Output Voltage	V_{CP_2}	$V_S + 9.5$	–	$V_S + 14$	V	¹⁾²⁾ $V_S = 10\text{V}$; $I_{CP} = -100\mu\text{A}$; $C_L = 3.3\text{nF}$	P_5.3.2
Charge Pump Output Voltage	V_{CP_3}	$V_S + 10$	–	$V_S + 16$	V	¹⁾ $V_S \geq 13.5\text{V}$; $I_{CP} = -200\mu\text{A}$; $C_L = 3.3\text{nF}$	P_5.3.3
Maximum Charge Pump Output Current	I_{CP}	200	–	1200	μA	¹⁾²⁾ $V_{CP} = V_S + 10\text{V}$; $V_S \geq 13.5\text{V}$; $C_L = 3.3\text{nF}$	P_5.3.4
Charge Pump Leakage Current	$I_{CP,LK}$	–	0.5	2	μA	²⁾ $V_{CP} = 0\text{V} = \text{Off}$; $V_S = 13.5\text{V}$	P_5.3.5
Charge Pump Enabling Time	t_{CP_ON}	–	95	200	μs	¹⁾²⁾ CSN = High to $V_{CP} > V_S + 10\text{V}$; $V_S = 13.5\text{V}$; $C_L = 3.3\text{nF}$	P_5.3.6
Charge Pump Disabling Time	t_{CP_OFF}	–	45	65	μs	¹⁾²⁾ CSN = High to $V_{CP} < V_S + 2\text{V}$; $V_S = 13.5\text{V}$; $C_L = 3.3\text{nF}$	P_5.3.7

1) Applies for the default frequency setting. See also SPI bits [2MHZ_FREQ](#)

2) Not subject to production test, specified by design.

System Features

5.4 High-Voltage Measurement Interface

5.4.1 Block Description

This function provides the possibility to measure a voltage, e.g. the unbuffered battery voltage, with the protected WK/VSENSE HV-input. The measured voltage is routed out at FO/GPIO in case it is not configured as FO.

A simple external voltage divider needs to be placed to provide the appropriate voltage level to the microcontroller A/D converter input. For power-saving reasons, the function is available only in SBC Normal Mode and it is disabled in all other SBC modes.

The benefit of the function is that the signal is measured by a HV-input pin and that there is no current flowing through the resistor divider during low-power modes.

The functionality is shown in a simplified application diagram in [Figure 46](#).

5.4.2 Functional Description

This measurement function is by default disabled. In this case, WK/VSENSE and FO/GPIO have their default functionality. The switch S_MEAS is open for this configuration (see [Figure 46](#)), i.e. there is no connection between the pins. The measurement function can be enabled via the SPI bit **WK_MEAS**. If **WK_MEAS** is set to '1', then the measurement function is enabled and the switch S_MEAS is closed in SBC Normal Mode. S_MEAS is open in all other SBC modes. In this function the pull-up and pull-down currents of WK/VSENSE and FO/GPIO are disabled and the internal WK/VSENSE and FO/GPIO signals are gated. In addition, the settings for WK/VSENSE and FO/GPIO in the registers **WK_PUPD_CTRL**, **WK_CTRL_1** and **GPIO_CTRL** are ignored but changing these setting is not prevented. The registers **WK_STAT_0**, **WK_STAT_1** and **WK_LVL_STAT** are not updated with respect to the inputs WK/VSENSE and FO/GPIO. However, if only WK/VSENSE or GPIO WK are set as wake sources and a SBC Sleep Mode command is set, then the **SPI_FAIL** flag is set and the SBC changes into SBC Restart Mode (see Chapter 5.1 also for wake capability of WK/VSENSE and GPIO WK).

If **WK_MEAS** is set then neither the FO (including the FO test via **FO_ON**) nor the GPIO functionality or wake functionality is available. Trying to change the **GPIO_CTRL** configurations will set the **SPI_FAIL**.

If FO/GPIO is configured as FO or any other GPIO configuration, then **WK_MEAS** cannot be set and **SPI_FAIL** is triggered, i.e. FO/GPIO must be first set Off initially.

Table 11 Differences between Normal WK Function and Measurement Function

Affected Settings/Modules for WK/VSENSE and FO/GPIO Inputs	WK_MEAS = 0	WK_MEAS = 1
S_MEAS configuration	'open'	'closed' in SBC Normal Mode, 'open' in all other SBC Modes but configuration is kept
Internal WK/VSENSE & FO/GPIO signal processing	Default wake and level signaling function, WK_STAT_0 , WK_STAT_1 and WK_LVL_STAT are updated accordingly	WK/VSENSE and FO/GPIO signals are gated internally, WK_STAT_0 , WK_STAT_1 and WK_LVL_STAT are not updated

System Features

Table 11 Differences between Normal WK Function and Measurement Function (cont'd)

Affected Settings/Modules for WK/VSENSE and FO/GPIO Inputs	WK_MEAS = 0	WK_MEAS = 1
WK_EN , GPIO configured as WK	Wake-up via WK/VSENSE and GPIO WK possible	Setting the wake enable bits is ignored, i.e. the measurement function has priority but the bits can be set. If only WK_EN and/or GPIO as WK are set while trying to go to SBC Sleep Mode, then the SPI_FAIL flag is set and the SBC changes into SBC Restart Mode
SBC Fail-Safe Mode behavior	WK/VSENSE is automatically activated as wake source; see Table 22 for GPIO behavior	Measurement function configuration is kept, switch S_MEAS is open
WK_PUPD_CTRL	normal configuration is possible	no pull-up or pull-down enabled
FO functionality	FO functionality is available if configured accordingly	FO functionality is not available. FO/GPIO must be set to Off before setting WK_MEAS . Otherwise the SPI_FAIL flag is set.

*Note: There is a diode in series to the switch S_MEAS (not shown in the **Figure 46**), which influences the temperature behavior of the switch. See also **Figure 13**.*

System Features

5.4.3 Electrical Characteristics for Measurement Interface

Table 12 Electrical Characteristics

$V_S = 5.5\text{ V to }28\text{ V}$; $T_j = -40^\circ\text{C to }+150^\circ\text{C}$; SBC Normal Mode; all voltages with respect to ground; positive current defined flowing into pin (unless otherwise specified)

Parameter	Symbol	Values			Unit	Note or Test Condition	Number
		Min.	Typ.	Max.			
Input leakage current	$I_{WK_MEAS_LK}$	-2		2	μA	$0\text{ V} < V_{WK_IN} < V_S + 0.3\text{V}$ Same parameter as P_10.3.5;	P_5.4.1
Drop Voltage across S_MEAS switch between WK/VSENSE and FO/GPIO when enabled for voltage measurement;	V_{Drop,S_MEAS}	40	160	250	mV	¹⁾ $4\text{V} < V_{WK_IN} < V_S + 0.3\text{V}$; $I_{WK1} = 200\mu\text{A}$; $T_j = 25^\circ\text{C}$ Refer to Figure 13	P_5.4.2

1) Not subject to production test; specified by design

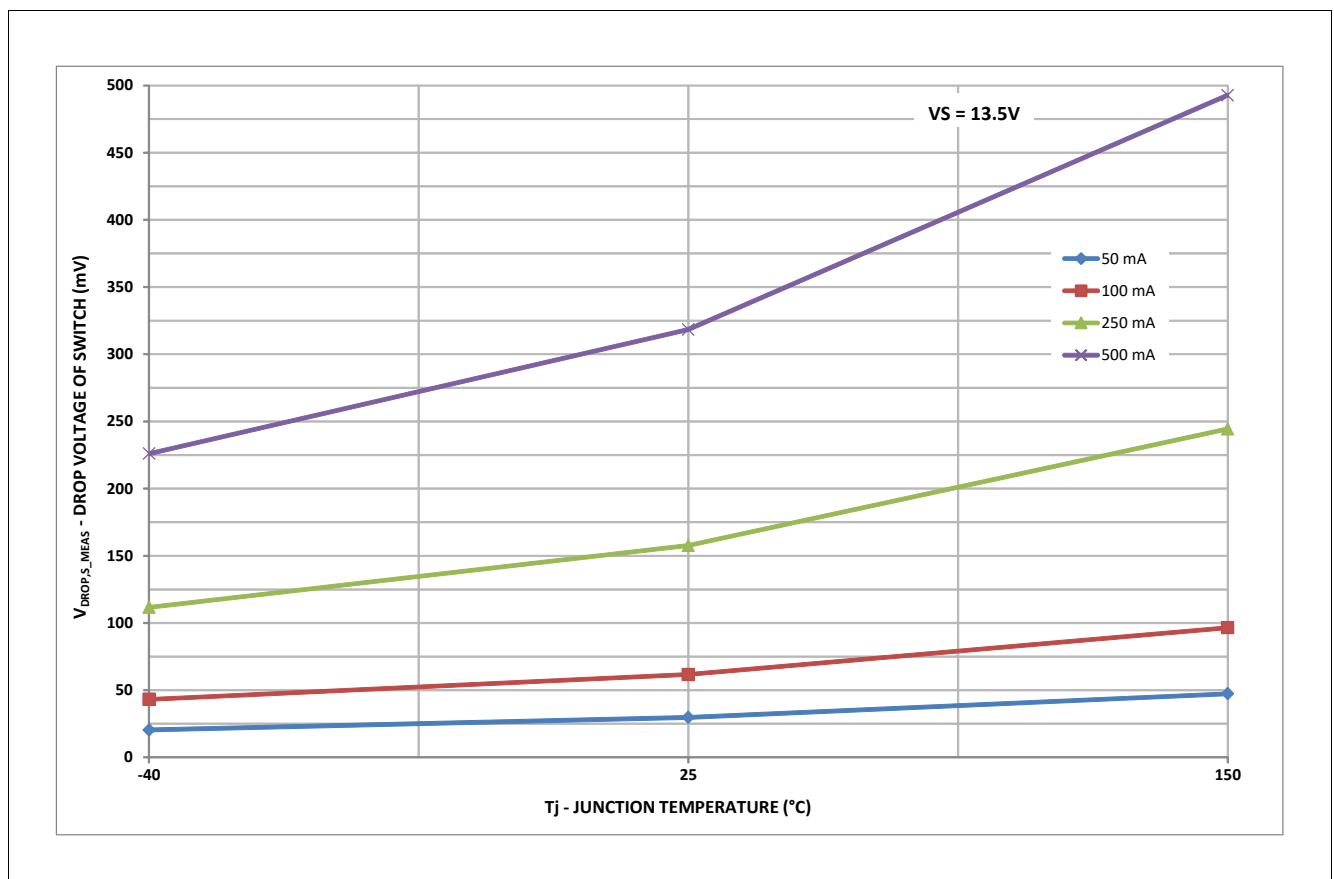

Figure 13 Typical Drop Voltage Characteristics of switch S_MEAS (between WK/VSENSE & FO/GPIO)

System Features

5.5 Spread Spectrum Modulation Frequency Function

The spread spectrum modulation frequency function can be used to reduce electromagnetic emissions for the charge pump.

The spread spectrum function can be enabled and configured by the bits **SS_MOD_FR**.

The spread spectrum function is derived from the internal 2MHz oscillator (~0.5µs period). The calculations below are applied to the 2.0MHz setting (**2MHZ_FREQ** = '001' (for all the other frequencies the values can be derived).

There is a counter adjusting the oscillator step values up and down. There is a maximum of 32 steps for the counter available. For the frequency range **2MHZ_FREQ** = '0xx' we can choose following modulation frequencies:

Table 13 Deriving the Modulation Frequency Steps

Setting	Periods / Step Width	Typ. Resulting Period	Typ. Modulation Frequency
SS_MOD_FR = '11'	0.5us / 1 period of 0.5us	16us	1/16us = 62.5 kHz
SS_MOD_FR = '10'	1.0us / 2 periods of 0.5us	32us	1/32us = 31.25 kHz
SS_MOD_FR = '01'	2.0us / 4 periods of 0.5us	64us	1/64us = 15.625 kHz

6 Voltage Regulator 1

6.1 Block Description

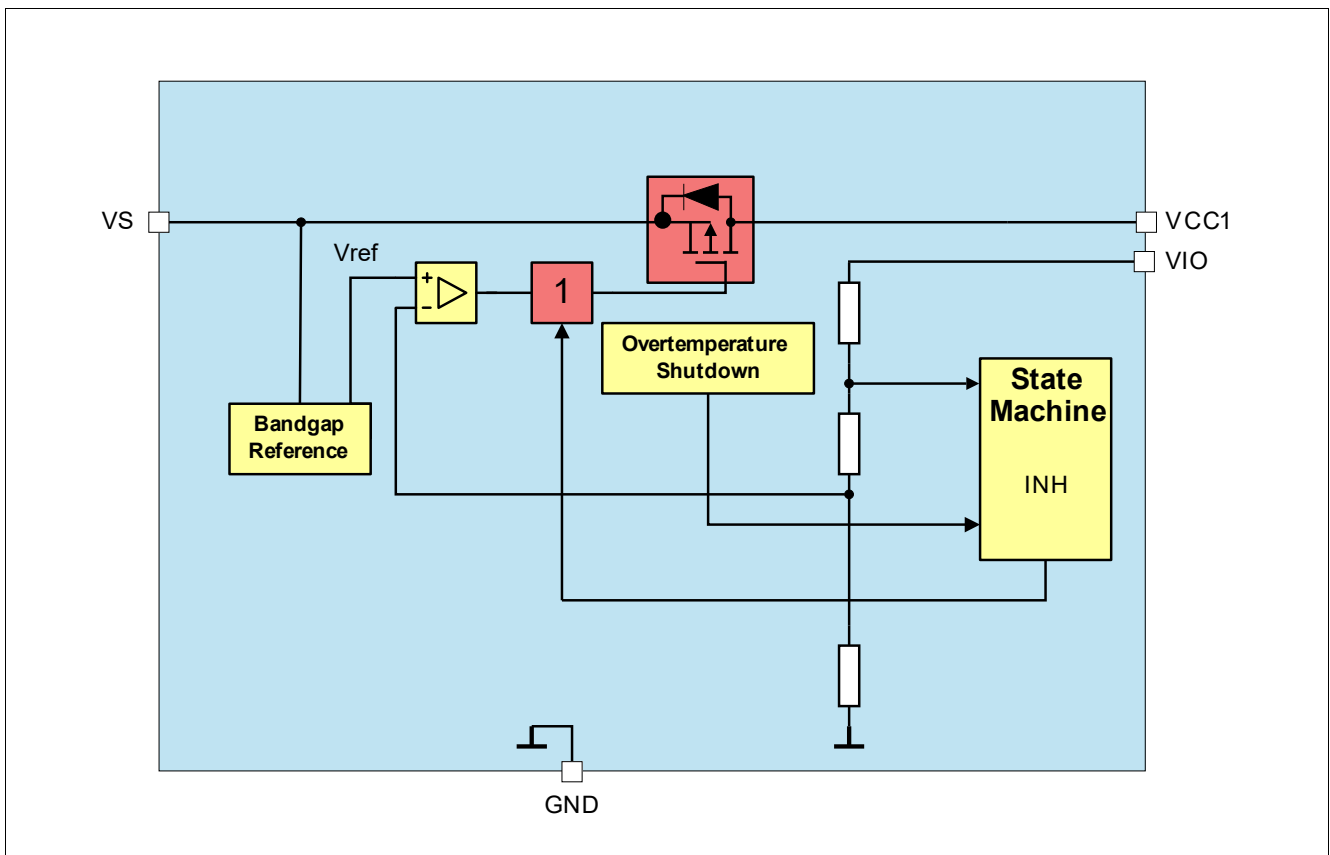

Figure 14 Module Block Diagram

Functional Features

- 5V low-dropout linear voltage regulator
- Undervoltage monitoring with adjustable reset level, VCC1 prewarning and VCC1 short circuit detection ($V_{RT1/2/3/4}$, $V_{PW,f}$). Please refer to [Chapter 12.5](#) and [Chapter 12.6](#) for more information.
- Short circuit detection and switch Off with undervoltage fail threshold, device enters SBC Fail-Safe Mode
- $\geq 1\mu\text{F}$ ceramic capacitor at voltage output for stability, with $\text{ESR} < 1\Omega$ @ $f = 10\text{ kHz}$, to achieve the voltage regulator control loop stability based on the safe phase margin (bode diagram).
- Output current limit $I_{VCC1,lim}$ configurable via SPI up to I_{VCC1,lim_11} .

Voltage Regulator 1

6.2 Functional Description

The Voltage Regulator 1 (=VCC1) is always enabled in SBC Normal, Stop and Restart Mode and is disabled in SBC Sleep and in Fail-Safe Mode. VCC1 is the voltage regulator output. VIO is the regulation feedback, supervision input and the supply for the digital in- and outputs. Therefore, the pins VCC1 and VIO must always be connected.

Current Limitation Configurations:

The regulator can provide an output current up to $I_{VCC1,lim}$. The current limitation threshold can be adjusted with the bits **ICC1_LIM_ADJ**. A soft-start feature is implemented that limits the current to the lowest value during start-up of VCC1 as long as RSTN is Low. After t_{RD1} has expired, the default value is resumed after power-up or the configured value after SBC Sleep- or Fail-Safe Mode.

Table 14 Current Limitation Configurations

SPI Setting ICC1_LIM_ADJ	Typ. Limitation Current	Note
'00'	0.75 A	default value, recommended setting
'01'	1.0 A	setting for maximum peak load current / large external capacitor values
'10'	1.2 A	setting not recommended
'11'	1.5 A	setting not recommended

For low-quiescent current reasons, the output voltage accuracy is decreased in SBC Stop Mode because a less accurate low-power mode regulator is active for very small loads. If the load current on VCC1 exceeds the selected threshold ($I_{VCC1,Ipeak1,r}$ or $I_{VCC1,Ipeak2,r}$) then the high-power mode regulator is also activated to support an optimum dynamic load behavior. The current consumption increases by typ. 2.9mA. The SBC Mode stays unchanged.

If the load current on VCC1 falls below the selected threshold ($I_{VCC1,Ipeak1,f}$ or $I_{VCC1,Ipeak2,f}$), then the low-quiescent current mode is resumed again by disabling the high-power mode regulator.

Both regulators (low-power mode and high-power mode) are active in SBC Normal Mode.

Two different active peak thresholds can be selected via SPI:

- **I_PEAK_TH** = '0' (default): the lower VCC1 active peak threshold 1 is selected with lowest quiescent current consumption in SBC Stop Mode ($I_{Stop_1,25}$, $I_{Stop_1,85}$);
- **I_PEAK_TH** = '1': the higher VCC1 active peak threshold 2 is selected with an increased quiescent current consumption in SBC Stop Mode ($I_{Stop_2,25}$, $I_{Stop_2,85}$);

Voltage Regulator 1

6.3 Electrical Characteristics

Table 15 Electrical Characteristics

$V_S = 5.5\text{ V to }28\text{ V}$; $T_j = -40^\circ\text{C to }+150^\circ\text{C}$; all voltages with respect to ground, positive current flowing into pin (unless otherwise specified)

Parameter	Symbol	Values			Unit	Note or Test Condition	Number
		Min.	Typ.	Max.			
Output Voltage including Line and Load Regulation	$V_{CC1,out1}$	4.9	5.0	5.1	V	¹⁾ SBC Normal Mode; $10\mu\text{A} < I_{VCC1} < 150\text{mA}$;	P_7.3.1
Output Voltage including Line and Load Regulation (Full Load Current Range)	$V_{CC1,out2}$	4.9	5.0	5.1	V	¹⁾ SBC Normal Mode; $6\text{V} < V_S < 28\text{V}$; $10\mu\text{A} < I_{VCC1} < 250\text{mA}$	P_7.3.18
Output Voltage including Line and Load Regulation (Higher Accuracy Range)	$V_{CC1,out3}$	4.95	–	5.05	V	¹⁾²⁾ SBC Normal Mode; $20\text{mA} < I_{VCC1} < 80\text{mA}$; $8\text{V} < V_S < 18\text{V}$; $25^\circ\text{C} < T_j < 125^\circ\text{C}$	P_7.3.2
Output Voltage including Line and Load Regulation (Low-Power Mode)	$V_{CC1,out4}$	4.8	5.0	5.2	V	SBC Stop Mode; $10\mu\text{A} < I_{VCC1} < I_{VCC1,lpeak}$	P_7.3.3
Drop-OUt Voltage	$V_{CC1,d2}$	–	–	500	mV	$I_{VCC1} = 250\text{mA}$, $V_S = 5\text{V}$	P_7.3.8
VCC1 Active Peak Threshold 1 (Transition threshold between low-power and high-power mode regulator)	$I_{VCC1,lpeak1,r}$	1.5	3.25	5.0	mA	²⁾ I_{CC1} rising; $V_S = 13.5\text{V}$; $I_PEAK_TH = '0'$	P_7.3.9
VCC1 Active Peak Threshold 1 (Transition threshold between high-power and low-power mode regulator)	$I_{VCC1,lpeak1,f}$	1.2	2.3	3.5	mA	²⁾ I_{CC1} falling; $V_S = 13.5\text{V}$; $I_PEAK_TH = '0'$	P_7.3.10
VCC1 Active Peak Threshold 2 (Transition threshold between low-power and high-power mode regulator)	$I_{VCC1,lpeak2,r}$	2.5	6.25	10	mA	²⁾ I_{CC1} rising; $V_S = 13.5\text{V}$; $I_PEAK_TH = '1'$	P_7.3.11
VCC1 Active Peak Threshold 2 (Transition threshold between high-power and low-power mode regulator)	$I_{VCC1,lpeak2,f}$	2.2	4.5	8	mA	²⁾ I_{CC1} falling; $V_S = 13.5\text{V}$; $I_PEAK_TH = '1'$	P_7.3.12
Overcurrent Limitation ($ICC1_LIM_ADJ = '00'$)	I_{VCC1,lim_00}	0.6	0.75	0.95	A	²⁾³⁾ current flowing out of pin, $V_{CC1} = 0\text{V}$, $V_S > 6\text{V}$, default value	P_7.3.13

Voltage Regulator 1

Table 15 Electrical Characteristics (cont'd)

$V_S = 5.5\text{ V to }28\text{ V}$; $T_j = -40^\circ\text{C to }+150^\circ\text{C}$; all voltages with respect to ground, positive current flowing into pin (unless otherwise specified)

Parameter	Symbol	Values			Unit	Note or Test Condition	Number
		Min.	Typ.	Max.			
Overcurrent Limitation (ICC1_LIM_ADJ = '01')	I_{VCC1,lim_01}	0.8	1.0	1.25	A	²⁾³⁾ current flowing out of pin, $V_{CC1} = 0\text{V}$, $V_S > 6\text{V}$	P_7.3.19
Overcurrent Limitation (ICC1_LIM_ADJ = '10')	I_{VCC1,lim_10}	0.96	1.25	1.60	A	²⁾³⁾ current flowing out of pin, $V_{CC1} = 0\text{V}$, $V_S > 6\text{V}$	P_7.3.20
Overcurrent Limitation (ICC1_LIM_ADJ = '11')	I_{VCC1,lim_11}	1.1	1.5	1.95	A	²⁾³⁾ current flowing out of pin, $V_{CC1} = 0\text{V}$, $V_S > 6\text{V}$	P_7.3.21

- 1) In SBC Stop Mode, the specified output voltage tolerance applies when I_{VCC1} has exceeded the selected active peak threshold ($I_{VCC1,lpeak1,r}$ or $I_{VCC1,lpeak2,r}$) but with increased current consumption.
- 2) Not subject to production test, specified by design.
- 3) Current limitation value is max. 20% higher for $V_{POR,f} < V_S < 6\text{ V}$ to optimize low-drop operation behavior.

7 Voltage Regulator 2

7.1 Block Description

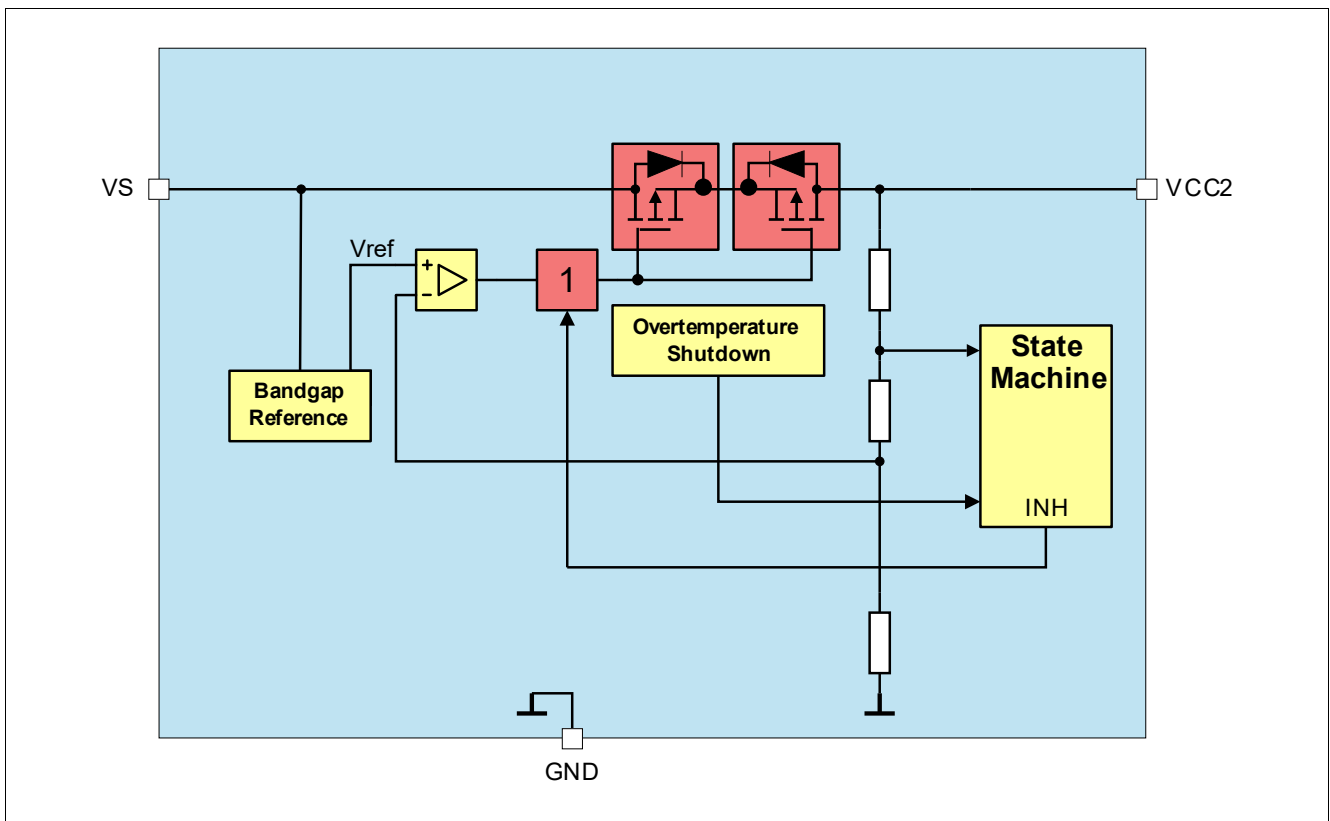

Figure 15 Module Block Diagram

Functional Features

- 5 V low drop-out linear voltage regulator
- Protected against short to battery voltage, e.g. for off-board sensor supply
- Can also be used for CAN supply
- VCC2 undervoltage monitoring. Please refer to [Chapter 12.7](#) for more information
- Can be active in SBC Normal, SBC Stop, and SBC Sleep Mode (not SBC Fail-Safe Mode)
- VCC2 switches Off after entering SBC Restart Mode. Switch Off is latched, LDO must be enabled via SPI after shutdown.
- Overtemperature protection
- $\geq 470\text{nF}$ ceramic capacitor at output voltage for stability, with $\text{ESR} < 1\Omega @ f = 10\text{ kHz}$, to achieve the voltage regulator control loop stability based on the safe phase margin (bode diagram).
- Output current capability up to $I_{\text{VCC2,lim}}$

Voltage Regulator 2

7.2 Functional Description

In SBC Normal Mode VCC2 can be switched On or Off via SPI.

For SBC Stop- or Sleep Mode, the VCC2 has to be switched On or Off in SBC Normal Mode before entering the respective SBC mode. The regulator is automatically switched Off in SBC Restart Mode

The regulator can provide an output current up to $I_{VCC2,lim}$.

For low-quiescent current reasons, the output voltage accuracy is decreased in SBC Stop and Sleep Mode (if enabled) because a low-power mode regulator with a lower accuracy ($V_{CC2,out4}$) is active for small loads. If the load current on VCC2 exceeds $I_{VCC2} > I_{VCC2,ipeak,r}$ then the high-power mode regulator will also be enabled to support an optimum dynamic load behavior. The current consumption increases by typ. 2.9mA. The SBC Mode stays unchanged.

If the load current on VCC2 falls below the threshold ($I_{VCC2} < I_{VCC2,ipeak,f}$), then the low-quiescent current mode is resumed by disabling the high-power mode regulator.

Both regulators are active in SBC Normal Mode.

Note: If the VCC2 output voltage is supplying external off-board loads, the application must consider the series resonance circuit built by cable inductance and decoupling capacitor at the load. Sufficient damping must be provided.

Note: To avoid excessive repetitive short-circuit conditions, It is recommended to detect the shutdown reason for VCC2 and keep the regulator Off after multiple over-temperature shutdowns.

7.2.1 Short to Battery Protection

The output stage is protected for short to VBAT. No inverse current flows if the voltage on VCC2 is higher than the nominal output voltage.

Voltage Regulator 2

7.3 Electrical Characteristics

Table 16 Electrical Characteristics

$V_S = 5.5\text{ V to }28\text{ V}$; $T_j = -40^\circ\text{C to }+150^\circ\text{C}$; all voltages with respect to ground, positive current flowing into pin (unless otherwise specified)

Parameter	Symbol	Values			Unit	Note or Test Condition	Number
		Min.	Typ.	Max.			
Output Voltage Including Line and Load Regulation (Full Load Current Range)	$V_{CC2,out1}$	4.9	5.0	5.1	V	¹⁾ SBC Normal Mode; $10\mu\text{A} < I_{VCC2} < 100\text{mA}$ $6\text{V} < V_S < 28\text{V}$	P_8.3.1
Output Voltage Including Line and Load Regulation	$V_{CC2,out2}$	4.9	5.0	5.1	V	¹⁾ SBC Normal Mode; $10\mu\text{A} < I_{VCC2} < 50\text{mA}$	P_8.3.2
Output Voltage Including Line and Load Regulation (Higher Accuracy Range)	$V_{CC2,out3}$	4.95	5.0	5.05	V	²⁾ SBC Normal Mode; $10\mu\text{A} < I_{VCC2} < 5\text{mA}$ $8\text{V} < V_S < 18\text{V}$	P_8.3.3
Output Voltage Including Line and Load Regulation (Low-Power Mode)	$V_{CC2,out4}$	4.9	5.05	5.2	V	SBC Stop / Sleep Mode; $10\mu\text{A} < I_{VCC2} < I_{VCC2,lpeak}$	P_8.3.4
Drop-Out Voltage	$V_{CC2,d1}$	–	–	500	mV	$I_{VCC2} = 30\text{mA}$ $V_S = 5\text{V}$	P_8.3.5
VCC2 Active Peak Threshold (Transition threshold between low-power and high-power mode regulator)	$I_{VCC2,lpeak,r}$	2.3	3.3	4.4	mA	²⁾ I_{CC2} rising; $V_S = 13.5\text{V}$;	P_8.3.6
VCC2 Active Peak Threshold (Transition threshold between high-power and low-power mode regulator)	$I_{VCC2,lpeak,f}$	1.4	2.2	3.2	mA	²⁾ I_{CC2} falling; $V_S = 13.5\text{V}$;	P_8.3.7
Overcurrent limitation	$I_{VCC2,lim}$	100	–	450	mA	²⁾ current flowing out of pin, $V_{CC2} = 0\text{V}$	P_8.3.8

1) In SBC Stop Mode, the specified output voltage tolerance applies when I_{VCC2} has exceeded the selected active peak threshold ($I_{VCC2,lpeak,r}$) but with increased current consumption.

2) Not subject to production test, specified by design.

Voltage Regulator 2

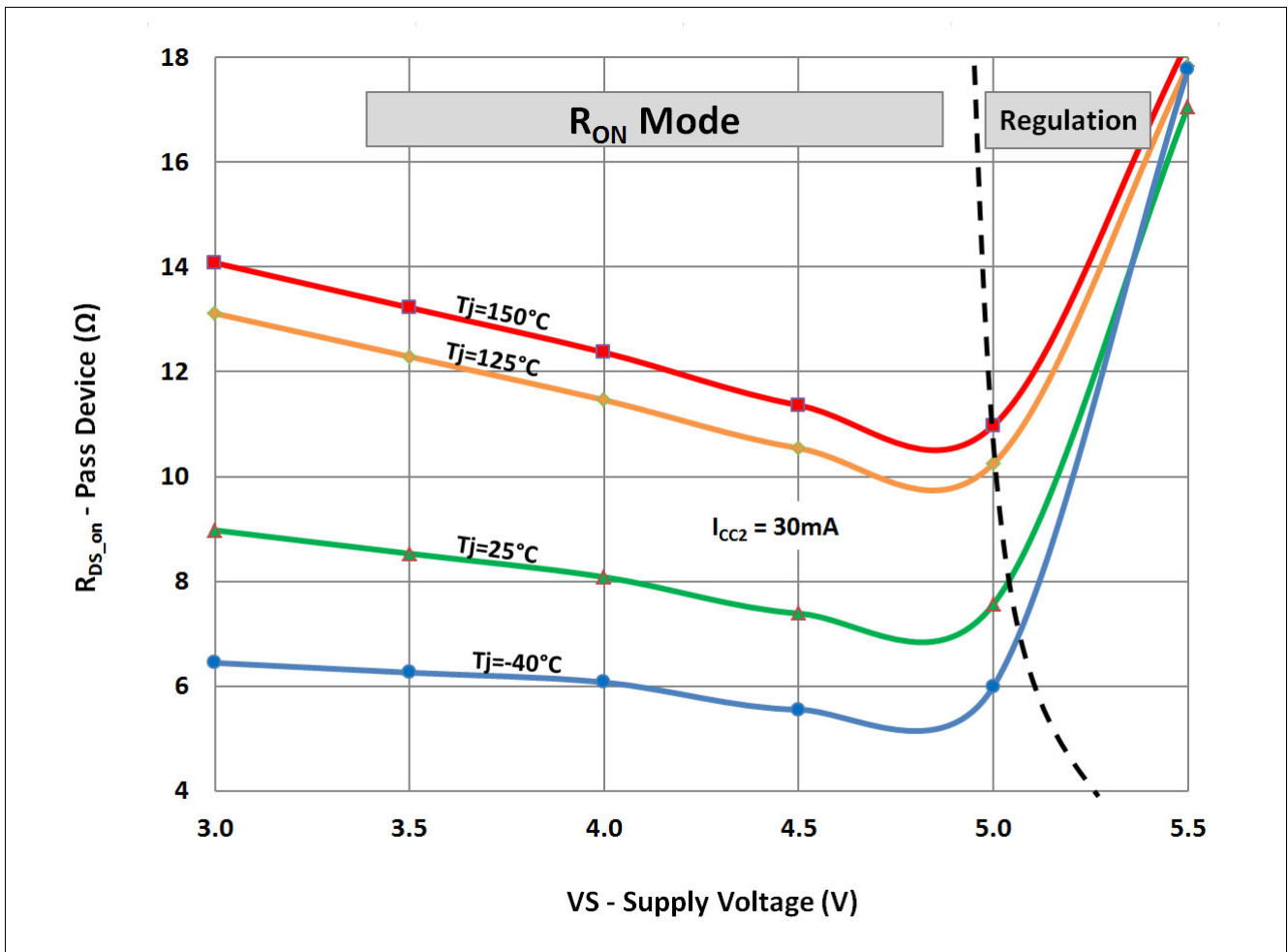

Figure 16 Typical on-resistance of VCC2 pass device during linear (R_{ON}) mode for I_{CC2} = 30mA

Voltage Regulator 2

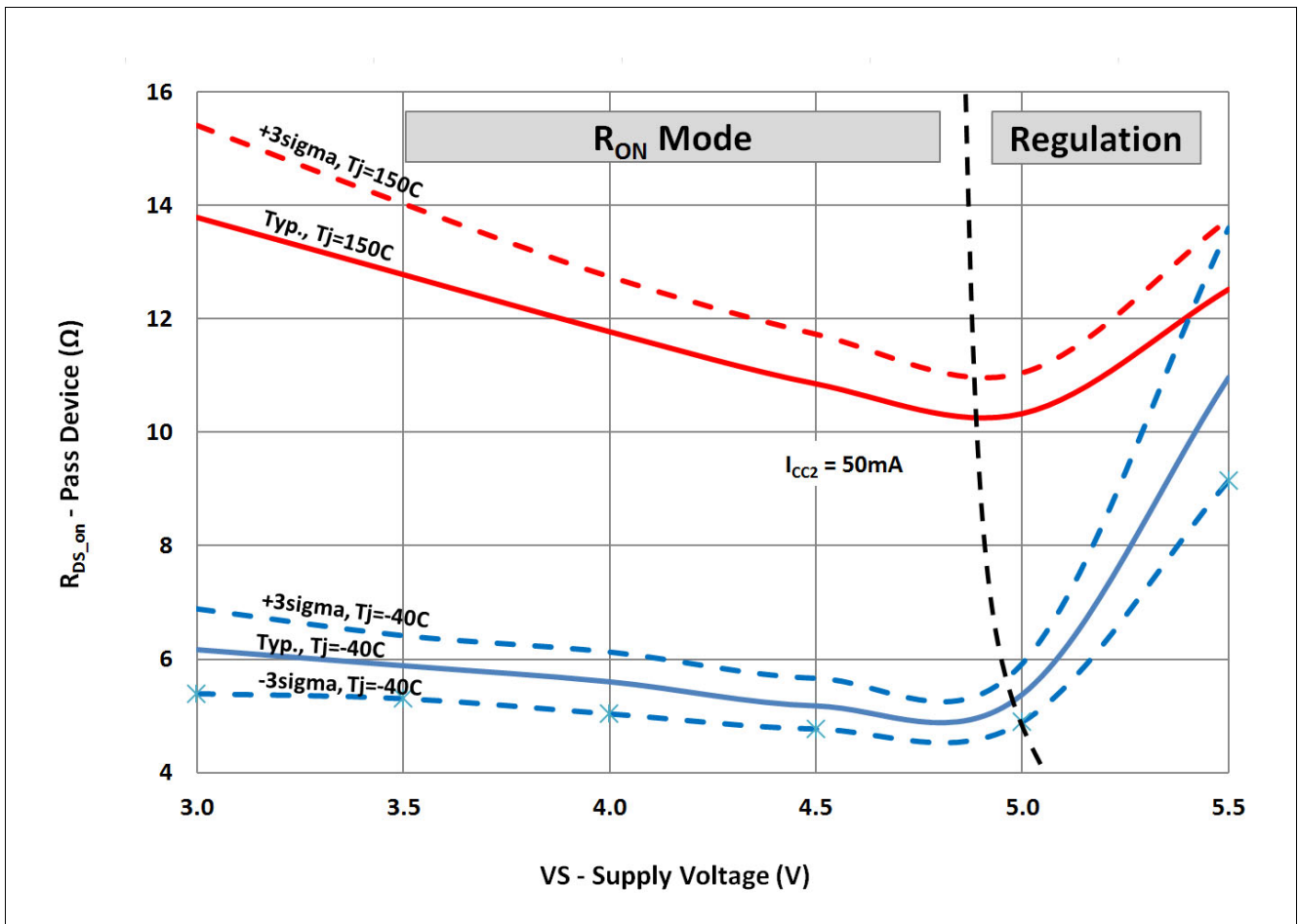

Figure 17 On-resistance range of VCC2 pass device during linear (R_{ON}) mode for $I_{CC2} = 50\text{mA}$

8 High-Speed CAN FD Transceiver

8.1 Block Description

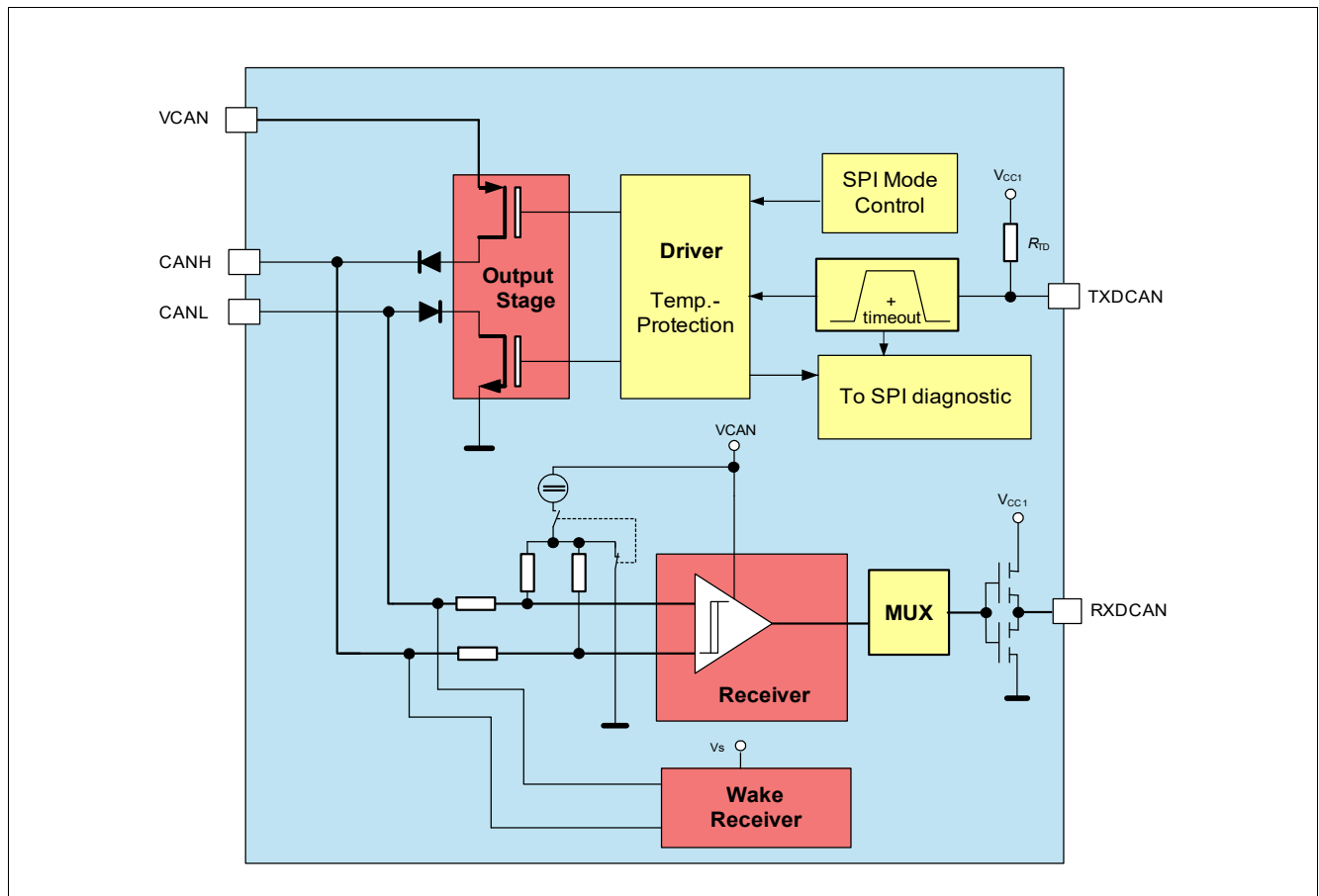

Figure 18 Functional Block Diagram

8.2 Functional Description

The Controller Area Network (CAN) transceiver part of the SBC provides High-Speed (HS) differential mode data transmission (up to 2Mbaud) and reception in automotive and industrial applications. It works as an interface between the CAN protocol controller and the physical bus lines compatible to ISO 11898-2:2016 and SAE J2284.

The CAN FD transceiver offers low-power modes to reduce current consumption. This supports networks with partially powered down nodes. To support software diagnostic functions, a CAN Receive-only Mode is implemented.

It is designed to provide excellent passive behavior when the transceiver is switched Off (mixed networks, clamp 15/30 applications).

A wake-up from the CAN Wake Capable Mode is possible via a message on the bus. Thus, the microcontroller can be powered down or idled and is woken up by the CAN bus activities.

The CAN transceiver is designed to withstand the severe conditions of automotive applications and to support 12V applications.

The transceiver can also be configured to Wake Capable in order to save current and to ensure a safe transition from Normal to Sleep Mode (to avoid losing messages).

High-Speed CAN FD Transceiver

Figure 19 shows the possible transceiver mode transition when changing the SBC mode.

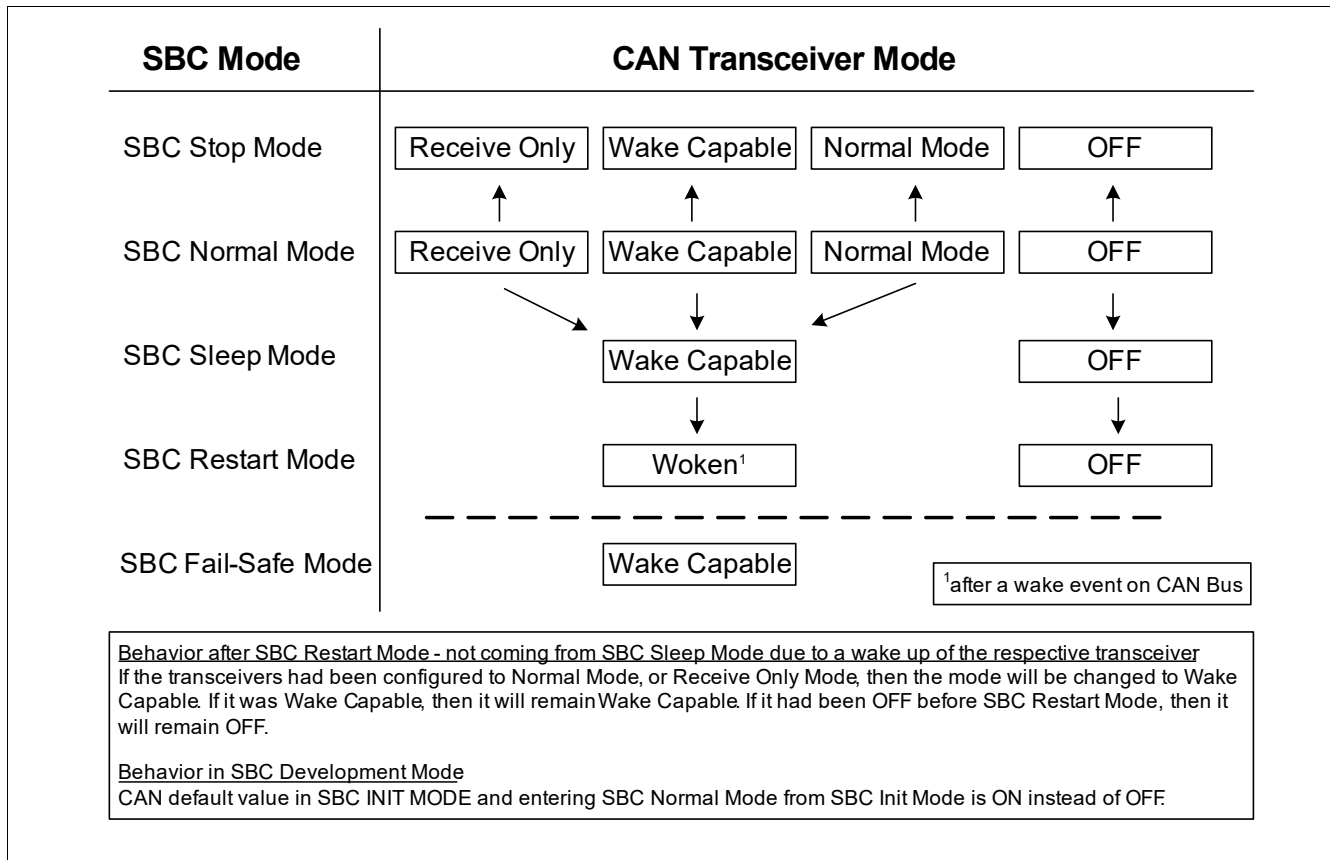

Figure 19 CAN Mode Control Diagram

CAN FD Support

CAN FD stands for ‘CAN with Flexible Data Rate’. It is based on the well-established CAN protocol as specified in ISO 11898-1. CAN FD still uses the CAN bus arbitration method. The benefit is that the bit rate can be increased by switching to a shorter bit time at the end of the arbitration process and then to return to the longer bit time at the CRC delimiter, before the receivers transmit their acknowledge bits. See also Figure 20. In addition, the effective data rate is increased by allowing longer data fields. CAN FD allows the transmission of up to 64 data bytes compared to the 8 data bytes from the standard CAN.

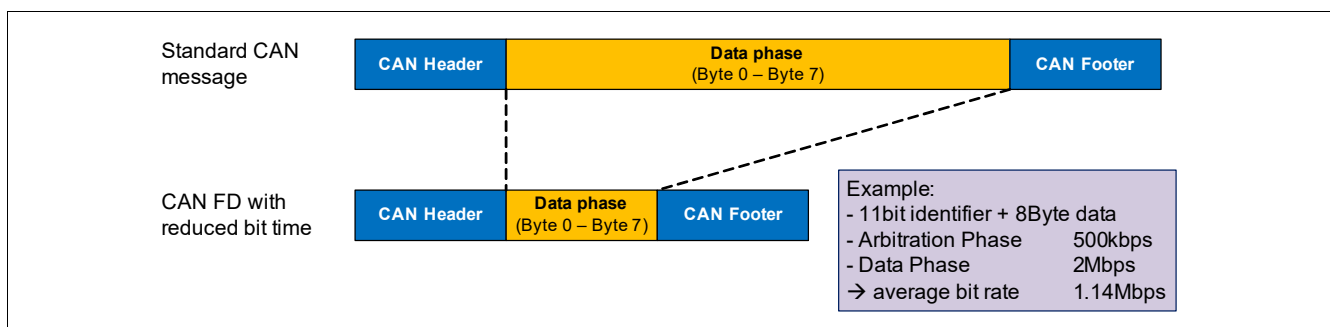

Figure 20 Bite Rate Increase with CAN FD vs. Standard CAN

Not only the physical layer must support CAN FD but also the CAN controller. In case the CAN controller is not able to support CAN FD then the respective CAN node must at least tolerate CAN FD communication. This CAN FD tolerant mode is realized in the physical layer.

High-Speed CAN FD Transceiver

8.2.1 CAN Off Mode

The CAN Off Mode is the default mode after power-up of the SBC. It is available in all SBC Modes and is intended to completely stop CAN activities or when CAN communication is not needed. In CAN Off Mode, a wake-up event on the bus is ignored.

8.2.2 CAN Normal Mode

The CAN Transceiver is enabled via SPI. CAN Normal Mode is designed for normal data transmission/reception within the HS CAN network. The Mode is available in SBC Normal Mode.

Transmission:

The signal from the microcontroller is applied to the TXDCAN input of the SBC. The bus driver switches the CANH/L output stages to transfer this input signal to the CAN bus lines.

Enabling sequence:

The CAN transceiver requires an enabling time $t_{CAN,EN}$ before a message can be sent on the bus. This means that the TXDCAN signal can only be pulled Low after the enabling time. If this is not ensured, then the TXDCAN needs to be set back to High (=recessive) until the enabling time is completed. Only the next dominant bit is transmitted on the bus. **Figure 21** shows different scenarios and explanations for CAN enabling.

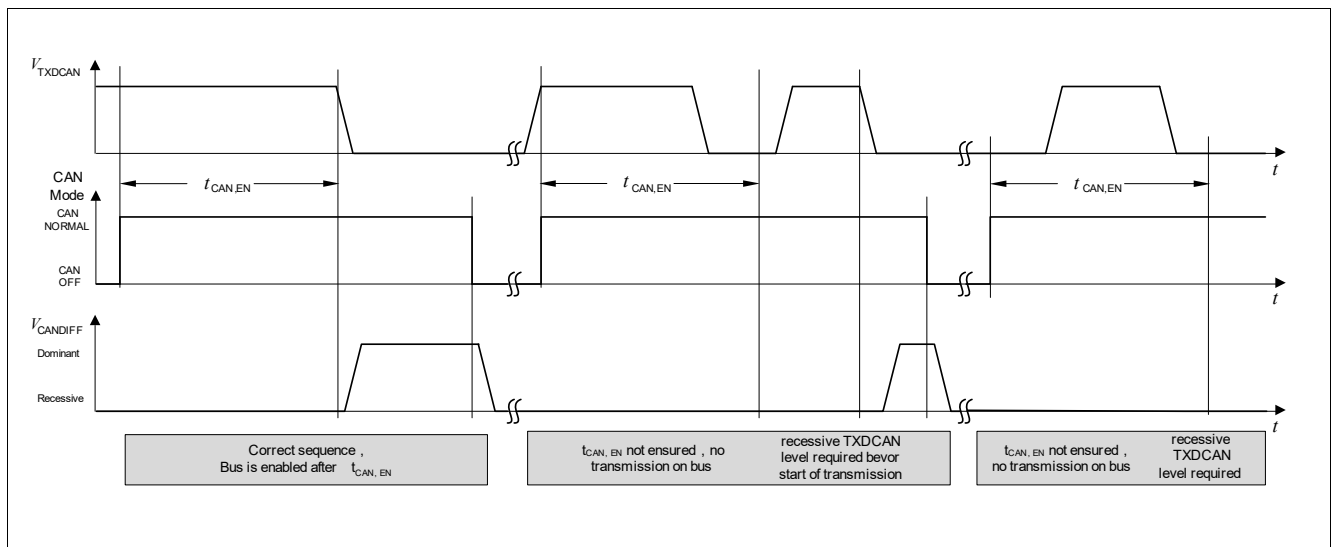

Figure 21 CAN Transceiver Enabling Sequence

Reduced Electromagnetic Emission:

To reduce electromagnetic emissions (EME), the bus driver controls CANH/L slopes symmetrically.

Reception:

Analog CAN bus signals are converted into digital signals at RXDCAN via the differential input receiver.

High-Speed CAN FD Transceiver

8.2.3 CAN Receive Only Mode

In CAN Receive Only Mode (RX only), the driver stage is de-activated but reception is still operational. This mode is accessible by an SPI command in SBC Normal Mode and in SBC Stop Mode.

Note: The transceiver is still properly working in Receive Only mode even if VCAN is not available because of an independent receiver supply.

8.2.4 CAN Wake Capable Mode

This mode can be used in SBC Stop, Sleep, Restart and Normal Mode by programming via SPI and it is used to monitor bus activities. It is automatically accessed in SBC Fail-Safe Mode. A wake-up signal on the bus results in a change of behavior of the SBC, as described in Table 17. As a signalization to the microcontroller, the RXDCAN pin is set Low and stays Low until the CAN transceiver is changed to any other mode. After a wake-up event, the transceiver can be switched to CAN Normal Mode via SPI for bus communication.

As shown in Figure 22, a wake-up pattern (WUP) is signalled on the bus by two consecutive dominant bus levels for at least t_{Wake1} (wake-up time) and less than t_{Wake2} , each separated by a recessive bus level of greater than t_{Wake1} and shorter than t_{Wake2} .

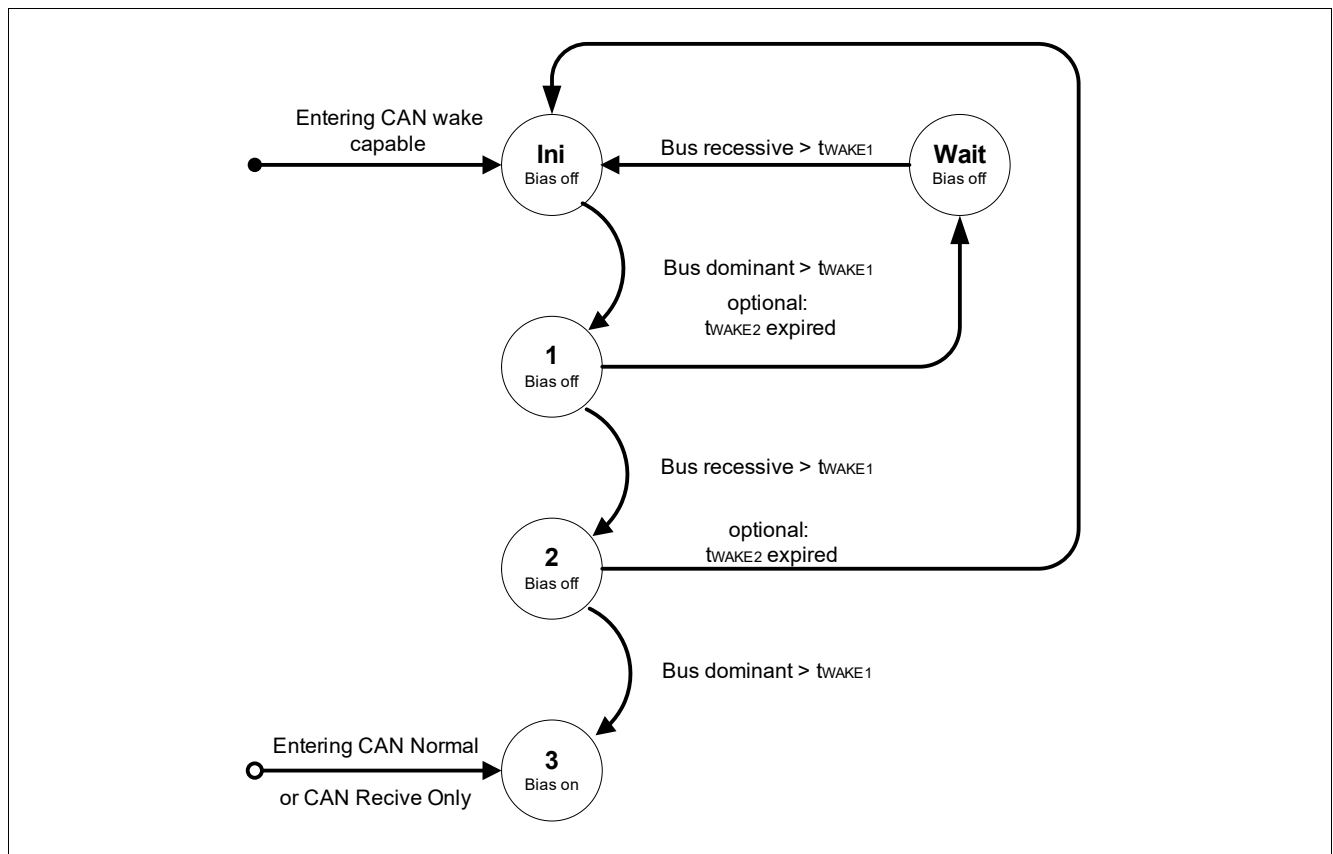

Figure 22 CAN Wake-up Pattern Detection according to the Definition in ISO 11898-2

Rearming the Transceiver for Wake Capability:

After a BUS wake-up event, the transceiver is woken. However, the CAN transceiver mode bits will still show Wake Capable (=‘01’) so that the RXDCAN signal is pulled Low. There are two possibilities how the CAN transceiver’s Wake Capable mode is enabled again after a wake-up event:

- The CAN transceiver mode must be toggled, i.e. switched from Wake Capable Mode to CAN Normal Mode, CAN Receive Only Mode or CAN Off, before switching to CAN Wake Capable Mode again.

High-Speed CAN FD Transceiver

- Rearming is done automatically when the SBC is changed to SBC Stop, SBC Sleep, or SBC Fail-Safe Mode to ensure wake-up capability.

Wake-Up in SBC Stop and Normal Mode:

In SBC Stop Mode, if a wake-up is detected, it is always signaled by the INTN output and in the **WK_STAT_0** SPI register. It is also signaled by RXDCAN pulled to Low. The same applies for the SBC Normal Mode. The microcontroller needs to set the device from SBC Stop Mode to SBC Normal Mode, there is no automatic transition to Normal Mode.

For functional safety reasons, the watchdog is automatically enabled in SBC Stop Mode after a Bus wake-up event in case it was disabled before (if bit **WD_EN_WK_BUS** was configured to High before).

Wake-Up in SBC Sleep Mode:

Wake-up is possible via a CAN message. The wake-up automatically transfers the SBC into the SBC Restart Mode and from there to Normal Mode the corresponding RXDCAN pin is set to Low. The microcontroller is able to detect the Low signal on RXDCAN and to read the wake source out of the **WK_STAT_0** register via SPI. No interrupt is generated when coming out of Sleep Mode. The microcontroller can now for example switch the CAN transceiver into CAN Normal Mode via SPI to start communication.

Table 17 Action due to CAN Bus Wake-Up

SBC Mode	SBC Mode after Wake-up	VCC1	INTN	RXDCAN
Normal Mode	Normal Mode	On	Low	Low
Stop Mode	Stop Mode	On	Low	Low
Sleep Mode	Restart Mode	Ramping Up	High	Low
Restart Mode	Restart Mode	On	High	Low
Fail-Safe Mode	Restart Mode	Ramping Up	High	Low

8.2.5 CAN Bus termination

In accordance with the CAN configuration, four types of bus terminations are allowed:

- CAN Normal Mode: VCAN/2 termination;
- CAN Receive Only Mode: VCAN/2 termination in case that VCAN is nominal supply; when VCAN UV is detected, the termination is 2.5V;
- CAN Wake Capable: GND termination: after wake-up, the termination is 2.5V;
- CAN Off: no termination necessary (bus floating).

When entering CAN Wake Capable mode the termination is only connected to GND only after the t_{silence} time has expired.

8.2.6 TXD Time-out Feature

If the TXDCAN signal is dominant for a time $t > t_{\text{TXDCAN_TO}}$, in CAN Normal Mode, the TXDCAN time-out function deactivates the transmission of the signal at the bus setting the TXDCAN pin to recessive. This is implemented to prevent the bus from being blocked permanently due to an error. The transmitter is disabled and thus switched to recessive state. The CAN SPI control bits (**CAN** on **BUS_CTRL_0**) remain unchanged and the failure is stored in the SPI flag **CAN_FAIL**. The CAN transmitter stage is activated again after the dominant time-out condition is removed and the transceiver is automatically switched back to CAN Normal Mode.

8.2.7 Bus Dominant Clamping

If the HS CAN bus signal is dominant for a time $t > t_{\text{BUS_CAN_TO}}$, in CAN Normal and Receive Only Mode a bus dominant clamping is detected and the SPI bit **CAN_FAIL** is set. The transceiver configuration stays unchanged. In order to avoid that a bus dominant clamping is detected due to a TXD time-out the bus dominant clamping filter time $t_{\text{BUS_CAN_TO}} > t_{\text{TXDCAN_TO}}$.

8.2.8 Undervoltage Detection

The voltage at the CAN supply pin is monitored in CAN Normal and Receive Only Mode. In case of VCAN undervoltage a signalization via SPI bit **VCAN_UV** is triggered and the TLE9461ES disables the transmitter stage. If the CAN supply reaches a higher level than the undervoltage detection threshold ($V_{\text{CAN}} > V_{\text{CAN_UV,r}}$), the transceiver is automatically switched back to CAN Normal Mode.

The undervoltage detection is enabled if the mode bit $\text{CAN_1} = '1'$, i.e. in CAN Normal or CAN Receive Only Mode.

High-Speed CAN FD Transceiver

8.3 Electrical Characteristics

Table 18 Electrical Characteristics

$T_j = -40^{\circ}\text{C}$ to $+150^{\circ}\text{C}$; $V_S = 5.5\text{ V}$ to 28 V ; $V_{\text{CAN}} = 4.75\text{ V}$ to 5.25 V ; $R_L = 60\ \Omega$; CAN Normal Mode; all voltages with respect to ground, positive current flowing into pin (unless otherwise specified)

Parameter	Symbol	Values			Unit	Note or Test Condition	Number
		Min.	Typ.	Max.			
CAN Bus Receiver							
Differential Receiver Threshold Voltage, recessive to dominant edge	$V_{\text{diff,rd}_N}$	–	0.80	0.90	V	$V_{\text{diff}} = V_{\text{CANH}} - V_{\text{CANL}}$; $-12\text{V} \leq V_{\text{CM}}(\text{CAN}) \leq 12\text{V}$; $0.9\text{V} \leq V_{\text{diff,D_Range}} \leq 8\text{V}$; CAN Normal Mode	P_9.3.2
Differential Receiver Threshold Voltage, dominant to recessive edge	$V_{\text{diff,dr}_N}$	0.50	0.60	–	V	$V_{\text{diff}} = V_{\text{CANH}} - V_{\text{CANL}}$; $-12\text{V} \leq V_{\text{CM}}(\text{CAN}) \leq 12\text{V}$; $-3\text{V} \leq V_{\text{diff,D_Range}} \leq 0.5\text{V}$; CAN Normal Mode	P_9.3.3
Common Mode Range	CMR	-12	–	12	V	4)	P_9.3.4
CANH, CANL Input Resistance	R_{in}	20	40	50	k Ω	CAN Normal / Wake Capable Mode; Recessive state; $-2\text{ V} \leq V_{\text{CANL/H}} \leq +7\text{ V}$	P_9.3.5
Differential Input Resistance	$R_{\text{in,diff}}$	40	80	100	k Ω	CAN Normal / Wake Capable Mode; Recessive state; $-2\text{ V} \leq V_{\text{CANL/H}} \leq +7\text{ V}$	P_9.3.6
Input Resistance Deviation between CANH and CANL	DR_i	-3	–	3	%	4) Recessive state $V_{\text{CANL}} = V_{\text{CANL/H}} = 5\text{V}$	P_9.3.7
Input Capacitance CANH, CANL versus GND	C_{in}	–	20	40	pF	1) $V_{\text{TXDCAN}} = 5\text{V}$	P_9.3.8
Differential Input Capacitance CANH versus CANL	$C_{\text{in,diff}}$	–	10	20	pF	1) $V_{\text{TXDCAN}} = 5\text{V}$	P_9.3.9
Wake-up Receiver Threshold Voltage, recessive to dominant edge	$V_{\text{diff,rd}_W}$	–	0.8	1.15	V	$-12\text{V} \leq V_{\text{CM}}(\text{CAN}) \leq 12\text{V}$; $1.15\text{V} \leq V_{\text{diff,D_Range}} \leq 8\text{V}$; CAN Wake Capable Mode	P_9.3.10
Wake-up Receiver Threshold Voltage, dominant to recessive edge	$V_{\text{diff,dr}_W}$	0.4	0.7	–	V	$-12\text{V} \leq V_{\text{CM}}(\text{CAN}) \leq 12\text{V}$; $-3\text{V} \leq V_{\text{diff,D_Range}} \leq 0.4\text{V}$; CAN Wake Capable Mode	P_9.3.11
CAN Bus Transmitter							
CANH/CANL Recessive Output Voltage (CAN Normal Mode)	$V_{\text{CANL/H_NM}}$	2.0	–	3.0	V	CAN Normal Mode $V_{\text{TXDCAN}} = V_{\text{CC1}}$; no load	P_9.3.12

High-Speed CAN FD Transceiver

Table 18 Electrical Characteristics (cont'd)

$T_j = -40^{\circ}\text{C}$ to $+150^{\circ}\text{C}$; $V_S = 5.5\text{ V}$ to 28 V ; $V_{\text{CAN}} = 4.75\text{ V}$ to 5.25 V ; $R_L = 60\ \Omega$; CAN Normal Mode; all voltages with respect to ground, positive current flowing into pin (unless otherwise specified)

Parameter	Symbol	Values			Unit	Note or Test Condition	Number
		Min.	Typ.	Max.			
CANH/CANL Recessive Output Voltage (CAN Wake Capable Mode)	$V_{\text{CANL/H_LP}}$	-0.1	–	0.1	V	CAN Wake Capable Mode; $V_{\text{TXDCAN}} = V_{\text{CC1}}$; no load	P_9.3.13
CANH, CANL Recessive Output Voltage Difference $V_{\text{diff}} = V_{\text{CANH}} - V_{\text{CANL}}$ (CAN Normal Mode)	$V_{\text{diff_r_N}}$	-500	–	50	mV	CAN Normal Mode; $V_{\text{TXDCAN}} = V_{\text{CC1}}$; no load	P_9.3.14
CANH, CANL Recessive Output Voltage Difference $V_{\text{diff}} = V_{\text{CANH}} - V_{\text{CANL}}$ (CAN Wake Capable Mode)	$V_{\text{diff_r_W}}$	-200	–	50	mV	CAN Wake Capable Mode; $V_{\text{TXDCAN}} = V_{\text{CC1}}$; no load	P_9.3.15
CANL Dominant Output Voltage	V_{CANL}	0.5	–	2.25	V	CAN Normal Mode; $V_{\text{TXDCAN}} = 0\text{V}$; $V_{\text{CAN}} = 5\text{V}$; $50\ \Omega \leq R_L \leq 65\ \Omega$	P_9.3.16
CANH Dominant Output Voltage	V_{CANH}	2.75	–	4.5	V	CAN Normal Mode; $V_{\text{TXDCAN}} = 0\text{V}$; $V_{\text{CAN}} = 5\text{V}$; $50\ \Omega \leq R_L \leq 65\ \Omega$	P_9.3.17
CANH, CANL Dominant Output Voltage Difference $V_{\text{diff}} = V_{\text{CANH}} - V_{\text{CANL}}$	$V_{\text{diff_d_N}}$	1.5	2.0	2.5	V	CAN Normal Mode; $V_{\text{TXDCAN}} = 0\text{V}$; $V_{\text{CAN}} = 5\text{V}$; $50\ \Omega \leq R_L \leq 65\ \Omega$	P_9.3.18
CANH, CANL Dominant Output Voltage Difference (resistance during arbitration) $V_{\text{diff}} = V_{\text{CANH}} - V_{\text{CANL}}$	$V_{\text{diff_d_N}}$	1.5	–	5.0	V	⁴⁾ CAN Normal Mode; $V_{\text{TXDCAN}} = 0\text{V}$; $V_{\text{CAN}} = 5\text{V}$; $R_L = 2240\ \Omega$	P_9.3.51
CANH, CANL Dominant Output Voltage Difference (extended bus load range) $V_{\text{diff}} = V_{\text{CANH}} - V_{\text{CANL}}$	$V_{\text{diff_d_N}}$	1.4	–	3.3	V	⁴⁾ CAN Normal Mode; $V_{\text{TXDCAN}} = 0\text{V}$; $V_{\text{CAN}} = 5\text{V}$; $45\ \Omega \leq R_L \leq 70\ \Omega$	P_9.3.52
CANH, CANL output voltage difference slope, recessive to dominant	$V_{\text{diff_slope_rd}}$	–	–	70	V/us	⁴⁾ 30% to 70% of measured differential bus voltage, $C_L = 100\ \text{pF}$, $R_L = 60\ \Omega$	P_9.3.55

High-Speed CAN FD Transceiver

Table 18 Electrical Characteristics (cont'd)

$T_j = -40^\circ\text{C}$ to $+150^\circ\text{C}$; $V_S = 5.5\text{ V}$ to 28 V ; $V_{\text{CAN}} = 4.75\text{ V}$ to 5.25 V ; $R_L = 60\ \Omega$; CAN Normal Mode; all voltages with respect to ground, positive current flowing into pin (unless otherwise specified)

Parameter	Symbol	Values			Unit	Note or Test Condition	Number
		Min.	Typ.	Max.			
CANH, CANL output voltage difference slope, dominant to recessive	$V_{\text{diff_slope_dr}}$	–	–	70	V/us	⁴⁾ 70% to 30% of measured differential bus voltage, $C_L = 100\text{ pF}$, $R_L = 60\ \Omega$	P_9.3.56
Driver Symmetry $V_{\text{SYM}} = V_{\text{CANH}} + V_{\text{CANL}}$	V_{SYM}	4.5	–	5.5	V	²⁾ CAN Normal Mode; $V_{\text{TXDCAN}} = 0\text{ V} / 5\text{ V}$; $V_{\text{CAN}} = 5\text{ V}$; $C_{\text{SPLIT}} = 4.7\text{ nF}$; $50\ \Omega \leq R_L \leq 60\ \Omega$;	P_9.3.19
CANH Short Circuit Current (New ISO requirement)	I_{CANHsc}	-100	-80	-50	mA	CAN Normal Mode; $V_{\text{CANHshort}} = -3\text{ V}$; $V_{\text{CAN}} = 5\text{ V}$	P_9.3.20
CANL Short Circuit Current (New ISO requirement)	I_{CANLsc}	50	80	100	mA	CAN Normal Mode; $V_{\text{CANLshort}} = 18\text{ V}$; $V_{\text{CAN}} = 5\text{ V}$	P_9.3.21
Leakage Current	$I_{\text{CANH,Ik}}$ $I_{\text{CANL,Ik}}$	–	2	5	μA	$V_S = V_{\text{CAN}} = 0\text{ V}$; $0\text{ V} \leq V_{\text{CANH,L}} \leq 5\text{ V}$; ³⁾ $R_{\text{test}} = 0 / 47\text{ k}\Omega$	P_9.3.22

Receiver Output RXDCAN

High-level Output Voltage	$V_{\text{RXDCAN,H}}$	$0.8 \times V_{\text{CC1}}$	–	–	V	CAN Normal Mode; $I_{\text{RXDCAN}} = -2\text{ mA}$	P_9.3.23
Low-level Output Voltage	$V_{\text{RXDCAN,L}}$	–	–	$0.2 \times V_{\text{CC1}}$	V	CAN Normal Mode; $I_{\text{RXDCAN}} = 2\text{ mA}$	P_9.3.24

Transmission Input TXDCAN

High-level Input Voltage Threshold	$V_{\text{TXDCAN,H}}$	–	–	$0.7 \times V_{\text{CC1}}$	V	CAN Normal Mode; recessive state	P_9.3.25
Low-level Input Voltage Threshold	$V_{\text{TXDCAN,L}}$	$0.3 \times V_{\text{CC1}}$	–	–	V	CAN Normal Mode; dominant state	P_9.3.26
TXDCAN Input Hysteresis	$V_{\text{TXDCAN,hys}}$	$0.08 \times V_{\text{CC1}}$	$0.12 \times V_{\text{CC1}}$	$0.4 \times V_{\text{CC1}}$	mV	⁴⁾	P_9.3.27
TXDCAN Pull-up Resistance	R_{TXDCAN}	25	40	75	k Ω	–	P_9.3.28
CAN Transceiver Enabling Time	$t_{\text{CAN,EN}}$	8	12	18	μs	⁸⁾ CSN = High to first valid transmitted TXDCAN dominant	P_9.3.29

Dynamic CAN-Transceiver Characteristics

Min. Dominant Time for Bus Wake-up	t_{Wake1}	0.5	1.2	1.8	μs	$-12\text{ V} \leq V_{\text{CM}}(\text{CAN}) \leq 12\text{ V}$; CAN Wake Capable Mode	P_9.3.53
------------------------------------	--------------------	-----	-----	-----	---------------	---	----------

High-Speed CAN FD Transceiver

Table 18 Electrical Characteristics (cont'd)

$T_j = -40^\circ\text{C}$ to $+150^\circ\text{C}$; $V_S = 5.5\text{ V}$ to 28 V ; $V_{\text{CAN}} = 4.75\text{ V}$ to 5.25 V ; $R_L = 60\ \Omega$; CAN Normal Mode; all voltages with respect to ground, positive current flowing into pin (unless otherwise specified)

Parameter	Symbol	Values			Unit	Note or Test Condition	Number
		Min.	Typ.	Max.			
Wake-up Time-out, Recessive Bus	$t_{\text{Wake}2}$	0.8	–	10	ms	⁸⁾ CAN Wake Capable Mode	P_9.3.31
Wake-up reaction time (WUP or WUF)	$t_{\text{WU_WUP/WUF}}$	–	–	100	μs	⁸⁾⁵⁾⁶⁾ Wake-up reaction time after a valid WUP or WUF;	P_9.3.54
Loop delay (recessive to dominant)	$t_{\text{LOOP},f}$	–	150	255	ns	²⁾ CAN Normal Mode; $C_L = 100\text{pF}$; $R_L = 60\ \Omega$; $V_{\text{CAN}} = 5\text{V}$; $C_{\text{RXDCAN}} = 15\text{ pF}$	P_9.3.32
Loop delay (dominant to recessive)	$t_{\text{LOOP},r}$	–	150	255	ns	²⁾ CAN Normal Mode; $C_L = 100\text{pF}$; $R_L = 60\ \Omega$; $V_{\text{CAN}} = 5\text{V}$; $C_{\text{RXDCAN}} = 15\text{ pF}$	P_9.3.33
Propagation Delay TXDCAN Low to bus dominant	$t_{d(L),T}$	–	90	140	ns	CAN Normal Mode; $C_L = 100\text{pF}$; $R_L = 60\ \Omega$; $V_{\text{CAN}} = 5\text{V}$	P_9.3.34
Propagation Delay TXDCAN High to bus recessive	$t_{d(H),T}$	–	100	140	ns	CAN Normal Mode; $C_L = 100\text{pF}$; $R_L = 60\ \Omega$; $V_{\text{CAN}} = 5\text{V}$	P_9.3.35
Propagation Delay bus dominant to RXDCAN Low	$t_{d(L),R}$	–	100	–	ns	CAN Normal Mode; $C_L = 100\text{pF}$; $R_L = 60\ \Omega$; $V_{\text{CAN}} = 5\text{V}$; $C_{\text{RXDCAN}} = 15\text{ pF}$	P_9.3.36
Propagation Delay bus recessive to RXDCAN High	$t_{d(H),R}$	–	100	–	ns	CAN Normal Mode; $C_L = 100\text{pF}$; $R_L = 60\ \Omega$; $V_{\text{CAN}} = 5\text{V}$; $C_{\text{RXDCAN}} = 15\text{ pF}$	P_9.3.37

High-Speed CAN FD Transceiver

Table 18 Electrical Characteristics (cont'd)

$T_j = -40^{\circ}\text{C}$ to $+150^{\circ}\text{C}$; $V_S = 5.5\text{ V}$ to 28 V ; $V_{\text{CAN}} = 4.75\text{ V}$ to 5.25 V ; $R_L = 60\ \Omega$; CAN Normal Mode; all voltages with respect to ground, positive current flowing into pin (unless otherwise specified)

Parameter	Symbol	Values			Unit	Note or Test Condition	Number
		Min.	Typ.	Max.			
Received Recessive bit width (CAN FD up to 2Mbps)	$t_{\text{bit(RXD)}}$	400	–	550	ns	CAN Normal Mode; $C_L = 100\text{pF}$; $R_L = 60\ \Omega$; $V_{\text{CAN}} = 5\text{V}$; $C_{\text{RXD}} = 15\text{pF}$; $t_{\text{bit(TXD)}} = 500\text{ns}$; Parameter definition in according to Figure 24 .	P_9.3.38
Transmitted Recessive bit width (CAN FD up to 2Mbps)	$t_{\text{bit(BUS)}}$	435	–	530	ns	CAN Normal Mode; $C_L = 100\text{pF}$; $R_L = 60\ \Omega$; $V_{\text{CAN}} = 5\text{ V}$; $C_{\text{RXD}} = 15\text{ pF}$; $t_{\text{bit(TXD)}} = 500\text{ns}$; Parameter definition in according to Figure 24 .	P_9.3.43
Receiver timing symmetry (CAN FD up to 2Mbps)	Δt_{Rec}	-65	–	40	ns	⁷⁾ CAN Normal Mode; $C_L = 100\text{pF}$; $R_L = 60\ \Omega$; $V_{\text{CAN}} = 5\text{V}$; $C_{\text{RXD}} = 15\text{pF}$; $t_{\text{bit(TXD)}} = 500\text{ns}$; Parameter definition in according to Figure 24 .	P_9.3.44
Received Recessive bit width (CAN FD up to 5Mbps)	$t_{\text{bit(RXD)}}$	120	–	220	ns	CAN Normal Mode; $C_L = 100\text{pF}$; $R_L = 60\ \Omega$; $V_{\text{CAN}} = 5\text{V}$; $C_{\text{RXD}} = 15\text{pF}$; $t_{\text{bit(TXD)}} = 200\text{ns}$; Parameter definition in according to Figure 24 .	P_9.3.45

High-Speed CAN FD Transceiver

Table 18 Electrical Characteristics (cont'd)

$T_j = -40^\circ\text{C}$ to $+150^\circ\text{C}$; $V_S = 5.5\text{ V}$ to 28 V ; $V_{\text{CAN}} = 4.75\text{ V}$ to 5.25 V ; $R_L = 60\ \Omega$; CAN Normal Mode; all voltages with respect to ground, positive current flowing into pin (unless otherwise specified)

Parameter	Symbol	Values			Unit	Note or Test Condition	Number
		Min.	Typ.	Max.			
Transmitted Recessive bit width (CAN FD up to 5Mbps)	$t_{\text{bit(BUS)}}$	155	–	210	ns	CAN Normal Mode; $C_L = 100\text{pF}$; $R_L = 60\ \Omega$; $V_{\text{CAN}} = 5\text{ V}$; $C_{\text{RXD}} = 15\text{ pF}$; $t_{\text{bit(TXD)}} = 200\text{ns}$; Parameter definition in according to Figure 24 .	P_9.3.46
Receiver timing symmetry (CAN FD up to 5Mbps)	Δt_{Rec}	-45	–	15	ns	CAN Normal Mode; $C_L = 100\text{pF}$; $R_L = 60\ \Omega$; $V_{\text{CAN}} = 5\text{V}$; $C_{\text{RXD}} = 15\text{pF}$; $t_{\text{bit(TXD)}} = 200\text{ns}$; Parameter definition in according to Figure 24 .	P_9.3.47
TXDCAN Permanent Dominant Time-out	$t_{\text{TXDCAN_TO}}$	1.6	2.0	2.4	ms	⁸⁾ CAN Normal Mode	P_9.3.39
BUS Permanent Dominant Time-out	$t_{\text{BUS_CAN_TO}}$	2.0	2.5	3.0	ms	⁸⁾ CAN Normal Mode	P_9.3.40
Timeout for bus inactivity	t_{SILENCE}	0.6	–	1.2	s	⁸⁾	P_9.3.48
Bus Bias reaction time	t_{Bias}	–	–	250	μs	⁸⁾	P_9.3.49

- 1) Not subject to production test, specified by design, S2P - Method; $f = 10\text{ MHz}$.
- 2) V_{SYM} shall be observed during dominant and recessive state and also during the transition dominant to recessive and vice versa while TXD is simulated by a square signal (50% duty cycle) with a frequency of up to 1 MHz (2 MBit/s);
- 3) R_{test} between (V_S / V_{CAN}) and 0V (GND).
- 4) Not subject to production test, specified by design.
- 5) Wake-up is signaled via INTN pin activation in SBC Stop Mode and via VCC1 ramping up with wake from SBC Sleep Mode.
- 6) For WUP: time starts with end of last dominant phase of WUP; for WUF: time starts with end of CRC delimiter of the WUF.
- 7) $\Delta t_{\text{Rec}} = t_{\text{bit(RXD)}} - t_{\text{bit(BUS)}}$.
- 8) Not subject to production test, tolerance defined by internal oscillator tolerance.

High-Speed CAN FD Transceiver

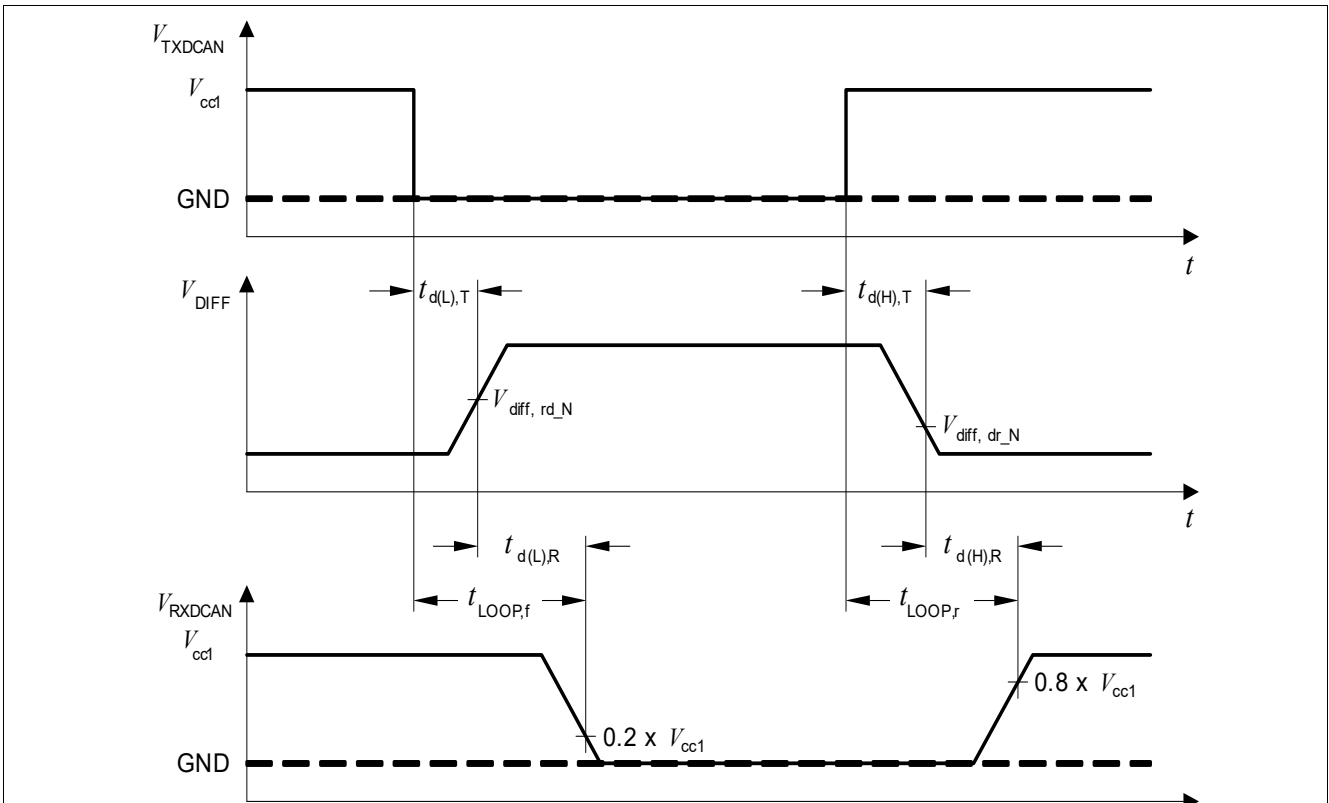

Figure 23 Timing Diagrams for Dynamic Characteristics

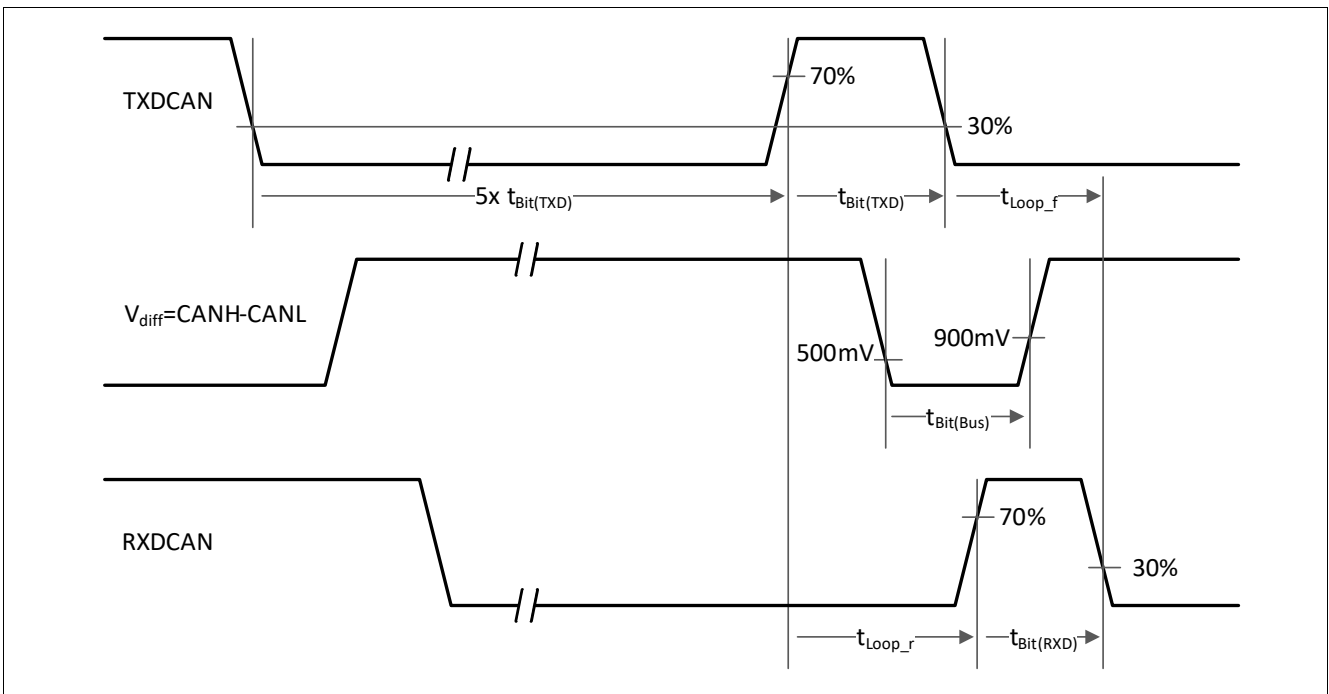

Figure 24 From ISO 11898-2: tloop, tbit(TXD), tbit(Bus), tbit(RXD) definitions

9 High-Voltage Wake and Voltage Monitoring Input

9.1 Block Description

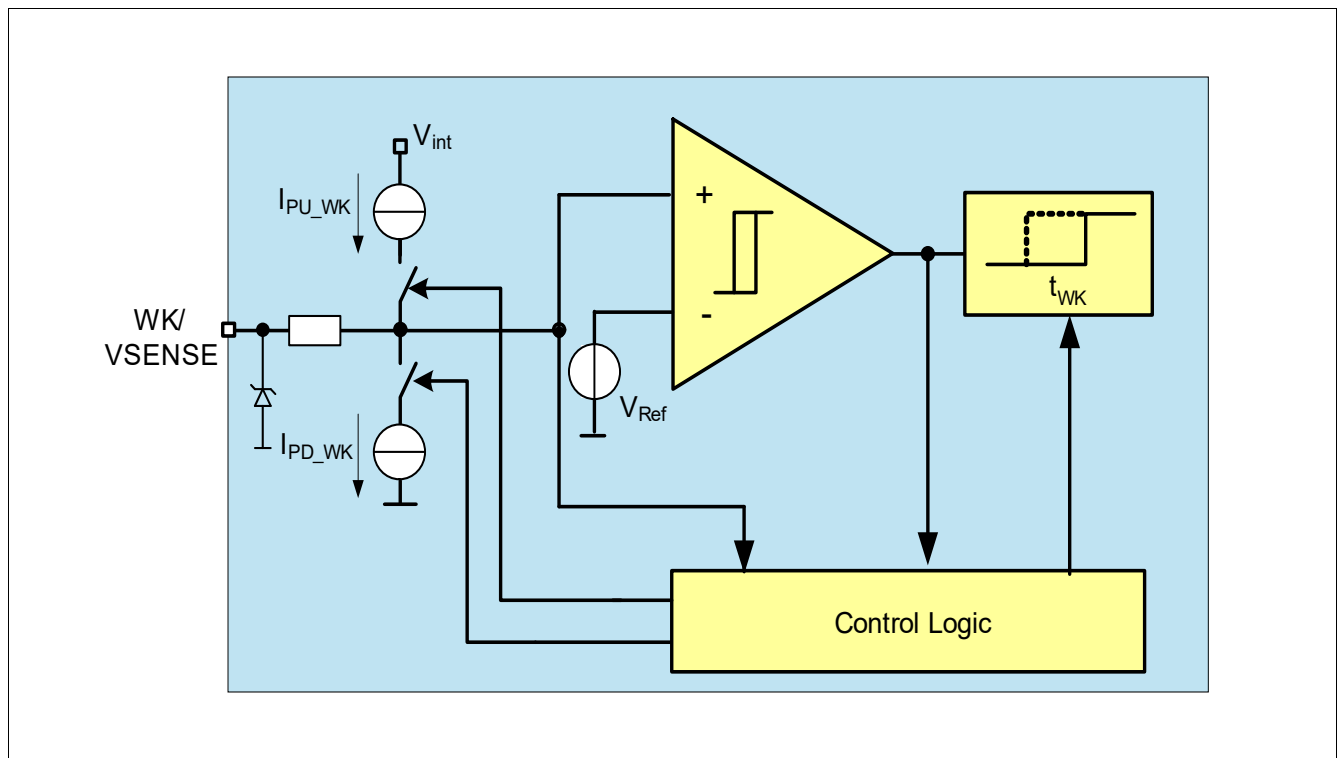

Figure 25 Wake Input Block Diagram

Features

- High-Voltage input with a 3V (typ.) threshold voltage
- Alternate measurement feature for high-voltage sensing via pins WK/SENSE and FO/GPIO
- Wake-up capability for power saving modes
- Edge sensitive wake-up feature Low to High and High to Low
- Pull-up and Pull-down current sources, configurable via SPI
- Selectable configuration for Static Sense or cyclic sense working with TIMER
- In SBC Normal and SBC Stop Mode the level of the WK pin can be read via SPI

9.2 High-Voltage Wake Function

9.2.1 Functional Description

The wake input pin is edge-sensitive inputs with a switching threshold of typically 3V. Both transitions, High to Low and Low to High, result in a signalization by the SBC. The signalization occurs either by triggering the interrupt in SBC Normal Mode and SBC Stop Mode or by a wake-up of the device in SBC Sleep and SBC Fail-Safe Mode.

Two different wake-up detection modes can be selected via SPI:

- Static Sense: WK inputs are always active
- Cyclic Sense: WK inputs are only active for a certain time period (see [Chapter 5.2.1](#))

A filter time of 16 μ s is implemented to avoid an unintentional wake-up due to transients or EMI disturbances in Static Sense configuration.

The filter time (t_{FWK1}) is triggered by a level change crossing the switching threshold and a wake signal is recognized if the input level does not cross again the threshold during the selected filter time.

Figure 26 shows a typical wake-up timing and filtering of transient pulses.

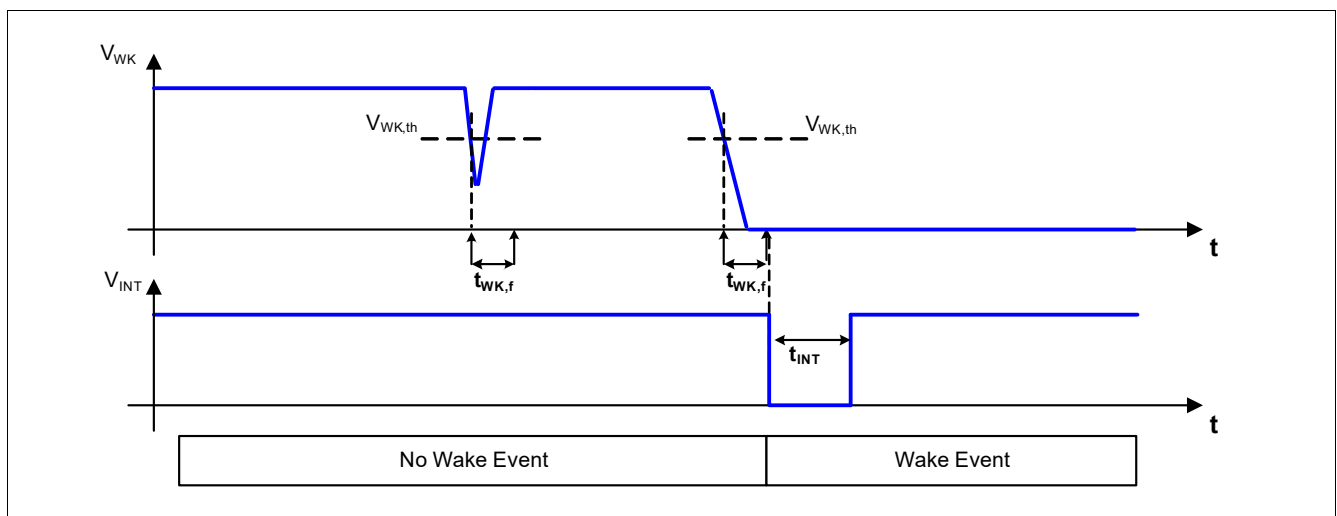

Figure 26 Wake-up Filter Timing for Static Sense

The wake-up capability of the WK pin can be enabled or disabled via SPI command in the **WK_CTRL_1** register.

A wake-up event via the WK pin can always be read in the register **WK_STAT_0** at the bit **WK_WU**.

The actual voltage level of the WK pin (Low or High) can always be read in SBC Normal and SBC Stop-, and Init Mode in the register **WK_LVL_STAT**. During Cyclic Sense, the register shows the sampled levels of the respective WK pin.

If FO/GPIO is configured as WK input in its alternative function (16 μ s static filter time), then the wake-up events are signalled in the register **WK_STAT_1**.

High-Voltage Wake and Voltage Monitoring Input

9.2.2 Wake Input Configuration

To ensure a defined and stable voltage levels at the internal comparator input it is possible to configure integrated current sources via the SPI register **WK_PUPD_CTRL**. An example illustration for the automatic switching configuration is shown in **Figure 27**.

Table 19 Pull-Up / Pull-Down Resistor

WKx_PUPD_1	WKx_PUPD_0	Current Sources	Note
0	0	no current source	WK input is floating if left open (default setting)
0	1	pull-down	WK input internally pulled to GND
1	0	pull-up	WK input internally pulled to internal 5V supply
1	1	Automatic switching	If a High level is detected at the WK input the pull-up source is activated, if Low level is detected the pull down is activated.

Note: If there is no pull-up or pull-down configured on the WK input, then the respective input should be tied to GND or VS on board to avoid unintended floating of the pin and subsequent wake-up events.

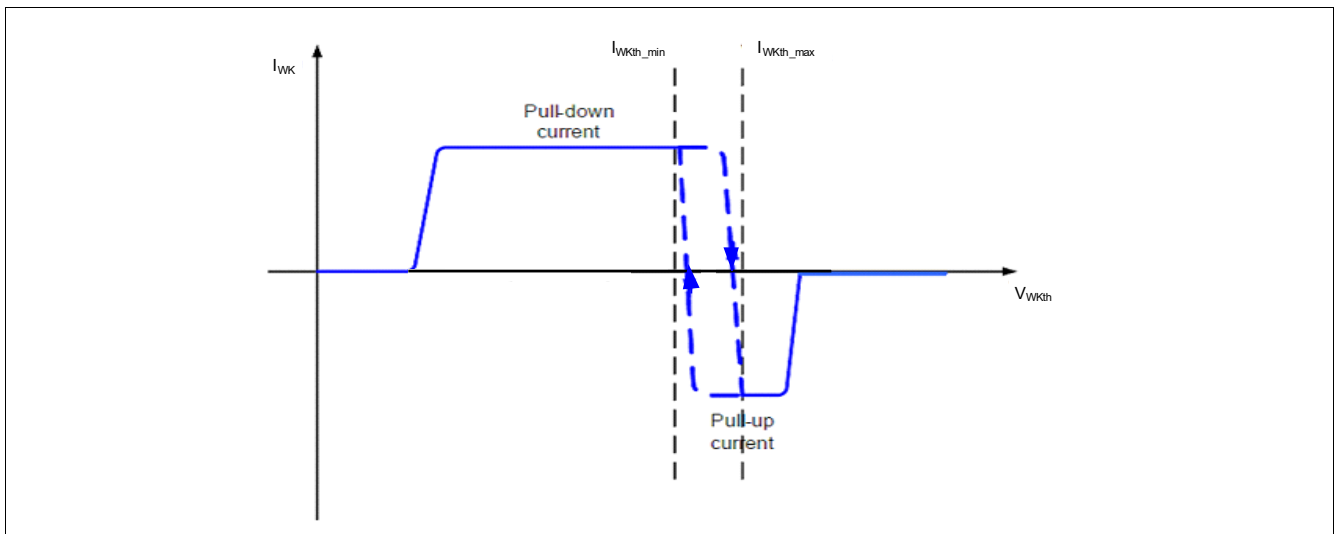

Figure 27 Illustration for Pull-Up / Down Current Sources with Automatic Switching Configuration

High-Voltage Wake and Voltage Monitoring Input

9.2.3 Wake configuration for Cyclic Sense

The wake input pin can also be used for cyclical sensing of monitoring signals during low-power modes. For this function the WK input performs a cyclic sensing of the voltage level during the On-time of the GPIO HS.

A transition of the voltage level triggers a wake-up event.

In order to enable this functionality the GPIO must be configured as HS to be controlled by the Timer.

See also [Chapter 5.2.1](#) and [Chapter 11.1.2](#) for more details.

9.2.4 High-Voltage Sensing as Alternate Function

This function provides the possibility to measure a voltage, e.g. the unbuffered battery voltage, with the protected WK HV-input pin. The measured voltage is routed out at FO/GPIO.

If this function is enabled with the **WK_MEAS** then neither the FO (including the FO test via **FO_ON**), nor the GPIO functionality nor the WK functionality are available.

If the measurement function is enabled then following items should be noted:

- The internal pull-up / pull-down structures are disabled and the internal WK signal is gated (blocked)
- The settings for WK in the registers **WK_PUPD_CTRL** and **WK_CTRL_1** are ignored (but changing the settings is not prevented)
- The wake capability and voltage monitoring of the WK pin is disabled, i.e. **WK_STAT_0** and **WK_LVL_STAT** are not updated, i.e. the bits in **WK_LVL_STAT** are cleared
- If WK is the only valid wake source then the **SPI_FAIL** flag is set when trying to enter SBC Sleep Mode (see also [Chapter 5.1](#)) and SBC Restart Mode is entered

Please refer to [Chapter 5.4](#) for more details on the functionality of the measurement unit.

High-Voltage Wake and Voltage Monitoring Input

9.3 Electrical Characteristics

Table 20 Electrical Characteristics

$V_S = 5.5\text{ V to }28\text{ V}$; $T_j = -40^\circ\text{C to }+150^\circ\text{C}$; all voltages with respect to ground, positive current flowing into pin (unless otherwise specified)

Parameter	Symbol	Values			Unit	Note or Test Condition	Number
		Min.	Typ.	Max.			
WK Input Pin Characteristics							
Wake-up/monitoring threshold voltage	V_{WKth}	2	3	4	V	without external serial resistor R_S (with R_S : $\Delta V = I_{PD/PU} \times R_S$); hysteresis included	P_10.3.1
Threshold hysteresis	$V_{WKNth,hys}$	0.1	-	0.7	V	without external serial resistor R_S (with R_S : $\Delta V = I_{PD/PU} \times R_S$)	P_10.3.2
WK pin Pull-up Current	I_{PU_WK}	-20	-10	-3	μA	$V_{WK_IN} = 4\text{V}$	P_10.3.3
WK pin Pull-down Current	I_{PD_WK}	3	10	20	μA	$V_{WK_IN} = 2\text{V}$	P_10.3.4
Input leakage current	$I_{LK,I}$	-2		2	μA	$0\text{ V} < V_{WK_IN} < 40\text{V}$	P_10.3.5
Timing							
Wake-up filter time 1	t_{FWK1}	13	16	20	μs	¹⁾	P_10.3.6

1) Not subject to production test, tolerance defined by internal oscillator tolerance

Interrupt Function

10 Interrupt Function

10.1 Block and Functional Description

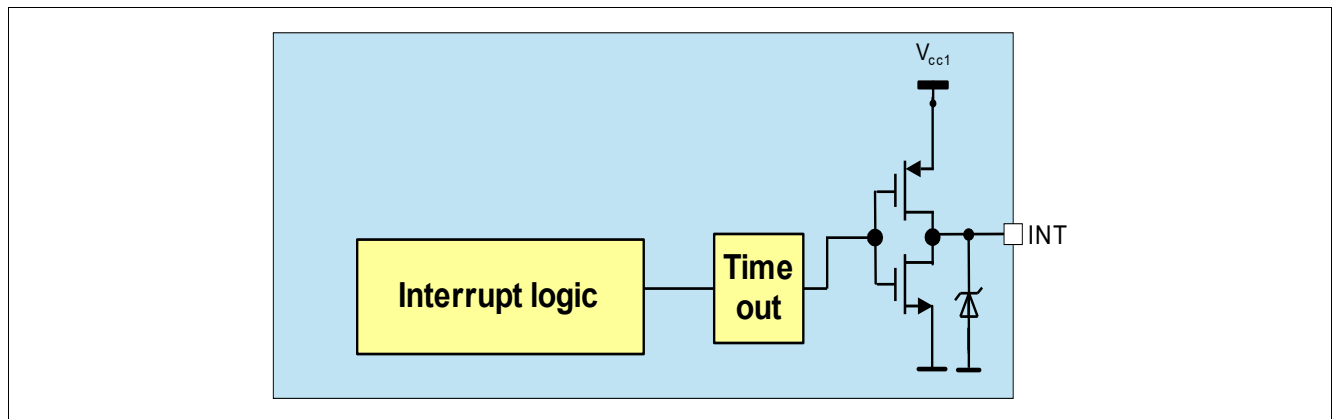

Figure 28 Interrupt Block Diagram

The interrupt is used to signalize special events in real time to the microcontroller. The interrupt block is designed as a push/pull output stage as shown in [Figure 28](#). An interrupt is triggered and the INTN pin is pulled Low (active Low) for t_{INTN} in SBC Normal and Stop Mode and it is released once t_{INTN} is expired. The minimum High-time of INTN between two consecutive interrupts is t_{INTND} . An interrupt does not cause a SBC mode change.

Two different interrupt classes could be selected via the SPI bit **INT_GLOBAL**:

- Class 1 (wake interrupt - **INT_GLOBAL**=0): all wake-up events stored in the wake status SPI registers (**WK_STAT_0** and **WK_STAT_1** if GPIO is configured as WK) cause an interrupt. The wake sources are listed below.
An interrupt is only triggered if the respective function is also enabled as a wake source (including GPIOx if configured as a wake input).
 - via CAN (wake-up)
 - via the WK pin
 - via TIMER
 - via GPIO (if configured as WK input)
- Class 2 (global interrupt - **INT_GLOBAL**=1): in addition to the wake-up events, all signalled failures stored in the other status registers trigger an interrupt (the registers **WK_LVL_STAT** and **FAM_PROD_STAT** are not generating interrupts)

Note: The errors that cause SBC Restart or SBC Fail-Safe Mode (**VCC1_UV**, **WD_FAIL**, **VCC1_SC**, **TSD2_SAFE**, **TSD2**, **FAILURE**) are the exceptions of an INTN generation on status bits. Also the bits **POR** and **DEV_STAT_[1:0]** will not generate interrupts.

Note: During SBC Restart Mode the SPI is blocked and the microcontroller is in reset. Therefore the INTN is not activated in SBC Restart Mode, which is the same behavior in SBC-Fail-Safe or Sleep Mode.

Interrupt Function

In addition to this behavior, INTN is triggered when SBC Stop Mode is entered and not all wake source bits were cleared in the **WK_STAT_0** and **WK_STAT_1** register.

The SPI status registers are updated at every falling edge of the INTN pulse. All interrupt events are stored in the respective register (except the register **WK_LVL_STAT**) until the register is read and cleared via SPI command. A second SPI read after reading out the respective status register is optional but recommended to verify that the interrupt event is not present anymore. The interrupt behavior is shown in **Figure 29** for class 1 interrupts. The behavior for class 2 is identical.

The INTN pin is also used during SBC Init Mode to select the hardware configuration of the device. See **Chapter 5.1.1** for further information.

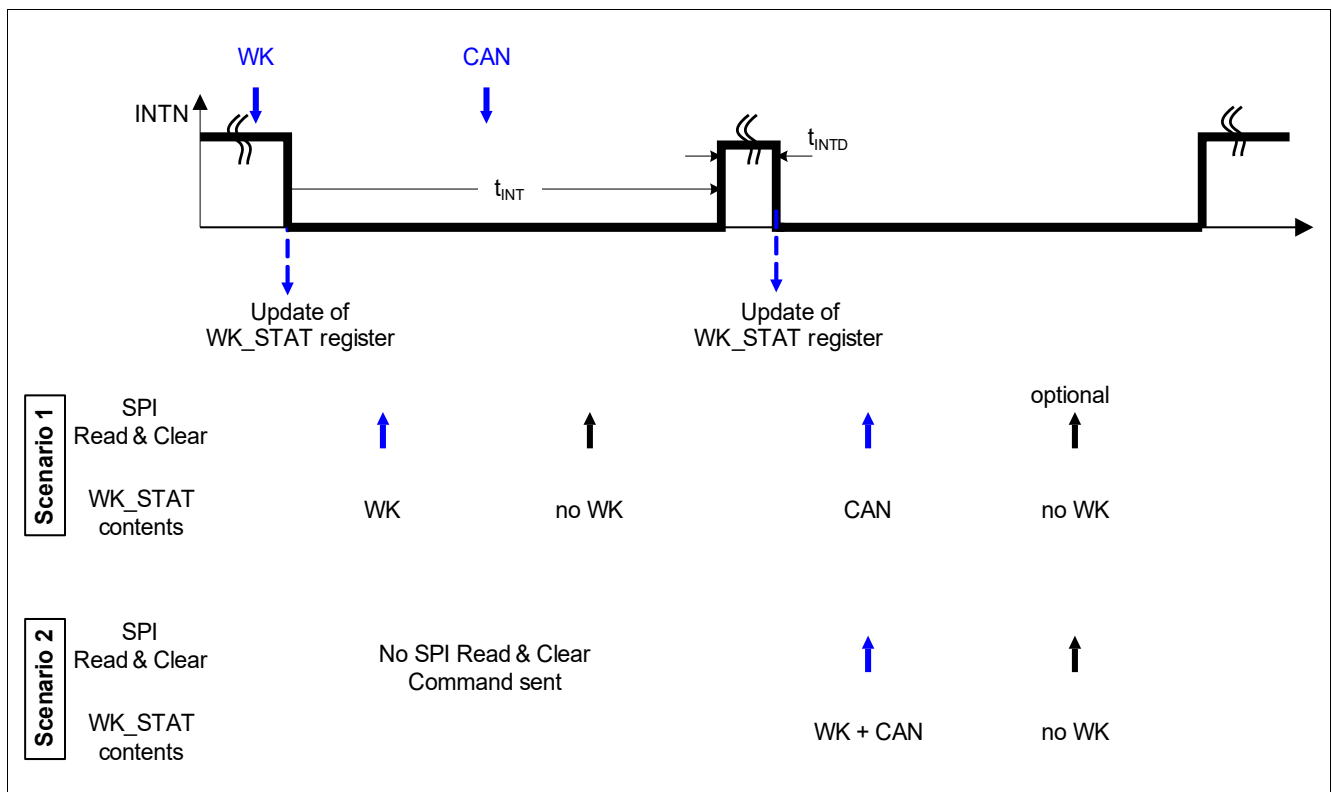

Figure 29 Interrupt Signalization Behavior

Interrupt Function

10.2 Electrical Characteristics

Table 21 Electrical Characteristics

$V_S = 5.5\text{ V to }28\text{ V}$; $T_j = -40^\circ\text{C to }+150^\circ\text{C}$; SBC Normal Mode; all voltages with respect to ground; positive current defined flowing into pin (unless otherwise specified)

Parameter	Symbol	Values			Unit	Note or Test Condition	Number
		Min.	Typ.	Max.			
Interrupt Output; Pin INTN							
INTN High Output Voltage	$V_{\text{INTN,H}}$	$0.8 \times V_{\text{CC1}}$	–	–	V	¹⁾ $I_{\text{INTN}} = -1\text{ mA}$; INTN = Off	P_11.2.1
INTN Low Output Voltage	$V_{\text{INTN,L}}$	–	–	$0.2 \times V_{\text{CC1}}$	V	¹⁾ $I_{\text{INTN}} = 1\text{ mA}$; INTN = On	P_11.2.2
INTN Pulse Width	t_{INTN}	80	100	120	μs	²⁾	P_11.2.3
INTN Pulse Minimum Delay Time	t_{INTND}	80	100	120	μs	²⁾ between consecutive pulses	P_11.2.4
Configuration Select; Pin INTN							
Config Pull-down Resistance	R_{CFG}	150	250	320	$\text{k}\Omega$	$V_{\text{INTN}} = 5\text{ V}$	P_11.2.5
Config Select Filter Time	t_{CFG_F}	5	10	14	μs	²⁾	P_11.2.6

1) Output Voltage Value also determines device configuration during SBC Init Mode

2) Not subject to production test, tolerance defined by internal oscillator tolerance.

11 Fail Output (FO) and General Purpose I/O (GPIO)

11.1 Block and Functional Description

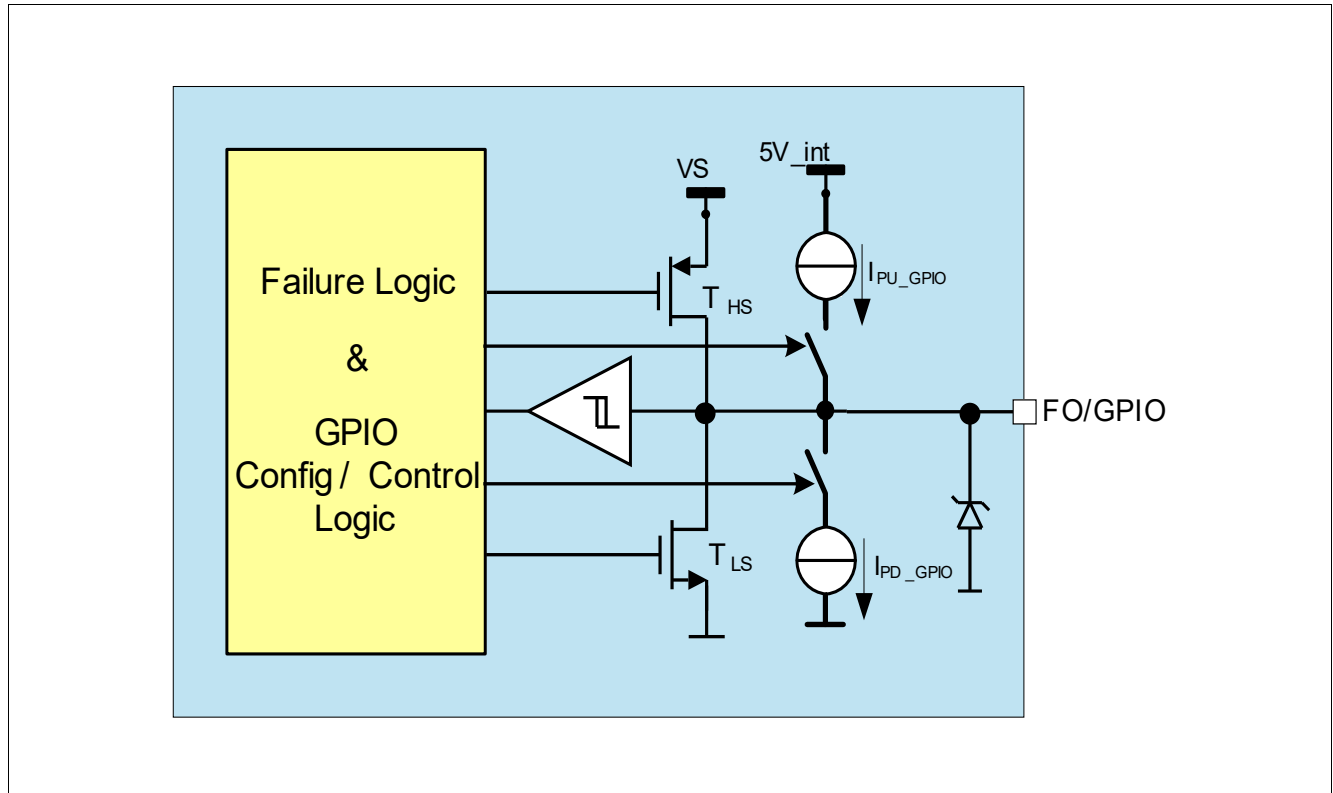

Figure 30 Simplified Fail Output and GPIO Block Diagram

Features

- Fail-Output Function to signalize fail-safe events (FO function)
- General Purpose I/O functionality in case the fail-output function is not needed (GPIO function)
- Output of HV Measurement function in case WK/SENSE is selected accordingly ([WK_MEAS](#))

Fail Output (FO) and General Purpose I/O (GPIO)

11.1.1 Fail-Output Function

The fail output consists of a failure logic and an open-drain output (FO) with active-low signalization. It is the default configuration after device power-up to support fail-safe functions.

The fail output is activated due to following failure conditions:

- Watchdog trigger failure (For config 3&4 only after the 2nd watchdog trigger failure and for config 1&2 after 1st watchdog trigger failure)
- Thermal shutdown TSD2
- VCC1 short to GND
- VCC1 over voltage (only if the SPI bit **VCC1_OV_RST** is set)

If FO is triggered, the SBC Fail-Safe Mode is entered (exceptions are watchdog trigger failures depending on selected configurations - see [Chapter 5.1.1](#)). The fail output activation is signalled in the SPI bit **FAILURE** of the register **DEV_STAT**.

The entry of SBC Fail-Safe Mode due to a watchdog failure can be configured as described in [Chapter 5.1.1](#). If the FO was activated due to a failure then it stays activated (pulled Low) in all SBC Modes.

In order to deactivate the fail output in SBC Normal Mode the failure conditions must not be present anymore (e.g. TSD2, VCC1 short circuit, VCC1 over voltage - independent of the **VCC1_OV_RST**, etc) and the bit **FAILURE** must be cleared via SPI command. In case of a **FAILURE** bit is set due to a watchdog fail, a successful WD trigger is needed in addition, i.e. **WD_FAIL** must be cleared. **WD_FAIL** is also cleared when going to SBC Sleep or SBC Fail-Safe Mode due to another failure (not a WD failure) or if the watchdog is disabled in SBC Stop Mode.

For testing purposes only the Fail Output can be activated via SPI by setting the bit **FO_ON**. This bit is independent of the FO failure bits. In case there is no failure condition, the FO output can also be turned Off again via SPI, i.e. no successful watchdog trigger is needed.

In case FO was activated via the SPI bit **FO_ON** it is disabled when entering SBC Restart Mode and stays Off in SBC Normal Mode.

Note: The Fail output pin is triggered for any of the above described failures.

*Note: The bit **FO_ON** can be written in any GPIO configuration. However, the fail-output pin FO/GPIO is only activated if GPIO is configured as FO, i.e. the bit is ignored for any other GPIO configuration.*

Fail Output (FO) and General Purpose I/O (GPIO)

11.1.2 General Purpose I/O Function as Alternative Function

In case the FO functionality is not used, the pin can be configured with an alternative function as high-voltage (VS related) General Purpose I/O pin via the SPI bits **GPIO**.

To avoid unintentional changes of the respective GPIO function during operation the configuration can be locked via the SPI bit **CFG_LOCK_0**

FO/GPIO can be reconfigured in SBC Normal Mode for the following functions:

- FO functionality (default state) when configured as GPIO = '000'...'010':
 - Overcurrent shutdown and open load detection is disabled
- Off (also disabled in case FO1 is activated) when configured as GPIO = '100'
- Wake Input when configured as GPIO = '101':
 - There is a blanking time $t_{\text{GPIO,WK,blank}}$ when FO/GPIO is configured as wake input. Only then the level detection becomes valid, i.e. the filter time t_{FWK1} is started.
 - The pin can be used as a wake source. A level change is detected at the threshold $V_{\text{GPIOI,th}}$. The wake capability can be enabled and disabled by setting the **GPIO** bits. Once configured as wake input it is automatically wake capable.
 - wake-up events are stored and reported in **WK_STAT_1**; the bit **GPIO_WK_WU** is cleared when SBC Fail-Safe Mode is entered.
 - Internal pull-up or pull-down structures are implemented and can be configured with the SPI bits **GPIO_WK_PUPD**.
 - SBC Normal, Stop-, Init and Restart Mode: The input level is shown in the **WK_LVL_STAT** register
 - SBC Normal and Stop Mode: INTN is triggered in case of a qualified edge change.
 - SBC Restart Mode: The SPI is blocked and cannot be read; INTN is not triggered but **GPIO_WK_WU** is set.
 - SBC Sleep Mode: The device is woken in case of a qualified edge change, i.e. VCC1 is enabled. **WK_LVL_STAT** is updated during SBC Sleep and Fail-Safe Mode but it can only be read when entering SBC Normal Mode again.
- Low-Side incl. PWM control when configured as GPIO = '110':
 - The switch is controlled by the PWM generator: 0% DC = Off and 100% DC = On; any other duty cycle can be configured in **PWM_CTRL**.

The PWM frequency can be selected in **PWM_FREQ_CTRL**

- The respective level at the pin is shown in **WK_LVL_STAT** in SBC Normal, Stop-, Init and Restart Mode and can serve as a feedback about the respective switch state¹⁾
 - On-state overcurrent shutdown is implemented.
In PWM operation the diagnosis is active only during the LS On-time.
The bit **GPIO_OC** shows an over current shutdown respectively and the switch is disabled.
Depending on the duty cycle the diagnosis might not be activated considering the respective filter timing.
- High-Side incl. PWM control when configured as GPIO = '111':

1) The level is determined by the wake comparator and is shown as Low or High, i.e. the feature might not be useful if a duty cycle of $0\% < DC < 100\%$ is applied

Fail Output (FO) and General Purpose I/O (GPIO)

- The switch is controlled by the PWM generator: 0% DC = Off and 100% DC = On; any other duty cycle can be configured in **PWM_CTRL**.

The PWM frequency can be selected in **PWM_FREQ_CTRL**

- The respective level at the pin is shown in **WK_LVL_STAT** in SBC Normal, Stop-, Init and Restart Mode and can serve as a feedback about the respective switch state¹⁾
- On-state open load detection and overcurrent shutdown is implemented. During PWM operation the diagnosis is active only during the HS On-time. In case of open load detection the bit **GPIO_OL** is set. In case of over current detection the bit **GPIO_OC** is set and the switch is shut down. Depending on the duty cycle the diagnosis might not be activated considering the respective filter time
- High-Side with Cyclic Sense functionality when configured as GPIO = '011':
 - The HS is used in combination with the WK pin and is controlled by the Timer. Cyclic Sense does not work if the GPIO is not configured accordingly.
 - The configuration for Cyclic Sense, e.g. the period and On-time of the Cyclic Sense function is done via the registers **TIMER_CTRL**, **WK_CTRL_1**, **WK_PUPD_CTRL**
 - A learning cycle is always started if the timer is started via the On-time and GPIO is configured as HS with Cyclic Sense = '011'
 - Overcurrent shutdown is active only during the HS On-time: In case of over current detection the bit **GPIO_OC** is set and the switch is shut down. The timer keeps running, i.e. Cyclic Wake is still available. The open load detection is not available in this configuration.
 - **WK_LVL_STAT** is not updated
 - See **Chapter 5.2.1** and **Chapter 9.2** for more information about Cyclic Sense

*Note: It must be ensured that the correct GPIO configuration is selected after device power-up to ensure proper functionality.
It is recommended to use the **CFG_LOCK_0** bit to avoid unintentional configuration changes.
It is not recommended to change the GPIO configuration during the operation to avoid misleading SPI status bit settings (e.g. wake-up event, over current, open load) or unexpected timings due to shared PWM generator.*

*Note: Before GPIO is be configured as HS or LS with PWM Control the **PWM_CTRL** register must be set .*

*Note: The internally stored default value used for the wake-input configuration is 'Low'. A level change is signaled via the bit **GPIO_WK_WU** in case the externally connected signal on FO/GPIO is 'High'. If there is a level change at the FO/GPIO pin while configuring the wake function then a wake-up event can occur as there is no internal learning cycle and the last filtered value is used as a reference.*

Shutdown behavior in case of low-side or high-side configuration (incl. Cyclic Sense & PWM):

- The switch is disabled in case of over current detection with low- or high-side configuration, SBC Restart or Fail-Safe Mode entry
- The SPI bits are set to **GPIO** = Off = '100'
- The switch stays Off until it is enabled again via the **GPIO** bits,
- In case **CFG_LOCK_0** is set, then the bit must first be cleared before the configuration can be enabled again. Then the lock bit should be set again
- The switch can be enabled even if **GPIO_OL** or **GPIO_OC** bit is set.

Fail Output (FO) and General Purpose I/O (GPIO)

- A **VS_UV** condition is not affecting the behavior of the GPIO.

Note: After a short-circuit event for either low-side or high-side configuration a minimum recovery time of 25us must be ensured before enabling the respective function again!

*Note: If FO is not enabled then FO/GPIO is also not activated in case of failures. Also the **FAILURE** bit is set but it can be cleared. In addition, it is not possible to activate FO/GPIO via **FO_ON** in this case.*

Restart and Soft-Reset Behavior:

The behavior during SBC Restart and Fail-Safe Mode as well as the transition to SBC Normal Mode is as follows:

- if configured as Wake Input: it will stay wake capable during SBC Restart Mode and is an automatic wake source in SBC Fail-Safe Mode. **WK_LVL_STAT** is updated but it can only be read when entering again SBC Normal Mode.
- if configured as Low-Side or High-Side: The switch is disabled during SBC Restart and Fail-Safe Mode. They stay Off when returning to SBC Normal Mode and can be enabled again via SPI (Restart value is 'Off').
- if configured as FO and activated due to a failure: FO stays activated during SBC Restart Mode and when entering SBC Normal Mode (SPI register is not modified).
- In case of a SBC Soft Reset command the GPIO configuration remains unchanged if **CFG_LOCK_0** is set but the settings for Timer and PWM register are reset.

The detailed behavior for the respective configurations and SBC modes is listed in below table:

Table 22 Fail-Output and GPIO configuration behavior during the respective SBC Modes

FO Configuration	SBC Normal Mode	SBC Stop Mode	SBC Sleep Mode	SBC Restart Mode	SBC Fail-Safe Mode
FO (default)	configurable	fixed	fixed	active / fixed	active
Off		Off	Off	Off	Off
Wake Input		wake capable	wake capable	wake capable	wake capable
Low-Side		fixed	fixed	Off	Off
High-Side		fixed	fixed	Off	Off

Note: Above mentioned behavior also applies to the PWM operation for LS and HS and for HS Cyclic Sense function.

Explanation of GPIO states:

- configurable: settings can be changed in this SBC mode
- fixed: settings stay as configured in SBC Normal Mode
- active: FO is activated due to a failure leading to SBC Restart or Fail-Safe Mode.

11.1.3 WK and FO/GPIO HV-Sensing Function as Alternative Function

This function provides the possibility to measure a voltage, e.g. the unbuffered battery voltage, with the protected WK HV-input. The measured voltage is routed out at FO/GPIO.

If this function is enabled with the **WK_MEAS** then neither the FO (including the FO test via **FO_ON**) nor the GPIO functionality is available. Trying to enable the FO/GPIO functionality sets the **SPI_FAIL** flag.

If the measurement function is enabled the following items must be noted:

- The internal pull-up / pull-down structures are disabled and the internal WK signal is gated (blocked)
- The register **WK_PUPD_CTRL** can be modified but functionality changes are ignored. The **GPIO_CTRL** cannot be modified while **WK_MEAS** = '1'. **WK_MEAS** cannot be set if FO is configured. In this case **SPI_FAIL** is set.
FO must be set to Off first.
- The wake capability and voltage monitoring of the WK pin is disabled, i.e. **WK_STAT_1** and **WK_LVL_STAT** are not updated
- If GPIO WK is the only valid wake source then the **SPI_FAIL** flag is set when trying to enter SBC Sleep Mode (see also **Chapter 5.1**) and SBC Restart Mode is entered

Please refer to **Chapter 5.4** for more details on the functionality of the measurement unit.

Fail Output (FO) and General Purpose I/O (GPIO)

11.2 Electrical Characteristics

Table 23 Electrical Characteristics

$V_S = 5.5\text{ V to }28\text{ V}$; $T_j = -40^\circ\text{C to }+150^\circ\text{C}$; SBC Normal Mode; all voltages with respect to ground; positive current defined flowing into pin (unless otherwise specified)

Parameter	Symbol	Values			Unit	Note or Test Condition	Number
		Min.	Typ.	Max.			
FO and Alternative Function GPIO							
FO Low-Side output voltage (active)	$V_{FO,L1}$	-	-	1	V	If configured as Fail-Output; $I_{FO} = 4.0\text{mA}$	P_12.2.1
GPIO Low-Side output voltage (active)	$V_{GPIO,L1}$	-	-	1	V	If configured as Low-Side Switch $I_{GPIO} = 30\text{mA}$	P_12.2.3
GPIO Low-Side output voltage (active)	$V_{GPIO,L2}$	-	-	5	mV	¹⁾ If configured as Low-Side Switch; $I_{GPIO} = 100\mu\text{A}$	P_12.2.4
GPIO High-Side output voltage (active)	$V_{GPIO,H1}$	VS-1	-	-	V	If configured as High-Side Switch; $I_{GPO} = -30\text{mA}$	P_12.2.5
GPIO High-Side output voltage (active)	$V_{GPIO,H2}$	VS-5	-	-	mV	¹⁾ If configured as High-Side Switch; $I_{GPO} = -100\mu\text{A}$	P_12.2.6
GPIO input threshold voltage (WK config)	$V_{GPIOI,th}$	1.5	2.5	3.5	V	hysteresis included; pull-up / pull-down sources disabled	P_12.2.7
GPIO input threshold hysteresis (WK config)	$V_{GPIOI,hys}$	0.6	0.9	1.3	V	¹⁾ pull-up / pull-down sources disabled	P_12.2.8
GPIO input filter time (WK config)	$t_{F_GPIO_WK}$	13	16	20	μs	²⁾	P_12.2.19
FO/GPIO input leakage current (all inactive)	$I_{GPIO,LK}$	-2	-	2	μA	$0\text{V} < V_{GPIO} < \text{VS}$	P_12.2.9
GPIO wake input activation blanking time	$t_{GPIO,WK,blank}$	24	30	40	μs	²⁾ after enabling as wake input	P_12.2.10
GPIO LS overcurrent Shutdown Threshold	$I_{GPIO,SD}$	30	-	65	mA	$V_{GPIO} = \text{VS}$, hysteresis included	P_12.2.11
GPIO HS overcurrent Shutdown Threshold	$I_{GPIO,SD}$	-65	-	-30	mA	$V_{GPIO} = 0\text{V}$, hysteresis included	P_12.2.12
GPIO overcurrent shutdown filter time	$t_{GPIO,OC}$	20	26	32	μs	²⁾ applies for HS and LS configuration	P_12.2.13
GPIO HS open load detection	$I_{GPIO,OL}$	-3.0	-	-0.5	mA	in On-state, hysteresis included	P_12.2.15

Fail Output (FO) and General Purpose I/O (GPIO)

Table 23 Electrical Characteristics (cont'd)

$V_S = 5.5\text{ V to }28\text{ V}$; $T_j = -40^\circ\text{C to }+150^\circ\text{C}$; SBC Normal Mode; all voltages with respect to ground; positive current defined flowing into pin
(unless otherwise specified)

Parameter	Symbol	Values			Unit	Note or Test Condition	Number
		Min.	Typ.	Max.			
GPIO open load detection filter time	$t_{\text{GPIO,OL}}$	51	64	80	μs	²⁾	P_12.2.16
GPIO WK pin Pull-up Current	$I_{\text{PU_GPIO,WK}}$	-20	-10	-3	μA	$V_{\text{GPIO,WK_IN}} = 3.5\text{V}$	P_12.3.17
GPIO WK pin Pull-down Current	$I_{\text{PD_GPIO,WK}}$	3	10	20	μA	$V_{\text{GPIO,WK_IN}} = 1.5\text{V}$	P_12.3.18

- 1) Not subject to production test, specified by design.
- 2) Not subject to production test, tolerance defined by internal oscillator tolerance

12 Supervision Functions

12.1 Reset Function

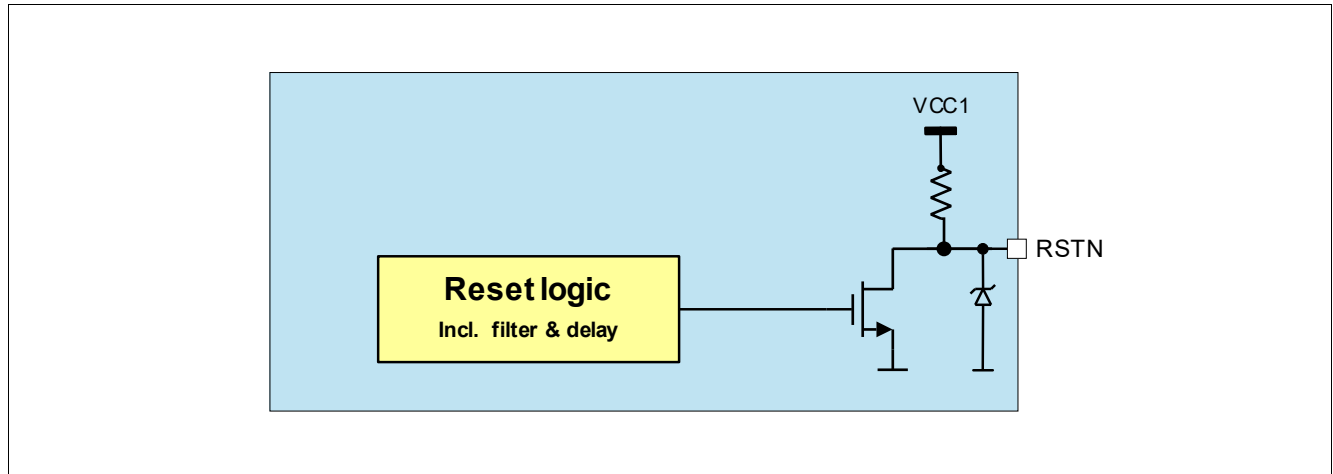

Figure 31 Reset Block Diagram

12.1.1 Reset Output Description

The reset output pin RSTN provides a reset information to the microcontroller, e.g. in the event that the output voltage has fallen below the undervoltage threshold $V_{RT1/2/3/4}$. In case of a reset event, the reset output RSTN is pulled to Low after the filter time t_{RF} and stays Low as long as the reset event is present and the configurable reset delay time has not expired. The reset delay time can be configured. The default value is the extended reset delay time t_{RD1} and the reduced reset delay time t_{RD2} can be selected by setting **RSTN_DEL**. When connecting the SBC to battery voltage, the reset signal remains Low initially. When the output voltage V_{CC1} has reached the reset default threshold $V_{RT1,r}$, the reset output RSTN is released to High after the reset delay time t_{RD1} . A reset can also occur due to a watchdog trigger failure. The reset threshold can be adjusted via SPI, the default reset threshold is $V_{RT1,f}$. The RSTN pin has an integrated pull-up resistor. In case reset is triggered, it is pulled Low for $V_{CC1} \geq 1V$ and for $V_S \geq V_{POR,f}$ (see also [Chapter 12.3](#)).

The timings for the RSTN triggering regarding VCC1 undervoltage and watchdog trigger is shown in [Figure 32](#).

Supervision Functions

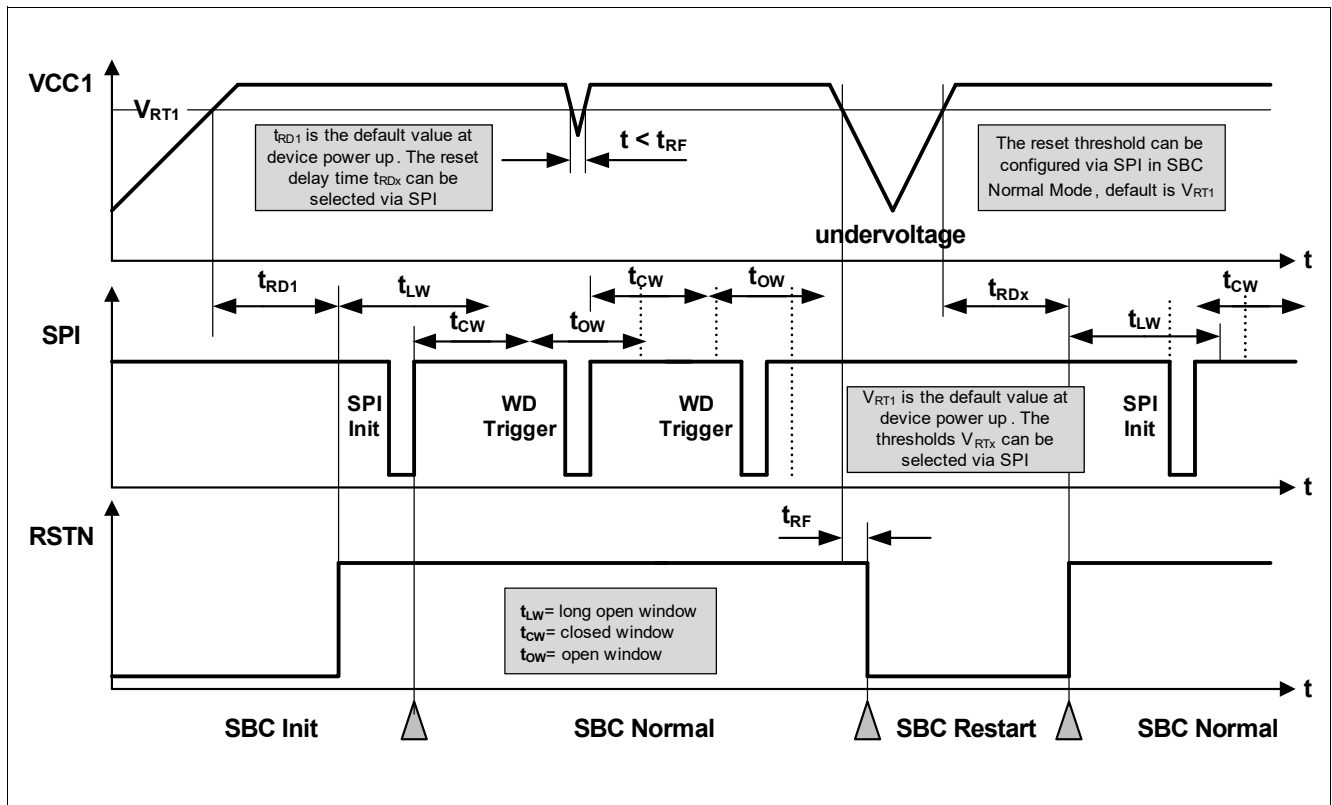

Figure 32 Reset Timing Diagram

12.1.2 Soft Reset Description

In SBC Normal and SBC Stop Mode, it is also possible to trigger a device internal reset via a SPI command in order to bring the SBC into a defined state in case of failures. In this case the microcontroller must send a SPI command and set the **MODE** bits to '11' in the **M_S_CTRL** register. As soon as this command becomes valid, the SBC is set back to SBC INIT Mode and all SPI registers are set to their default values (see SPI [Chapter 13.5](#) and [Chapter 13.6](#)).

Two different soft reset configurations are possible via the SPI bit **SOFT_RESET_RST**:

- **SOFT_RESET_RST** = '0': The reset output (RSTN) is triggered when the soft reset is executed (default setting, the same reset delay time t_{RD1} applies)
- **SOFT_RESET_RST** = '1': The reset output (RSTN) is not triggered when the soft reset is executed

Note: The device must be in SBC Normal Mode or SBC Stop Mode when sending this command. Otherwise, the command is ignored.

Supervision Functions

12.2 Watchdog Function

The watchdog is used to monitor the software execution of the microcontroller and to trigger a reset if the microcontroller stops serving the watchdog due to a lock up in the software.

Two different types of watchdog functions are implemented and can be selected via the bit **WD_WIN**:

- Time-Out Watchdog (default value)
- Window Watchdog

The respective watchdog functions can be selected and programmed in SBC Normal Mode. The configuration stays unchanged in SBC Stop Mode.

Please refer to **Table 24** to match the SBC Modes with the respective watchdog modes.

Table 24 Watchdog Functionality by SBC Modes

SBC Mode	Watchdog Mode	Remarks
INIT Mode	Starts with Long Open Window	Watchdog starts with Long Open Window after RSTN is released
Normal Mode	WD Programmable	Window Watchdog, Time-Out watchdog or switched Off for SBC Stop Mode
Stop Mode	Watchdog is fixed or Off	
Sleep Mode	Off	SBC starts with Long Open Window when entering SBC Normal Mode.
Restart Mode	Off	SBC starts with Long Open Window when entering SBC Normal Mode.

The watchdog timing is programmed via SPI command in the register **WD_CTRL**. As soon as the watchdog is programmed, the timer starts with the new setting and the watchdog must be served. The watchdog is triggered by sending a valid SPI-write command to the watchdog configuration register. The watchdog trigger command is executed when the SPI command is interpreted, i.e. 3 clock cycles (typ. 3µs) after the transition of Chip Select input (CSN) from Low to High.

When coming from SBC Init, SBC Restart Mode or in certain cases from SBC Stop Mode, the watchdog timer is always started with a long open window. The long open window ($t_{LW} = 200ms$) allows the microcontroller to run its initialization sequences and then to trigger the watchdog via SPI.

The watchdog timer period can be selected via the watchdog timing bit field (**WD_TIMER**) and is in the range of 10 ms to 10000 ms. This setting is valid for both watchdog types.

The following watchdog timer periods are available:

- WD Setting 1: 10ms
- WD Setting 2: 20ms
- WD Setting 3: 50ms
- WD Setting 4: 100ms
- WD Setting 5: 200ms
- WD Setting 6: 500ms
- WD Setting 7: 1000ms
- WD Setting 8: 10000ms

In case of a watchdog reset, SBC Restart or SBC Fail-Safe Mode is entered according to the configuration and the SPI bits **WD_FAIL** are set. Once the RSTN goes High again the watchdog immediately starts with a long open window the SBC enters automatically SBC Normal Mode.

Supervision Functions

In SBC Development Mode the watchdog is Off and therefore no reset is generated due to a watchdog failure.

Depending on the configuration, the **WD_FAIL** bits are set after a watchdog trigger failure as follows:

- In case an incorrect WD trigger is received (triggering in the closed watchdog window or when the watchdog counter expires without a valid trigger) then the **WD_FAIL** bits are incremented (showing the number of incorrect WD triggers)
- For config 2: the bits can have the maximum value of ‘01’
- For config 1, 3 and 4: the bits can have the maximum value of ‘10’

The **WD_FAIL** bits are cleared automatically if following conditions apply:

- After a successful watchdog trigger
- When the watchdog is Off: in SBC Stop Mode after successfully disabling the watchdog, in SBC Sleep Mode, or in SBC Fail-Safe Mode (except for a watchdog failure)

12.2.1 Time-Out Watchdog

The time-out watchdog is an easier but less secure watchdog than a window watchdog because the watchdog trigger can be set at any time within the configured watchdog timer period.

A correct watchdog service immediately results in starting a new watchdog timer period. Taking the tolerances of the internal oscillator into account the safe trigger area is defined in **Figure 33**.

If the time-out watchdog period elapses, a watchdog reset is created by setting the reset output RSTN Low and the SBC switches to SBC Restart or SBC Fail-Safe Mode.

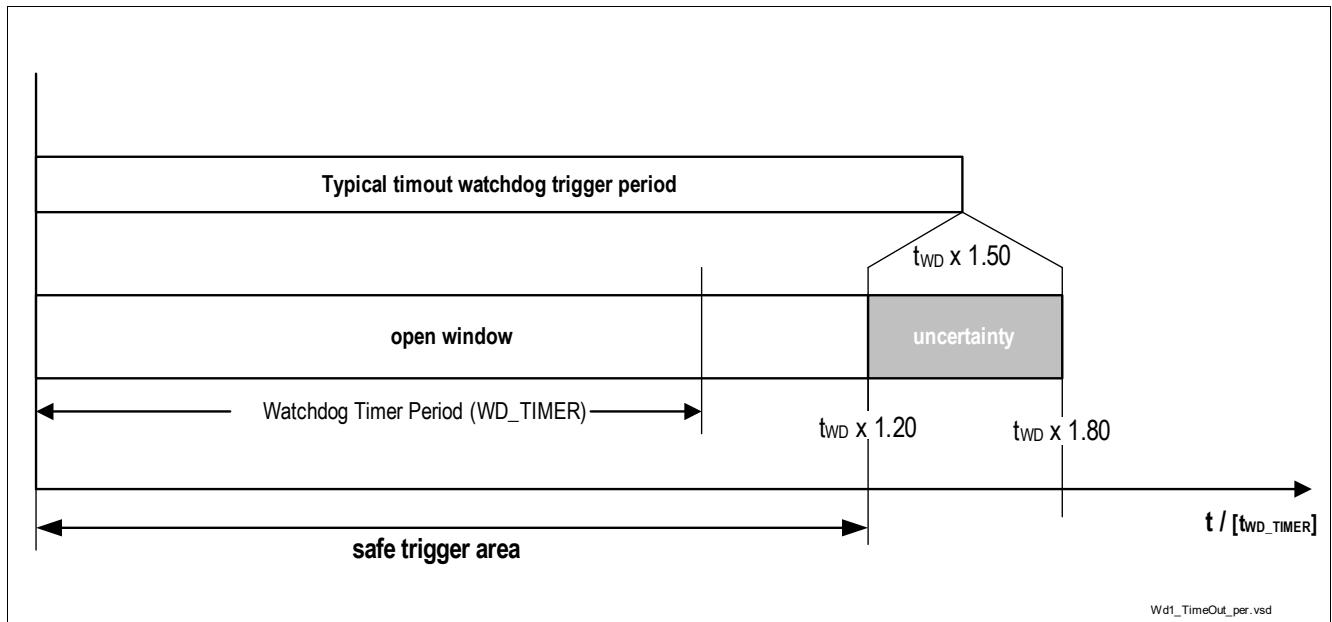

Figure 33 Time-out Watchdog Definitions

12.2.2 Window Watchdog

Compared to the time-out watchdog the characteristic of the window watchdog is that the watchdog timer period is divided into a closed and an open window. The watchdog must be triggered within the open window. A correct watchdog trigger results in starting the window watchdog period with a closed window followed by an open window.

Supervision Functions

The watchdog timer period is also the typical trigger time and defines the middle of the open window. Taking the oscillator tolerances into account leads to a safe trigger area of:

$$t_{WD} \times 0.72 < \text{safe trigger area} < t_{WD} \times 1.20.$$

The typical closed window is defined to a width of 60% of the selected window watchdog timer period. Taking the tolerances of the internal oscillator into account leads to the timings as defined in **Figure 34**.

A correct watchdog service immediately results in starting the next closed window.

If the trigger signal meets the closed window or the watchdog timer period elapses, then a watchdog reset is created by setting the reset output RSTN Low and the SBC switches to SBC Restart or SBC Fail-Safe Mode.

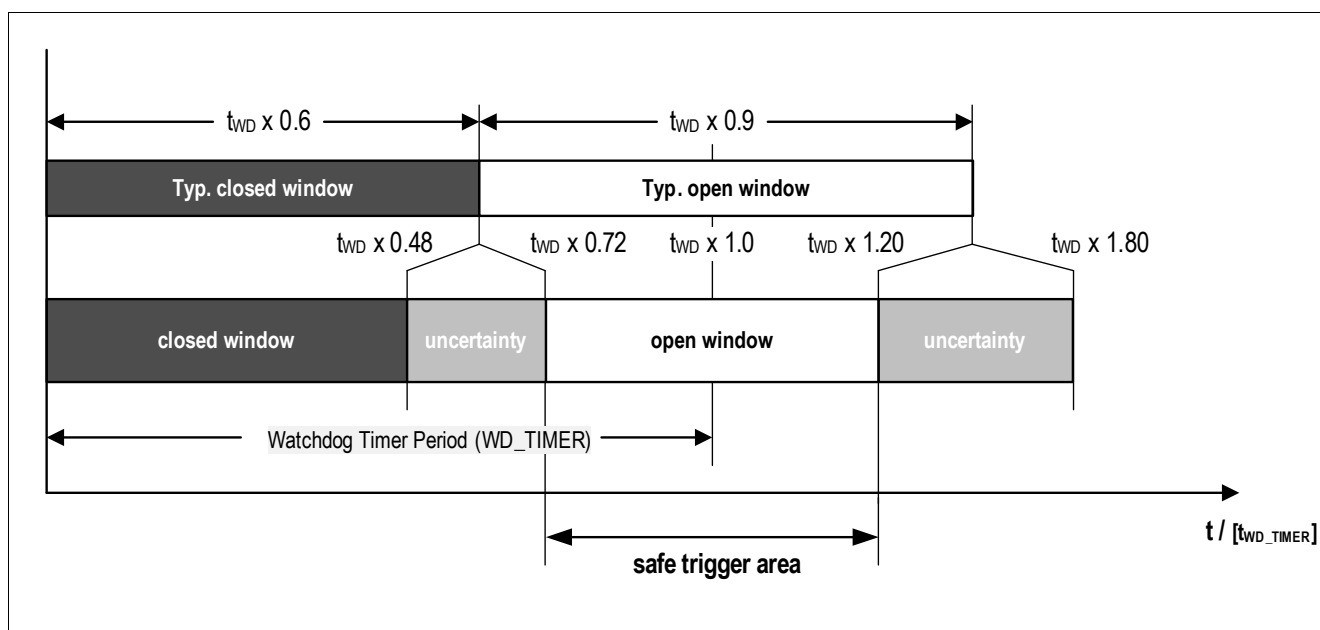

Figure 34 Window Watchdog Definitions

12.2.3 Watchdog Setting Check Sum

A check sum bit is part of the SPI command to trigger the watchdog and to set the watchdog setting.

The sum of the 8 data bits in the register **WD_CTRL** needs to have even parity (see **Equation (12.1)**). This is realized by either setting the bit **CHECKSUM** to 0 or 1. If the check sum is wrong, then the SPI command is ignored, i.e. the watchdog is not triggered or the settings are not changed and the bit **SPI_FAIL** is set.

The checksum is calculated by taking all 8 data bits into account. The written value of the reserved bit 3 of the **WD_CTRL** register is considered (even if read as '0' in the SPI output) for checksum calculation, i.e. if a '1' is written on the reserved bit position, then a '1' is used in the checksum calculation.

$$(12.1)$$

$$CHKSUM = \text{Bit15} \oplus \dots \oplus \text{Bit8}$$

12.2.4 Watchdog during SBC Stop Mode

The watchdog can be disabled for SBC Stop Mode in SBC Normal Mode. For safety reasons a special sequence must be followed in order to disable the watchdog as described in **Figure 35**. Two different SPI bits (**WD_STM_EN_0**, **WD_STM_EN_1**) in the registers **WK_CTRL_0** and **WD_CTRL** need to be set.

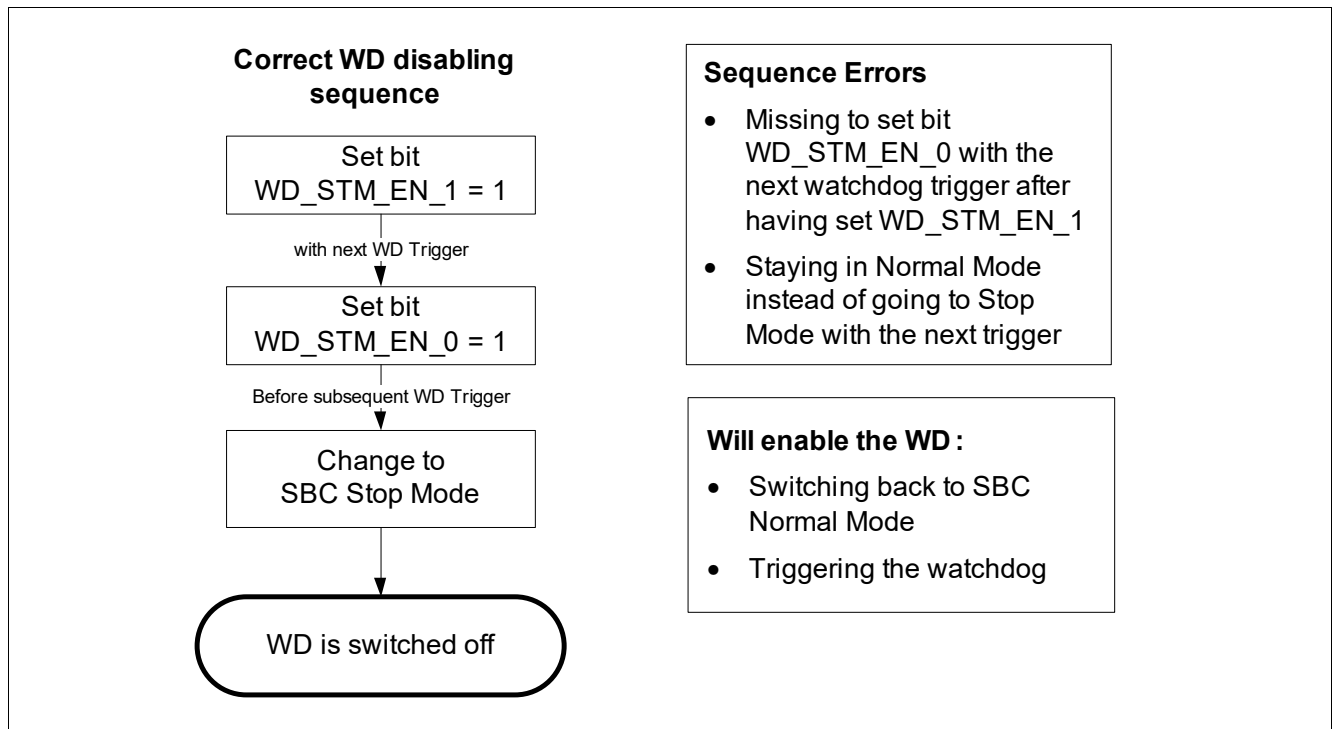

Figure 35 Watchdog disabling sequence in SBC Stop Mode

If a sequence error occurs, then the bit **WD_STM_EN_1** is cleared and the sequence has to be started again. The watchdog can be enabled by triggering the watchdog in SBC Stop Mode or by switching back to SBC Normal Mode via SPI command. In both cases the watchdog starts with a long open window and the bits **WD_STM_EN_1** and **WD_STM_EN_0** are cleared. After the long open window the watchdog has to be served as configured in the **WD_CTRL** register.

*Note: The bit **WD_STM_EN_0** is cleared automatically when the sequence is started and it was '1' before. **WD_STM_EN_0** can also not be set if **WD_STM_EN_1** isn't yet set.*

12.2.5 Watchdog Start in SBC Stop Mode due to Bus Wake

In SBC Stop Mode the Watchdog can be disabled. In addition a feature is available that starts the watchdog with any Bus wake (CAN) during SBC Stop Mode. This feature is enabled by setting the bit **WD_EN_WK_BUS** = 1 (= default value after POR). The bit can only be changed in SBC Normal Mode and needs to be programmed before starting the watchdog disabling sequence.

A wake on CAN generates an interrupt and the RXD pin for CAN is pulled to Low. By these signals the microcontroller is informed that the watchdog is started with a long open window. After the long open window the watchdog has to be served as configured in the **WD_CTRL** register.

To disable the watchdog again, the SBC has to be switched to Normal Mode and the sequence has to be sent again.

Supervision Functions

12.3 VS Power-On Reset

At power up of the device, the VS Power-on Reset is detected when $VS > V_{POR,r}$ and the SPI bit **POR** is set to indicate that all SPI registers are set to POR default settings. VCC1 is starting up and the reset output RSTN is kept Low. It will only be released once VCC1 has crossed $V_{RT1,r}$ and t_{RD1} has elapsed.

In case $VS < V_{POR,f}$ a device internal reset is generated and the SBC is switched Off and restarts in INIT mode with the next VS rising. This is shown in **Figure 36**.

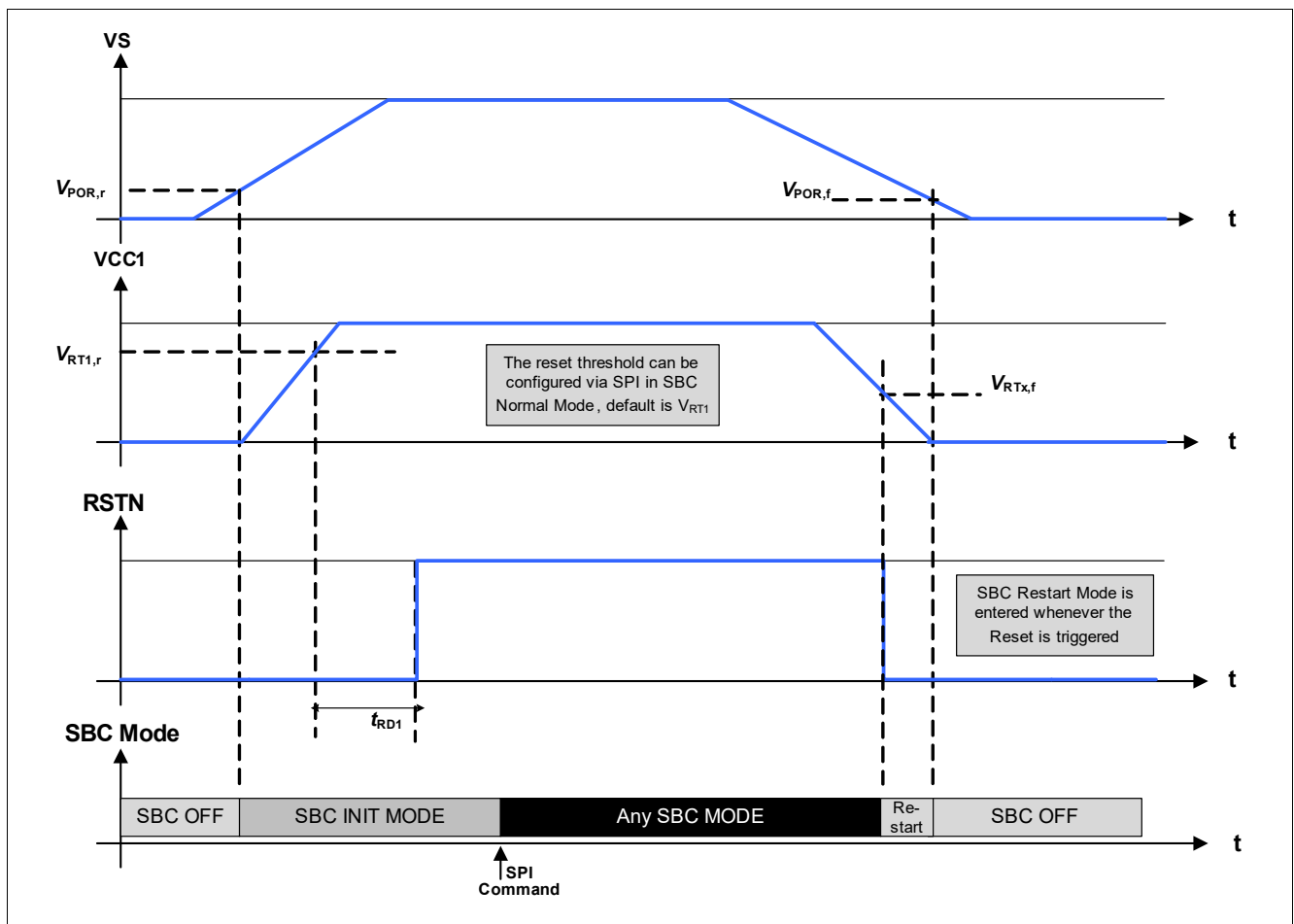

Figure 36 Ramp up / down example of Supply Voltage

12.4 VS Under- and Overvoltage

12.4.1 VS Undervoltage

The VS under-voltage monitoring is always active in SBC Init-, Restart- and Normal Mode (see below conditions for SBC Stop Mode). If the supply voltage VS reaches the undervoltage threshold $V_{s,uv}$ then the SBC triggers the following actions:

- SPI bit **VS_UV** is set. No other error bits are set. The bit can be cleared once the VS undervoltage condition is not present anymore
- The VCC1 short circuit protection becomes inactive (see [Chapter 12.6](#)). However, the thermal protection of the device remains active. If the undervoltage threshold is exceeded (VS rising) then the function is automatically enabled again

Note: VS under-voltage monitoring is not available in SBC Stop Mode due to current consumption saving requirements except if the VCC1 load current is above the active peak threshold (I_{PEAK_TH}) or if VCC1 is below the VCC1 prewarning threshold.

12.4.2 VS Overvoltage

The VS over-voltage monitoring is always active SBC Init-, Restart- and Normal Mode (see below note for conditions in SBC Stop Mode) or when the charge pump is enabled. If the supply voltage VS reaches the over-voltage threshold $V_{s,ov}$ then the SBC does the following measures:

- SPI bit **VS_OV** is set. This bit is intended for diagnosis only, i.e. or other error bits are set. The bit can be cleared once the VS over-voltage condition is not present anymore

If the charge pump is disabled after the bit $V_{s,ov}$ was set then the bit will stay set until it is cleared via SPI.

Note: VS over-voltage monitoring is not available in SBC Stop Mode due to current consumption saving requirements except if the VCC1 load current is above the active peak threshold (I_{PEAK_TH}) or if VCC1 is below the VCC1 prewarning threshold.

12.5 VCC1 Over-/ Undervoltage and Undervoltage Prewarning

12.5.1 VCC1 Undervoltage and Undervoltage Prewarning

This function is always active when the VCC1 voltage regulator is enabled. The supervision is implemented at the pin VIO (VIO must be connected to VCC1).

A first-level voltage detection threshold is implemented as a prewarning for the microcontroller. The prewarning event is signaled with the bit **VCC1_WARN**. No other actions are taken.

As described in [Chapter 12.1](#) and [Figure 37](#), a reset is triggered (RSTN pulled Low) when the V_{CC1} output voltage falls below the selected undervoltage threshold (V_{RTX}). The SBC enters SBC Restart Mode and the bit **VCC1_UV** is set when RSTN is released again.

The hysteresis of the VCC1 undervoltage threshold can be increased by setting the bit **RSTN_HYS**. In this case always the highest rising threshold ($V_{rt1,r}$) is used for the release of the undervoltage reset. The falling reset threshold remains as configured.

*Note: The **VCC1_WARN** or **VCC1_UV** bits are not set in Sleep Mode as $V_{CC1} = 0V$ in this case*

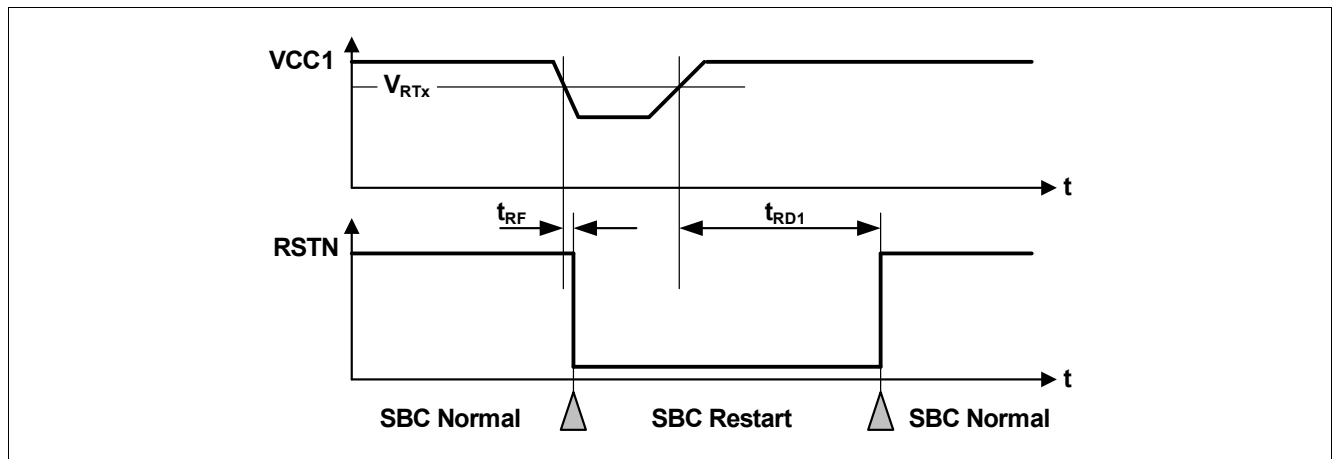

Figure 37 VCC1 Undervoltage Timing Diagram

Note: It is recommended to clear the **VCC1_WARN** and **VCC1_UV** bit once it is detected by the microcontroller software to verify whether the undervoltage is still present.

12.5.2 VCC1 Overvoltage

For fail-safe reasons a configurable VCC1 over voltage detection feature is implemented. It is active when the VCC1 voltage regulator is enabled. The supervision is implemented at the pin VIO (VIO must be connected to VCC1).

In case the $V_{CC1,OV,r}$ threshold is crossed, the SBC triggers following measures (depending on the configuration):

- The bit **VCC1_OV** is always set;
- If the bit **VCC1_OV_RST** is set and **CFG0_STATE** = '1', then SBC Restart Mode is entered. The FO output is activated. After the reset delay time (t_{RD1}), the SBC Restart Mode is left and SBC Normal Mode is resumed even if the VCC1 over voltage event is still present (see also Figure 38). The **VCC1_OV_RST** bit is cleared automatically;
- If the bit **VCC1_OV_RST** is set and **CFG0_STATE** = '0', then SBC Fail-Safe Mode is entered and FO output is activated.

Note: External noise could be coupled into the VCC1 supply line. Especially, in case the VCC1 output current in SBC STOP Mode is below the active peak threshold ($I_{VCC1,peak}$) it should be considered to clear the bit **VCC1_OV_RST** before entering SBC Stop Mode to avoid unintentional SBC Restart or Fail-Safe Mode entry and to ignore the **VCC1_OV** bit due to external noise.

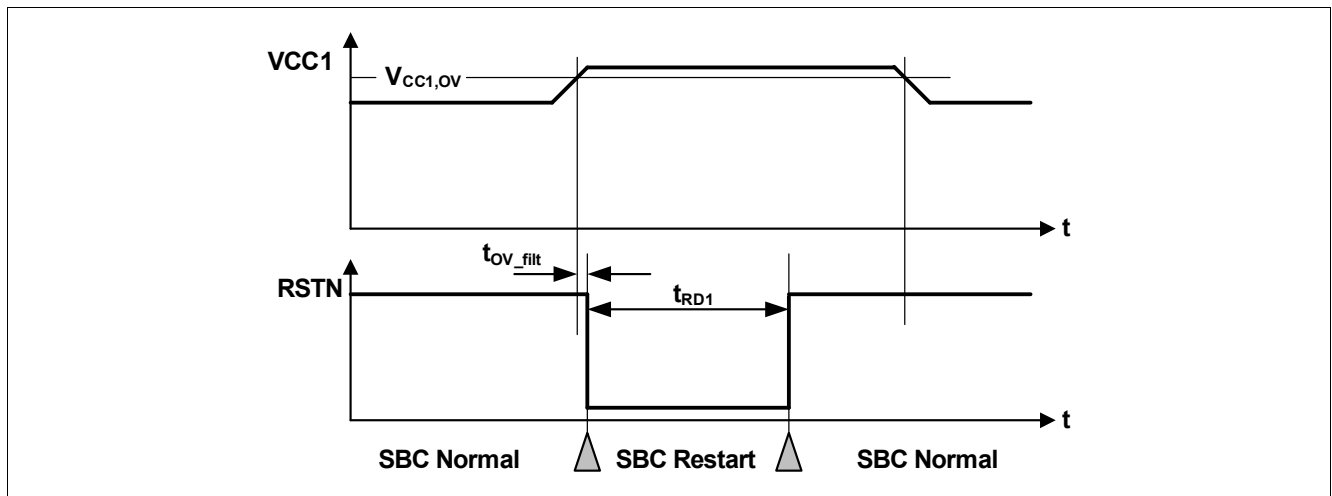

Figure 38 VCC1 Over Voltage Timing Diagram

12.6 VCC1 Short Circuit Diagnostics

The supervision is implemented at the pin VIO (VIO must be connected to VCC1).

The short circuit protection feature for V_{CC1} is implemented as follows:

- The short circuit detection is only enabled if $V_S > V_{S,UV}$
- If V_{CC1} is not above the V_{RTX} within $t_{VCC1,SC}$ after device power up or after waking from SBC Sleep or Fail-Safe Mode (i.e. after V_{CC1} is enabled) then the SPI bit **VCC1_SC** bit is set, V_{CC1} is turned Off, the FO pin is enabled, **FAILURE** is set and SBC Fail-Safe Mode is entered. The SBC can be activated again via a wake-up on CAN and WK or GPIO if configured as wake input.
- The same behavior applies, if V_{CC1} falls below V_{RTX} for longer than $t_{VCC1,SC}$.

12.7 VCC2 Undervoltage and VCAN Undervoltage

An undervoltage warning is implemented for V_{CC2} and V_{CAN} as follows:

- V_{CC2} undervoltage detection: In case V_{CC2} is enabled and drops below the $V_{CC2,UV,f}$ threshold, then the SPI bit **VCC2_UV** is set and can be only cleared via SPI. During power-up the blanking time $t_{VCC2,Blank}$ applies, i.e. no undervoltage warning bit is set during this time.
- V_{CAN} undervoltage detection: In case *the CAN module is enabled and the voltage on V_{CAN}* drops below the $V_{CAN,UV,f}$ threshold, then the SPI bit **VCAN_UV** is set and can be only cleared via SPI.

Note: The VCC2_UV flag is not set during turn-On or turn-Off of V_{CC2} .

12.8 Thermal Protection

Three independent and different thermal protection features are implemented in the SBC according to the system impact:

- Individual thermal shutdown of specific blocks
- Temperature prewarning of main microcontroller supply VCC1
- SBC thermal shutdown due to VCC1 overtemperature

12.8.1 Individual Thermal Shutdown

As a first-level protection measure the output stages VCC2 and CAN are independently switched Off if the respective block reaches the temperature threshold $T_{jTSD1_1} / T_{jTSD1_2}$. Then the **TSD1** bit is set. This bit can only be cleared via SPI once the overtemperature is not present anymore. Independent of the SBC Mode the thermal shutdown protection is only active if the respective block is On.

The respective modules behave as follows:

- VCC2: Is switched to Off and the control bits **VCC2_ON** are cleared. The status bit **VCC2_OT** is set. Once the overtemperature condition is not present anymore, then VCC2 has to be configured again by SPI.
- CAN: The transmitter is disabled and stays in CAN Normal Mode acting like CAN Receive only mode. The status bits **CAN_FAIL** = '01' are set. Once the overtemperature condition is not present anymore, then the CAN transmitter is automatically switched On.

Note: The diagnosis bits are not cleared automatically and have to be cleared via SPI once the overtemperature condition is not present anymore.

12.8.2 Temperature Prewarning

As a next level of thermal protection a temperature prewarning is implemented. If the main supply VCC1 exceeds the thermal prewarning temperature threshold T_{jPW} . Then the status bit **TPW** is set. This bit can only be cleared via SPI once the overtemperature is not present anymore.

12.8.3 SBC Thermal Shutdown

As the highest level of thermal protection a temperature shutdown of the SBC is implemented if the main supply VCC1 reaches the thermal shutdown temperature threshold $T_{jTSD1_1} / T_{jTSD1_2}$. Once a TSD2 event is detected SBC Fail-Safe Mode is entered. Only when device temperature falls below the TSD2 threshold then the device remains in SBC Fail-Safe Mode for t_{TSD2} to allow the device to cool down. After this time has expired, the SBC automatically changes via SBC Restart Mode to SBC Normal Mode (see also **Chapter 5.1.6**).

When a TSD2 event is detected, then the status bit **TSD2** is set. This bit can only be cleared via SPI in SBC Normal Mode once the overtemperature is not present anymore.

For increased robustness it is possible to extend the TSD2 waiting time by 64x of t_{TSD2} after 16 consecutive TSD2 events by setting the SPI bit **TSD2_DEL**. The counter is incremented with each TSD2 event even if the bit **TSD2** is not cleared. Once the counter has reached the value 16, then the bit **TSD2_SAFE** is set and the extended TSD2 waiting time is active. The extended waiting time is kept until **TSD2_SAFE** is cleared. The TSD counter is cleared when **TSD2** or **TSD2_DEL** is cleared.

Note: In case a TSD2 overtemperature occurs while entering SBC Sleep Mode then SBC Fail-Safe mode is entered.

*Note: To enable higher ambient temperatures the thermal shutdown thresholds can be increased by 10K for TSD1 and TSD2 by setting the bit **TSD_THR**.*

Supervision Functions

12.9 Electrical Characteristics

Table 25 Electrical Characteristics

$V_S = 5.5\text{ V to }28\text{ V}$; $T_j = -40^\circ\text{C to }+150^\circ\text{C}$; SBC Normal Mode; all voltages with respect to ground; positive current defined flowing into pin (unless otherwise specified)

Parameter	Symbol	Values			Unit	Note or Test Condition	Number
		Min.	Typ.	Max.			
VCC1 Monitoring;							
Undervoltage Prewarning Threshold Voltage PW,f	$V_{PW,f}$	4.53	4.70	4.84	V	VCC1 falling, SPI bit is set	P_13.9.1
Undervoltage Prewarning Threshold Voltage PW,r	$V_{PW,r}$	4.60	4.75	4.90	V	VCC1 rising	P_13.9.2
Undervoltage Prewarning Threshold Voltage hysteresis	$V_{PW,hys}$	30	50	90	mV	⁵⁾	P_13.9.3
VCC1 UV Prewarning Detection Filter Time	t_{VCC1,PW_F}	5	10	14	us	³⁾ rising and falling	P_13.9.4
Reset Threshold Voltage RT1,f	$V_{RT1,f}$	4.45	4.6	4.75	V	default setting; VCC1 falling	P_13.9.5
Reset Threshold Voltage RT1,r	$V_{RT1,r}$	4.58	4.74	4.90	V	default setting; VCC1 rising	P_13.9.6
Reset Threshold Voltage RT2,f	$V_{RT2,f}$	3.70	3.85	4.00	V	VCC1 falling	P_13.9.7
Reset Threshold Voltage RT2,r	$V_{RT2,r}$	3.85	4.0	4.15	V	VCC1 rising	P_13.9.8
Reset Threshold Voltage RT3,f	$V_{RT3,f}$	3.24	3.40	3.55	V	$V_S \geq 4\text{V}$; VCC1 falling	P_13.9.9
Reset Threshold Voltage RT3,r	$V_{RT3,r}$	3.39	3.54	3.70	V	$V_S \geq 4\text{V}$; VCC1 rising	P_13.9.10
Reset Threshold Voltage RT4,f	$V_{RT4,f}$	2.49	2.65	2.8	V	$V_S \geq 4\text{V}$; VCC1 falling	P_13.9.11
Reset Threshold Voltage RT4,r	$V_{RT4,r}$	2.65	2.76	2.95	V	$V_S \geq 4\text{V}$; VCC1 rising	P_13.9.12
Reset Threshold Hysteresis	$V_{RT,hys}$	70	140	220	mV	⁵⁾	P_13.9.13
VCC1 Over Voltage Detection Threshold Voltage	$V_{CC1,OV,r}$	5.6	5.8	6.0	V	¹⁵⁾ rising VCC1	P_13.9.26
VCC1 Over Voltage Detection Threshold Voltage	$V_{CC1,OV,f}$	5.48	5.65	5.82	V	⁵⁾ falling VCC1	P_13.9.27
VCC1 Over Voltage Detection hysteresis	$V_{CC1,OV,hys}$	50	160	200	mV	⁵⁾	P_13.9.30
VCC1 OV Detection Filter Time	t_{VCC1,OV_F}	51	64	80	us	³⁾	P_13.9.31

Supervision Functions

Table 25 Electrical Characteristics (cont'd)

$V_S = 5.5\text{ V to }28\text{ V}$; $T_j = -40^\circ\text{C to }+150^\circ\text{C}$; SBC Normal Mode; all voltages with respect to ground; positive current defined flowing into pin (unless otherwise specified)

Parameter	Symbol	Values			Unit	Note or Test Condition	Number
		Min.	Typ.	Max.			
VCC1 Short to GND Filter Time	$t_{VCC1,SC}$	1.6	2	2.4	ms	³⁾ blanking time during power-up, short circuit detection for $V_S \geq V_{S,UV}$	P_13.9.32

Reset Generator; Pin RSTN

Reset Low Output Voltage	$V_{RSTN,L}$	–	0.2	0.4	V	$I_{RSTN} = 1\text{ mA}$ for $V_{CC1} \geq 1\text{ V}$ & $V_S \geq V_{POR,f}$	P_13.9.33
Reset High Output Voltage	$V_{RSTN,H}$	$0.8 \times V_{CC1}$	–	$V_{CC1} + 0.3\text{ V}$	V	$I_{RSTN} = -20\text{ }\mu\text{A}$	P_13.9.34
Reset Pull-up Resistor	R_{RSTN}	10	20	40	k Ω	$V_{RSTN} = 0\text{ V}$	P_13.9.35
Reset Filter Time	t_{RF}	4	10	26	μs	³⁾ $V_{CC1} < V_{RT1x}$ to RSTN = L see also Chapter 12.3	P_13.9.36
Reset Delay Time (long)	t_{RD1}	8	10	12	ms	^{2) 3)} RSTN_DEL = '0' (default value)	P_13.9.37
Reset Delay Time (reduced)	t_{RD2}	1.6	2	2.4	ms	^{2) 3)} RSTN_DEL = '1'	P_13.9.70

VCC2 Monitoring

VCC2 Undervoltage Threshold Voltage (falling)	$V_{CC2,UV,f}$	4.5	–	4.75	V	VCC2 falling	P_13.9.38
VCC2 Undervoltage Threshold Voltage (rising)	$V_{CC2,UV,r}$	4.6	–	4.85	V	VCC2 rising	P_13.9.39
VCC2 Undervoltage detection hysteresis	$V_{CC2,UV,hys}$	70	150	250	mV	⁵⁾	P_13.9.40
VCC2 Undervoltage Detection Filter Time	$t_{VCC2,UV,F}$	5	10	14	μs	³⁾ rising and falling	P_13.9.41
VCC2 UV Blanking Time	$t_{VCC2,Blank}$	3.2	4	4.8	ms	³⁾ after switching On	P_13.9.42

VCAN Monitoring

CAN Supply undervoltage detection threshold (falling)	$V_{CAN,UV,f}$	4.5	–	4.75	V	VCAN falling	P_13.9.43
CAN Supply undervoltage detection threshold (rising)	$V_{CAN,UV,r}$	4.6	–	4.85	V	VCAN rising	P_13.9.44
VCAN Undervoltage detection hysteresis	$V_{CAN,UV,hys}$	70	150	250	mV	⁵⁾	P_13.9.45
VCAN UV detection Filter Time	$t_{VCAN,UV,F}$	4.2	10	14	μs	³⁾ VCAN rising and falling	P_13.9.46

Supervision Functions

Table 25 Electrical Characteristics (cont'd)

$V_S = 5.5\text{ V to }28\text{ V}$; $T_j = -40^\circ\text{C to }+150^\circ\text{C}$; SBC Normal Mode; all voltages with respect to ground; positive current defined flowing into pin (unless otherwise specified)

Parameter	Symbol	Values			Unit	Note or Test Condition	Number
		Min.	Typ.	Max.			
Watchdog Generator / Internal Oscillator							
Long Open Window	t_{LW}	160	200	240	ms	³⁾	P_13.9.47
Internal Clock Generator Frequency	$f_{CLKSBC,1}$	0.8	1.0	1.2	MHz	–	P_13.9.48
Internal Oscillator 2MHz for Charge Pump	$f_{CLKSBC,2}$	1.8	2.0	2.2	MHz	2MHZ_FREQ ='001';	P_13.9.65
Minimum Waiting time during SBC Fail-Safe Mode							
Min. waiting time Fail-Safe	$t_{FS,min}$	80	100	120	ms	³⁾⁴⁾	P_13.9.49
Power-On Reset, Over / Undervoltage Protection							
VS Power-on reset rising	$V_{POR,r}$	–		4.5	V	VS increasing	P_13.9.50
VS Power-on reset falling	$V_{POR,f}$	–		3	V	VS decreasing	P_13.9.51
VS Undervoltage Detection Threshold	$V_{S,UV}$	5.3	–	6.0	V	Supply UV threshold for VCC1 SC detection; hysteresis included; includes rising and falling threshold	P_13.9.52
VS Undervoltage Detection Hysteresis	$V_{S,UV,hys}$	180	220	260	mV	⁵⁾	P_13.9.67
VS Undervoltage Detection Filter Time	$t_{VS,UV}$	5	10	14	us	³⁾ rising and falling	P_13.9.62
VS Over voltage Detection Threshold	$V_{S,OV}$	22	–	25	V	⁵⁾ Supply OV threshold; only SPI diagnosis bit is set; includes rising and falling threshold	P_13.9.63
VS Overvoltage Detection Filter Time	$t_{VS,OV}$	5	10	14	us	³⁾ rising and falling	P_13.9.64
VS Overvoltage Detection Hysteresis	$V_{S,OV,hys}$	0.3	–	0.55	V	⁵⁾	P_13.9.69
Overtemperature Shutdown⁵⁾							
Thermal Prewarning Temperature	T_{jPW}	125	145	165	°C	T_j rising	P_13.9.54

Supervision Functions

Table 25 Electrical Characteristics (cont'd)

$V_S = 5.5\text{ V to }28\text{ V}$; $T_j = -40^\circ\text{C to }+150^\circ\text{C}$; SBC Normal Mode; all voltages with respect to ground; positive current defined flowing into pin (unless otherwise specified)

Parameter	Symbol	Values			Unit	Note or Test Condition	Number
		Min.	Typ.	Max.			
Thermal Shutdown TSD1	T_{jTSD1_1}	170	185	200	°C	T_j rising; TSD_THR = 0	P_13.9.55
Thermal Shutdown TSD1 (high temp)	T_{jTSD1_2}	180	195	210	°C	T_j rising; TSD_THR = 1	P_13.9.60
Thermal Shutdown TSD2	T_{jTSD2_1}	170	185	200	°C	T_j rising; TSD_THR = 0	P_13.9.56
Thermal Shutdown TSD2 (high temp)	T_{jTSD2_2}	180	195	210	°C	T_j rising; TSD_THR = 1	P_13.9.61
Thermal Shutdown hysteresis	$T_{jTSD,hys}$	–	25	–	°C	–	P_13.9.57
TSD/TPW Filter Time	$t_{TSD_TPW_F}$	5	10	14	us	³⁾ rising and falling, applies to all thermal sensors (TPW, TSD1, TSD2)	P_13.9.58
Deactivation time after thermal shutdown TSD2	t_{TSD2}	0.8	1	1.2	s	³⁾	P_13.9.59

- 1) It is ensured that the threshold $V_{CC1,OV,r}$ is always higher than the highest regulated V_{CC1} output voltage $V_{CC1,out4}$.
- 2) The reset delay time starts when VCC1 crosses above the selected Vrtx threshold
- 3) Not subject to production test, tolerance defined by internal oscillator tolerance.
- 4) This time applies for all failure entries except a device thermal shutdown (TSD2 has a typ. 1s waiting time t_{TSD2})
- 5) Not subject to production test, specified by design.

Serial Peripheral Interface

13 Serial Peripheral Interface

The Serial Peripheral Interface is the communication link between the SBC and the microcontroller.

The TLE9461ES is supporting multi-slave operation in full-duplex mode with 16-bit data access.

The SPI behavior for the different SBC Modes is as follows:

- The SPI is enabled in SBC Init, Normal and Stop Mode
- The SPI is disabled in SBC Sleep, Restart and Fail-Safe Mode

13.1 SPI Block Description

The Control Input Word is read via the data input SDI, which is synchronized with the clock input CLK provided by the microcontroller. The output word appears synchronously at the data output SDO (see **Figure 39** with a 16-bit data access example).

The transmission cycle begins when the chip is selected by the input CSN (Chip Select Not), Low active. After the CSN input returns from Low to High, the word that has been read is interpreted according to the content. The SDO output switches to tristate status (high impedance) at this point, thereby releasing the SDO bus for other use. The state of SDI is shifted into the input register with every falling edge on CLK. The state of SDO is shifted out of the output register after every rising edge on CLK. The SPI of the SBC is not daisy chain capable.

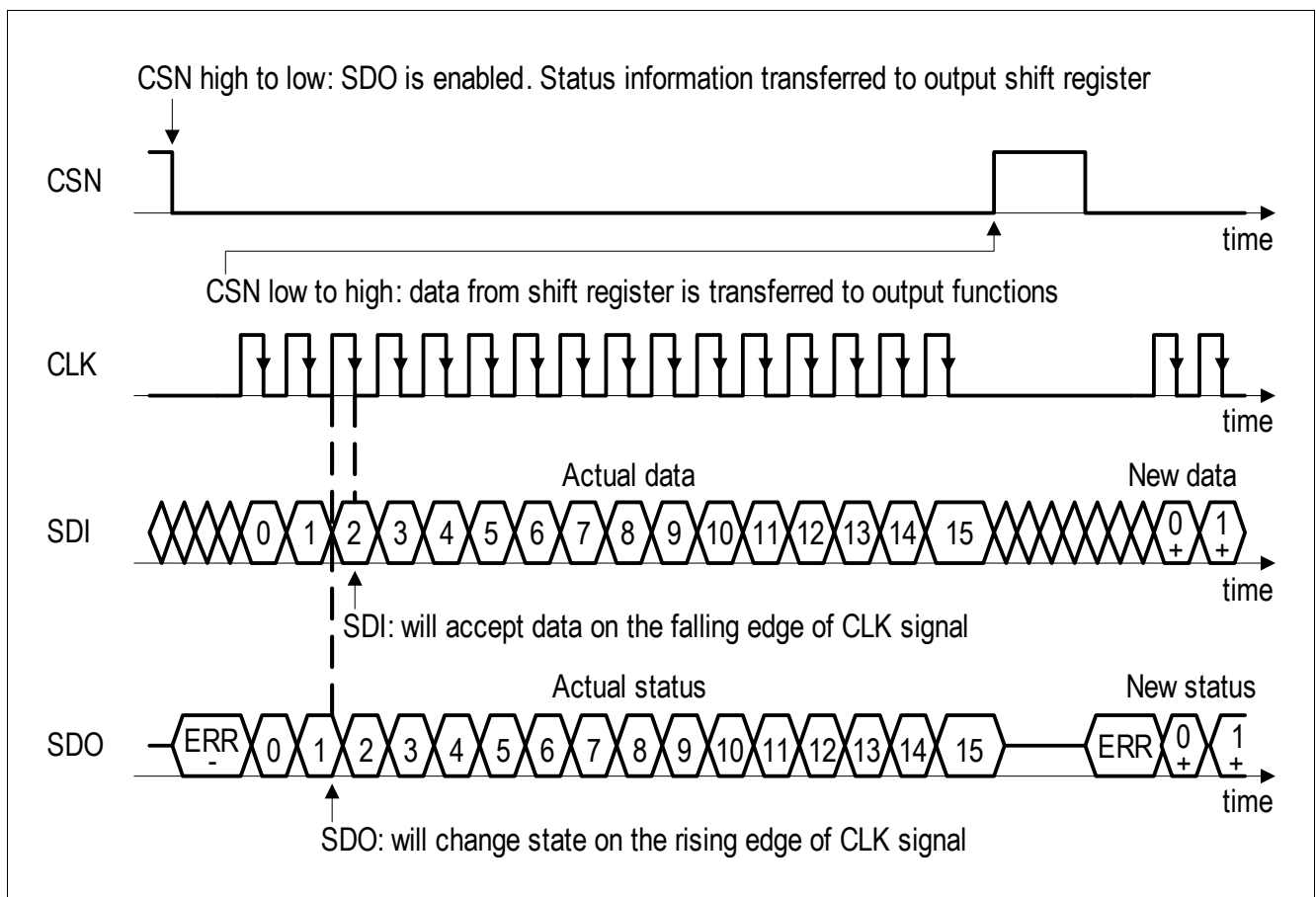

Figure 39 SPI Data Transfer Timing (note the reversed order of LSB and MSB shown in this figure compared to the register description)

13.2 Failure Signalization in the SPI Data Output

If the microcontroller sends a wrong SPI command to the SBC, the SBC ignores the information. Wrong SPI commands are either invalid SBC mode commands or commands which are prohibited by the state machine to avoid undesired device or system states (see below). In this case the diagnosis bit '**SPI_FAIL**' is set and the SPI Write command is ignored (mostly no partial interpretation). This bit can be only reset by actively clearing it via a SPI command.

Invalid SPI commands leading to **SPI_FAIL are listed below (in this case the SPI command is ignored):**

- Illegal state transitions:
 - Going from SBC Stop to SBC Sleep Mode. In this case the SBC enters SBC Restart Mode;
 - Trying to go to SBC Stop or SBC Sleep Mode from SBC Init Mode. In this case SBC Normal Mode is entered
- Uneven parity in the data bit of the **WD_CTRL** register. In this case the watchdog trigger is ignored and/or the new watchdog settings are ignored respectively
- In SBC Stop Mode: attempting to change any SPI settings, e.g. changing the watchdog configuration, PWM settings and HS configuration settings during SBC Stop Mode, etc.; the SPI command is ignored in this case;
only WD trigger, returning to Normal Mode, triggering a SBC Soft Reset, and Read & Clear status registers commands are valid SPI commands in SBC Stop Mode;
Note: No failure handling is done for the attempt to go to SBC STOP Mode when all bits in the registers **BUS_CTRL_0** and **WK_CTRL_1** are cleared because the microcontroller can leave this mode via SPI
- When entering SBC Stop Mode and **WK_STAT_0** and **WK_STAT_1** are not cleared; **SPI_FAIL** is not set but the INTN pin is triggered
- Changing from SBC Stop to Normal Mode and changing the other bits of the **M_S_CTRL** register. The other modifications are ignored
- SBC Sleep Mode: attempt to go to Sleep Mode without any wake source set, i.e. when all bits in the **BUS_CTRL_0**, **WK_CTRL_0**, **WK_CTRL_1** and **GPIO_CTRL** registers are cleared. In this case the **SPI_FAIL** bit is set and the device enters SBC Restart Mode.
Even though the Sleep Mode command is not entered in this case, the rest of the command (e.g. modifying VCC2) is executed but restart values apply during SBC Restart Mode;
Note: At least one wake source must be activated in order to avoid a deadlock situation in SBC Sleep Mode, i.e. the SBC would not be able to wake-up anymore.
If the only wake source is a timer and the timer is Off then the SBC will wake-up immediately from Sleep Mode and enter Restart Mode;
- Trying to set **WK_MEAS** when FO/GPIO is not Off, i.e. FO is activated/configured or any GPIO configuration is selected
- Trying to change the **GPIO_CTRL** settings in case **WK_MEAS** is set
- Setting a longer or equal On-time than the timer period of the respective timer
- SDI stuck at High or Low, e.g. SDI received all '0' or all '1'

Note: There is no SPI fail information for unused addresses.

Signalization of the ERR Flag (high active) in the SPI Data Output (see Figure 39):

The ERR flag presents an additional diagnosis possibility for the SPI communication. The ERR flag is being set for following conditions:

- in case the number of received SPI clocks is not 0 or 16
- in case RSTN is Low and SPI frames are being sent at the same time.

Serial Peripheral Interface

Note: In order to read the SPI ERR flag properly, CLK must be Low when CSN is triggered, i.e. the ERR bit is not valid if the CLK is High on a falling edge of CSN

The number of received SPI clocks is not 0, 16 or 32:

The number of received input clocks is supervised to be 0 or 16 clock cycles and the input word is discarded in case of a mismatch (0 clock cycle to enable ERR signalization). The error logic also recognizes if CLK was High during CSN edges. Both errors - 0 or 16 bit CLK mismatch or CLK High during CSN edges - are flagged in the following SPI output by a “High” at the data output (SDO pin, bit ERR) before the first rising edge of the clock is received. The complete SPI command is ignored in this case.

RSTN is Low and SPI frames are being sent at the same time:

The ERR flag is set when the RSTN pin is triggered (during SBC Restart) and SPI frames are being sent to the SBC at the same time. The behavior of the ERR flag is signalized at the next SPI command for below conditions:

- if the command begins when RSTN is High and it ends when RSTN is Low,
- if a SPI command is sent while RSTN is Low,
- If a SPI command begins when RSTN is Low and it ends when RSTN is High.

and the SDO output behaves as follows:

- always when RSTN is Low then SDO is High,
- when a SPI command begins with RSTN is Low and ends when RSTN is High, then the SDO should be ignored because wrong data is sent.

Note: It is possible to quickly check for the ERR flag without sending any data bits. i.e. only the CSN is pulled Low and SDO is observed - no SPI Clocks are sent in this case

Note: The ERR flag could also be set after the SBC has entered SBC Fail-Safe Mode because the SPI communication is stopped immediately.

13.3 SPI Programming

For the TLE9461ES, 7 bits are used for the address selection (BIT6...0). Bit 7 is used to decide between Read Only and Read & Clear for the status bits, and between Write and Read Only for configuration bits. For the actual configuration and status information, 8 data bits (BIT15...8) are used.

Writing, clearing and reading is done byte wise. The SPI status bits are not cleared automatically and must be cleared by the microcontroller, e.g. if the TSD2 was set due to over temperature. Some of the configuration bits will automatically be cleared by the SBC - please refer to the respective register descriptions for detailed information. In SBC Restart Mode, the device ignores all SPI communication, i.e. it does not interpret it.

There are two types of SPI registers:

- Control registers: These registers are used to configure the SBC, e.g. SBC mode, watchdog trigger, etc.
- Status registers: These registers indicate the status of the SBC, e.g. wake-up events, warnings, failures, etc.

For the status registers, the requested information is given in the same SPI command in the data out (SDO). For the control registers, the status of each byte is shown in the same SPI command as well. However, configuration changes of the same register are only shown in the next SPI command (configuration changes inside the SBC become valid only after CSN changes from Low to High).

Writing of control registers is possible in SBC Init and Normal Mode. During SBC Stop Mode only the change to SBC Normal Mode and triggering the watchdog is allowed as well as reading and clearing the status registers.

Serial Peripheral Interface

Certain SPI control bits used to configure device functionality can be locked to avoid unintentional bit modification. The respective bit type is 'rwl'. There are two levels of configuration locks:

- **CFG_LOCK_0** in the **HW_CTRL_1** is the level 0 lock mechanism: The bits **CP_EN** and **GPIO** can be locked. In case the configuration must be changed then **CFG_LOCK_0** must be cleared first
- **CFG_LOCK_1** in the **HW_CTRL_2** is the level 1 lock mechanism: All other lockable bits with the type 'rwl' are locked and can only be modified at the next device power up

No status information can be lost, even if a bit changes right after the first 7 SPI clock cycles before the SPI frame ends. In this case the status information field is updated with the next SPI command. However, the flag is already set in the relevant status register.

The SBC status information from the SPI status registers is transmitted in a compressed format with each SPI response on SDO in the so-called Status Information Field register (see also **Figure 40**). The purpose of this register is to quickly signal changes in the SPI status registers to the microcontroller. This means that the microcontroller only needs to read registers which have changed.

Each bit in the Status Information Field represents a SPI status register (see **Table 26**). As soon as one bit is set in one of the status registers, the corresponding bit in the Status Information Field register is set. Only the most important registers are represented in the Status Information Field, e.g. the register **WK_LVL_STAT** is not included.

For example if bit 0 in the Status Information Field is set to '1', one or more bits of the register 100 0001 (**SUP_STAT_0**) are set to 1. Then this register needs to be read with a second SPI command. The bit in the Status Information Field is set to 0 when all bits in the register 100 0001 have been reset to '0'.

Table 26 Status Information Field

Bit in Status Information Field	Corresponding Address Bit	Status Register Description
0	100 0001	SUP_STAT_0 - Supply Status: POR, VCC2 fail, VCC1 fail
1	100 0010	THERM_STAT - Thermal Protection Status
2	100 0011	DEV_STAT- Device Status: Mode before wake-up-up/failure, WD Fail, SPI Fail, Failure
3	100 0100	BUS_STAT - Bus Failure Status: CAN;
4	100 0110 100 0111	WK_STAT_0, WK_STAT_1 - Wake Source Status; Status bit is a combinational OR of both registers
5	100 0000	SUP_STAT_1: VS_UV, VCC1_WARN/OV
6	101 0100	GPIO_OC_STAT: GPIO over current
7	101 0101	GPIO_OL_STAT: GPIO open load

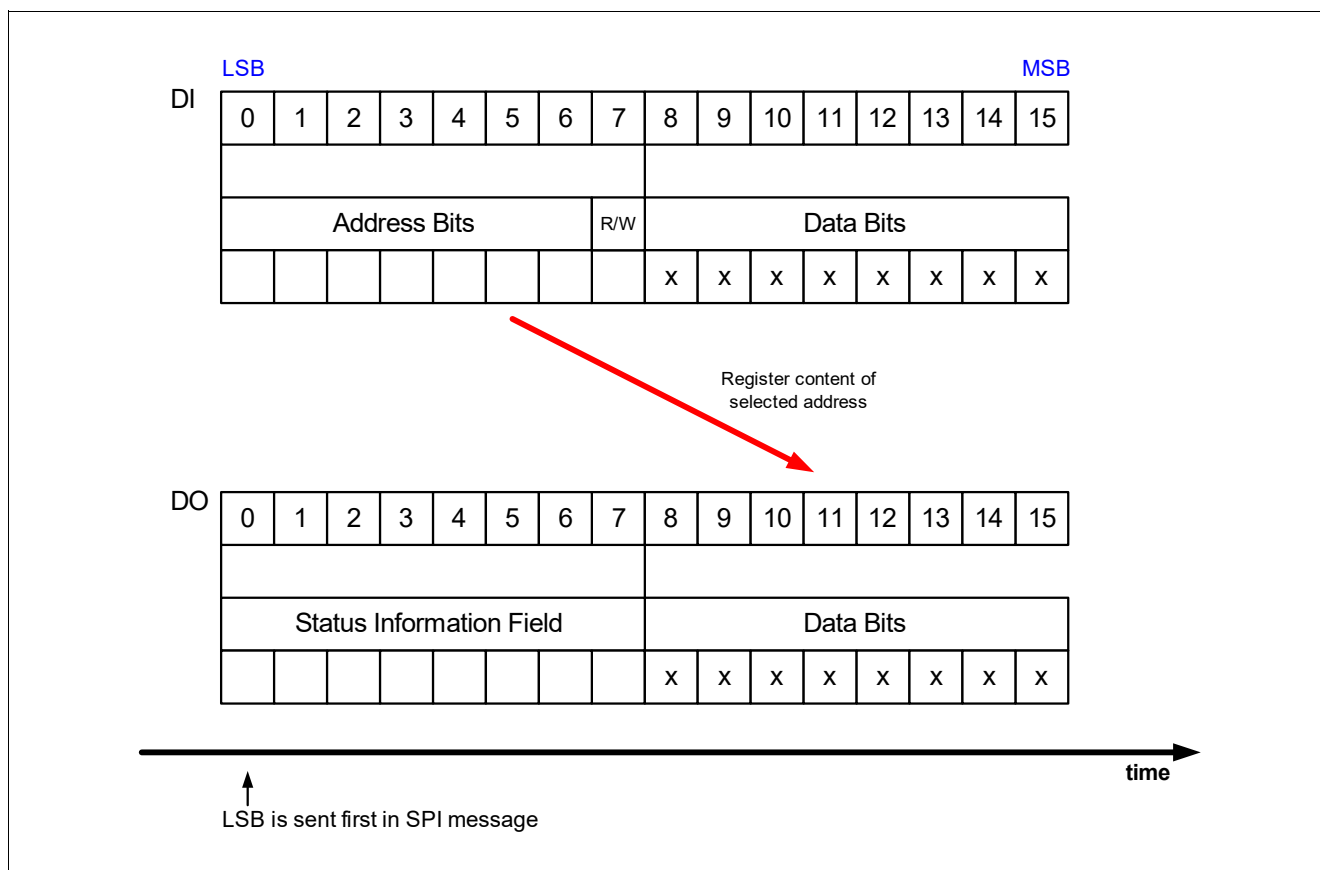

Figure 40 SPI Operation Mode

13.4 SPI Bit Mapping

The following figures show the mapping of the registers and the SPI bits of the respective registers.

The Control Registers '000 0000' to '001 1110' are Read/Write Register. Depending on bit 7 the bits are only read (setting bit 7 to '0') or also written (setting bit 7 to '1'). The new setting of the bit after a write can be seen with a new read / write command.

The registers '100 0000' to '111 1110' are Status Registers and can be read or read with clearing the bit (if possible) depending on bit 7. To clear a Data Byte of one of the Status Registers bit 7 must be set to '1'. The registers **WK_LVL_STAT**, and **FAM_PROD_STAT** are an exception as they show the actual voltage level at the respective WK pin (Low/High), or a fixed family/ product ID respectively and can thus not be cleared. It is recommended for proper diagnosis to clear respective status bits for wake-up events or failure. However, in general it is possible to enable drivers without clearing the respective failure flags.

When changing to a different SBC Mode, certain configurations bits is cleared automatically or modified:

- The SBC Mode bits are updated to the actual status, e.g. when returning to Normal Mode
- When changing to a low-power mode (Stop/Sleep), the diagnosis bits of the switches and transceivers are not cleared. FO will stay activated if it was triggered before.
- When changing to SBC Stop Mode, the CAN control bits will not be modified.
- When changing to SBC Sleep Mode, the CAN control bits is modified if they were not Off or Wake Capable before.
- VCC2 will stay On when going to Sleep-/Stop Mode (configuration can only be done in Normal Mode). Diagnosis is active. In case of a failure the regulator is turned Off and no wake-up is issued.

Serial Peripheral Interface

- The configuration bits for VCC2 in stand-alone configuration are cleared in SBC Restart Mode. FO will stay activated if it was triggered before. Depending on the respective configuration, CAN transceivers is either Off, woken or still Wake Capable.

Note: The detailed behavior of the respective SPI bits and control functions is described in [Chapter 13.5](#), [Chapter 13.6](#) and in the respective module chapter. The bit type be marked as 'rwh' in case the SBC will modify respective control bits.

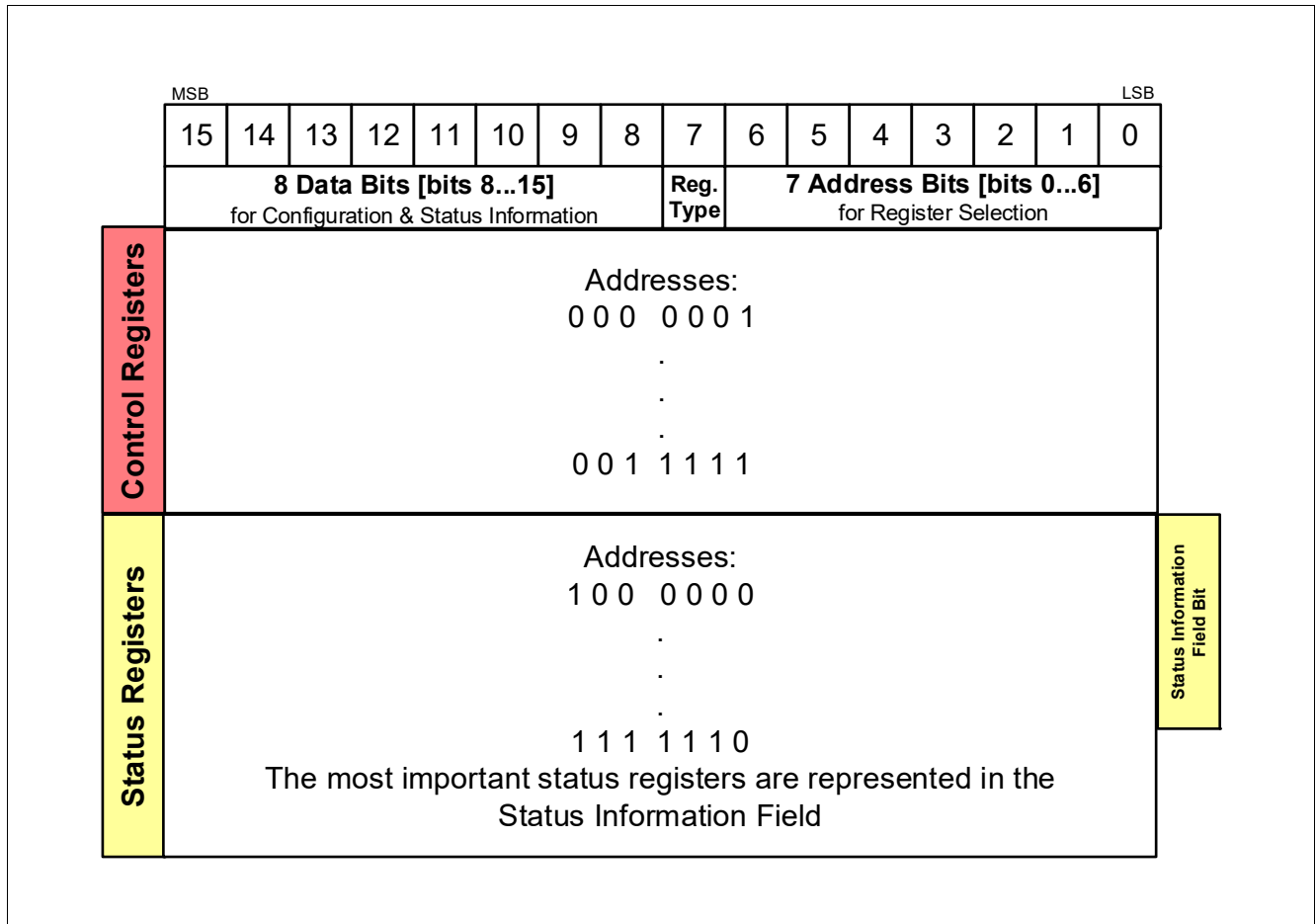

Figure 41 SPI Register Mapping Structure

The detailed register mappings for control registers and status registers are shown in [Table 27](#) and [Table 28](#) respectively.

The detailed SPI bit mapping overview is shown in [Figure 42](#).

Serial Peripheral Interface

Register Short Name	15	14	13	12	11	10	9	8	7	6..0	
	Data Bit 15..8									Access Mode	Address A6..A0
	D7	D6	D5	D4	D3	D2	D1	D0			
CONTROL REGISTERS											
M_S_CTRL	MODE 1	MODE 0	reserved	VCC2_ON 1	VCC2_ON 0	VCC1_OV_RST	VCC1_RT 1	VCC1_RT 0	read/write	000001	
HW_CTRL_0	reserved	OFT RESET_RST	FO_ON	reserved	reserved	CP_EN	reserved	CFG1	read/write	000010	
WD_CTRL	CHECKSUM	WD_STM_EN 0	WD_WIN	WD_EN_WK_BUS	reserved	WD_TIMER 2	WD_TIMER 1	WD_TIMER 0	read/write	000011	
BUS_CTRL_0	reserved	reserved	reserved	reserved	reserved	reserved	CAN 1	CAN 0	read/write	000100	
WK_CTRL_0	reserved	TIMER_WK_EN	reserved	reserved	reserved	WD_STM_EN 1	reserved	reserved	read/write	000110	
WK_CTRL_1	INT_GLOBAL	reserved	WK_MEAS	reserved	reserved	reserved	reserved	WK_EN	read/write	000111	
WK_PUPD_CTRL	GPIO_WK_PUPD_1	GPIO_WK_PUPD_0	reserved	reserved	reserved	reserved	reserved	WK_PUPD_1	read/write	0001000	
BUS_CTRL_3	reserved	reserved	reserved	CAN_FLASH	reserved	reserved	reserved	reserved	read/write	0001011	
TIMER_CTRL	reserved	TIMER_ON 2	TIMER_ON 1	TIMER_ON 0	TIMER_PER 3	TIMER_PER 2	TIMER_PER 1	TIMER_PER 0	read/write	0001100	
HW_CTRL_1	RSTN_HYS	reserved	TSD2_DEL	RSTN_DEL	CFG_LOCK_0	reserved	reserved	reserved	read/write	0001110	
HW_CTRL_2	2MHZ_FREQ 2	2MHZ_FREQ 1	2MHZ_FREQ 0	I_PEAK_TH	SS_MOD_FR 1	SS_MOD_FR 0	reserved	CFG_LOCK_1	read/write	0001111	
GPIO_CTRL	reserved	reserved	reserved	reserved	reserved	GPIO_2	GPIO_1	GPIO_0	read/write	0010111	
PWM_CTRL	PWM_DC 7	PWM_DC 6	PWM_DC 5	PWM_DC 4	PWM_DC 3	PWM_DC 2	PWM_DC 1	PWM_DC 0	read/write	0011000	
PWM_FREQ_CTRL	reserved	reserved	reserved	reserved	reserved	reserved	PWM_FREQ 1	PWM_FREQ 0	read/write	0011100	
HW_CTRL_3	reserved	reserved	reserved	reserved	reserved	TSD_THR	ICC1_LIM_ADJ 1	ICC1_LIM_ADJ 0	read/write	0011101	
SYS_STAT_CTRL_0	SYS_STAT 7	SYS_STAT 6	SYS_STAT 5	SYS_STAT 4	SYS_STAT 3	SYS_STAT 2	SYS_STAT 1	SYS_STAT 0	read/write	0011110	
SYS_STAT_CTRL_1	SYS_STAT 15	SYS_STAT 14	SYS_STAT 13	SYS_STAT 12	SYS_STAT 11	SYS_STAT 10	SYS_STAT 9	SYS_STAT 8	read/write	0011111	
STATUS REGISTERS											
SUP_STAT_1	reserved	VS_UV	VS_OV	reserved	reserved	reserved	VCC1_OV	VCC1_WARN	read/clear	1000000	
SUP_STAT_0	POR	reserved	reserved	VCC2_OT	VCC2_UV	VCC1_SC	reserved	VCC1_UV	read/clear	1000001	
THERM_STAT	reserved	reserved	reserved	reserved	TSD2_SAFE	TSD1	TPW	reserved	read/clear	1000010	
DEV_STAT	DEV_STAT 1	DEV_STAT 0	reserved	reserved	WD_FAIL 1	WD_FAIL 0	SPI_FAIL	FAILURE	read/clear	1000011	
BUS_STAT	reserved	reserved	reserved	r	reserved	CAN_FAIL 1	CAN_FAIL 0	VCAN_UV	read/clear	1000100	
WK_STAT_0	reserved	reserved	CAN_WU	TIMER_WU	reserved	reserved	reserved	WK_WU	read/clear	1000110	
WK_STAT_1	reserved	reserved	reserved	GPIO_WK_WU	reserved	reserved	reserved	reserved	read/clear	1000111	
WK_LVL_STAT	SBC_DEV_LVL	CFG0_STATE	reserved	GPIO_LVL	reserved	reserved	reserved	WK_LVL	read	1001000	
GPIO_OC_STAT	reserved	GPIO_HS_LS_OC	reserved	reserved	reserved	reserved	reserved	reserved	read/clear	1010100	
GPIO_OL_STAT	reserved	GPIO_HS_OL	reserved	reserved	reserved	reserved	reserved	reserved	read/clear	1010101	
FAMILY AND PRODUCT REGISTERS											
FAM_PROD_STAT	FAM 3	FAM 2	FAM 1	FAM 0	PROD 3	PROD 2	PROD 1	PROD 0	read	1111110	

Figure 42 Detailed TLE9461ES SPI Bit Mapping

13.5 SPI Control Registers

READ/WRITE Operation (see also [Chapter 13.3](#)):

- The 'POR / Soft Reset Value' defines the register content after POR or SBC Reset.
 - The 'Restart Value' defines the register content after SBC Restart, where 'x' means the bit is unchanged.
 - One 16-bit SPI command consist of two bytes:
 - the 7-bit address and one additional bit for the register access mode and
 - following the data byte
- The numbering of following bit definitions refers to the data byte and correspond to the bits D0...D7 and to the SPI bits 8...15.
- There are four different bit types:
 - 'r' = READ: read only bits (or reserved bits)
 - 'rw' = READ/WRITE: readable and writable bits
 - 'rwh' = READ/WRITE/Hardware: readable/writable bits, which can also be modified by the SBC hardware
 - 'rwl' = READ/WRITE/LOCKED: readable/writable bits, which are locked and cannot be modified anymore once the bit [CFG_LOCK_0](#) in the [HW_CTRL_1](#) or [CFG_LOCK_1](#) in the [HW_CTRL_2](#) register are set. The locking mechanism will remain active for all conditions (incl. Soft Reset) unless the bit [CFG_LOCK_0](#) (for [CP_EN](#) or [GPIO](#) only) is cleared again;
for bits relating to [CFG_LOCK_1](#) the locking mechanism will remain active until the device is powered down ($V_S < V_{POR,f}$) and can only be changed at the next device power-up.
After a soft reset command: If the respective lock bit is not set then the POR values are resumed; if the respective lock bit is set then the respective configurations stay unchanged, i.e. the soft reset has no effect on those configurations.
 - Reserved bits are marked as "Reserved" and always read as "0". The respective bits shall also be programmed as "0".
 - Reading a register is done byte wise by setting the SPI bit 7 to "0" (= Read Only).
 - Writing to a register is done byte wise by setting the SPI bit 7 to "1".
 - SPI control bits are in general not cleared or changed automatically. This must be done by the microcontroller via SPI programming. Exceptions to this behavior are stated at the respective register description and the respective bit type is marked with a 'h' meaning that the SBC is able to change the register content.

The registers are addressed wordwise.

Serial Peripheral Interface

Table 27 Register Overview: SPI Control Register

Register Short Name	Register Long Name	Offset Address	Reset Value
General Control Registers			
M_S_CTRL	Mode- and Supply Control	000 0001 _B	Page 106
HW_CTRL_0	Hardware Control 0	000 0010 _B	Page 107
WD_CTRL	Watchdog Control	000 0011 _B	Page 108
BUS_CTRL_0	Bus Control 0	000 0100 _B	Page 109
WK_CTRL_0	Internal Wake Input Control	000 0110 _B	Page 109
WK_CTRL_1	External Wake Source Control	000 0111 _B	Page 110
WK_PUPD_CTRL	Wake Input Level Control	000 1000 _B	Page 111
BUS_CTRL_3	Bus Control 3	000 1011 _B	Page 111
TIMER_CTRL	Timer Control and Selection	000 1100 _B	Page 112
HW_CTRL_1	Hardware Control 1	000 1110 _B	Page 113
HW_CTRL_2	Hardware Control 2	000 1111 _B	Page 114
GPIO_CTRL	GPIO Configuration Control	001 0111 _B	Page 115
PWM_CTRL	PWM Configuration Control	001 1000 _B	Page 115
PWM_FREQ_CTRL	PWM Frequency Configuration Control	001 1100 _B	Page 116
HW_CTRL_3	Hardware Control 3	001 1101 _B	Page 116
SYS_STATUS_CTRL_0	System Status Control Low Byte	001 1110 _B	Page 117
SYS_STATUS_CTRL_1	System Status Control High Byte	001 1111 _B	Page 117

Serial Peripheral Interface

13.5.1 General Control Registers

M_S_CTRL

Mode- and Supply Control (Address 000 0001_B)

POR / Soft Reset Value: 0000 0000_B; Restart Value: 0000 00xx_B

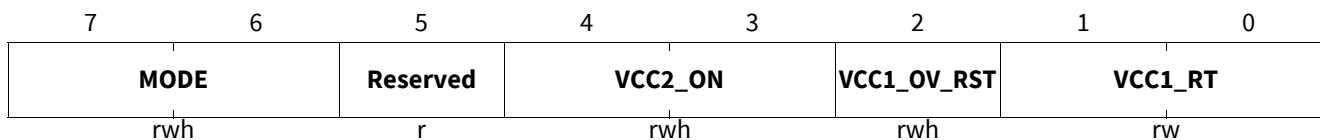

Field	Bits	Type	Description
MODE	7:6	rwh	SBC Mode Control 00 _B , SBC Normal Mode 01 _B , SBC Sleep Mode 10 _B , SBC Stop Mode 11 _B , SBC Reset: Soft Reset is executed (configuration of RSTN triggering in bit SOFT_RESET_RST)
Reserved	5	r	Reserved, always reads as 0
VCC2_ON	4:3	rwh	VCC2 Mode Control 00 _B , VCC2 Off 01 _B , VCC2 On in Normal Mode 10 _B , VCC2 On in Normal and Stop Mode 11 _B , VCC2 always On (except in SBC Init - if not in SBC Development Mode, SBC Restart and Fail-Safe Mode)
VCC1_OV_RST	2	rwh	VCC1 Over Voltage leading to Restart / Fail-Safe Mode enable 0 _B , VCC1_OV is set in case of VCC1_OV; no SBC Restart or Fail-Safe is entered for VCC1_OV 1 _B , VCC1_OV is set in case of VCC1_OV; depending on the device configuration SBC Restart or SBC Fail-Safe Mode is entered (see Chapter 5.1.1);
VCC1_RT	1:0	rw	VCC1 Reset Threshold Control 00 _B , Vrt1 selected (highest threshold) 01 _B , Vrt2 selected 10 _B , Vrt3 selected 11 _B , Vrt4 selected

Notes

1. It is not possible to change from Stop to Sleep Mode via SPI Command. See also the State Machine Chapter
2. In a transition from SBC Stop to SBC Normal Mode a change of the bits [4:0] is ignored and the SPI_FAIL bit is set. The transition to SBC Normal Mode is executed.
3. After entering SBC Restart Mode, the MODE bits is automatically set to SBC Normal Mode. The VCC2_ON bits is automatically set to Off after entering SBC Restart Mode and after over temperature (OT).
4. The SPI output will always show the previously written state with a Write Command (what has been programmed before)
5. When in SBC Development Mode the POR/Soft Reset value of VCC2_ON = '11', i.e. VCC2 is On in SBC Init Mode but is switched Off with a Soft Reset command

Serial Peripheral Interface

HW_CTRL_0

Hardware Control 0 (Address 000 0010_B)

POR / Soft Reset Value: 0y00 0y00_B; Restart Value: 0x00 0x0x_B

7	6	5	4	3	2	1	0
Reserved	SOFT_RESET _RST	FO_ON	Reserved		CP_EN	Reserved	CFG1
r	rwl	rwh	r		rwl	r	rw

Field	Bits	Type	Description
Reserved	7	r	Reserved, always reads as 0
SOFT_RESE T_RST	6	rwl	Soft Reset Configuration 0 _B , RST is triggered (pulled Low) during a Soft Reset 1 _B , no RST trigger during a Soft Reset
FO_ON	5	rwh	Failure Output Activation 0 _B , FO not activated by software, FO is activated by specified failures (see Chapter 11.1.1) 1 _B , FO activated by software (via SPI), only if configured as FO
Reserved	4:3	r	Reserved, always reads as 0
CP_EN	2	rwl	Charge Pump Output Enable 0 _B , Charge Pump is Off 1 _B , Charge Pump Output is enabled (see Chapter 5)
Reserved	1	r	Reserved, always reads as 0
CFG1	0	rw	Configuration Select 1 (see also Table 5) 0 _B , Depending on hardware configuration, SBC Restart or Fail-Safe Mode is reached after the 2. watchdog trigger failure (=default) - Config 3/4 1 _B , Depending on hardware configuration, SBC Restart or Fail-Safe Mode is reached after the 1. watchdog trigger failure - Config 1/2

Notes

1. Clearing the **FO_ON** bit will not disable the FO output in case a failure occurred which triggered the FO output. In this case the FO output have to be disabled by clearing the **FAILURE** bit.
If the **FO_ON** bit is set by the software then it is cleared by the SBC after SBC Restart Mode was entered and the FO output is disabled (if no failures occurred which triggered the fail outputs). See also [Chapter 11](#) for FO activation and deactivation.
2. In case the **CFG_LOCK_1** bit is set, then the soft reset value for **SOFT_RESET_RST** will stay unchanged, i.e. 'x'; the same applies if **CFG_LOCK_0** is set: then the soft reset value of the bit **CP_EN** will stay unchanged, i.e. 'x'. Therefore, the respective soft reset values are marked as 'y'.

Serial Peripheral Interface

WD_CTRL

Watchdog Control (Address 000 0011_B)

POR / Soft Reset Value: 0001 0100_B; Restart Value: x0xx 0100_B

7	6	5	4	3	2	1	0
CHECKSUM	WD_STM_EN_0	WD_WIN	WD_EN_WK_BUS	Reserved	WD_TIMER		
rw	rwh	rw	rw	r	rwh		

Field	Bits	Type	Description
CHECKSUM	7	rw	Watchdog Setting Check Sum Bit The sum of bits 7:0 needs to have even parity (see Chapter 12.2.3) 0 _B , Counts as 0 for checksum calculation 1 _B , Counts as 1 for checksum calculation
WD_STM_EN_0	6	rwh	Watchdog Deactivation during Stop Mode, bit 0 (Chapter 12.2.4) 0 _B , Watchdog is active in Stop Mode 1 _B , Watchdog is deactivated in Stop Mode
WD_WIN	5	rw	Watchdog Type Selection 0 _B , Watchdog works as a Time-Out watchdog 1 _B , Watchdog works as a Window watchdog
WD_EN_WK_BUS	4	rw	Watchdog Enable after Bus (CAN) Wake-up in SBC Stop Mode 0 _B , Watchdog will not start after a CAN wake-up 1 _B , Watchdog starts with a long open window after CAN Wake
Reserved	3	r	Reserved, always reads as 0
WD_TIMER	2:0	rwh	Watchdog Timer Period 000 _B , 10ms 001 _B , 20ms 010 _B , 50ms 011 _B , 100ms 100 _B , 200ms 101 _B , 500ms 110 _B , 1000ms 111 _B , 10000ms

Notes

1. See also [Chapter 12.2.4](#) for more information on disabling the watchdog in SBC Stop Mode.
2. See [Chapter 12.2.5](#) for more information on the effect of the bit WD_EN_WK_BUS.
3. See [Chapter 12.2.3](#) for calculation of checksum.

Serial Peripheral Interface

BUS_CTRL_0

Bus Control 0 (Address 000 0100_B)

POR / Soft Reset Value: 0000 0000_B; Restart Value: 0000 00yy_B

7	6	5	4	3	2	1	0
Reserved						CAN	
r						rwh	

Field	Bits	Type	Description
Reserved	7:2	r	Reserved, always reads as 0
CAN	1:0	rwh	HS-CAN Module Modes 00 _B , CAN Off 01 _B , CAN is Wake Capable 10 _B , CAN Receive Only Mode 11 _B , CAN Normal Mode

Notes

1. The reset values for the CAN transceivers are marked with 'y' because they will vary depending on the cause of change - see below.
2. see [Figure 19](#) for detailed state changes of CAN Transceiver for different SBC modes.
3. Failure Handling Mechanism: When the device enters Fail-Safe Mode due to a failure (TSD2, WD-Failure,...), then **BUS_CTRL_0** is modified by the SBC to '0000 0001' to ensure that the device can be woken again. See also the description of **WK_CTRL_1** for other wake sources when entering SBC Fail-Safe Mode.
4. When in SBC Development Mode the POR/Soft Reset value of CAN = '011'

WK_CTRL_0

Internal Wake Input Control (Address 000 0110_B)

POR / Soft Reset Value: 0000 0000_B; Restart Value: 0x00 0000_B

7	6	5	4	3	2	1	0
Reserved	TIMER_WK_EN	Reserved		WD_STM_EN_1		Reserved	
r	rw	r		rwh		r	

Field	Bits	Type	Description
Reserved	7	r	Reserved, always reads as 0
TIMER_WK_EN	6	rw	Timer Wake Source Control (for Cyclic Wake) 0 _B , Timer wake-up disabled 1 _B , Timer is enabled as a wake source
Reserved	5:3	r	Reserved, always reads as 0
WD_STM_EN_1	2	rwh	Watchdog Deactivation during Stop Mode, bit 1 (Chapter 12.2.4) 0 _B , Watchdog is active in Stop Mode 1 _B , Watchdog is deactivated in Stop Mode
Reserved	1:0	r	Reserved, always reads as 0

Note: **WD_STM_EN_1** will also be cleared when changing from SBC Stop to Normal Mode

Serial Peripheral Interface

WK_CTRL_1

External Wake Source Control (Address 000 0111_B)

POR / Soft Reset Value: 0000 0001_B; Restart Value: x0x0 000x_B

7	6	5	4	3	2	1	0
INT_GLOBAL	Reserved	WK_MEAS	Reserved			WK_EN	
rw	r	rw	r			rw	

Field	Bits	Type	Description
INT_GLOBAL	7	rw	Global Interrupt Configuration (see also Chapter 10.1) 0 _B , Only wake sources trigger INTN (default) 1 _B , All status information register bits will trigger INTN (including all wake sources)
Reserved	6	r	Reserved, always reads as 0
WK_MEAS	5	rw	Wake / Voltage Sensing Selection (see also Chapter 9.2.4) 0 _B , Wake-up functionality enabled for WK 1 _B , Voltage sensing functionality enabled, no wake-up events are generated
Reserved	4:1	r	Reserved, always reads as 0
WK_EN	0	rw	WK Wake Source Control 0 _B , WK wake-up disabled 1 _B , WK is enabled as a wake source

Notes

1. *WK_MEAS* is by default configured for standard WK functionality (Static Sense on WK). If *WK_MEAS* is set and *FO* is not activated then the bits *WK_EN* and *GPIO_CTRL* are ignored. If *FO* is activated then *WK_MEAS* cannot be set to '1' and *SPI_Fail* is set. If the bit is set to '1' then the measurement function is enabled during Normal Mode & the bits *WK_EN* are ignored. The bits *WK_LVL* and *GPIO_LVL* bits are not updated and are reset.
2. The wake source CAN is selected in the register **BUS_CTRL_0** by setting the respective bits to 'Wake Capable'
3. Failure Handling Mechanism: When the device enters SBC Fail-Safe Mode due to a failure (TSD2, WD-Failure,...) and *WK_MEAS* = '0', the **WK_CTRL_1** is modified by the SBC to 'x0x0 0001' in order to ensure that the device can be woken again. In case *WK_MEAS* is '1' then WK will not be available as an automatic wake source in SBC Fail-Safe Mode.

Serial Peripheral Interface

WK_PUPD_CTRL

Wake Input Level Control (Address 000 1000_B)

POR / Soft Reset Value: 0000 0000_B; Restart Value: xx00 00xx_B

7	6	5	4	3	2	1	0
GPIO_WK_PUPD		Reserved				WK_PUPD	
rw		r				rw	

Field	Bits	Type	Description
GPIO_WK_PUPD	7:6	rw	GPIO WK Pull-Up / Pull-Down Configuration (only if GPIO configured as WK) 00 _B , No pull-up / pull-down selected 01 _B , Pull-down resistor selected 10 _B , Pull-up resistor selected 11 _B , Automatic switching to pull-up or pull-down
Reserved	5:2	r	Reserved, always reads as 0
WK_PUPD	1:0	rw	WK Pull-Up / Pull-Down Configuration 00 _B , No pull-up / pull-down selected 01 _B , Pull-down resistor selected 10 _B , Pull-up resistor selected 11 _B , Automatic switching to pull-up or pull-down

BUS_CTRL_3

Bus Control 3 (Address 000 1011_B)

POR / Soft Reset Value: 0000 0000_B; Restart Value: 000x 0000_B

7	6	5	4	3	2	1	0
Reserved			CAN_Flash	Reserved			
r			rw	r			

Field	Bits	Type	Description
Reserved	7:5	r	Reserved, always reads as 0
CAN_Flash	4	rw	HS-CAN Flash Mode Activation 0 _B , Flash Mode disabled: CAN communication up to 5MBaud 1 _B , Flash Mode enabled: CAN communication for higher than 5MBaud (higher emission on CAN bus - no slew rate control)
Reserved	3:0	r	Reserved, always reads as 0

Note: The electrical parameters for the CAN FD communication are ensured up to 5MBaud for the default setting (**CAN_Flash** is cleared). In case higher communication rates are required then **CAN_Flash** can be set.

Serial Peripheral Interface

TIMER_CTRL

Timer Control and Selection (Address 000 1100_B)

POR / Soft Reset Value: 0000 0000_B; Restart Value: 0000 0000_B

7	6	5	4	3	2	1	0
Reserved	TIMER_ON			TIMER_PER			
r	rwh			rwh			

Field	Bits	Type	Description
Reserved	7	r	Reserved, always reads as 0
TIMER_ON	6:4	rwh	Timer On-Time Configuration 000 _B , Off / Low (timer not running, HSx output is Low) 001 _B , 0.1ms On-time 010 _B , 0.3ms On-time 011 _B , 1.0ms On-time 100 _B , 10ms On-time 101 _B , 20ms On-time 110 _B , Off / High (timer not running, HSx output is High) 111 _B , reserved
TIMER_PER	3:0	rwh	Timer Period Configuration 0000 _B , 10ms 0001 _B , 20ms 0010 _B , 50ms 0011 _B , 100ms 0100 _B , 200ms 0101 _B , 500ms 0110 _B , 1s 0111 _B , 2s 1000 _B , 5s 1001 _B , 10s 1010 _B , 20s 1011 _B , 50s 1100 _B , 100s 1101 _B , 200s 1110 _B , 500s 1111 _B , 1000s

Notes

1. The timer must be first assigned and is then automatically activated as soon as the On-time is configured.
2. If Cyclic Sense is selected and the GPIO HS switch is cleared during SBC Restart Mode then also the timer settings (period and On-time) are cleared to avoid incorrect switch detection. However, the timer settings are not cleared in case of failure not leading to SBC Restart Mode. This must be considered by the application.
3. in case the timer is set as wake sources and Cyclic Sense is running, then both Cyclic Sense and Cyclic Wake are active at the same time.
4. A new timer configuration will become active immediately, i.e. as soon as CSN goes High.

Serial Peripheral Interface

HW_CTRL_1

Hardware Control 1 (Address 000 1110_B)

POR / Soft Reset Value: y0yy y000_B; Restart Value: x0xx x000_B

7	6	5	4	3	2	1	0
RSTN_HYS	Reserved	TSD2_DEL	RSTN_DEL	CFG_LOCK_0	Reserved		
rwl	r	rwl	rwl	rw	r		

Field	Bits	Type	Description
RSTN_HYS	7	rwl	VCC1 Undervoltage Reset Hysteresis Selection (see also Chapter 12.5.1 for more information) 0 _B , default hysteresis applies as specified in the electrical characteristics table 1 _B , the highest rising threshold (Vrt1,r) is always used for the release of the undervoltage reset
Reserved	6	r	Reserved, always reads as 0
TSD2_DEL	5	rwl	TSD2 Minimum Waiting Time Selection 0 _B , Minimum waiting time until TSD2 is released again is always 1s 1 _B , Minimum waiting time until TSD2 is released again is 1s, after >16 consecutive TSD2 events, it is extended to x64
RSTN_DEL	4	rwl	Reset Delay Time Selection 0 _B , The extended reset delay time t_{RD1} is selected (default) 1 _B , The reduced t_{RD2} reset delay time is selected
CFG_LOCK_0	3	rw	Configuration Lock Bit - Level 0 0 _B , CP_EN and GPIO can be modified 1 _B , CP_EN and GPIO is locked and cannot be modified
Reserved	2:0	r	Reserved, always reads as 0

Notes

1. See also [Chapter 12.5](#) for selection of VCC1 undervoltage hysteresis
2. See also [Chapter 12.8](#) for minimum waiting time in case of an TSD2 event
3. The bit **CFG_LOCK_0** is used to prevent an unintentional modification of the charge pump activation bit **CP_EN** and the GPIO configuration bits **GPIO**. In case the charge pump output state or the GPIO configuration must be changed then it is necessary to clear **CFG_LOCK_0**. The other lockable bits are controlled by the lock bit **CFG_LOCK_1**. In case either lock bit is set then the respective locked bits cannot be changed by a soft reset. Therefore, the respective soft reset values are marked as 'y'.
4. In case **CFG_LOCK_1** bit are set, then the respective soft reset value is like the Restart value.

Serial Peripheral Interface

HW_CTRL_2

Hardware Control 2 (Address 000 1111_B)

POR Value: 0100 0000_B; Restart Value/Soft Reset Value: xxxx xx0x_B

7	6	5	4	3	2	1	0
2MHZ_FREQ		I_PEAK_TH		SS_MOD_FR		Reserved	CFG_LOCK_1
rwl		rwl		rwl		r	rwl

Field	Bits	Type	Description
2MHZ_FREQ	7:5	rwl	Charge Pump Switching Frequency Setting 000 _B , 1.8MHz 001 _B , 2.0MHz (default value) 010 _B , 2.2MHz 011 _B , 2.4MHz 100 _B , Reserved 101 _B , Reserved 110 _B , Reserved 111 _B , Reserved
I_PEAK_TH	4	rwl	VCC1 Active Peak Threshold Selection 0 _B , low VCC1 active peak threshold selected (ICC1,peak_1) 1 _B , high VCC1 active peak threshold selected (ICC1,peak_2).
SS_MOD_FR	3:2	rwl	Spread Spectrum Modulation Frequency Setting of integrated 2MHz oscillator for charge pump 00 _B , Spread Spectrum disabled 01 _B , 15.625kHz Modulation Frequency 10 _B , 31.250kHz Modulation Frequency 11 _B , 62.500kHz Modulation Frequency
Reserved	1	r	Reserved, always reads as 0
CFG_LOCK_1	0	rwl	Configuration Lock Bit - Level 1 0 _B , Bits with bit type 'rwl' (except CP_EN and GPIO) can be modified 1 _B , Bits with bit type 'rwl' (except CP_EN and GPIO) are locked and cannot be modified anymore until next device power-up.

Notes

1. The configuration locking becomes effective after CSN changes from Low to High once the CFG_LOCK_1 bit was set. The locking is active until the next device power-up ($V_S < V_{POR,P}$), i.e. also CFG_LOCK_1 is locked in this case. The CFG_LOCK_1 will stay unchanged by a soft reset.
2. After t_{RD1} has expired, the default value is resumed after power-up or the configured value after SBC Sleep- or Fail-Safe Mode. In case the **CFG_LOCK_1** bit is set, then the soft reset value is like the Restart value.

Serial Peripheral Interface

GPIO_CTRL

GPIO Configuration Control (Address 001 0111_B)

POR Value: 0000 0000_B; Restart Value/Soft Reset Value: 0000 0yyy_B

7	6	5	4	3	2	1	0
Reserved					GPIO		
r					rwhl		

Field	Bits	Type	Description
Reserved	7:3	r	Reserved, always reads as 0
GPIO	2:0	rwhl	GPIO Configuration 000 _B , FO selected (default) 001 _B , FO selected 010 _B , FO selected 011 _B , High-Side controlled by TIMER (Cyclic Sense) 100 _B , Off 101 _B , Wake input enabled (16us static filter) 110 _B , Low-Side Switch controlled by PWM 111 _B , High-Side Switch controlled by PWM

Notes

1. The Restart and Soft Reset Value depends on the respective GPIO configuration. Therefore the bit type is also 'rwhl' and the restart value is 'y'. See also [Table 22](#) in [Chapter 11.1.2](#) for more information on the GPIO behavior for the different SBC modes and Restart behavior.
2. In case the [CFG_LOCK_0](#) bit is set, then the soft reset value is like the Restart value.
3. If GPIO is configured as a wake input, then it is a default wake source in SBC Fail-Safe Mode .

PWM_CTRL

PWM Configuration Control (Address 001 1000_B)

POR / Soft Reset Value: 0000 0000_B; Restart Value: xxxx xxxx_B

7	6	5	4	3	2	1	0
PWM_DC							
rw							

Field	Bits	Type	Description
PWM_DC	7:0	rw	PWM Duty Cycle Setting (bit0 = LSB; bit7 = MSB) 0000 0000 _B , 100% Off, i.e. HS/LS = Off xxxx xxxx _B , On with duty cycle fraction of 255 1111 1111 _B , 100% On, i.e. HS/LS always On

Notes

1. 0% and 100% duty cycle settings are used to have the switch turned On or Off respectively.
2. A new duty cycle configuration will become effective after the previous period is completed.
3. The desired duty cycle should be set first before GPIO is enabled as PWM HS or PWM LS.

Serial Peripheral Interface

PWM_FREQ_CTRL

PWM Frequency Configuration Control (Address 001 1100_B)

POR / Soft Reset Value: 0000 0000_B; Restart Value: 0000 00xx_B

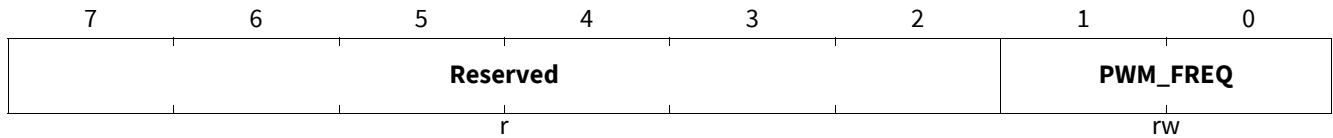

Field	Bits	Type	Description
Reserved	7:2	r	Reserved, always reads as 0
PWM_FREQ	1:0	rw	Spread Spectrum Modulation Frequency Setting 00 _B , 100Hz configuration 01 _B , 200Hz configuration 10 _B , 325Hz configuration 11 _B , 400Hz configuration

Note: A frequency change will become effective after the previous period is completed

HW_CTRL_3

Hardware Control 3 (Address 001 1101_B)

POR Value: 0000 0001_B; Restart Value/Soft Reset Value: 0000 0xxx_B

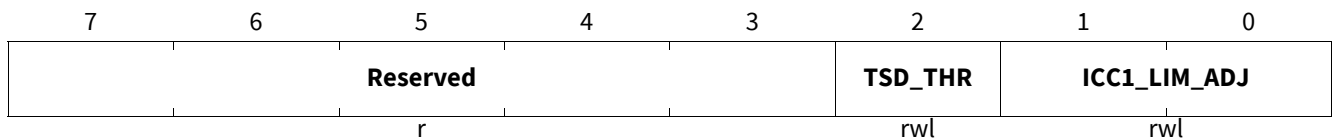

Field	Bits	Type	Description
Reserved	7:3	r	Reserved, always reads as 0
TSD_THR	2	rwl	Thermal Shutdown Threshold (TSD1 & TSD2) Configuration 0 _B , Default shutdown threshold selected 1 _B , higher shutdown threshold selected
ICC1_LIM_A DJ	1:0	rwl	Configuration of ICC1 current limitation 00 _B , 1 step down from default value (-25% of typ. default) 01 _B , default value (typ. 1000mA) 10 _B , 1 step up form default value (+20% of default), setting not recommended 11 _B , 2 steps up from default value (+50% of default), setting not recommended

Notes

1. In case the **CFG_LOCK_1** bit is set, then the soft reset value is like the Restart value., i.e. the configuration stays unchanged.

Serial Peripheral Interface

SYS_STATUS_CTRL_0

System Status Control Low Byte (Address 001 1110_B)

POR Value: 0000 0000_B; Restart Value/Soft Reset Value: xxxx xxxx_B

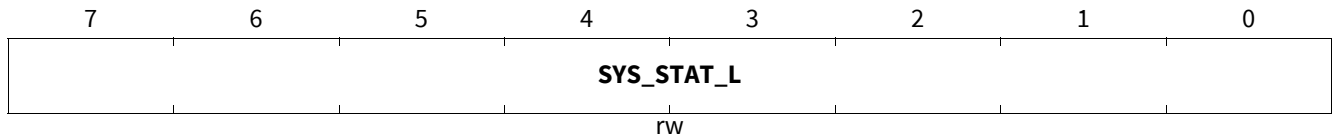

Field	Bits	Type	Description
SYS_STAT_L	7:0	rw	System Status Control Low Byte (bit0=LSB; bit7=MSB) Dedicated byte for system configuration, access only by microcontroller. Cleared after power up and Soft Reset

Notes

1. The **SYS_STATUS_CTRL_0** register is an exception for the default values, i.e. it will keep its configured value also after a Soft Reset.
2. This byte is intended for storing system configurations of the ECU by the microcontroller and is only writable in SBC Normal Mode and readable in SBC Stop Mode. The byte is not accessible by the SBC and contents are kept also after SBC Fail-Safe, Restart Mode or after Soft Reset. It allows the microcontroller to store system configuration without losing the data as long as the SBC supply voltage is above $V_{POR,f}$

SYS_STATUS_CTRL_1

System Status Control High Byte (Address 001 1111_B)

POR Value: 0000 0000_B; Restart Value/Soft Reset Value: xxxx xxxx_B

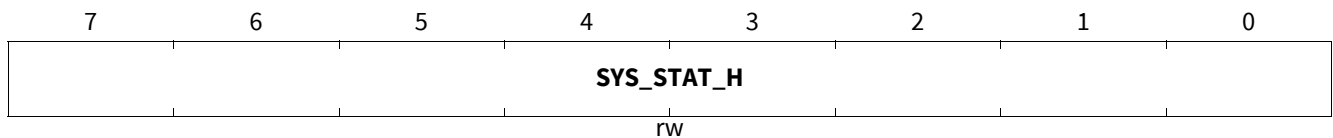

Field	Bits	Type	Description
SYS_STAT_H	7:0	rw	System Status Control High Byte (bit8=LSB; bit15=MSB) Dedicated byte for system configuration, access only by microcontroller. Cleared after power up and Soft Reset

Notes

1. The **SYS_STATUS_CTRL_1** register has the same functionality and behavior as **SYS_STATUS_CTRL_0**.

Serial Peripheral Interface

13.6 SPI Status Information Registers

READ/CLEAR Operation (see also [Chapter 13.3](#)):

- One 16-bit SPI command consist of two bytes:
 - the 7-bit address and one additional bit for the register access mode and
 - following the data byte
 The numbering of following bit definitions refers to the data byte and correspond to the bits D0...D7 and to the SPI bits 8...15 (see also figure).
- There are two different bit types:
 - ‘r’ = READ: read only bits (or reserved bits)
 - ‘rc’ = READ/CLEAR: readable and clearable bits
- Reading a register is done byte wise by setting the SPI bit 7 to “0” (= Read Only)
- Clearing a register is done byte wise by setting the SPI bit 7 to “1”
- SPI status registers are in general not cleared or changed automatically (an exception are the [WD_FAIL](#) bits). This must be done by the microcontroller via SPI command

The registers are addressed wordwise.

Table 28 Register Overview: SPI Status Information Registers

Register Short Name	Register Long Name	Offset Address	Reset Value
General Status Registers			
SUP_STAT_1	Supply Voltage Fail Status	100 0000 _B	Page 119
SUP_STAT_0	Supply Voltage Fail Status	100 0001 _B	Page 120
THERM_STAT	Thermal Protection Status	100 0010 _B	Page 121
DEV_STAT	Device Information Status	100 0011 _B	Page 121
BUS_STAT	Bus Communication Status	100 0100 _B	Page 122
WK_STAT_0	Wake-up Source and Information Status 0	100 0110 _B	Page 123
WK_STAT_1	Wake-up Source and Information Status 1	100 0111 _B	Page 123
WK_LVL_STAT	WK Input Level	100 1000 _B	Page 124
GPIO_OC_STAT	GPIO Overcurrent Status	101 0100 _B	Page 125
GPIO_OL_STAT	GPIO Open-Load Status	101 0101 _B	Page 125
Family and Product Information Register			
FAM_PROD_STAT	Family and Product Identification Register	111 1110 _B	Page 126

Serial Peripheral Interface

13.6.1 General Status Registers

SUP_STAT_1

Supply Voltage Fail Status (Address 100 0000_B)

POR / Soft Reset Value: 0000 0000_B; Restart Value: 0xx0 00xx_B

7	6	5	4	3	2	1	0
Reserved	VS_UV	VS_OV	Reserved			VCC1_OV	VCC1_WARN
r	rc	rc	r			rc	rc

Field	Bits	Type	Description
Reserved	7	r	Reserved, always reads as 0
VS_UV	6	rc	VS Undervoltage Detection ($V_{S,UV}$) 0 _B , No VS undervoltage detected 1 _B , VS undervoltage detected (detection is only active when VCC1 is enabled - see also note below)
VS_OV	5	rc	VS Overvoltage Detection ($V_{S,UV}$) 0 _B , No VS overvoltage detected 1 _B , VS overvoltage detected (detection is only active when VCC1 is enabled - see also note below)
Reserved	4:2	r	Reserved, always reads as 0
VCC1_OV	1	rc	VCC1 Overvoltage Detection ($V_{CC1,OV,r}$) 0 _B , No VCC1 overvoltage warning 1 _B , VCC1 overvoltage detected
VCC1_WARN	0	rc	VCC1 Undervoltage Prewarning ($V_{PW,f}$) 0 _B , No VCC1 undervoltage prewarning 1 _B , VCC1 undervoltage prewarning detected

Notes

1. The VCC1 undervoltage prewarning threshold $V_{PW,f}/V_{PW,r}$ is a fixed threshold and independent of the VCC1 undervoltage reset thresholds.
2. VS under voltage monitoring is not available in SBC Stop Mode due to current consumption saving requirements. Exception: VS under voltage detection is also available in SBC Stop Mode if the VCC1 load current is above the active peak threshold (I_{PEAK_TH}) or if VCC1 is below the VCC1 prewarning threshold (**VCC1_WARN** is set)
3. VS over voltage monitoring is not available in SBC Stop Mode due to current consumption saving requirements. Exception: VS over voltage detection is always available when the charge pump is enabled (**CP_EN** = '1') and also in SBC Stop Mode if the VCC1 load current is above the active peak threshold (I_{PEAK_TH}) or if VCC1 is below the VCC1 prewarning threshold (**VCC1_WARN** is set)

Serial Peripheral Interface

SUP_STAT_0

Supply Voltage Fail Status (Address 100 0001_B)

POR / Soft Reset Value: y000 0000_B; Restart Value: x00x xx0x_B

7	6	5	4	3	2	1	0
POR	Reserved		VCC2_OT	VCC2_UV	VCC1_SC	Reserved	VCC1_UV
rc	r		rc	rc	rc	r	rc

Field	Bits	Type	Description
POR	7	rc	Power-On Reset Detection 0 _B , No POR 1 _B , POR occurred
Reserved	6:5	r	Reserved, always reads as 0
VCC2_OT	4	rc	VCC2 Over Temperature Detection 0 _B , No over temperature 1 _B , VCC2 over temperature detected
VCC2_UV	3	rc	VCC2 Under Voltage Detection (V_{CC2,UV,f}) 0 _B , No VCC2 Under voltage 1 _B , VCC2 under voltage detected
VCC1_SC	2	rc	VCC1 Short to GND Detection (<V_{rtx} for t>2ms after switch On) 0 _B , No short 1 _B , VCC1 short to GND detected
Reserved	1	r	Reserved, always reads as 0
VCC1_UV	0	rc	VCC1 UV-Detection (due to V_{rtx} reset) 0 _B , No VCC1_UV detection 1 _B , VCC1 UV-Fail detected

Notes

1. The MSB of the POR/Soft Reset value is marked as 'y': the default value of the POR bit is set after Power-on reset (POR value = 1000 0000). However it is cleared after a SBC Soft Reset command (Soft Reset value = 0000 0000).
2. During Sleep Mode, the bits VCC1_SC, VCC1_OV and VCC1_UV will not be set when VCC1 is Off
3. The VCC1_UV bit is never updated in SBC Restart Mode, in SBC Init Mode it is only updated after RSTN was released, it is always updated in SBC Normal and Stop Mode, and it is always updated in any SBC modes in a VCC1_SC condition (after VCC1_UV = 1 for >2ms).

Serial Peripheral Interface

THERM_STAT

Thermal Protection Status (Address 100 0010_B)

POR / Soft Reset Value: 0000 0000_B; Restart Value: 0000 xxxx_B

7	6	5	4	3	2	1	0
Reserved			TSD2_SAFE	TSD2	TSD1	TPW	
r			rc	rc	rc	rc	

Field	Bits	Type	Description
Reserved	7:4	r	Reserved, always reads as 0
TSD2_SAFE	3	rc	TSD2 Thermal Shut-Down Safe State Detection 0 _B , No TSD2 safe state detected 1 _B , TSD2 safe state detected: >16 consecutive TSD2 events occurred, next TSD2 waiting time is 60s
TSD2	2	rc	TSD2 Thermal Shut-Down Detection 0 _B , No TSD2 event 1 _B , TSD2 OT detected - leading to SBC Fail-Safe Mode
TSD1	1	rc	TSD1 Thermal Shut-Down Detection 0 _B , No TSD1 fail 1 _B , TSD1 OT detected (affected module is disabled)
TPW	0	rc	Thermal Pre Warning 0 _B , No Thermal Pre warning 1 _B , Thermal Pre warning detected

Note: Temperature warning and shutdown bits are not reset automatically, even if the temperature pre warning or the TSD condition is not present anymore.

DEV_STAT

Device Information Status (Address 100 0011_B)

POR / Soft Reset Value: 0000 0000_B; Restart Value: xx00 xxxx_B

7	6	5	4	3	2	1	0
DEV_STAT		Reserved		WD_FAIL		SPI_FAIL	FAILURE
rc		r		rh		rc	rc

Field	Bits	Type	Description
DEV_STAT	7:6	rc	Device Status before Restart Mode 00 _B , Cleared (Register must be actively cleared) 01 _B , Restart due to failure (WD fail, TSD2, VCC1_UV, trial to access SLEEP MODE without any wake source activated); also after a wake-up from Fail-Safe Mode 10 _B , Sleep Mode 11 _B , Reserved
Reserved	5:4	r	Reserved, always reads as 0

Serial Peripheral Interface

Field	Bits	Type	Description
WD_FAIL	3:2	rh	Number of WD-Failure Events (1/2 WD failures depending on CFG1) 00 _B , No WD Fail 01 _B , 1x WD Fail, FO activation - Config 2 selected 10 _B , 2x WD Fail, FO activation - Config 1 / 3 / 4 selected 11 _B , Reserved (never reached)
SPI_FAIL	1	rc	SPI Fail Information 0 _B , No SPI fail 1 _B , Invalid SPI command detected
FAILURE	0	rc	Activation of Fail Output FO 0 _B , No Failure 1 _B , Failure occurred

Notes

1. The bits **DEV_STAT** show the status of the device before exiting SBC Restart Mode. Either the device came from regular SBC Sleep Mode or a failure (SBC Restart or SBC Fail-Safe Mode) occurred. See also “Invalid SPI Commands” in **Chapter 13.2**. Coming from SBC Sleep Mode will also be shown if there was a trial to enter SBC Sleep Mode without having cleared all wake flags before.
2. The **WD_FAIL** bits are implemented as a counter and are the only status bits, which are cleared automatically by the SBC. See also **Chapter 11.1.1**.
3. The **SPI_FAIL** bit can only be cleared via SPI command
4. In case of Config 2/4 the **WD_Fail** counter is frozen in case of WD trigger failure until a successful WD trigger.

BUS_STAT

Bus Communication Status (Address 100 0100_B)

POR / Soft Reset Value: 0000 0000_B; Restart Value: 0000 0xxx_B

7	6	5	4	3	2	1	0
Reserved	Reserved		Reserved		CAN_FAIL		VCAN_UV
r	r		r		rc		rc

Field	Bits	Type	Description
Reserved	7	r	Reserved, always reads as 0
Reserved	6:5	r	Reserved, always reads as 0
Reserved	4:3	r	Reserved, always reads as 0
CAN_FAIL	2:1	rc	CAN Failure Status 00 _B , No error 01 _B , CAN TSD 10 _B , CAN_TXD_DOM: TXD dominant time out detected (P_9.3.39) 11 _B , CAN_BUS_DOM: BUS dominant time out detected (P_9.3.40)
VCAN_UV	0	rc	Under Voltage CAN Bus Supply 0 _B , Normal operation 1 _B , CAN Supply under voltage detected. Transmitter disabled

Notes

1. The **VCAN_UV** comparator is enabled if the mode bit **CAN_1 = '1'**, i.e. in CAN Normal or CAN Receive Only Mode.

Serial Peripheral Interface

WK_STAT_0

Wake-up Source and Information Status 0 (Address 100 0110_B)

POR / Soft Reset Value: 0000 0000_B; Restart Value: 00xx x00x_B

7	6	5	4	3	2	1	0
Reserved		CAN_WU	TIMER_WU	Reserved		WK_WU	
r		rc	rc	r		rc	

Field	Bits	Type	Description
Reserved	7:6	r	Reserved, always reads as 0
CAN_WU	5	rc	Wake-up via CAN Bus 0 _B , No Wake-up 1 _B , Wake-up
TIMER_WU	4	rc	Wake-up via TimerX 0 _B , No Wake-up 1 _B , Wake-up
Reserved	3:1	r	Reserved, always reads as 0
WK_WU	0	rc	Wake-up via WK 0 _B , No Wake-up 1 _B , Wake-up

Note: The respective wake source bit will also be set when the device is woken from SBC Fail-Safe Mode

WK_STAT_1

Wake-up Source and Information Status 1 (Address 100 0111_B)

POR / Soft Reset Value: 0000 0000_B; Restart Value: 0x00 0000_B

7	6	5	4	3	2	1	0
Reserved			GPIO_WK_WU	Reserved			
r			rc	r			

Field	Bits	Type	Description
Reserved	7:5	r	Reserved, always reads as 0
GPIO_WK_WU	4	rc	Wake-up via GPIO if configured as WK 0 _B , No Wake-up 1 _B , Wake-up
Reserved	3:0	r	Reserved, always reads as 0

Serial Peripheral Interface

WK_LVL_STAT

WK Input Level (Address 100 1000_B)

POR / Soft Reset Value: xx0x 000x_B; Restart Value: xx0x 000x_B

7	6	5	4	3	2	1	0
SBC_DEV_LVL	CFG0_STATE	Reserved	GPIO_LVL	Reserved		WK_LVL	
r	r	r	r	r		r	

Field	Bits	Type	Description
SBC_DEV_LVL	7	r	Status of SBC Operating Mode at TEST Pin 0 _B , User Mode activated 1 _B , SBC Development Mode activated
CFG0_STATE	6	r	Device Configuration Status on pin INTN 0 _B , No external pull-up resistor connected on INTN (Config 2/4) 1 _B , External pull-up resistor connected on INTN (Config 1/3)
Reserved	5	r	Reserved, always reads as 0
GPIO_LVL	4	r	Status of GPIO if configured as GPIO (WK, LS or HS function) 0 _B , Low Level (=0) 1 _B , High Level (=1)
Reserved	3:1	r	Reserved, always reads as 0
WK_LVL	0	r	Status of WK 0 _B , Low Level (=0) 1 _B , High Level (=1)

Note: WK_LVL_STAT is updated in SBC Normal and Stop Mode and also in SBC Init and Restart Mode. See below for exceptions. In Cyclic Sense or wake mode, the registers contain the sampled level, i.e. the registers are updated after every sampling.

Note: GPIO_LVL is updated in SBC Normal and Stop Mode and also in SBC Init and Restart Mode if configured as wake input, low-side switch or high-side switch without Cyclic Sense (in case of FO configuration the status is flagged with the **FAILURE** bit). In case the respective feature is disabled then the WK_LVL_STAT bit will not be updated.

Note: In case the HV measurement function is enabled (**WK_MEAS=1**), then the bits WK_LVL and GPIO_LVL are not updated and reset.

Serial Peripheral Interface

GPIO_OC_STAT

GPIO Overcurrent Status (Address 101 0100_B)

POR / Soft Reset Value: 0000 0000_B; Restart Value: 0x00 0000_B

7	6	5	4	3	2	1	0	
Reserved	GPIO_OC	Reserved						
r	rc	r						

Field	Bits	Type	Description
Reserved	7	r	Reserved, always reads as 0
GPIO_OC	6	rc	Overcurrent Detection on GPIO (if configured as LS or HS) 0 _B , No OC 1 _B , OC detected
Reserved	5:0	r	Reserved, always reads as 0

Note: The same status bit is used for the low-side and high-side configuration. The bit always applies for the actual configuration. In case the switch is disabled or another configuration is used then a flagged bit will stay set until it is cleared by the microcontroller;

GPIO_OL_STAT

GPIO Open-Load Status (Address 101 0101_B)

POR / Soft Reset Value: 0000 0000_B; Restart Value: 0x00 0000_B

7	6	5	4	3	2	1	0	
Reserved	GPIO_OL	Reserved						
r	rc	r						

Field	Bits	Type	Description
Reserved	7	r	Reserved, always reads as 0
GPIO_OL	6	rc	Open-Load Detection on GPIO (if configured as HS) 0 _B , No OL 1 _B , OL detected
Reserved	5:0	r	Reserved, always reads as 0

Serial Peripheral Interface

13.6.2 Family and Product Information Register

FAM_PROD_STAT

Family and Product Identification Register (Address 111 1110_B)

POR / Soft Reset Value: 0101 yyyy_B; Restart Value: 0101 yyyy_B

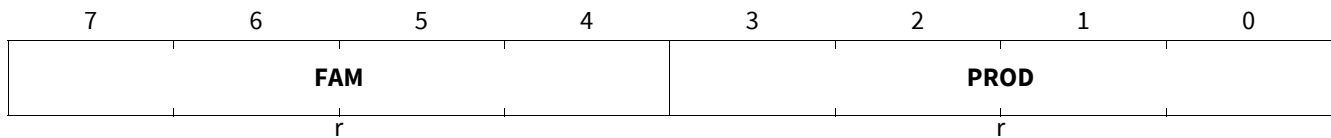

Field	Bits	Type	Description
FAM	7:4	r	SBC Family Identifier (bit4=LSB; bit7=MSB) 0 0 01 _B , Driver SBC Family 0 0 10 _B , DC/DC-SBC Family 0 0 11 _B , Mid-Range SBC Family 0 100 _B , Multi-CAN SBC Family 0 101 _B , LITE SBC Family 0 111 _B , Mid-Range+ SBC Family x x x x _B , reserved for future products
PROD	3:0	r	SBC Product Identifier (bit0=LSB; bit3=MSB) 0 1 10 _B , TLE9461ES (VCC1 = 5V, no SWK) / TLE9461-3ES (VCC1 = 5V, SWK) 0 1 1 1 _B , TLE9461ESV33 (VCC1 = 3.3V, no SWK) / TLE9461-3ESV33 (VCC1 = 3.3V, SWK) 1 1 1 0 _B , TLE9471ES (VCC1 = 5V, no SWK) / TLE9471-3ES(VCC1 = 5V, SWK) 1 1 1 1 _B , TLE9471ESV33 (VCC1 = 3.3V, no SWK) / TLE9471-3ESV33 (VCC1 = 3.3V, SWK)

Notes

1. The actual default register value after POR, Soft Reset or Restart of PROD depends on the respective device. Therefore the value 'y' is specified.
2. SWK = Selective Wake feature in CAN Partial Networking standard

Serial Peripheral Interface

13.7 Electrical Characteristics

Table 29 Electrical Characteristics

$V_S = 5.5\text{ V to }28\text{ V}$, $T_j = -40^\circ\text{C to }+150^\circ\text{C}$, all voltages with respect to ground, positive current flowing into pin (unless otherwise specified)

Parameter	Symbol	Values			Unit	Note or Test Condition	Number
		Min.	Typ.	Max.			
SPI frequency							
Maximum SPI frequency	$f_{\text{SPI,max}}$	–	–	4.0	MHz	¹⁾	P_16.7.1
SPI Interface; Logic Inputs SDI, CLK and CSN							
H-input Voltage Threshold	V_{IH}	–	–	$0.7 \times V_{\text{CC1}}$	V	–	P_16.7.2
L-input Voltage Threshold	V_{IL}	$0.3 \times V_{\text{CC1}}$	–	–	V	–	P_16.7.3
Hysteresis of input Voltage	V_{IHY}	$0.08 \times V_{\text{CC1}}$	$0.12 \times V_{\text{CC1}}$	$0.4 \times V_{\text{CC1}}$	V	¹⁾	P_16.7.4
Pull-up Resistance at pin CSN	R_{ICSN}	25	40	55	k Ω	$V_{\text{CSN}} = 0.7 \times V_{\text{CC1}}$	P_16.7.5
Pull-down Resistance at pin SDI and CLK	$R_{\text{ICLK/SDI}}$	25	40	55	k Ω	$V_{\text{SDI/CLK}} = 0.2 \times V_{\text{CC1}}$	P_16.7.6
Input Capacitance at pin CSN, SDI or CLK	C_{I}	–	10	–	pF	¹⁾	P_16.7.7
Logic Output SDO							
H-output Voltage Level	V_{SDOH}	$0.8 \times V_{\text{CC1}}$	–	–	V	$I_{\text{DOH}} = -1.6\text{ mA}$	P_16.7.8
L-output Voltage Level	V_{SDOL}	–	–	$0.2 \times V_{\text{CC1}}$	V	$I_{\text{DOL}} = 1.6\text{ mA}$	P_16.7.9
Tristate Leakage Current	I_{SDOLK}	-10	–	10	μA	$V_{\text{CSN}} = V_{\text{CC1}}$; $0\text{ V} < V_{\text{DO}} < V_{\text{CC1}}$	P_16.7.10
Tristate Input Capacitance	C_{SDO}	–	10	15	pF	¹⁾	P_16.7.11
Data Input Timing¹⁾							
Clock Period	t_{pCLK}	250	–	–	ns	–	P_16.7.12
Clock High Time	t_{CLKH}	125	–	–	ns	–	P_16.7.13
Clock Low Time	t_{CLKL}	125	–	–	ns	–	P_16.7.14
Clock Low before CSN Low	t_{bef}	125	–	–	ns	–	P_16.7.15
CSN Setup Time	t_{lead}	250	–	–	ns	–	P_16.7.16
CLK Setup Time	t_{lag}	250	–	–	ns	–	P_16.7.17
Clock Low after CSN High	t_{beh}	125	–	–	ns	–	P_16.7.18
SDI Set-up Time	t_{DISU}	100	–	–	ns	–	P_16.7.19
SDI Hold Time	t_{DIHO}	50	–	–	ns	–	P_16.7.20
Input Signal Rise Time at pin SDI, CLK and CSN	t_{rIN}	–	–	50	ns	–	P_16.7.21

Serial Peripheral Interface

Table 29 Electrical Characteristics (cont'd)

$V_S = 5.5\text{ V to }28\text{ V}$, $T_j = -40^\circ\text{C to }+150^\circ\text{C}$, all voltages with respect to ground, positive current flowing into pin (unless otherwise specified)

Parameter	Symbol	Values			Unit	Note or Test Condition	Number
		Min.	Typ.	Max.			
Input Signal Fall Time at pin SDI, CLK and CSN	t_{fIN}	-	-	50	ns	-	P_16.7.22
Delay Time for Mode Changes	$t_{Del,Mode}$	-	-	6	μs	²⁾ includes internal oscillator tolerance	P_16.7.23
CSN High Time	$t_{CSN(High)}$	3	-	-	μs	-	P_16.7.24

Data Output Timing¹⁾

SDO Rise Time	t_{rSDO}	-	30	80	ns	$C_L = 100\text{ pF}$	P_16.7.25
SDO Fall Time	t_{fSDO}	-	30	80	ns	$C_L = 100\text{ pF}$	P_16.7.26
SDO Enable Time	t_{ENSDO}	-	-	50	ns	low impedance	P_16.7.27
SDO Disable Time	t_{DISSDO}	-	-	50	ns	high impedance	P_16.7.28
SDO Valid Time	t_{VASDO}	-	-	50	ns	$C_L = 100\text{ pF}$	P_16.7.29

- 1) Not subject to production test; specified by design
- 2) Applies to all mode changes triggered via SPI commands

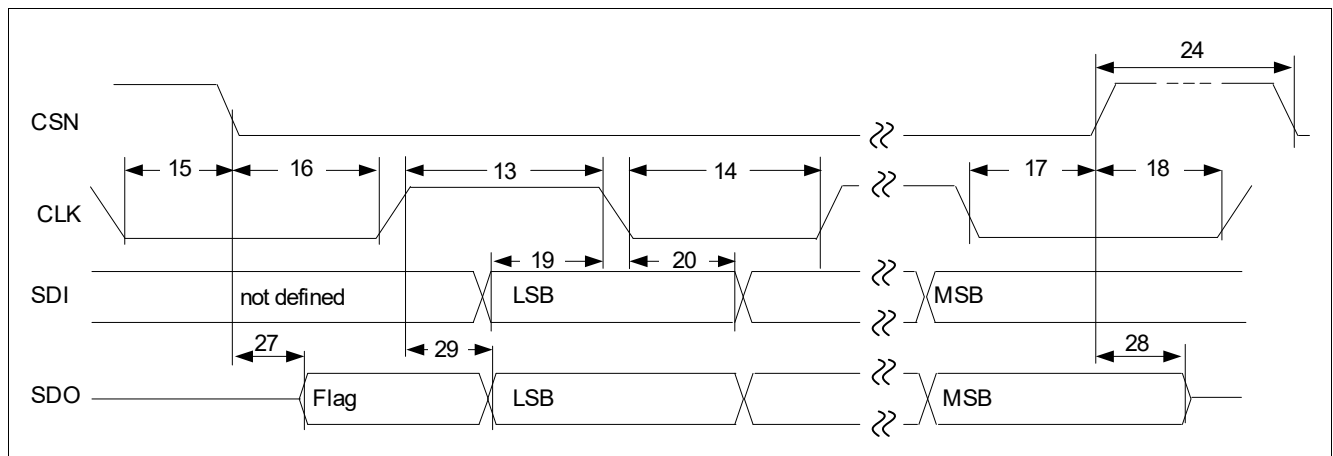

Figure 43 SPI Timing Diagram

Note: Numbers in drawing correlate to the last 2 digits of the Number field in the Electrical Characteristics table.

Application Information

14 Application Information

Note: The following information is given as a hint for the implementation of the device only and shall not be regarded as a description or warranty of a certain functionality, condition or quality of the device.

14.1 Application Diagrams

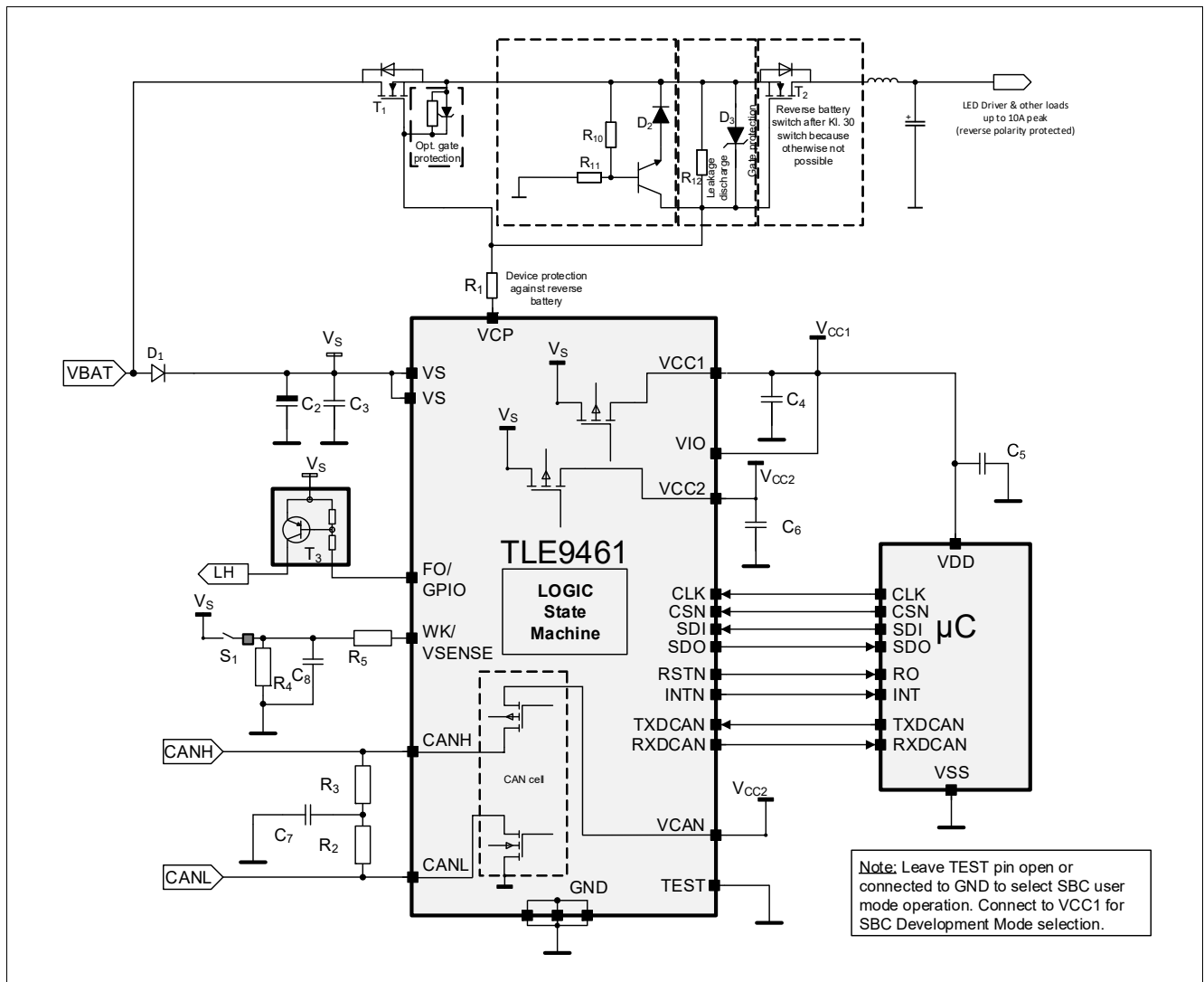

Figure 44 TLE9461ES Application Diagram

Notes

1. This is a very simplified example of an application circuit. The function must be always verified in the real application.
2. Reverse polarity protection circuitry (D2, R10, R11) is mandatory for dynamic reverse polarity requirements, i.e. if load is not to be turned On. To further reduce the quiescent current, a diode can be placed optionally in series with GND and R11.

Application Information

Figure 45 shows the required circuitry for an off-board LED control using the GPIO pin with the high-side switch configuration.

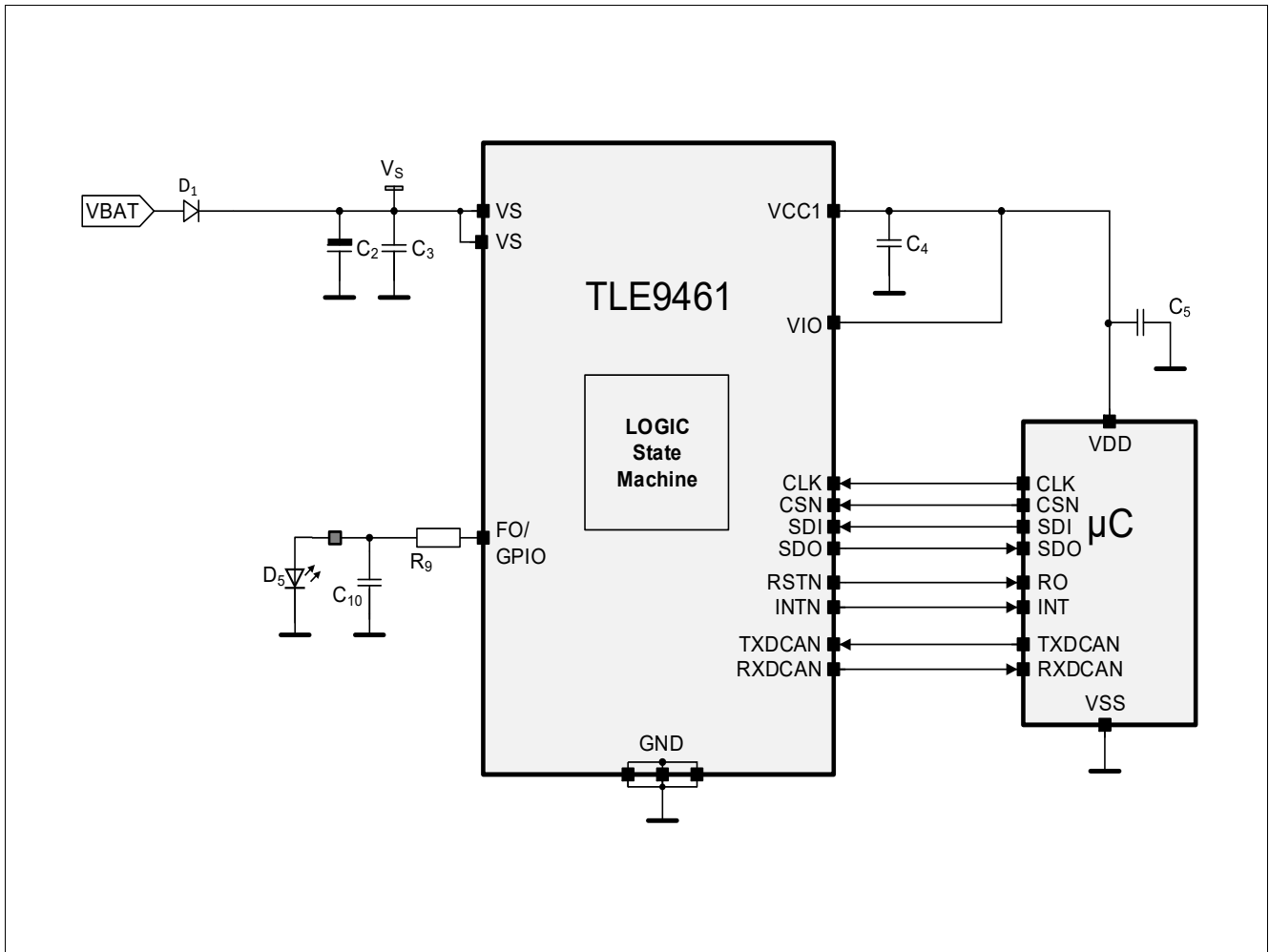

Figure 45 Simplified Application Diagram showing an off-board LED control with the GPIO pin

Note: This is a very simplified example of an application circuit. The off-board LED control function must be verified in the real application. The external circuitry is a minimum requirement and may vary depending on respective requirements. The same protection requirements apply for the configuration of FO/GPIO as low-side switch or wake input.

Application Information

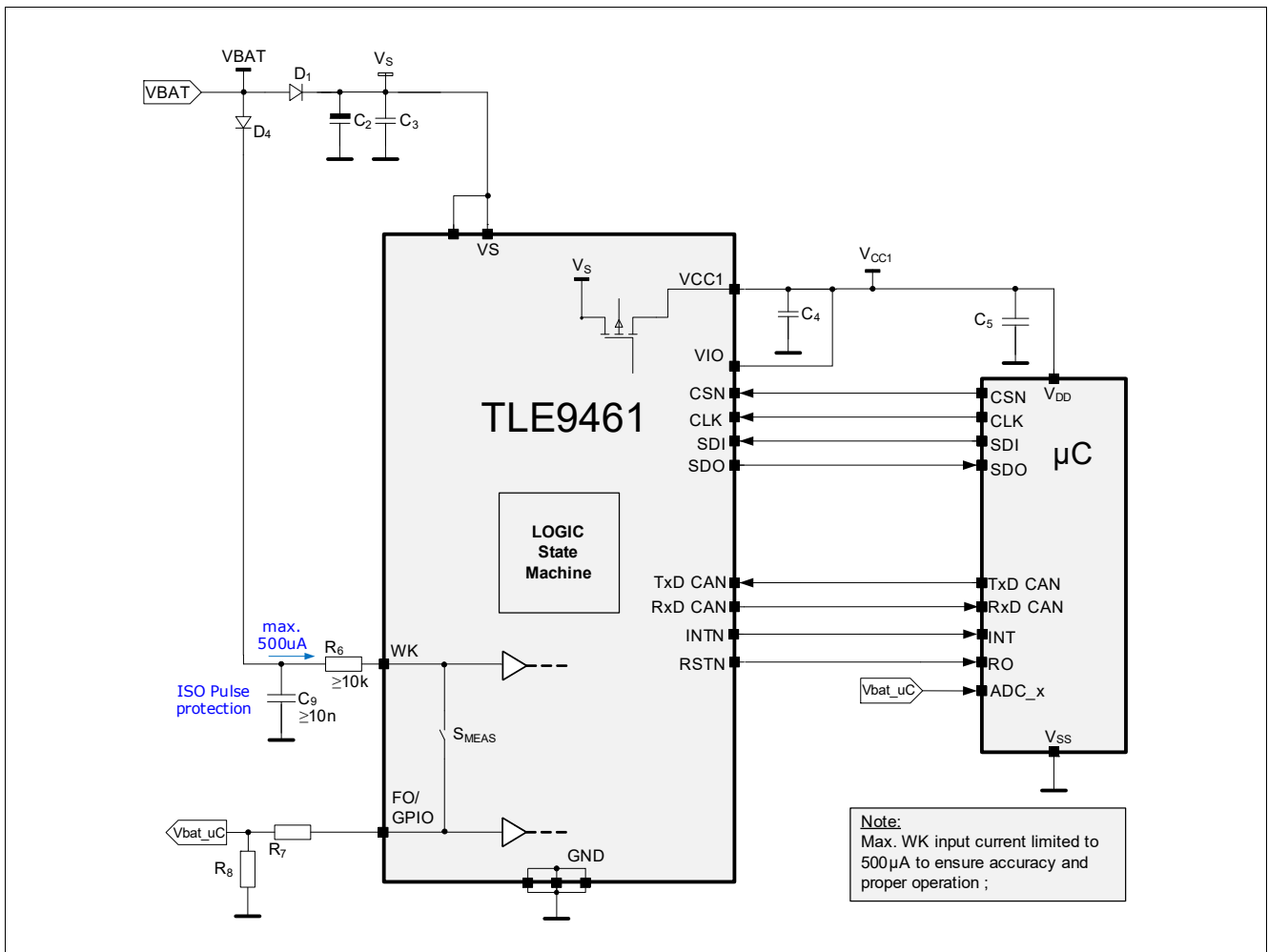

Figure 46 Simplified Application Diagram showing the Alternative High-Voltage Measurement Function via WK/SENSE and FO/GPIO

Note: This is a simplified example of an application circuit. The function must be verified in the real application. WK must be connected to signal to be measured and FO/GPIO is the output to the microcontroller supervision function. The maximum current into WK must be <math><500\mu\text{A}</math>. The minimum current into WK should be >math>>5\mu\text{A}</math> to ensure proper operation.

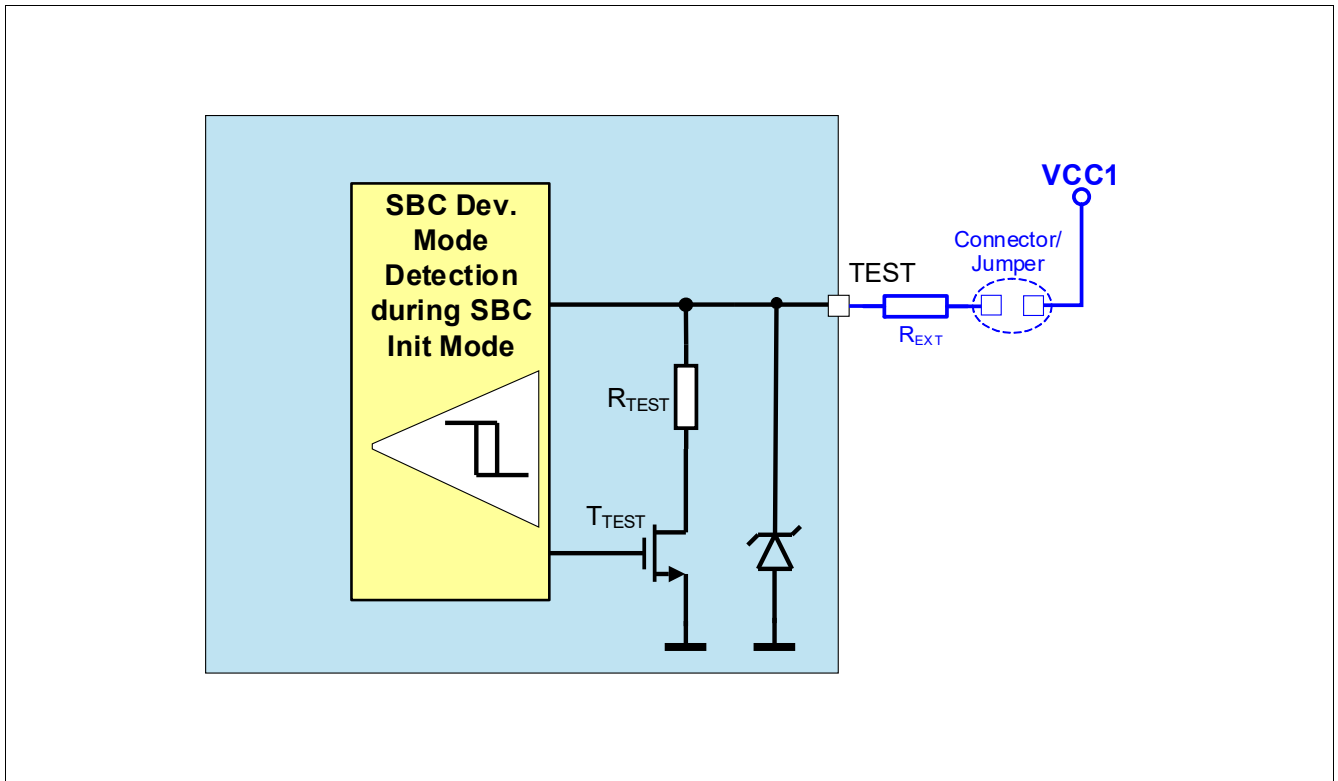

Figure 47 Increasing the Robustness of the pin TEST during Debugging or Programming

Application Information

Table 30 Bill of Material for Simplified Application Diagram

Ref.	Typical Value	Purpose / Comment
Capacitances		
C2	68 μ F	Buffering capacitor to cut off battery spikes, value depending on application requirements
C3	100nF ceramic	EMC, blocking capacitor, ceramic X7R or equivalent, ESR < 50m Ω
C4	2.2 μ F low ESR	Blocking capacitor, min. 1 μ F for stability and max. 47 μ F recommended
C5	100nF ceramic	Spike filtering, ceramic X7R or equivalent, ESR < 50 m Ω to improve stability of supply for microcontroller; not needed for SBC
C6	2.2 μ F low ESR	Blocking capacitor, min. 470nF for stability; if used for CAN supply place a 100nF ceramic capacitor in addition very close to VCAN pin for optimum EMC behavior
C7	4.7nF / OEM dependent	Split termination stability
C8,9	10nF	Spike filtering, as required by application, mandatory protection for off-board connections, (see also Simplified Application Diagram with the Alternative Measurement Function)
C10	22nF	As required by application and GPIO current capability (see also Chapter 11.1.2), mandatory protection for off-board connections
Resistances		
R1	1k Ω	Device protection against reverse battery
R2	60 Ω / OEM dependent	CAN bus termination
R3	60 Ω / OEM dependent	CAN bus termination
R4	10k Ω	Wetting current of the switch, as required by application
R5,6	10k Ω	WK pin current limitation, e.g. for ISO pulses (see also Simplified Application Diagram with the Alternative Measurement Function)
R7, 8	depending on application and microcontroller	Voltage Divider resistor to adjust measurement voltage to microcontroller ADC input range (see also Simplified Application Diagram with the Alternative Measurement Function)
R9	10 Ω	As required by application, ESD protection, mandatory protection for off-board connections only
R10, 11	47k Ω	Reverse battery protection
R12	100k Ω	Leakage discharge resistor
Active Components		
D1	e.g. BAS 3010A, Infineon	Reverse polarity protection for VS supply pins
D2	e.g. BAS 21, Infineon	Reverse battery protection
D3	12V Zener Diode	Gate protection
D4	e.g. BAS 21, Infineon	Reverse battery protection for measurement circuitry
D5	e.g. LED	circuit example: Illumination LED
T1	e.g. IPB80N04S4-04	Terminal 30 (Kl. 30) Switch, N-MOSFET
T2	e.g. IPB80N04S4-04	Reverse battery protection, N-MOSFET

Application Information

Table 30 Bill of Material for Simplified Application Diagram (cont'd)

Ref.	Typical Value	Purpose / Comment
T3	e.g. BCR191W	High active FO control
uC	e.g. TC2xxx	Microcontroller

Application Information

14.2 ESD Tests

Tests for ESD robustness according to IEC61000-4-2 “GUN test” (150 pF, 330 Ω) have been performed. The results and test condition are available in a test report. The values for the tests are listed below.

Table 31 ESD “GUN test”¹⁾²⁾

Performed Test	Result	Unit	Remarks
ESD at pins CANH, CANL, VS, WK, VCC2 versus GND	> 6	kV	positive pulse
ESD at pins CANH, CANL, VS, WK, VCC2 versus GND	< -6	kV	negative pulse

1) ESD susceptibility “ESD GUN” according to EMC 1.3 Test specification, Section 4.3 (IEC 61000-4-2). Tested by external test house (IBEE Zwickau, EMC Test report Nr. 02-05-18).

2) ESD Test “Gun Test” is specified with external components for pins VS, WK, and VCC2. See the application diagram in [Chapter 14.1](#) for more information

EMC and ESD susceptibility tests according to SAE J2962-2 (V. 2014-01-23) have been performed. Tested by external test house (Jakob Mooser GmbH, Test report Nr. 145 / 2018)

14.3 Thermal Behavior of Package

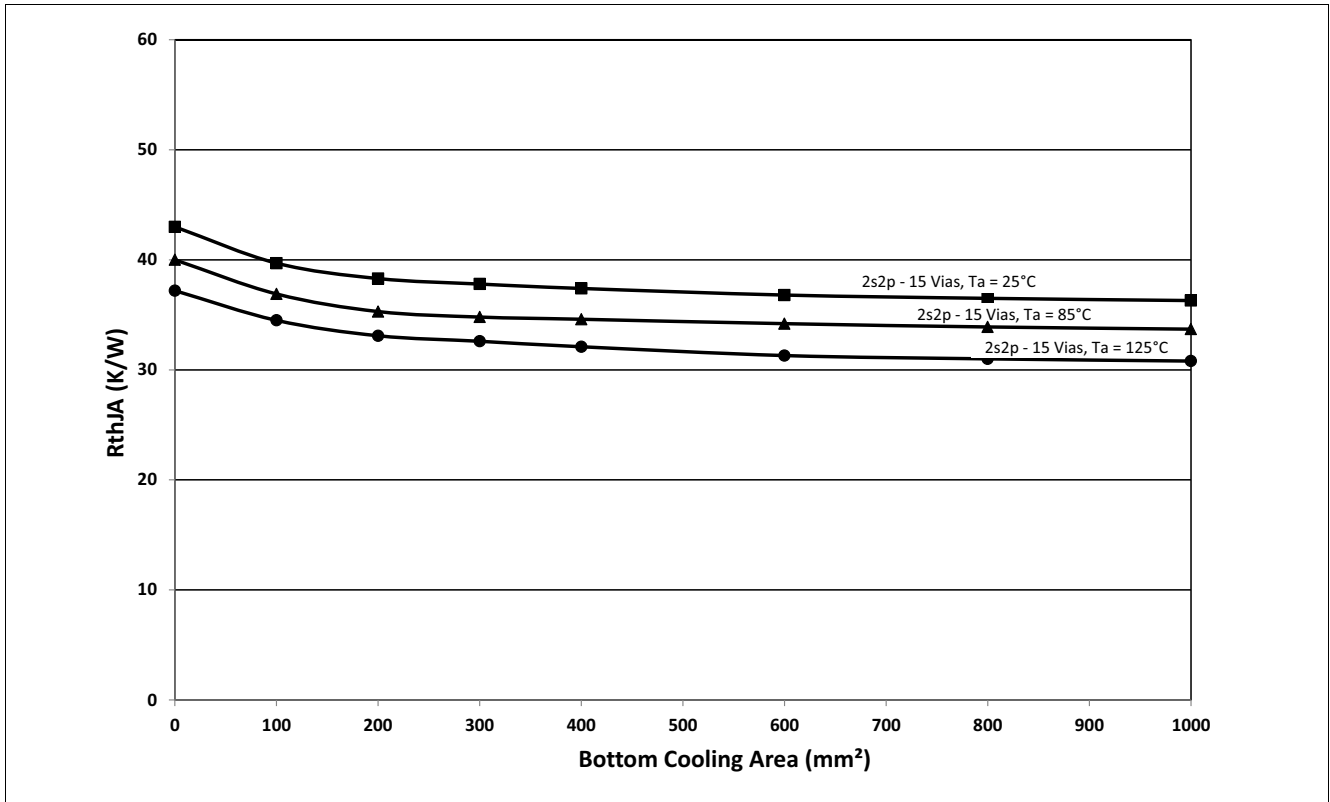

Figure 48 Thermal Resistance (R_{th_JA}) vs. Cooling Area

Application Information

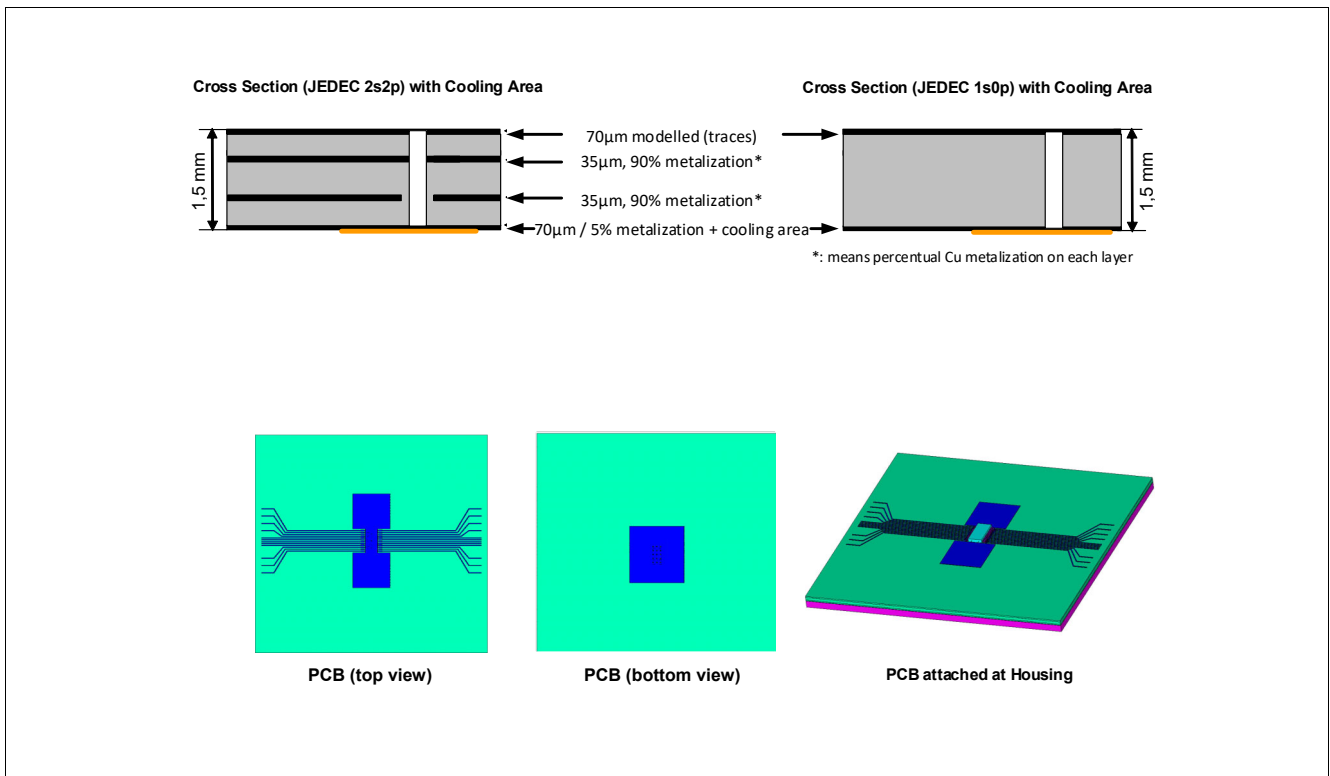

Figure 49 Board Setup

Board setup is defined according JESD 51-2, -5, -7.

Board: 75 x 75 x 1.5mm³ with 2 inner copper layers (35µm thick), with thermal via array under the exposed pad contacting the first inner copper layer and 300mm² cooling area on the bottom layer (70µm).

14.4 Further Application Information

- Please contact us for information regarding the pin FMEA
- For further information you may contact <http://www.infineon.com/>

Package Outlines

15 Package Outlines

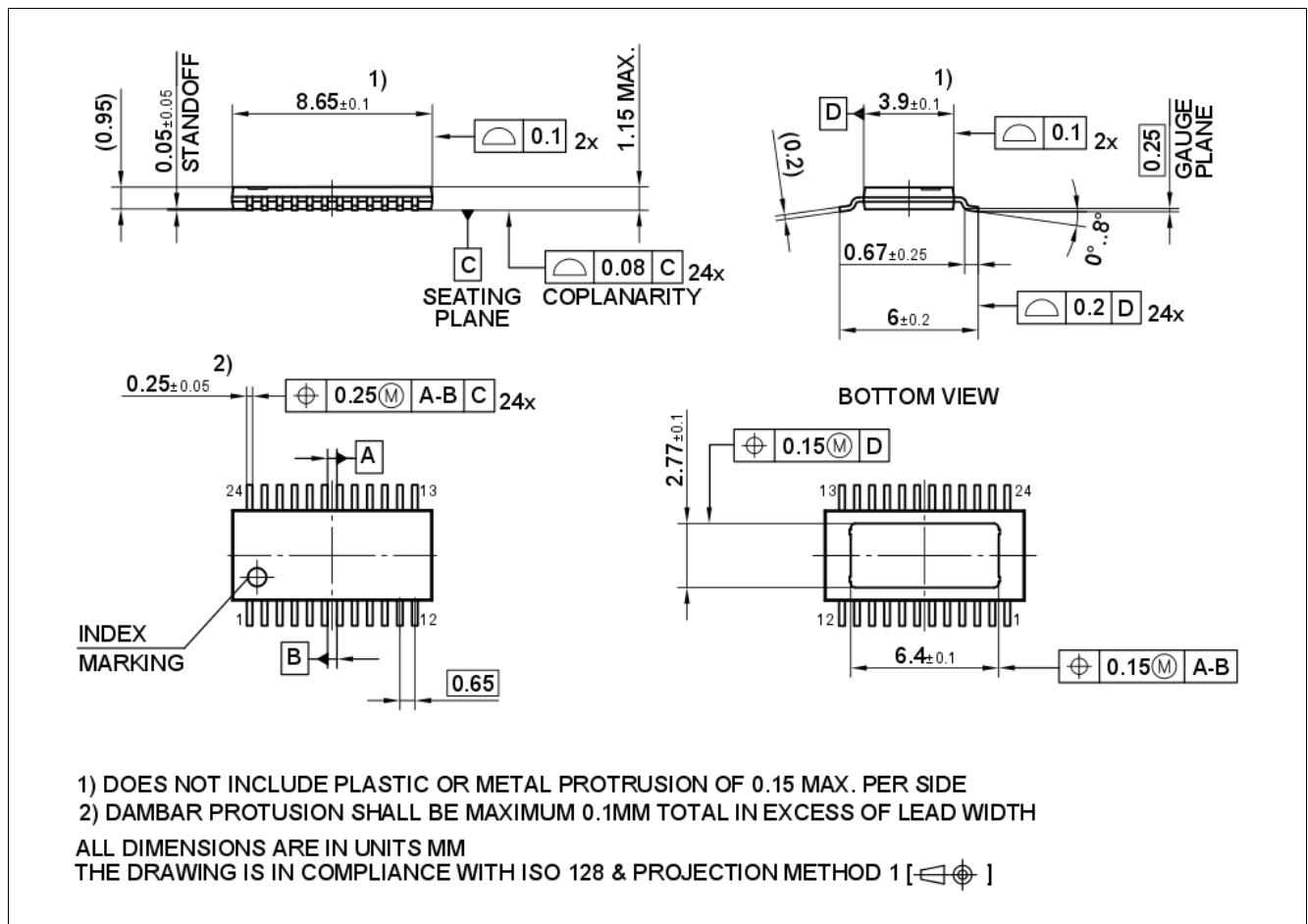

Figure 50 PG-TSDSO-24-1 Dimensions

Green Product (RoHS compliant)

To meet the world-wide customer requirements for environmentally friendly products and to be compliant with government regulations the device is available as a green product. Green products are RoHS-Compliant (i.e Pb-free finish on leads and suitable for Pb-free soldering according to IPC/JEDEC J-STD-020).

Revision History

16 Revision History

Revision	Date	Changes
1.0	2018-08-01	Initial Release
1.1	2019-09-27	Datasheet updated: <ul style="list-style-type: none">• Editorial changes• Updated Table 18<ul style="list-style-type: none">– added P_9.3.55 and P_9.3.56 (no product change)– tightened P_9.3.18– tightened P_9.3.8 and P_9.3.9 by additional footnote• Fixed wrong symbol for P_13.9.56• Added max. recommendation for C4 in Table 30

Trademarks

All referenced product or service names and trademarks are the property of their respective owners.

Edition 2019-09-27

Published by

Infineon Technologies AG

81726 Munich, Germany

© 2019 Infineon Technologies AG.

All Rights Reserved.

Do you have a question about any aspect of this document?

Email: erratum@infineon.com

Document reference

Z8F53477368

IMPORTANT NOTICE

The information given in this document shall in no event be regarded as a guarantee of conditions or characteristics ("Beschaffheitsgarantie").

With respect to any examples, hints or any typical values stated herein and/or any information regarding the application of the product, Infineon Technologies hereby disclaims any and all warranties and liabilities of any kind, including without limitation warranties of non-infringement of intellectual property rights of any third party.

In addition, any information given in this document is subject to customer's compliance with its obligations stated in this document and any applicable legal requirements, norms and standards concerning customer's products and any use of the product of Infineon Technologies in customer's applications.

The data contained in this document is exclusively intended for technically trained staff. It is the responsibility of customer's technical departments to evaluate the suitability of the product for the intended application and the completeness of the product information given in this document with respect to such application.

For further information on technology, delivery terms and conditions and prices, please contact the nearest Infineon Technologies Office (www.infineon.com).

WARNINGS

Due to technical requirements products may contain dangerous substances. For information on the types in question please contact your nearest Infineon Technologies office.

Except as otherwise explicitly approved by Infineon Technologies in a written document signed by authorized representatives of Infineon Technologies, Infineon Technologies' products may not be used in any applications where a failure of the product or any consequences of the use thereof can reasonably be expected to result in personal injury.