

TOSHIBA Photointerrupter Infrared LED + Photo IC

TLP1032(F), TLP1033A(F)

Lead(Pb)-Free

Domestic electrical appliances such as VTRs and CD players

Office equipment such as photocopiers, printers and fax machines

Vending machines

Position detectors

The TLP1032(F)/TLP1033A(F) is a high-withstanding-voltage photo-interrupter for digital output. The device combines a high-optical-output GaAs infrared LED with a high-sensitivity, high-gain Si photo-IC. The photo-IC, which supports a wide range of systems (3.3 V to 12 V), enables the device to consume less power than conventional devices. The device also features a narrow slit width and high resolution.

The short lead package allows automatic mounting.

- Designed for direct mounting on printed circuit boards (positioning pins included)
- The short lead package allows automatic mounting:
 - Lead length of 3.4 ± 0.3 mm
- Permissible board thickness: 1.6 mm or less
- Gap: 5 mm
- Resolution: Slit width of 0.5 mm
- Digital output (open-collector)
 - TLP1032(F) : Low-level output at shielding
 - TLP1033A(F): High-level output at shielding
- Direct connection to logic IC
- Power supply voltage: $V_{CC} = 2.7 \text{ V} \sim 15 \text{ V}$
- High-speed response
- Detector impermeable to visible light
- Package material: Polybutylene-terephthalate (UL94V-0, black)

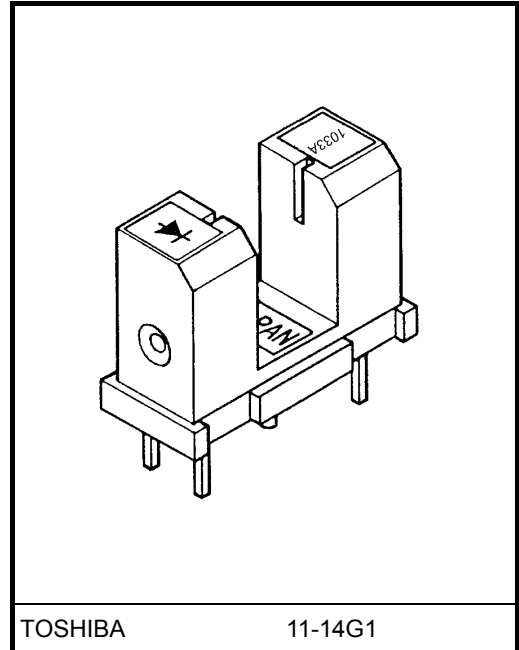

Weight: 0.6 g (typ.)

Absolute Maximum Ratings (Ta = 25°C)

| Characteristic | | Symbol | Rating | Unit | |
|--------------------------------------|---|-----------------------------|-------------|-------|-------|
| LED | Forward current | I_F | 50 | mA | |
| | Forward current derating | $\Delta I_F/^\circ\text{C}$ | (Ta > 25°C) | -0.33 | mA/°C |
| | | | (Ta > 85°C) | -2 | |
| Reverse voltage | | V_R | 5 | V | |
| Detector | Supply voltage | V_{CC} | 15 | V | |
| | Output voltage | V_O | 15 | V | |
| | Low-level output current (Ta = T _{opr}) | I_{OL} | 16 | mA | |
| Operating temperature | | T_{opr} | -30~95 | °C | |
| Storage temperature | | T_{stg} | -40~100 | °C | |
| Soldering temperature (5 s) (Note 1) | | T_{sol} | 260 | °C | |

Note: Using continuously under heavy loads (e.g. the application of high temperature/current/voltage and the significant change in temperature, etc.) may cause this product to decrease in the reliability significantly even if the operating conditions (i.e. operating temperature/current/voltage, etc.) are within the absolute maximum ratings and the operating ranges.

Please design the appropriate reliability upon reviewing the Toshiba Semiconductor Reliability Handbook ("Handling Precautions"/"Derating Concept and Methods") and individual reliability data (i.e. reliability test report and estimated failure rate, etc).

Note 1: Soldering is performed 1.5 mm from the bottom of the package.

Operating Ranges

| Characteristic | Symbol | Min | Typ. | Max | Unit |
|--------------------------|-----------|---------------|------|------|------|
| LED forward current | I_F | 8 (Note 2) | — | 20 | mA |
| Supply voltage | V_{CC} | 2.7 | 3.3 | 13.2 | V |
| Output voltage | V_O | — | — | 13.2 | V |
| Low-level output current | I_{OL} | — | — | 16 | mA |
| Operating temperature | T_{opr} | -25 | — | 95 | °C |

Note 2: The value 8 mA allows for a 50% optical fluctuation in the LED. The initial value of the threshold input current is 4 mA or less.

Electrical and Optical Characteristics

(unless otherwise specified: Ta = -30~95°C, VCC = 2.7~15 V)

| Characteristic | | Symbol | Test Conditions | Min | Typ. | Max | Unit | | |
|-----------------------------|--------------------------------|--|--|-------------|-------------|------|------|----|----|
| LED | Forward voltage | V _F | I _F = 10 mA, Ta = 25°C | 1.00 | 1.15 | 1.30 | V | | |
| | Reverse current | I _R | V _R = 5 V, Ta = 25°C | — | — | 10 | μA | | |
| | Peak emission wavelength | λ _P | I _F = 15 mA, Ta = 25°C | — | 940 | — | nm | | |
| Detector | Operating supply voltage | V _{CC} | — | 2.7 | — | 15 | V | | |
| | Low-level supply current | I _{CCL} | I _F = *1, Ta = 25°C | — | — | 1.6 | mA | | |
| | | | I _F = *1 | — | — | 2.0 | | | |
| | High-level supply current | I _{CCH} | I _F = *2, Ta = 25°C | — | — | 1.1 | mA | | |
| | | | I _F = *2 | — | — | 1.2 | | | |
| | Low-level output voltage | V _{OL} | I _{OL} = 16 mA, I _F = *1 Ta = 25°C | — | 0.05 | 0.3 | V | | |
| | | | I _{OL} = 16 mA, I _F = *1 | — | — | 0.4 | | | |
| High-level output current | I _{OH} | I _F = *2, V _O = 15 V | — | — | 6.3 | μA | | | |
| Peak sensitivity wavelength | λ _P | Ta = 25°C | — | 900 | — | nm | | | |
| Propagation characteristics | L → H threshold input current | I _{FLH} | Ta = 25°C | TLP1032(F) | — | — | 3 | mA | |
| | | | | | — | — | 4 | | |
| | H → L threshold input current | I _{FHL} | Ta = 25°C | TLP1033A(F) | — | — | 3 | mA | |
| | | | | | — | — | 4 | | |
| | Hysteresis | I _{FHL} /I _{FLH} | — | — | TLP1032(F) | — | 0.67 | — | — |
| | | | | | TLP1033A(F) | — | 1.5 | — | |
| | Propagation delay time (L → H) | t _{pLH} | V _{CC} = 3.3 V I _F = 15 mA R _L = 10 kΩ Ta = 25°C | — | TLP1032(F) | — | — | 9 | μs |
| | | | | | TLP1033A(F) | — | — | 15 | |
| | Propagation delay time (H → L) | t _{pHL} | | TLP1032(F) | — | — | 15 | | |
| | | | | TLP1033A(F) | — | — | 9 | | |
| | Rise time | t _r | | TLP1032(F) | — | 0.02 | 0.5 | | |
| | | | | TLP1033A(F) | — | 0.8 | 3 | | |
| Fall time | t _f | TLP1032(F) | | — | 0.8 | 3 | | | |
| | | TLP1033A(F) | | — | 0.02 | 0.5 | | | |

*1 0 mA for the TLP1032(F); 15 mA for the TLP1033A(F).

*2 15 mA for the TLP1032(F); 0 mA for the TLP1033A(F).

Note 3: The switching time measurement circuit and waveform are as follows:

TLP1032(F)

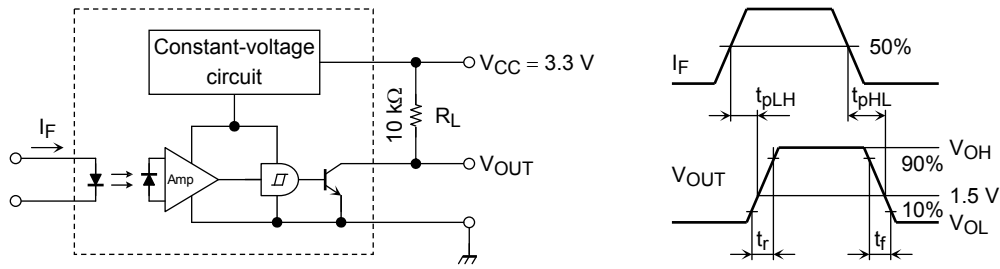

TLP1033A(F)

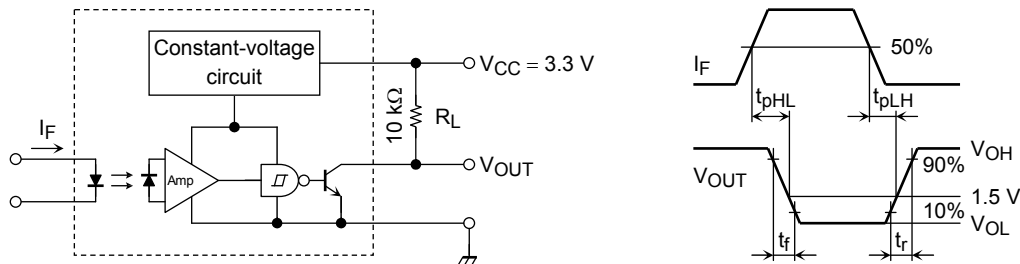

Markings

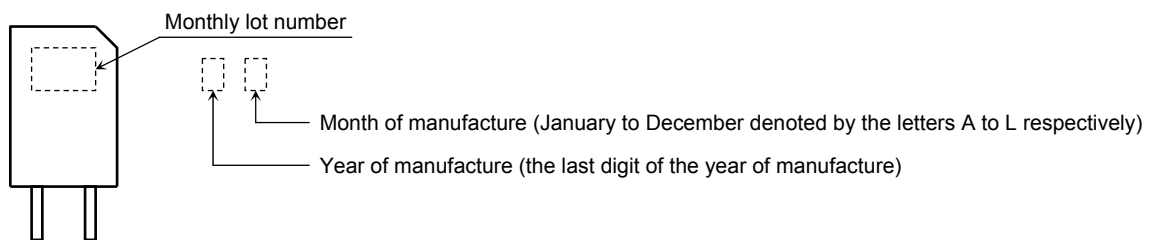

Precautions

- When removing flux with chemicals after soldering, clean only the soldered part of the leads. Do not immerse the entire package in the cleaning solvent. Chemical residue on the LED emitter or the photodetector inside the photo-IC case may adversely affect the optical characteristics of the device and may drastically reduce the threshold input current.
- The case is made of polybutylene-terephthalate. Oil or chemicals may cause the package to melt or crack. Care should be taken regarding the environment in which the device is to be installed.
- Mount the device on a level surface.
- Output fluctuates for 100 μs after power-on while the internal circuit stabilizes.
- To stabilize the power line, insert a bypass capacitor of up to 0.01 μF between V_{CC} and GND, close to the device.
- The threshold input current increases over time due to current flowing in the infrared LED. The design of circuits that are to incorporate the device must take into account the change in threshold input current over time. The change in threshold input current is equal to the reciprocal of the change in LED infrared optical output.

$$\frac{I_{FHL}(t)}{I_{FHL}(0)} = \left(\frac{P_O(t)}{P_O(0)} \right)^{-1}$$

- Choose a high-quality shutter material that is impermeable to light. If the material is of inferior quality, light from the LED may pass through the shutter, causing the device to malfunction.

Package Dimensions: TOSHIBA 11-14G1

Unit: mm

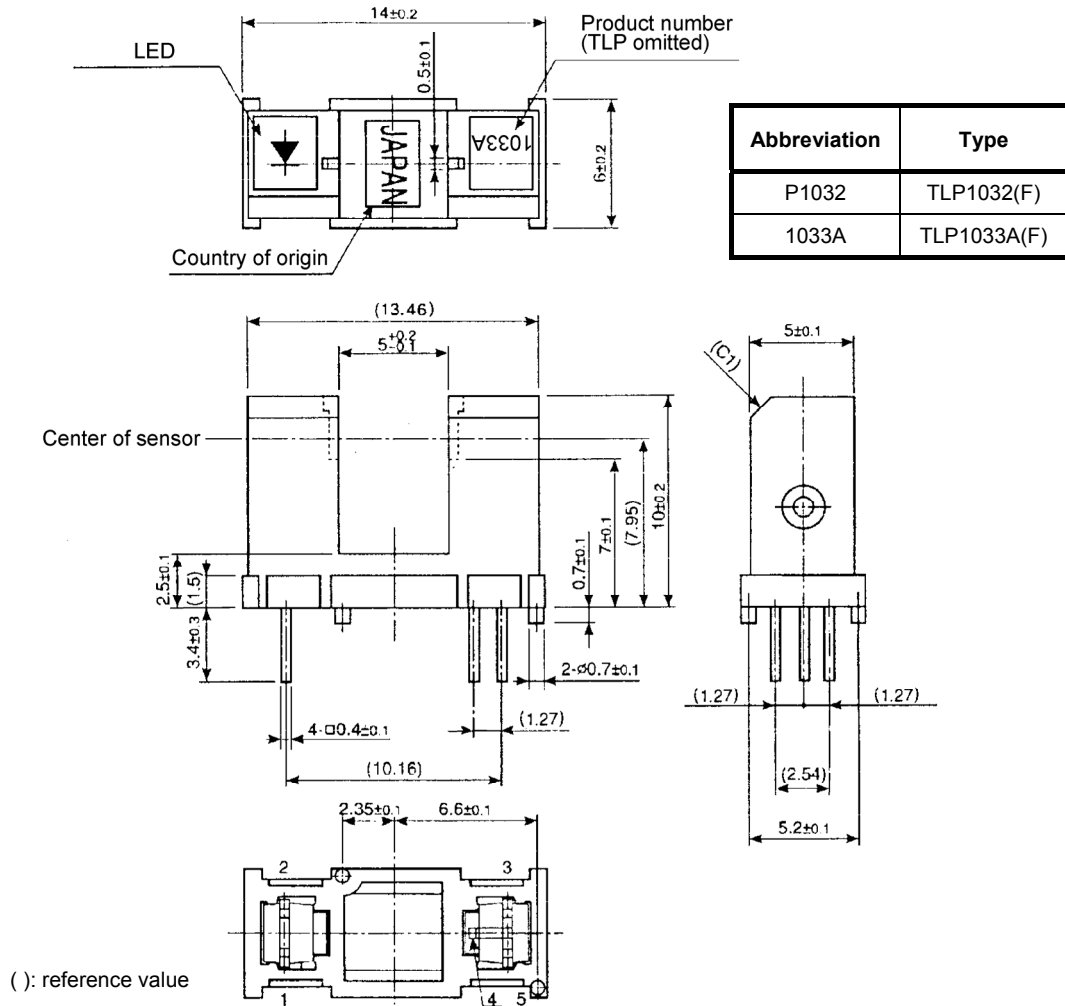

Weight: 0.6 g (typ.)

Pin Connections

TLP1032(F)

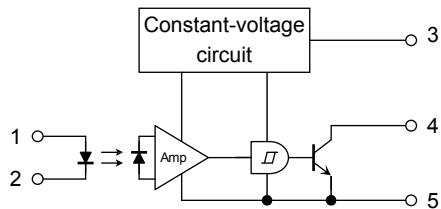

TLP1033A(F)

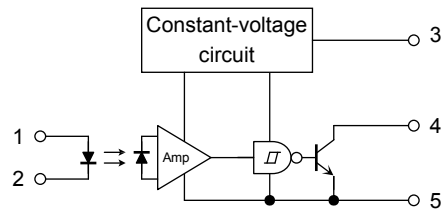

- 1: Anode
- 2: Cathode
- 3: VCC
- 4: OUT
- 5: GND

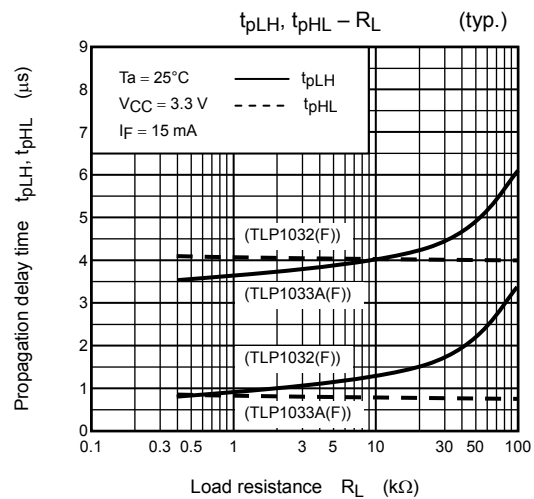
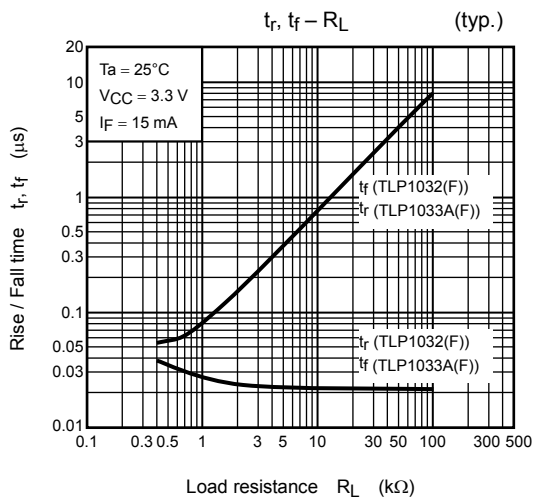
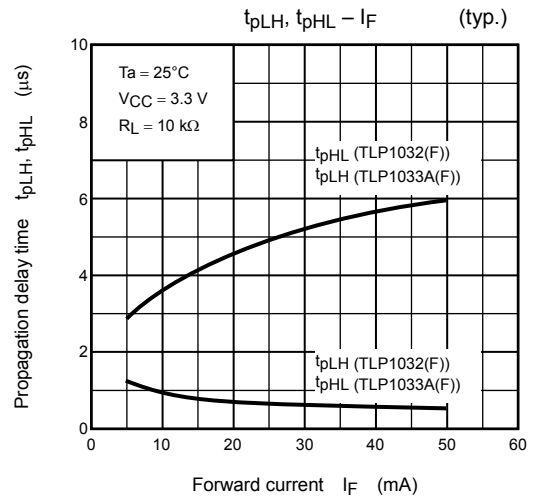
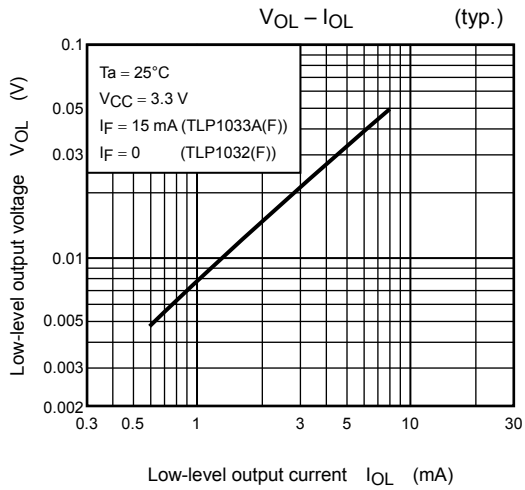
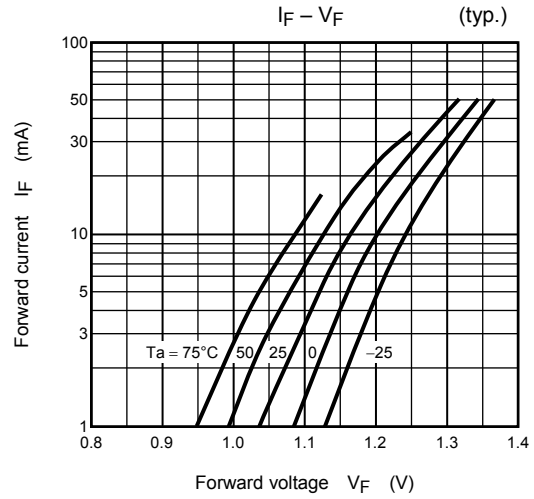
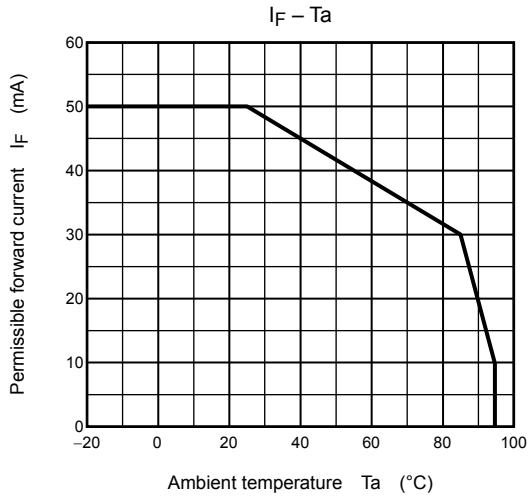

TLP1032(F) Detection position characteristic (1) (typ.)

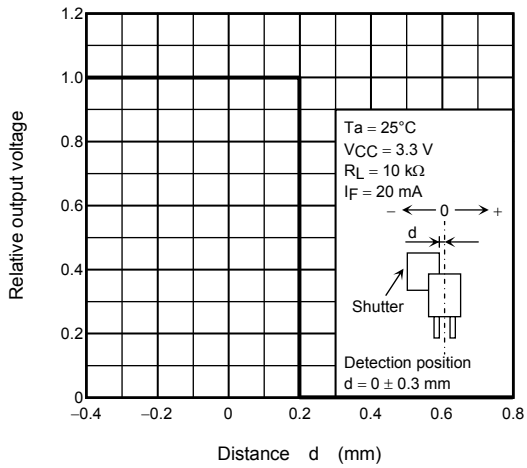

TLP1032(F) Detection position characteristic (2) (typ.)

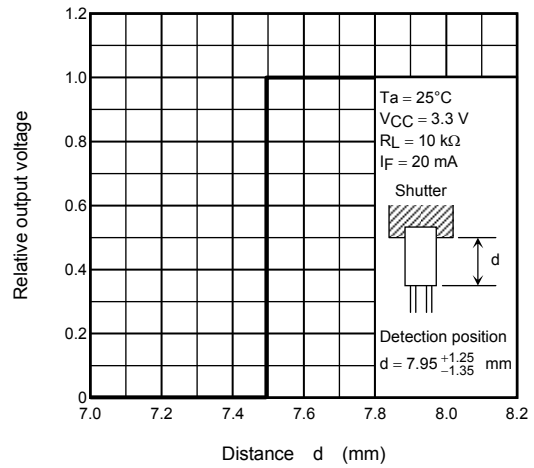

TLP1033A(F) Detection position characteristic (1) (typ.)

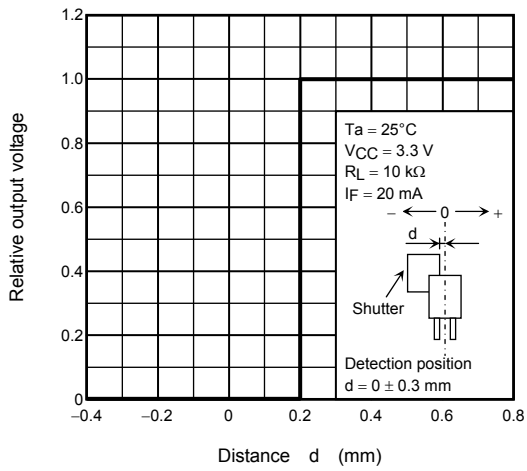

TLP1033A(F) Detection position characteristic (2) (typ.)

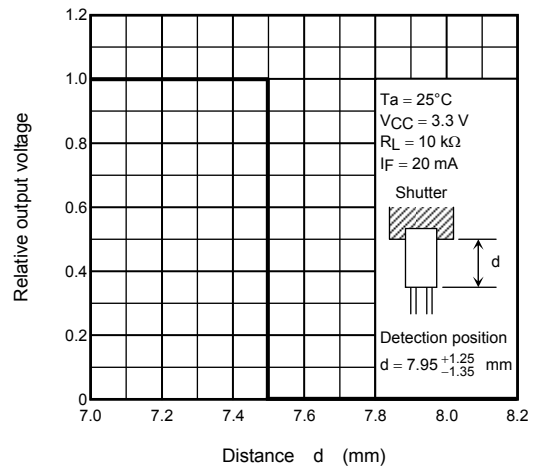

Relative Positioning of Shutter and Device

For normal operation, position the shutter and the device as shown in the figure below. Take into account the detection direction characteristic and switching time of the device in determining the shutter slit width and pitch.

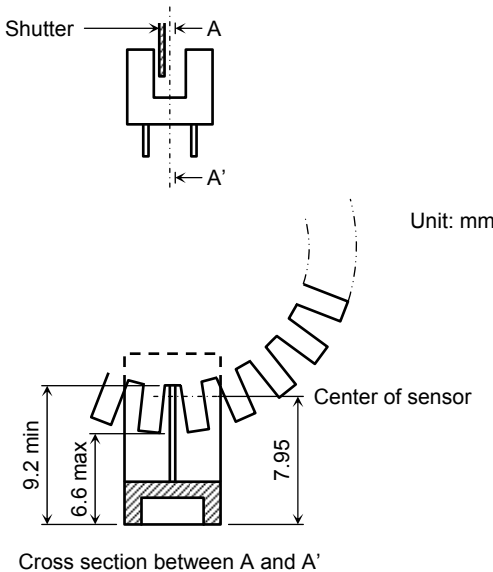

RESTRICTIONS ON PRODUCT USE

20070701-EN

- The information contained herein is subject to change without notice.
- TOSHIBA is continually working to improve the quality and reliability of its products. Nevertheless, semiconductor devices in general can malfunction or fail due to their inherent electrical sensitivity and vulnerability to physical stress. It is the responsibility of the buyer, when utilizing TOSHIBA products, to comply with the standards of safety in making a safe design for the entire system, and to avoid situations in which a malfunction or failure of such TOSHIBA products could cause loss of human life, bodily injury or damage to property.
In developing your designs, please ensure that TOSHIBA products are used within specified operating ranges as set forth in the most recent TOSHIBA products specifications. Also, please keep in mind the precautions and conditions set forth in the "Handling Guide for Semiconductor Devices," or "TOSHIBA Semiconductor Reliability Handbook" etc.
- The TOSHIBA products listed in this document are intended for usage in general electronics applications (computer, personal equipment, office equipment, measuring equipment, industrial robotics, domestic appliances, etc.). These TOSHIBA products are neither intended nor warranted for usage in equipment that requires extraordinarily high quality and/or reliability or a malfunction or failure of which may cause loss of human life or bodily injury ("Unintended Usage"). Unintended Usage include atomic energy control instruments, airplane or spaceship instruments, transportation instruments, traffic signal instruments, combustion control instruments, medical instruments, all types of safety devices, etc.. Unintended Usage of TOSHIBA products listed in this document shall be made at the customer's own risk.
- The products described in this document shall not be used or embedded to any downstream products of which manufacture, use and/or sale are prohibited under any applicable laws and regulations.
- The information contained herein is presented only as a guide for the applications of our products. No responsibility is assumed by TOSHIBA for any infringements of patents or other rights of the third parties which may result from its use. No license is granted by implication or otherwise under any patents or other rights of TOSHIBA or the third parties.
- GaAs(Gallium Arsenide) is used in this product. The dust or vapor is harmful to the human body. Do not break, cut, crush or dissolve chemically.
- Please contact your sales representative for product-by-product details in this document regarding RoHS compatibility. Please use these products in this document in compliance with all applicable laws and regulations that regulate the inclusion or use of controlled substances. Toshiba assumes no liability for damage or losses occurring as a result of noncompliance with applicable laws and regulations.