

TLPGE262

Product Features -

- InGaAlP Technology
- 3mm Diameter T-1 Package
- High Luminous Intensity
- Water Clear Lens
- Fast Response Time, Capable of Pulse Operation

MAXIMUM RATINGS (Ta = 25°C)

CHARACTERISTIC	SYMBOL	RATING	UNIT
Forward Current	I_F	50	mA
Reverse Voltage	V_R	4	V
Power Dissipation	P_D	140	mW
Operating Temperature	T_{opr}	-30 ~ 85	°C
Storage Temperature	T_{stg}	-40 ~ 120	°C

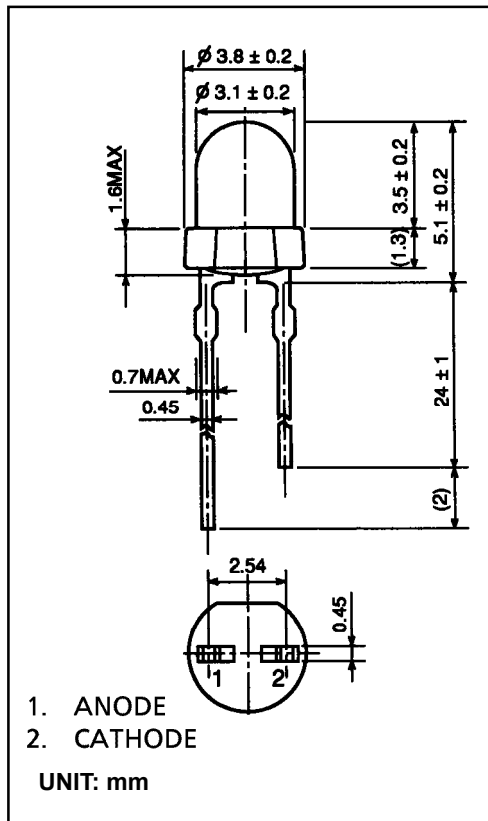

OPTO-ELECTRICAL CHARACTERISTICS (Ta = 25°C)

CHARACTERISTIC	SYMBOL	TEST CONDITION	MIN.	TYP.	MAX.	UNIT
Forward Voltage	V_F	$I_F = 20\text{mA}$	—	2.27	2.8	V
Reverse Current	I_R	$V_R = 4\text{V}$	—	—	50	μA
Luminous Intensity	I_v	$I_F = 20\text{mA}$	15	45	—	mcd
Viewing Angle	$2\theta_{1/2}$	—	—	62	—	°
Peak Wavelength	λ_p	$I_F = 20\text{mA}$	—	562	—	nm
Dominant Wavelength	λ_d	$I_F = 20\text{mA}$	—	558	—	nm
Spectral Line Half Width	$\Delta\lambda$	$I_F = 20\text{mA}$	—	11	—	nm

* Luminous Ranks: (K : 18-36mcd), (L : 32-64mcd), (M : 56-112mcd) Upper and lower limit tolerance $\pm 15\%$
Available in One Bin Combination: (KL)

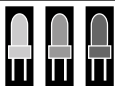

marktech
optoelectronics

120 Broadway • Menands, New York 12204

Toll Free: **(800) 98-4LEDS** • Fax: (518) 432-7454

TLPGE262 Graphs -

