

AMPLIFIER FOR THREE-WIRE ANALOG ELECTRET MICROPHONES

FEATURES

- **Output Voltage Noise (A Weighted):**
–89 dBV (Typ)
- **Low Supply Current:** 70 μ A (Typ)
- **Wide Supply Voltage Range:** 1.7 V to 5 V
- **PSRR:** 70 dB (Typ)
- **Signal-to-Noise Ratio:** 61 dB (Typ)
- **Input Capacitance:** 2 pF (Typ)
- **Input Impedance:** >100 Ω (Typ)
- **Output Impedance:** <100 Ω (Typ)
- **Maximum Input Signal:** 170 mV_{PP} (Typ)

APPLICATIONS

- **Mobile Communications, Bluetooth**
- **Automotive Accessories**
- **Cellular Phones**
- **PDA's**
- **Accessory Microphone Products**

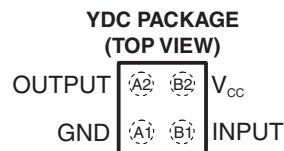

DESCRIPTION/ORDERING INFORMATION

The TLV1018 is an audio amplifier for small-form-factor electret microphones and is designed to replace the currently implemented JFET preamplifiers. The TLV1018 is ideal for extended battery-life applications, such as a Bluetooth™ communication link. The addition of a third pin to an electret microphone that incorporates a TLV1018 allows for a dramatic reduction in supply current compared to a JFET-equipped electret microphone. Microphone supply current is reduced to 70 μ A, assuring longer battery life.

The TLV1018 is specified for supply voltages from 1.7 V to 5 V and has fixed voltage gains of 15 dB and 25 dB. It offers low output impedance over the voice bandwidth, excellent power supply rejection (PSRR), and stability over temperature.

The TLV1018 is offered in a space-saving four-terminal ultra-thin lead-free package (YDC) and is ideally suited for the form factor of miniature electret microphone packages. The TLV1018 is characterized for operation over a free-air temperature range of –40°C to 85°C.

ORDERING INFORMATION⁽¹⁾

T_A	A_V	PACKAGE ⁽²⁾		ORDERABLE PART NUMBER	TOP-SIDE MARKING
–40°C to 85°C	15 dB	NanoStar™ WCSP (DSBGA) – YDC	Reel of 3000	TLV1018-15YDCR	Y28
	25 dB			TLV1018-25YDCR	YW8

(1) For the most current package and ordering information, see the Package Option Addendum at the end of this document, or see the TI web site at www.ti.com.

(2) Package drawings, thermal data, and symbolization are available at www.ti.com/packaging.



Please be aware that an important notice concerning availability, standard warranty, and use in critical applications of Texas Instruments semiconductor products and disclaimers thereto appears at the end of this data sheet.

Bluetooth is a trademark of Bluetooth SIG.

FUNCTIONAL BLOCK DIAGRAM

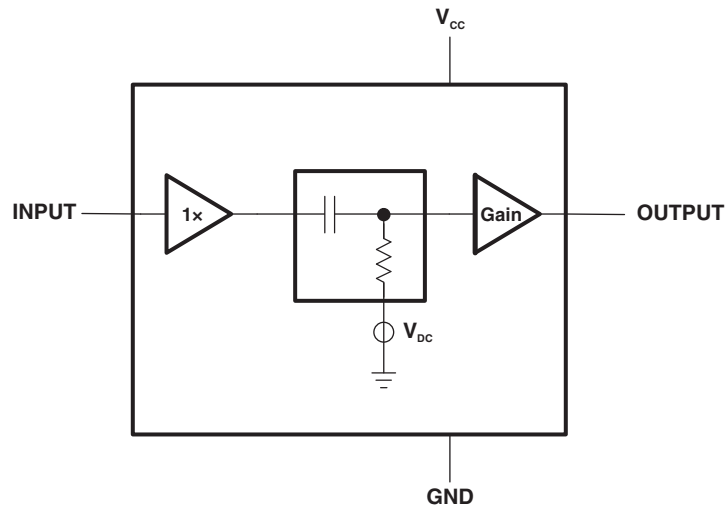

ABSOLUTE MAXIMUM RATINGS⁽¹⁾

over operating free-air temperature range (unless otherwise noted)

V_{CC}	Supply voltage	-0.3 V to 5.5 V
V_{IN}	Input voltage	-0.3 V to 0.3 V
θ_{JA}	Thermal impedance, junction to free air ⁽²⁾	230.47°C/W
T_A	Operating free-air temperature range	-40°C to 85°C
T_{stg}	Storage temperature range	-65°C to 150°C

- (1) Stresses beyond those listed under *Absolute Maximum Ratings* may cause permanent damage to the device. These are stress ratings only, and functional operation of the device at these or any other conditions beyond those indicated under *Recommended Operating Conditions* is not implied. Exposure to absolute-maximum-rated conditions for extended periods may affect device reliability.
- (2) Package thermal impedance is calculated according to JESD 51-7.

RECOMMENDED OPERATING CONDITIONS

		MIN	MAX	UNIT
V_{CC}	Supply voltage	1.7	5	V
T_A	Operating free-air temperature	-40	85	°C

ELECTRICAL CHARACTERISTICS

over recommended operating conditions (unless otherwise noted)

PARAMETER		TEST CONDITIONS		T _J	MIN	TYP	MAX	UNIT	
I _{CC}	Supply current	V _{IN} = GND		25°C		70	90	μA	
				Full range			100		
SNR	Signal-to-noise ratio	V _{CC} = 1.7 V, V _{IN} = 18 mV _{PP} , f = 1 kHz	TLV1018-15	25°C		61		dB	
			TLV1018-25	25°C		61			
		V _{CC} = 5 V, V _{IN} = 18 mV _{PP} , f = 1 kHz	TLV1018-15	25°C		61			
			TLV1018-25	25°C		62			
PSRR	Power-supply rejection ratio	V _{CC} = 1.7 V to 5 V		TLV1018-15	25°C	55	70	dB	
				Full range		50			
				TLV1018-25	25°C	55	65		
				Full range	50				
V _{IN}	Input voltage	f = 1 kHz, THD+N < 1%		TLV1018-15	25°C		170	mV _{PP}	
				TLV1018-25	25°C		60		
f _{LOW}	Lower –3-dB roll-off frequency	R _{SOURCE} = 50 Ω, V _{IN} = 18 mV _{PP}		25°C		70		Hz	
f _{HIGH}	Upper –3-dB roll-off frequency	R _{SOURCE} = 50 Ω, V _{IN} = 18 mV _{PP}		TLV1018-15	25°C		75	kHz	
				TLV1018-25	25°C		75		
e _n	Output noise	A-weighted		TLV1018-15	25°C		–89	dBV	
				TLV1018-25	25°C		–80		
V _{OUT}	Output voltage	V _{IN} = GND		TLV1018-15	25°C		500	mV	
				Full range		250	750		
				TLV1018-25	25°C		600		
					Full range	400	800		
Z _{OUT}	Output impedance	f = 1 kHz		25°C		<100		Ω	
I _{OUT}	Output current	V _{CC} = 1.7 V, V _{OUT} = 1.7 V, Sinking		25°C	0.9	2.3	mA		
				Full range		0.5			
		V _{CC} = 1.7 V, V _{OUT} = 0 V, Sourcing		25°C	0.3	1.5			
				Full range		0.2			
		V _{CC} = 5 V, V _{OUT} = 1.7 V, Sinking		25°C	0.9	2.9			
				Full range		0.5			
		V _{CC} = 5 V, V _{OUT} = 0 V, Sourcing		25°C	0.4	2.6			
				Full range		0.1			
THD	Total harmonic distortion	f = 1 kHz, V _{IN} = 18 mV _{PP}		TLV1018-15	25°C		0.13	%	
				TLV1018-25	25°C		0.2		
C _{IN}	Input capacitance					2		pF	
Z _{IN}	Input impedance					>100		MΩ	
A _V	Gain	f = 1 kHz, V _{IN} = 18 mV _{PP}		TLV1018-15	25°C	14.8	15.4	16	dB
					Full range		14	17	
				TLV1018-25	25°C	24.8	25.5	26.2	
					Full range		24	27	

TYPICAL CHARACTERISTICS

SUPPLY CURRENT
vs
SUPPLY VOLTAGE

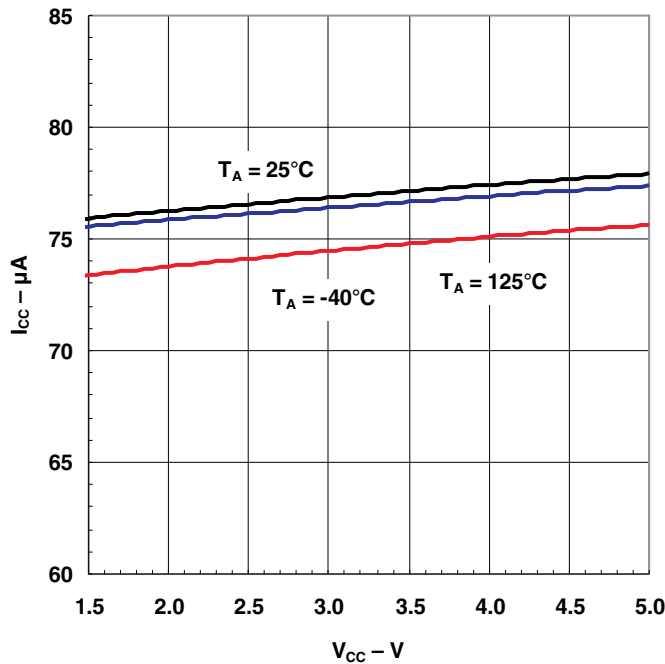

CLOSED LOOP GAIN AND PHASE
vs
FREQUENCY

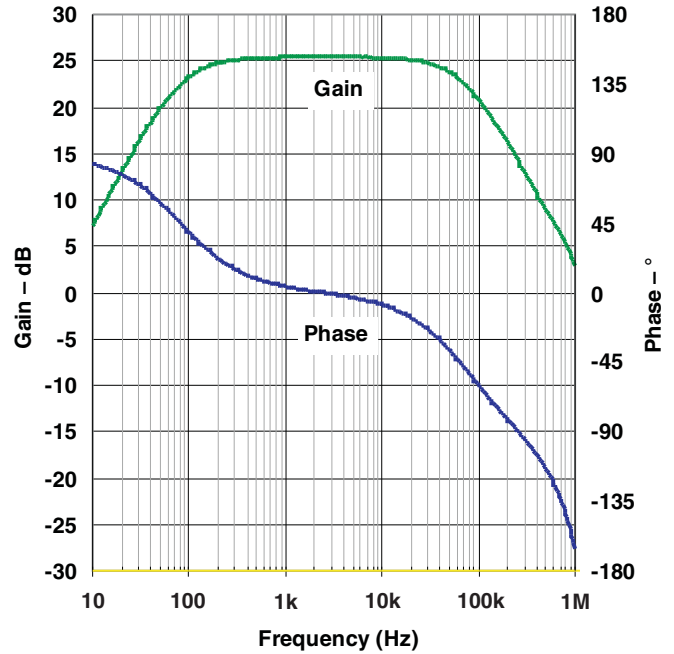

POWER SUPPLY REJECTION RATIO
vs
FREQUENCY

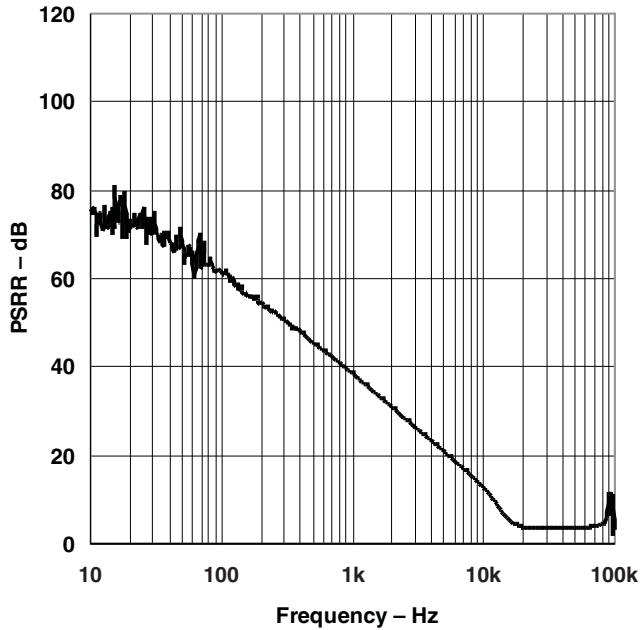

TOTAL HARMONIC DISTORTION + NOISE
vs
FREQUENCY

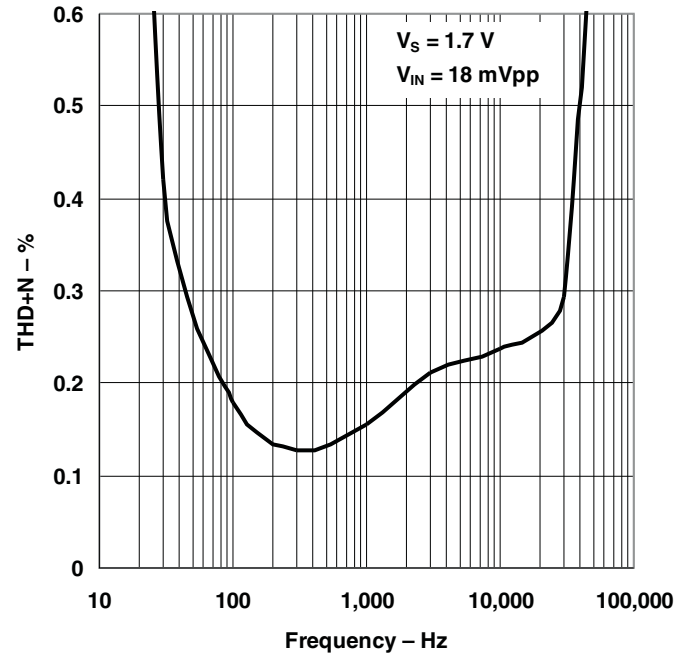

TYPICAL CHARACTERISTICS (continued)

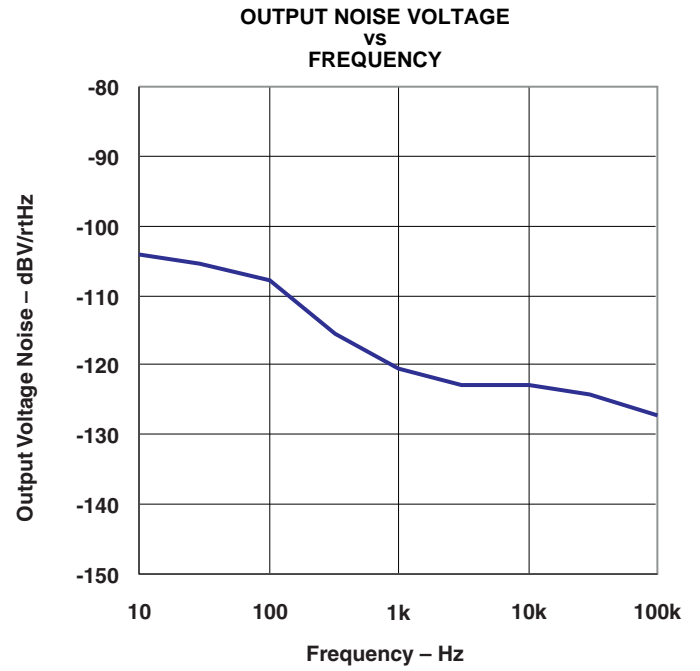
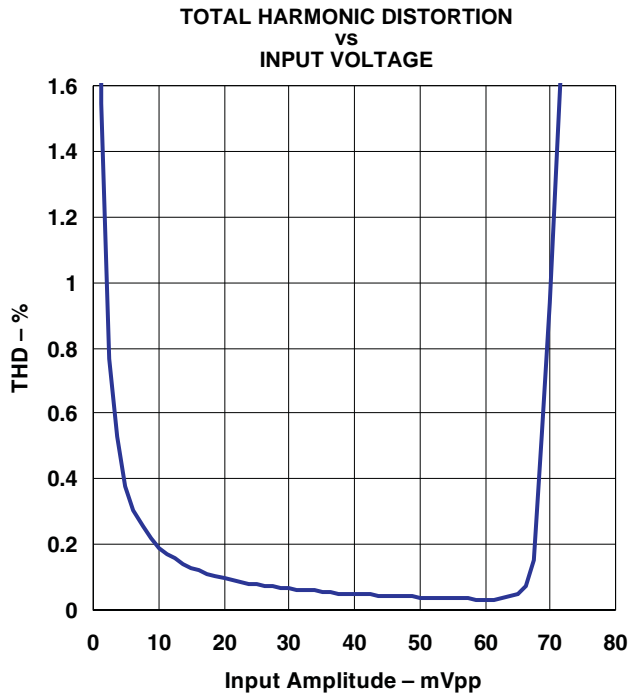

APPLICATION INFORMATION

Low Current

The TLV1018 has a low supply current, which allows for a longer battery life. The low supply current of 70 μA makes this amplifier optimal for microphone applications that need to be always on.

Built-In Gain

The TLV1018 is offered in the space-saving YDC package, which fits perfectly into the metal can of a microphone. This allows the TLV1018 to be placed on the PCB inside the microphone.

The bottom side of the PCB has pins that connect the supply voltage to the amplifier and make the output available. The input of the amplifier is connected to the microphone via the PCB.

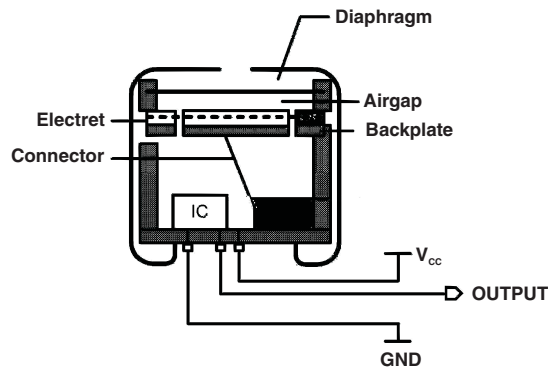

Figure 1. Built-In Gain

A-Weighted Filter

The human ear has a frequency range from 20 Hz to about 20 kHz. Within this range the sensitivity of the human ear is not equal for each frequency. To approach the hearing response, weighting filters are introduced. One of those filters is the A-weighted filter.

The A-weighted filter is usually used in signal-to-noise ratio measurements, where sound is compared to device noise. It improves the correlation of the measured data to the signal-to-noise ratio perceived by the human ear.

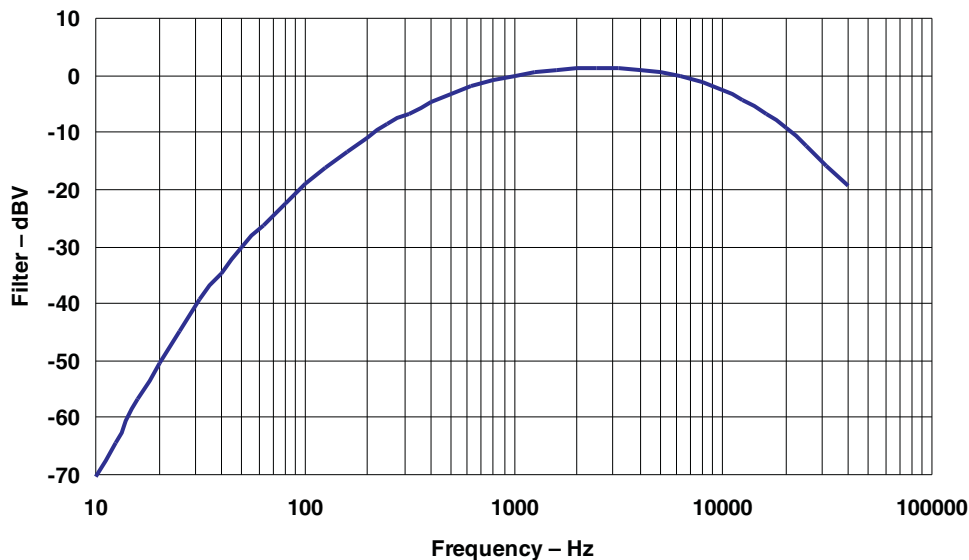

Figure 2. A-Weighted Filter

Measuring Noise and SNR

The overall noise of the TLV1018 is measured within the frequency band from 10 Hz to 22 kHz using an A-weighted filter. The input of the TLV1018 is connected to ground with a 5-pF capacitor.

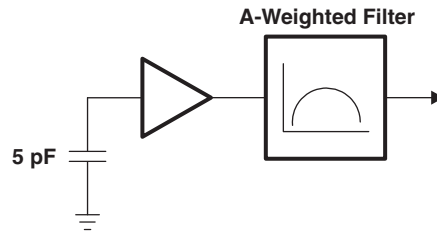

Figure 3. Noise Measurement

The signal-to-noise ratio (SNR) is measured with a 1-kHz input signal of 18 mV_{PP} using an A-weighted filter. This represents a sound pressure level (SPL) of 94 dB SPL. No input capacitor is connected.

Sound Pressure Level

The volume of sound applied to a microphone is usually stated as the pressure level with respect to the threshold of hearing of the human ear. The sound pressure level (SPL) in decibels is defined by:

$$\text{Sound pressure level (dB)} = 20 \log P_m/P_0$$

Where P_m is the measured sound pressure, and P_0 is the threshold of hearing (20 μ Pa)

To calculate the resulting output voltage of the microphone for a given SPL, the sound pressure in dB SPL needs to be converted to the absolute sound pressure in dB Pa. This is the sound pressure level in decibels, which is referred to as 1 Pascal (Pa).

The conversion is given by:

$$\text{dB Pa} = \text{dB SPL} + 20 \log 20 \mu\text{Pa}$$

$$\text{dB Pa} = \text{dB SPL} - 94 \text{ dB}$$

Translation from absolute sound pressure level to a voltage is specified by the sensitivity of the microphone. A conventional microphone has a sensitivity of -44 dBV/Pa.

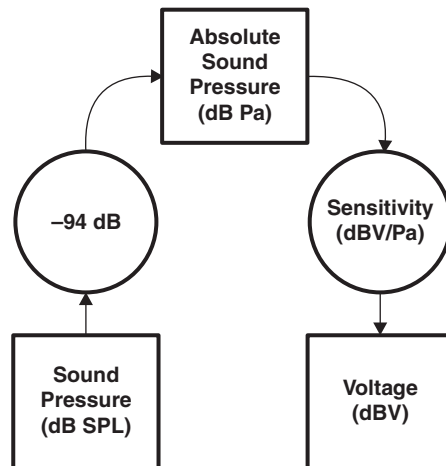

Figure 4. dB SPL to dBV Conversion

Example: Busy traffic is 70 dB SPL

$$V_{OUT} = 70 - 94 - 44 = -68 \text{ dBV}$$

This is equivalent to 1.13 mV_{PP}.

Because the TLV1018-15 has a gain of 5.6 (15 dB) over the JFET, the output voltage of the microphone is 6.35 mV_{pp}. By replacing the JFET with the TLV1018-15, the sensitivity of the microphone is –29 dBV/Pa (–44 + 15).

Low-Frequency Cut-Off Filter

To reduce noise on the output of the microphone, a low-cut filter is implemented in the TLV1018. This filter reduces the effect of wind and handling noise.

It is also helpful to reduce the proximity effect in directional microphones. This effect occurs when the sound source is very close to the microphone. The lower frequencies are amplified, which gives a bass sound. This amplification can cause an overload, which results in a distortion of the signal.

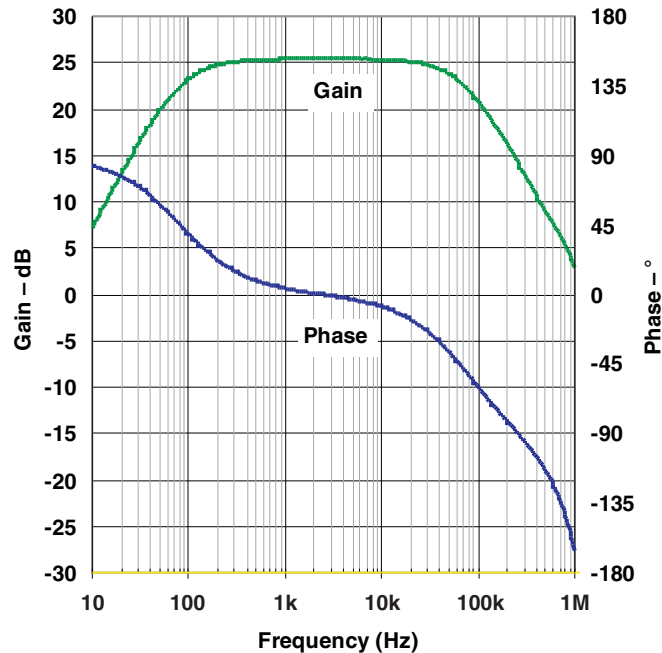

Figure 5. Gain vs. Frequency

The TLV1018 is optimized to be used in audio-band applications. The TLV1018 provides a flat gain response within the audio band and offers linearity and excellent temperature stability.

Advantage of Three Pins

The TLV1018 ECM solution has three pins, instead of the two pins provided in the case of a JFET solution. The third pin provides the advantage of a low supply current, high PSRR, and eliminates the need for additional components.

Noise pick-up by a microphone in a cell phone is a well known problem. A conventional JFET circuit is sensitive for noise pick-up because of its high output impedance. The output impedance is usually around 2.2 k Ω . By providing separate output and supply pins a much lower output impedance is achieved and therefore is less sensitive to noise pick-up.

RF noise is one of the noises caused by non-linear behavior. The non-linear behavior of the amplifier at high frequencies, well above the usable bandwidth of the device, causes AM demodulation of high-frequency signals. The AM modulation contained in such signals folds back into the audio band, thereby disturbing the intended microphone signal. The GSM signal of a cell phone is such an AM-modulated signal. The modulation frequency of 216 Hz and its harmonics can be observed in the audio band. This type of noise is called bumblebee noise.

External Pre-Amplifier Application

The TLV1018 can also be used outside of an ECM as a space saving external preamplifier. In this application, the TLV1018 follows a phantom biased JFET microphone in the circuit. This is shown in Figure 6. The input of the TLV1018 is connected to the microphone via the 2.2- μ F capacitor. The advantage of this circuit over one with only a JFET microphone are the additional gain and the high-pass filter supplied by the TLV1018. The high-pass filter makes the output signal more robust and less sensitive to low frequency disturbances. In this configuration, the TLV1018 should be placed as close as possible to the microphone.

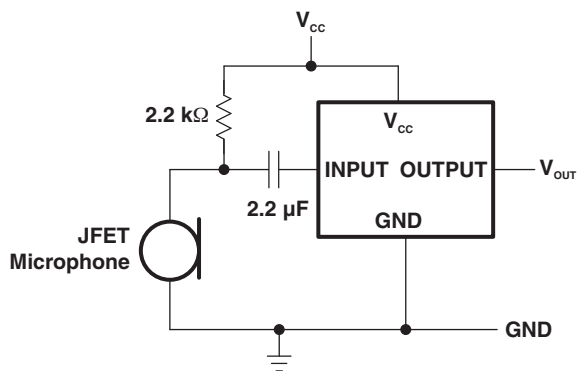

Figure 6. External Preamplifier

PACKAGING INFORMATION

Orderable Device	Status ⁽¹⁾	Package Type	Package Drawing	Pins	Package Qty	Eco Plan ⁽²⁾	Lead/Ball Finish	MSL Peak Temp ⁽³⁾
TLV1018-15YDCR	ACTIVE	DSBGA	YDC	4	3000	Green (RoHS & no Sb/Br)	SNAGCU	Level-1-260C-UNLIM
TLV1018-25YDCR	ACTIVE	DSBGA	YDC	4	3000	Green (RoHS & no Sb/Br)	SNAGCU	Level-1-260C-UNLIM

⁽¹⁾ The marketing status values are defined as follows:

ACTIVE: Product device recommended for new designs.

LIFEBUY: TI has announced that the device will be discontinued, and a lifetime-buy period is in effect.

NRND: Not recommended for new designs. Device is in production to support existing customers, but TI does not recommend using this part in a new design.

PREVIEW: Device has been announced but is not in production. Samples may or may not be available.

OBSOLETE: TI has discontinued the production of the device.

⁽²⁾ Eco Plan - The planned eco-friendly classification: Pb-Free (RoHS), Pb-Free (RoHS Exempt), or Green (RoHS & no Sb/Br) - please check <http://www.ti.com/productcontent> for the latest availability information and additional product content details.

TBD: The Pb-Free/Green conversion plan has not been defined.

Pb-Free (RoHS): TI's terms "Lead-Free" or "Pb-Free" mean semiconductor products that are compatible with the current RoHS requirements for all 6 substances, including the requirement that lead not exceed 0.1% by weight in homogeneous materials. Where designed to be soldered at high temperatures, TI Pb-Free products are suitable for use in specified lead-free processes.

Pb-Free (RoHS Exempt): This component has a RoHS exemption for either 1) lead-based flip-chip solder bumps used between the die and package, or 2) lead-based die adhesive used between the die and leadframe. The component is otherwise considered Pb-Free (RoHS compatible) as defined above.

Green (RoHS & no Sb/Br): TI defines "Green" to mean Pb-Free (RoHS compatible), and free of Bromine (Br) and Antimony (Sb) based flame retardants (Br or Sb do not exceed 0.1% by weight in homogeneous material)

⁽³⁾ MSL, Peak Temp. -- The Moisture Sensitivity Level rating according to the JEDEC industry standard classifications, and peak solder temperature.

Important Information and Disclaimer:The information provided on this page represents TI's knowledge and belief as of the date that it is provided. TI bases its knowledge and belief on information provided by third parties, and makes no representation or warranty as to the accuracy of such information. Efforts are underway to better integrate information from third parties. TI has taken and continues to take reasonable steps to provide representative and accurate information but may not have conducted destructive testing or chemical analysis on incoming materials and chemicals. TI and TI suppliers consider certain information to be proprietary, and thus CAS numbers and other limited information may not be available for release.

In no event shall TI's liability arising out of such information exceed the total purchase price of the TI part(s) at issue in this document sold by TI to Customer on an annual basis.

MECHANICAL DATA

YDC (S-XBGA-N4)

DIE-SIZE BALL GRID ARRAY

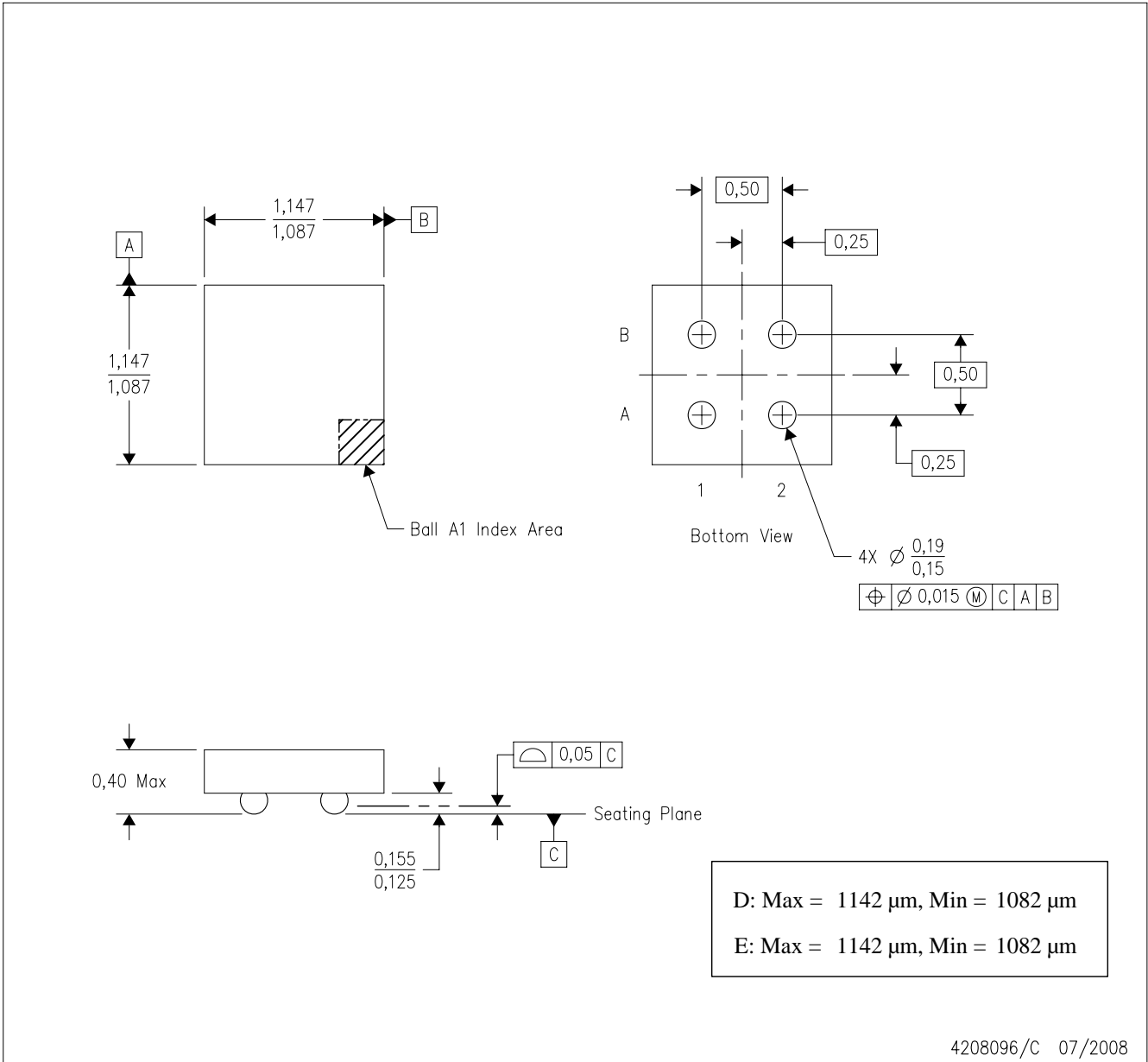

- NOTES:
- A. All linear dimensions are in millimeters. Dimensioning and tolerancing per ASME Y14.5M-1994.
 - B. This drawing is subject to change without notice.
 - C. NanoFree™ package configuration.
 - D. This package contains lead-free solder balls.

NanoFree is a trademark of Texas Instruments.

IMPORTANT NOTICE

Texas Instruments Incorporated and its subsidiaries (TI) reserve the right to make corrections, modifications, enhancements, improvements, and other changes to its products and services at any time and to discontinue any product or service without notice. Customers should obtain the latest relevant information before placing orders and should verify that such information is current and complete. All products are sold subject to TI's terms and conditions of sale supplied at the time of order acknowledgment.

TI warrants performance of its hardware products to the specifications applicable at the time of sale in accordance with TI's standard warranty. Testing and other quality control techniques are used to the extent TI deems necessary to support this warranty. Except where mandated by government requirements, testing of all parameters of each product is not necessarily performed.

TI assumes no liability for applications assistance or customer product design. Customers are responsible for their products and applications using TI components. To minimize the risks associated with customer products and applications, customers should provide adequate design and operating safeguards.

TI does not warrant or represent that any license, either express or implied, is granted under any TI patent right, copyright, mask work right, or other TI intellectual property right relating to any combination, machine, or process in which TI products or services are used. Information published by TI regarding third-party products or services does not constitute a license from TI to use such products or services or a warranty or endorsement thereof. Use of such information may require a license from a third party under the patents or other intellectual property of the third party, or a license from TI under the patents or other intellectual property of TI.

Reproduction of TI information in TI data books or data sheets is permissible only if reproduction is without alteration and is accompanied by all associated warranties, conditions, limitations, and notices. Reproduction of this information with alteration is an unfair and deceptive business practice. TI is not responsible or liable for such altered documentation. Information of third parties may be subject to additional restrictions.

Resale of TI products or services with statements different from or beyond the parameters stated by TI for that product or service voids all express and any implied warranties for the associated TI product or service and is an unfair and deceptive business practice. TI is not responsible or liable for any such statements.

TI products are not authorized for use in safety-critical applications (such as life support) where a failure of the TI product would reasonably be expected to cause severe personal injury or death, unless officers of the parties have executed an agreement specifically governing such use. Buyers represent that they have all necessary expertise in the safety and regulatory ramifications of their applications, and acknowledge and agree that they are solely responsible for all legal, regulatory and safety-related requirements concerning their products and any use of TI products in such safety-critical applications, notwithstanding any applications-related information or support that may be provided by TI. Further, Buyers must fully indemnify TI and its representatives against any damages arising out of the use of TI products in such safety-critical applications.

TI products are neither designed nor intended for use in military/aerospace applications or environments unless the TI products are specifically designated by TI as military-grade or "enhanced plastic." Only products designated by TI as military-grade meet military specifications. Buyers acknowledge and agree that any such use of TI products which TI has not designated as military-grade is solely at the Buyer's risk, and that they are solely responsible for compliance with all legal and regulatory requirements in connection with such use.

TI products are neither designed nor intended for use in automotive applications or environments unless the specific TI products are designated by TI as compliant with ISO/TS 16949 requirements. Buyers acknowledge and agree that, if they use any non-designated products in automotive applications, TI will not be responsible for any failure to meet such requirements.

Following are URLs where you can obtain information on other Texas Instruments products and application solutions:

Products		Applications	
Amplifiers	amplifier.ti.com	Audio	www.ti.com/audio
Data Converters	dataconverter.ti.com	Automotive	www.ti.com/automotive
DLP® Products	www.dlp.com	Communications and Telecom	www.ti.com/communications
DSP	dsp.ti.com	Computers and Peripherals	www.ti.com/computers
Clocks and Timers	www.ti.com/clocks	Consumer Electronics	www.ti.com/consumer-apps
Interface	interface.ti.com	Energy	www.ti.com/energy
Logic	logic.ti.com	Industrial	www.ti.com/industrial
Power Mgmt	power.ti.com	Medical	www.ti.com/medical
Microcontrollers	microcontroller.ti.com	Security	www.ti.com/security
RFID	www.ti-rfid.com	Space, Avionics & Defense	www.ti.com/space-avionics-defense
RF/IF and ZigBee® Solutions	www.ti.com/lprf	Video and Imaging	www.ti.com/video
		Wireless	www.ti.com/wireless-apps