

PULNiX TM-1402CL



The TM-1402 is a miniature, high-resolution (1.4 Mpixels) monochrome progressive scan CCD camera. The 1/2" format interline transfer CCD (ICX205AL) permits full vertical and horizontal resolution of high-speed shuttered images. Applications for the TM-1402 include machine vision, medical imaging, intelligent transportation systems, high-definition graphics, gauging, character recognition, robotics, and surveillance.

- 1/2" progressive scan IT CCD imager (ICX205AL)
- 1392(H) x 1040(V) @ 30 fps
- 4.65 μM square pixels
- Color version (RGB Bayer CFA) is available as TMC-1402‡
- LVDS versions order TM-1402 and TMC-1402
- Miniature 44x44x64 mm housing with high-rel connector
- Camera Link output and analog output
- 30/15 frames per second selectable
- Maximum dynamic range control with PULNiX-exclusive, patent-pending built-in look-up table
- Image center partial scan (500, 250 lines)
- Full-frame shutter to 1/16,000 sec.
- Asynchronous reset, no-delay shutter with pulse-width exposure control
- RS-232 external control
- Adjustable back-focus - CL versions only

‡ For more information see the Color AccuPIXEL data sheet

TM-1402 SPECIFICATIONS

Imager	1/2" progressive scan interline transfer CCD
Active Area	6.47mm x 4.84mm
Active Pixels	1392 (H) x 1040 (V)
Cell Size	4.65 μm x 4.65 μm
Display Mode (Active Pixels)	1392 (H) x 1040 (V) @ 30/15 Hz selectable 1392 (H) x 500 (V) @ partial scan 1392 (H) x 250 (V) @ partial scan
Sync*	Internal/External auto switch HD/VD, 4.0 Vp-p impedance 4.7Ω VD=15 / 30 Hz ± 2%, non-interlace HD=15.55 / 31.09 kHz ± 2%
Data Clock Output	50.00 / 25.00 MHz
Resolution	Digital: 1392 (H) x 1040 (V) Analog: over 900 TV lines (H) x 800 TV lines (V)
S/N Ratio	52dB min.
Min. Illumination	1.0 lux, f=1.4 (no shutter) @ 30 fps
Video Output	Analog: 714 mV, 75Ω (900 mV white clip) Camera Link Digital output: 8-bit RS-644
Gamma	Programmable LUT (1.0 std)
Lens Mount	C-mount (use >1/2" format lenses)
Power Requirement	12V DC ± 10%, 380 mA (typical at 25° C)
Operating Temp.†	-10° C to 50° C
Vibration	7 Grms (10 Hz to 2000 Hz) Random
Shock	70G
Size (W x H x L)	44mm x 44mm x 64mm (1.73" x 1.73" x 2.51")
Weight	133 grams, 4.7 oz (without tripod)

MUST BE ORDERED SEPARATELY

Optional Functions	
Optional Accessories	
I/O	CL 26CL-02-26 RS-644 30DG-02 digital output cable (LVDS only) CS-232E serial communication kit (LVDS only)
Power Cable	12P-02S power cable with open leads
Power Supply	PD-12UUP series (includes power connector)

* External sync only at 30 fps.

† Image quality will degrade with increasing temperature.

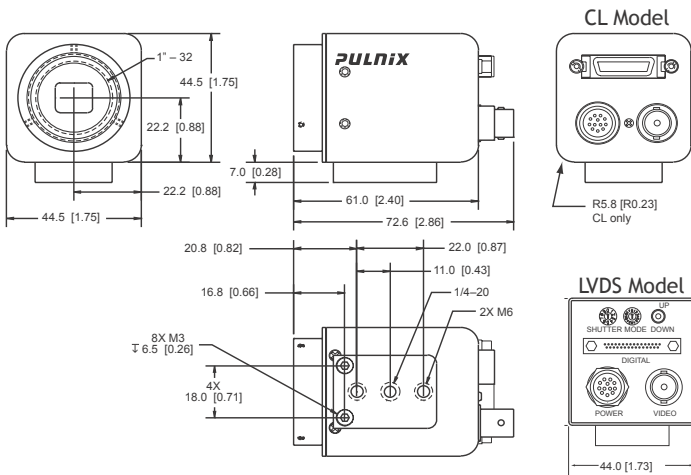

Graphical User Interface

A user-friendly graphical user interface (GUI) is provided in the CS-232E kit. This interface allows users to control the following functions of the TM-1402 camera:

- Shutter control for manual async. and pulse width control
- Gain control
- A/D reference voltages control for Vtop and Vbottom
- Save settings
- Load settings
- Report settings
- LUT setting and graphic display
- Scanning mode selection and Option selections

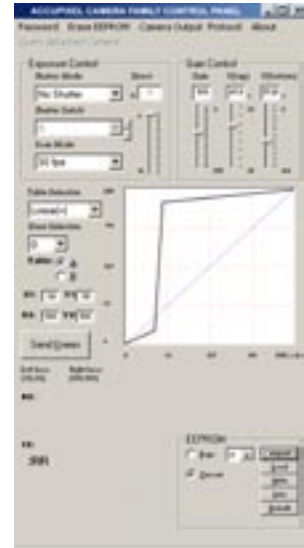

12-Pin Connector

1 GND (power)	7 VD in
2 +12V	8 GND
3 GND (analog)	9 HD in
4 Video out	10 RXD(RS232)*
5 GND (digital)	11 N/C
6 VINIT in	12 TXD(RS232)*

* LVDS only

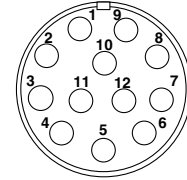

Shutter Speeds

	Manual	Async
0	no shutter (1/30)	no shutter (1/30)
1	1/60	1/16,000
2	1/125	1/8,000
3	1/250	1/4,000
4	1/500	1/2,000
5	1/1,000	1/1,000
6	1/2,000	1/500
7	1/4,000	1/250
8	1/8,000	1/125
9	1/16,000	Ext. pulse width control

(For 15 fps mode, the shutter speed is halved)

LVDS Models Only

Mode Switch	Up/Down Switch	Functions
0 Switch Disabled	Switch Disabled	None
1 Set Gain	Up / Down	Change gain
2 Set Vtop (A/D)	Up / Down	Change A/D ref. top
3 Set Vbottom (A/D)	Up / Down	Change A/D ref bottom
4 Gain Selection #1	Up: 9dB, Down: 12dB	Lower gain selection
5 Gain Selection #2	Up: 18dB, Down: 22dB	Higher gain selection
6 Linear LUT	Up	Back to linear table
7 Knee Selection	Up / Down (Scroll)	Scroll 8 different LUTs
8 Async Reset Mode	Up: Normal, Dwn: Async	Async and normal shutter
9 Factory Default Recall	Up / Down: Recall	Factory setting
A Power up Setting	Up: Recall, Dwn: Save	Power up page setting
B User Page Storage#1	Up: Recall, Dwn: Save	User page storage setting
C User Page Storage#2	Up: Recall, Dwn: Save	User page storage setting
D Direct Shutter Control	Up / Down	Increment by 1H
E Scan Format2	Up: 500, Dwn: 250	Partial selection
F Scan Format1	Up: 30 fps, Dwn: 15 fps	Custom option scanning

JAI A-S, Denmark
Phone +45 4457 8888
www.jai.com

JAI UK Ltd., England
Phone: +44 (0) 189 582 1481
www.jai.com

JAI Corporation, Japan
Phone: +81 045 440 0154
www.jai-corp.co.jp

JAI PULNiX, Germany
Phone +49-(0) 60 55-93 79-10
www.jaipulnix.com

JAI PULNiX Inc., USA
1330 Orleans Drive
Sunnyvale
CA 94089
USA

Phone +1 408-747-0300
(toll-free) 1 800 445 5444
Fax +1 408 747 0660
www.jaipulnix.com

JAI
PULNiX
www.jaipulnix.com