



MODEL NO. : TM017FDH02

ISSUED DATE: 2009-06-02

VERSION : Ver 2.0

- Preliminary Specification
- Final Product Specification

Customer : _____

Approved by	Notes

SHANGHAI TIANMA Confirmed :

Prepared by	Checked by	Approved by
张振英 2009-06-03		刘庆 09.6.3



Table of Contents

Coversheet.....	1
Table of Contents.....	2
Record of Revision.....	3
1 General Specifications	4
2 Input/Output Terminals	5
3 Absolute Maximum Ratings	6
4 Electrical Characteristics.....	6
5 Timing Chart.....	9
6 Optical Characteristics	14
7 Environmental / Reliability Test	18
8 Mechanical Drawing.....	19
9 Packing Drawing	20
10 Precautions For Use of LCD Modules	21



1 General Specifications

	Feature	Spec
Display Spec.	Size	1.77 inch
	Resolution	128(RGB) x 160
	Interface	CPU 8bits
	Color Depth	65/262K
	Technology Type	a-Si
	Pixel Pitch (mm)	0.219x0.219
	Pixel Configuration	R.G.B. Vertical Stripe
	Display Mode	TM with Normally White
	Surface Treatment(Up Polarizer)	Clear Type(3H)
	Viewing Direction	6 o'clock
	Gray Scale Inversion Direction	12 o'clock
Mechanical Characteristics	LCM (W x H x D) (mm)	34.0x47.0x2.4
	Active Area(mm)	28.032x35.04
	With/Without TSP	Without TSP
	Weight (g)	6.2
	LED Numbers	2 LEDs
Electronic	Driver IC	HX8353-C

Note 1: Viewing direction for best image quality is different from TFT definition, there is a 180 degree shift.

Note 2 : Requirements on Environmental Protection: RoHS

Note 3 : LCM weight tolerance : +/- 5%



2 Input/Output Terminals

2.1 TFT LCD Panel

No	Symbol	I/O	Description	Comment
1	LED1+	P	LED anode	
2	LED2+	P	LED anode	
3	LED-	P	LED cathode	
4	NC	-	No Connection	
5	NRES	I	Reset Pin	
6	D15	I	Data input	
7	D14	I	Data input	
8	D13	I	Data input	
9	D12	I	Data input	
10	D11	I	Data input	
11	D10	I	Data input	
12	D9	I	Data input	
13	D8	I	Data input	
14	NC	-	No Connection	
15	NC	-	No Connection	
16	NC	-	No Connection	
17	NC	-	No Connection	
18	NC	-	No Connection	
19	NC	-	No Connection	
20	NC	-	No Connection	
21	NC	-	No Connection	
22	NRD	I	Read strobe	
23	NWR	I	Write strobe	
24	RS	I	Register select	
25	NCS	I	Chip select	
26	ID	O	ID Pin	
27	VCI	P	Power supply	
28	GND	P	Ground	
29	XR	P	Touch panel coordinate in the right side of envisage drawing	
30	YD	P	Touch panel coordinate in the down side of envisage drawing	
31	XL	P	Touch panel coordinate in the left side of envisage drawing	
32	YU	P	Touch panel coordinate in the up side of envisage drawing	
33	GND	P	Power Supply of I/O Interface	

Note2-1: I/O definition:

I----Input O---Output P----Power/Ground

The information contained herein is the exclusive property of SHANGHAI TIANMA MICRO-ELECTRONICS Corporation, and shall not be distributed, reproduced, or disclosed in whole or in part without prior written permission of SHANGHAI TIANMA MICRO-ELECTRONICS Corporation.



3 Absolute Maximum Ratings

3.1 Driving TFT LCD Panel

GND=0V, Ta = 25°C

Item	Symbol	Min	Max	Unit	Remark
Logic Supply Voltage	V _{CI}	-0.3	3.7	V	
Analog Supply Voltage	V _{CI}	-0.3	3.7	V	
Input Voltage	D15~D8,NCS,RS,NWR,NRD NRES	-0.3	V _{CI} +0.3	V	
Back Light Forward Current	I _{LED}		20	mA	For each LED
Operating Temperature	T _{OPR}	-20	70	°C	
Storage Temperature	T _{STG}	-30	80	°C	

4 Electrical Characteristics

4.1 Driving TFT LCD Panel

GND=0V, Ta=25°C

Item	Symbol	Min	Typ	Max	Unit	Remark
Logic Supply Voltage	V _{CI}	2.3	2.8	3.3	V	
Analog Supply Voltage	V _{CI}	2.3	2.8	3.3	V	
Input Signal Voltage	Low Level	V _{IL}	-0.3	--	0.2xV _{CI}	D15~D8,NCS,RS,NWR,NRD NRES
	High Level	V _{IH}	0.8xV _{CI}	--	V _{CI}	
Output Signal Voltage	Low Level	V _{OL}	--	--	0.2xV _{CI}	ID
	High Level	V _{OH}	0.8xV _{CI}	--	V _{CI}	
(Panel+ LSI) Power Consumption	Black Mode (60Hz)	--	TBD	--	-	
	Standby Mode	--	TBD	--	--	
	Sleeping Mode	--	TBD	--	--	



4.2 Driving Backlight

Ta=25°C

Item	Symbol	Min	Typ	Max	Unit	Remark
Forward Current	I_F	--	15	--	mA	
Forward Current Voltage	V_F	--	3.2	--	V	
Backlight Power Consumption	W_{BL}	--	96	--	mW	

Note 1: The figure below shows the connection of backlight LED.

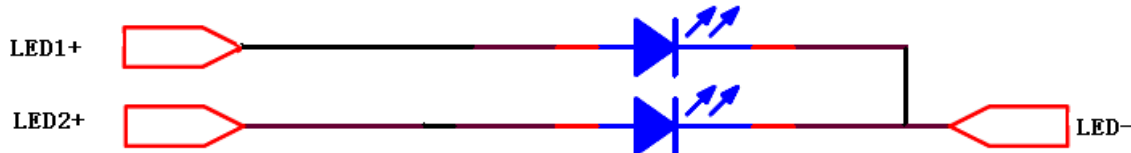

Note 2: One LED : $I_F = 15 \text{ mA}$, $V_F = 3.2 \text{ V}$

Note 3: The Life of LED : 20,000 hours



4.3 Block Diagram

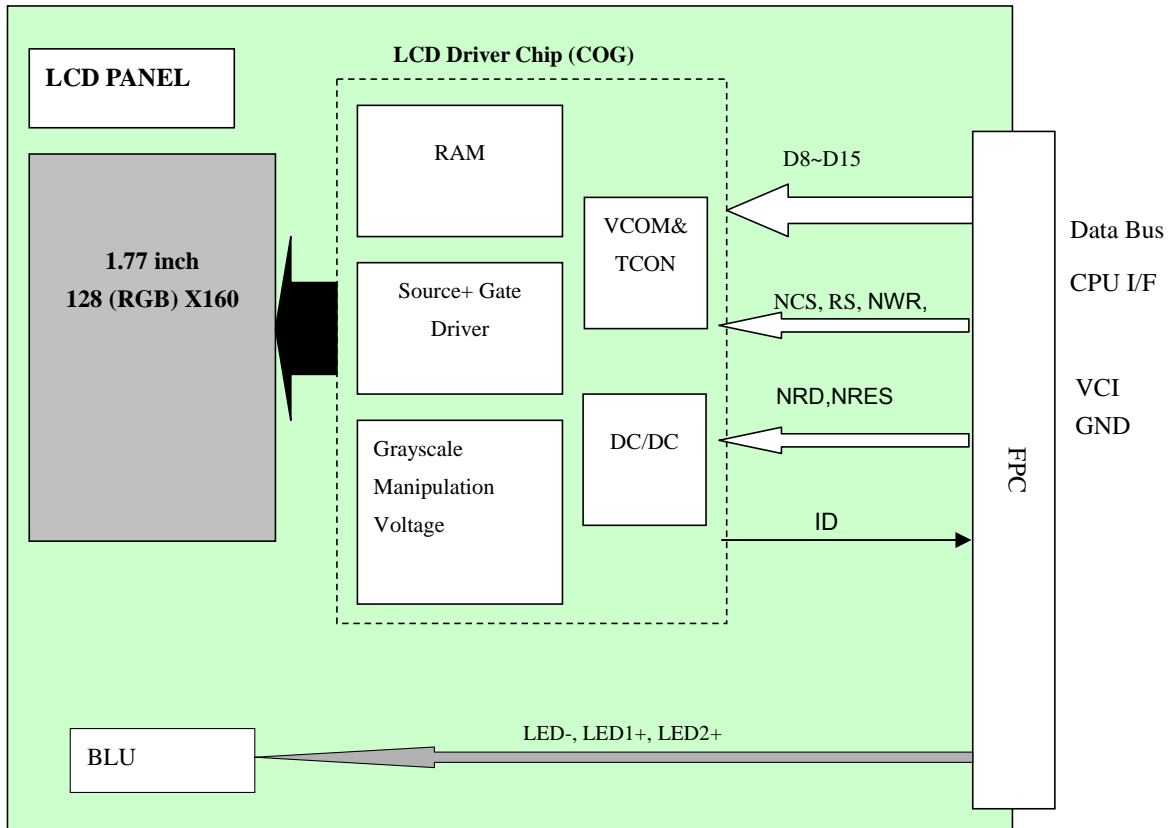



5 Timing Chart

5.1 Timing Parameter

Signal	Symbol	Parameter	Min.	Max.	Unit	Description
RS	t _{AST}	Address setup time	0	-	ns	-
	t _{AHT}	Address hold time (Write/Read)	10	-	ns	-
NCS	t _{CHW}	Chip select "H" pulse width	0	-	-	-
	t _{CS}	Chip select setup time (Write)	15	-	ns	-
	t _{RC}	Chip select setup time (Read ID)	45	-	ns	-
	t _{RCFSM}	Chip select setup time (Read FM)	355	-	ns	-
	t _{CSF}	Chip select wait time (Write/Read)	10	-	ns	-
NWR	t _{WC}	Write cycle	66	-	ns	-
	t _{WRH}	Control pulse "H" duration	15	-	ns	-
	t _{WRL}	Control pulse "L" duration	15	-	ns	-
NRD	t _{RC}	Read cycle (ID)	160	-	ns	When read ID data
	t _{RDH}	Control pulse "H" duration (ID)	90	-	ns	-
	t _{RD_L}	Control pulse "L" duration (ID)	45	-	ns	-
NRD_E (FM)	t _{RCFM}	Read cycle (FM)	450	-	ns	When read from frame memory
	t _{RD_HFM}	Control pulse "H" duration (FM)	90	-	ns	-
	t _{RD_LFM}	Control pulse "L" duration (FM)	355	-	ns	-
DB15 to DB8	t _{DST}	Data setup time	10	-	ns	For maximum C _L =30pF For minimum C _L =8pF
	t _{DHT}	Data hold time	10	-	ns	
	t _{RAT}	Read access time (ID)	-	40	ns	
	t _{RATFM}	Read access time (FM)	-	340	ns	
	t _{ODH}	Output disable time	20	80	ns	

Table 5.1 timing parameter

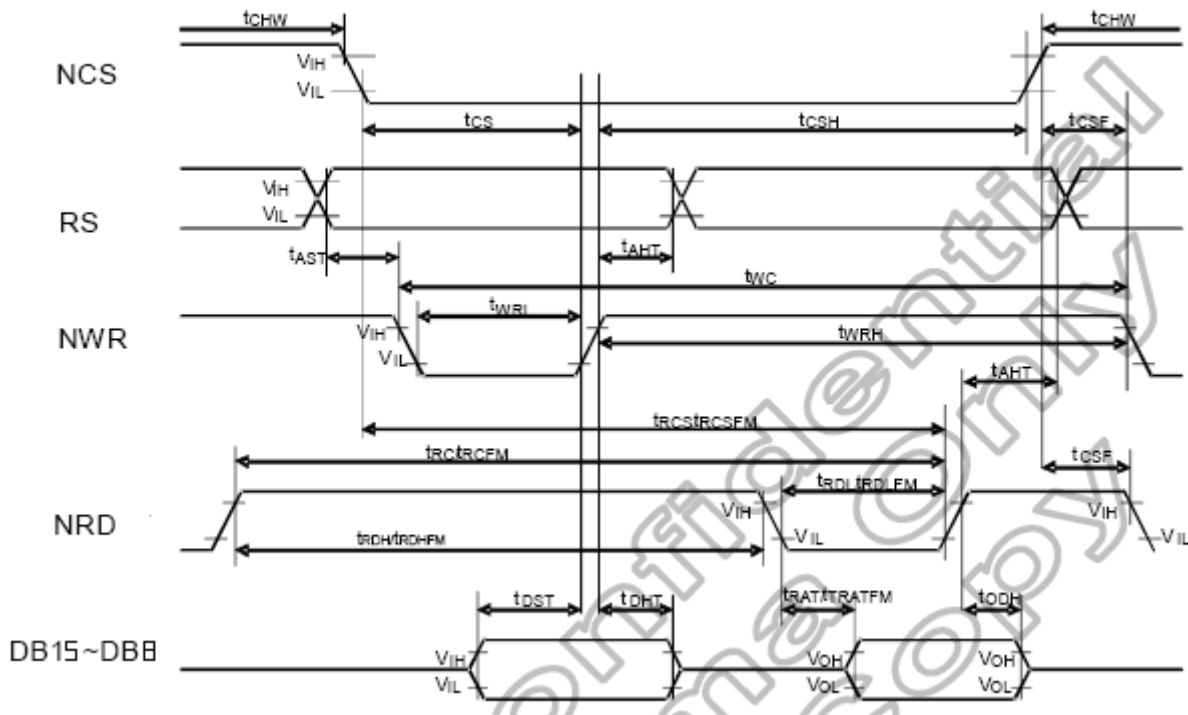
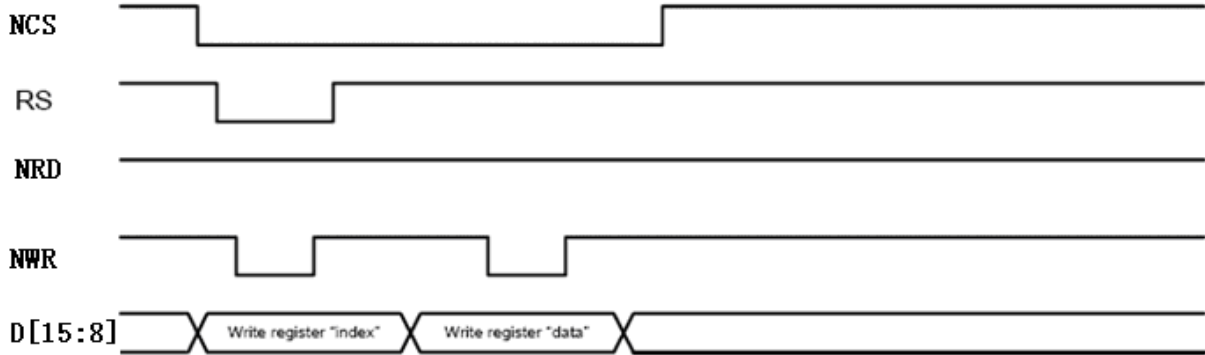

Figure 5.1 i80 System Bus Timing



5.2 Register write/read timing in I80 series system

a, Write to register



b. Read from register

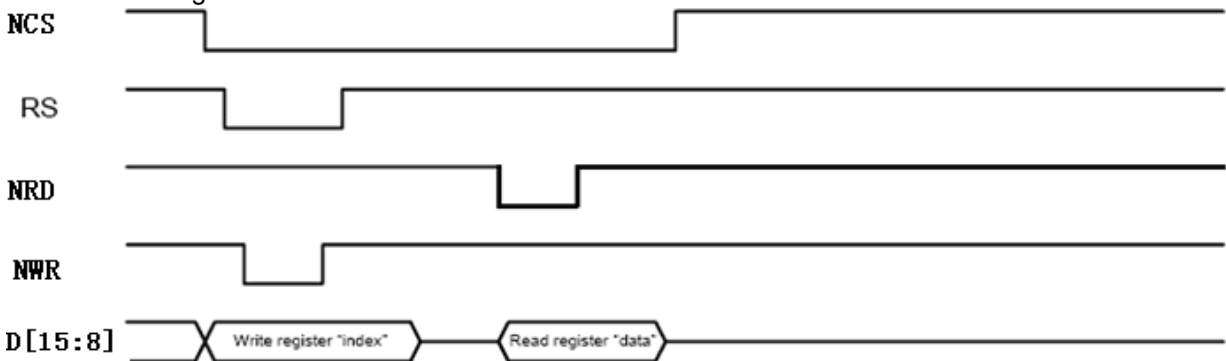

5.3 GRAM write timing in i80 series system

65k Color Data	DNC/RS	DB7	DB6	DB5	DB4	DB3	DB2	DB1	DB0	GRAM Write
MEMWR	0	GRAM Write command code								-
1st write	1	R14	R13	R12	R11	R10	G15	G14	G13	-
2nd write	1	G12	G11	G10	B14	B13	B12	B11	B10	1st pixel (R1/G1/B1)
3rd write	1	R24	R23	R22	R21	R20	G25	G24	G23	-
4th write	1	G22	G21	G20	B24	B23	B22	B21	B20	2nd pixel (R2/G2/B2)

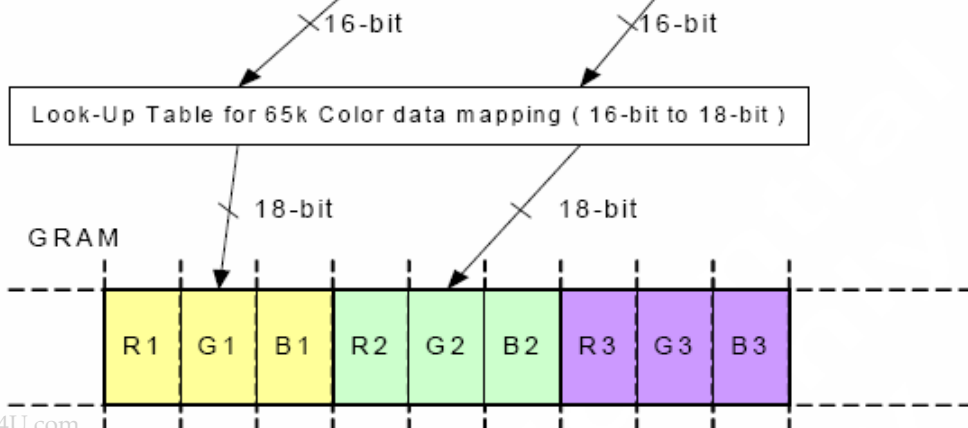

www.DataSheet4U.com

Table 5.3 GRAM Data and display data of 8-bit(65K Color) system interface

The information contained herein is the exclusive property of SHANGHAI TIANMA MICRO-ELECTRONICS Corporation, and shall not be distributed, reproduced, or disclosed in whole or in part without prior written permission of SHANGHAI TIANMA MICRO-ELECTRONICS Corporation.



GRAM Read/Write Timing

Write to GRAM

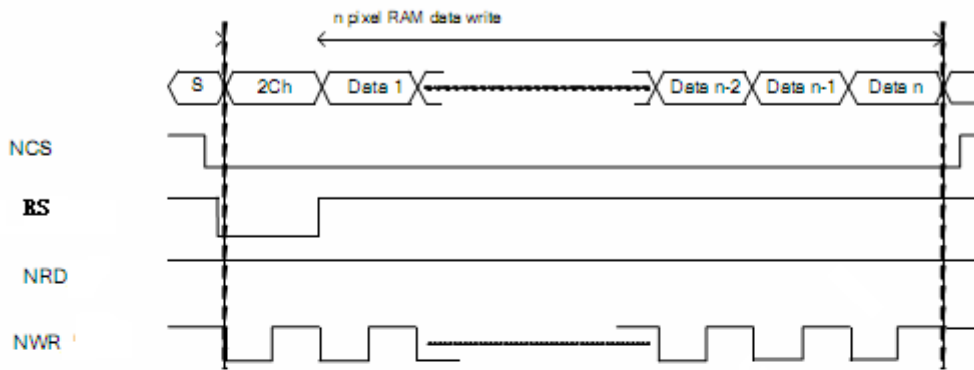

Read from GRAM

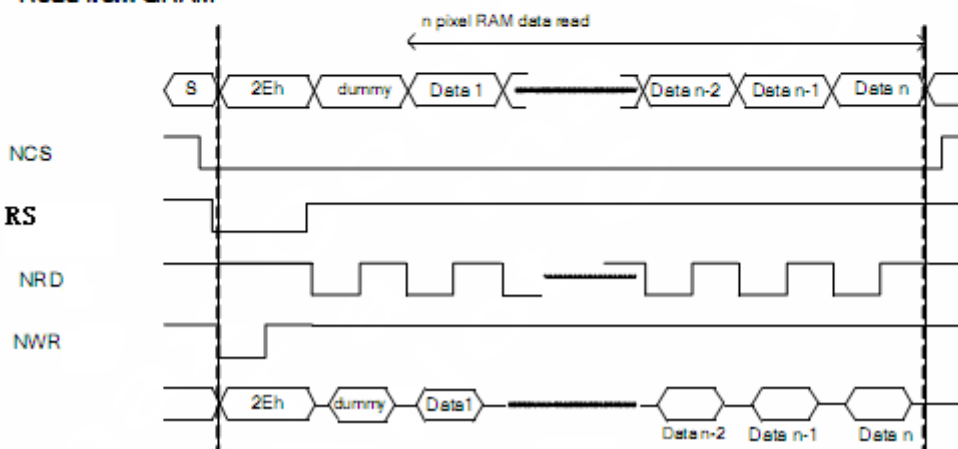

5.4 Reset Timing Characteristics

Ta=25°C

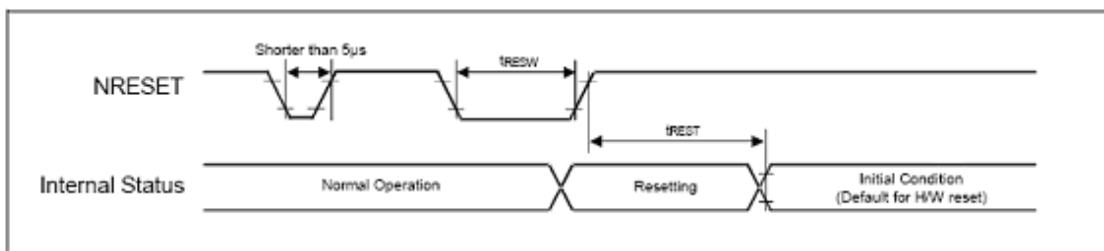

Reset Input Timing

Symbol	Parameter	Related Pins	Spec.			Note	Unit
			Min.	Typ.	Max.		
tRESW	Reset low pulse width ⁽¹⁾	NRESET	10	-	-	-	µs
tREST	Reset complete time ⁽²⁾	-	-	-	5	When reset applied during Sleep In mode	ms
		-	-	-	120	When reset applied during Sleep Out mode	ms

Figure 5.4 NRES Timing



5.5 Power On/Off sequence
5.5.1 Power on Sequence

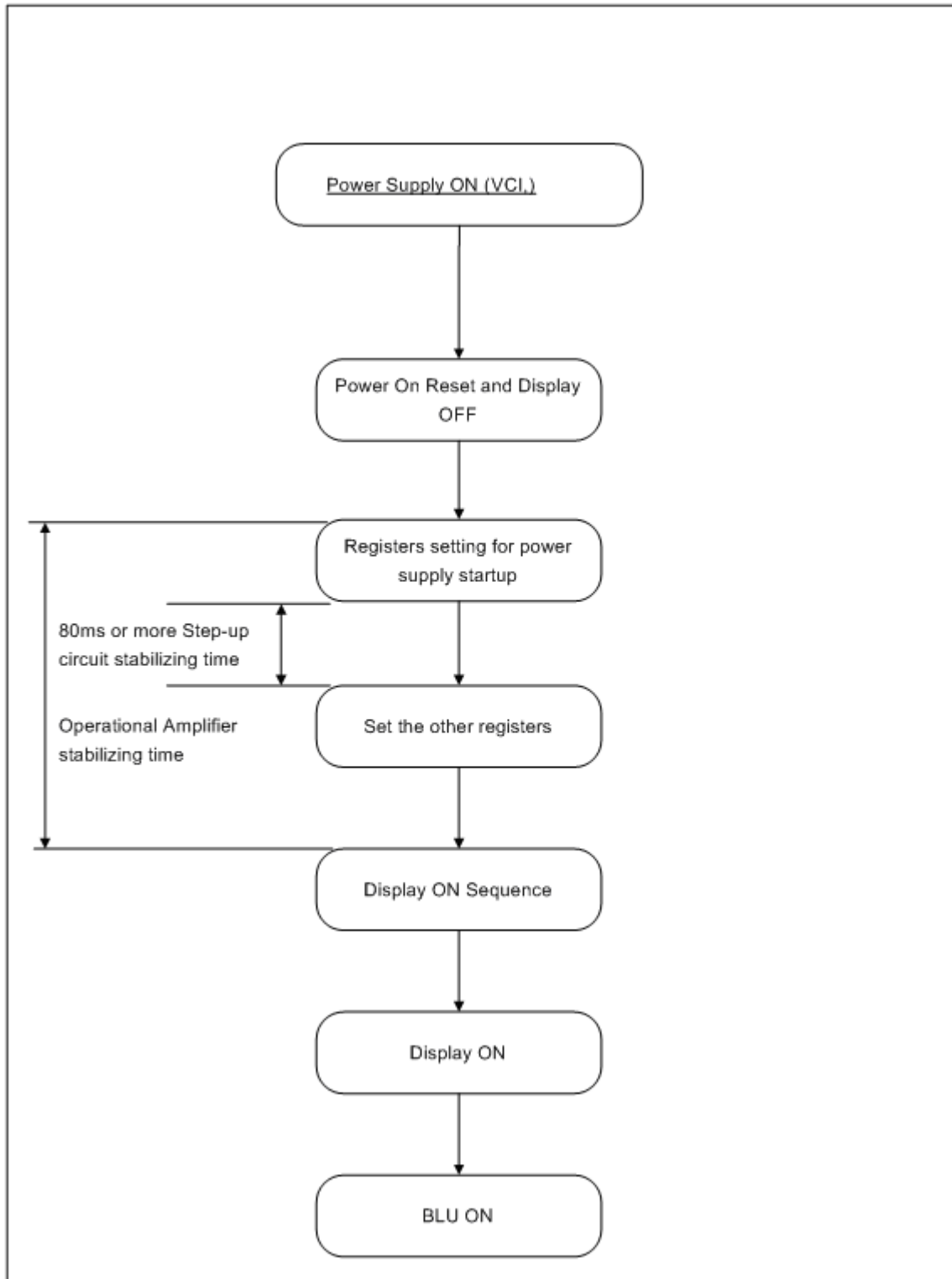



5.5.2 Power off Sequence

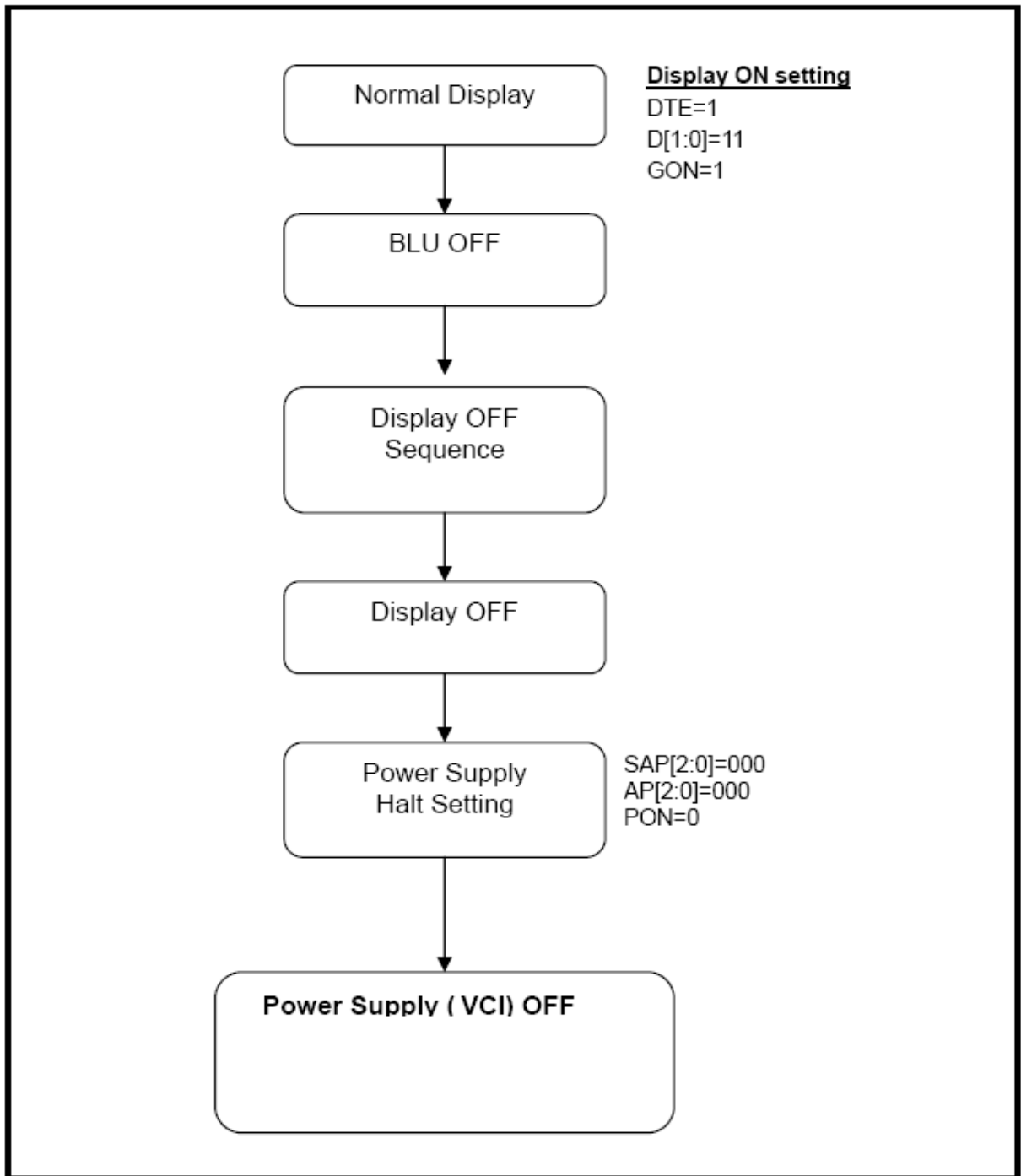



6 Optical Characteristics

Ta=25°C

Item	Symbol	Condition	Min	Typ	Max	Unit	Remark	
View Angles	θT	$CR \geq 10$	45	50	-	Degree	Note 2	
	θB		15	20	-			
	θL		40	45	-			
	θR		40	45	-			
Contrast Ratio	CR	$\theta=0^\circ$	200	350	-	-	Note1 Note3	
Response Time	T_{ON}	25°C	-	30	40	ms	Note1	
	T_{OFF}						Note4	
Chromaticity	White	Backlight is on	x	0.238	0.288	0.338	-	Note5 Note1
			y	0.258	0.308	0.358		
	Red		x	0.554	0.604	0.654		
			y	0.295	0.345	0.395		
	Green		x	0.284	0.334	0.384		
			y	0.450	0.500	0.550		
	Blue		x	0.095	0.144	0.194		
			y	0.061	0.111	0.161		
Uniformity	U	-	70	80	-	%	Note1 Note6	
NTSC	-	-	-	40	-	%	Note 5	
Luminance	L		200	250	-	cd/m ²	Note1 Note7	

Test Conditions:

1. $V_F=3.2V$, $I_F=15mA$ (One LED current), the ambient temperature is 25°C.
2. The test systems refer to Note 1 and Note 2.



Note 1: Definition of optical measurement system.

The optical characteristics should be measured in dark room. After 5 minutes operation, the optical properties are measured at the center point of the LCD screen. All input terminals LCD panel must be ground when measuring the center area of the panel.

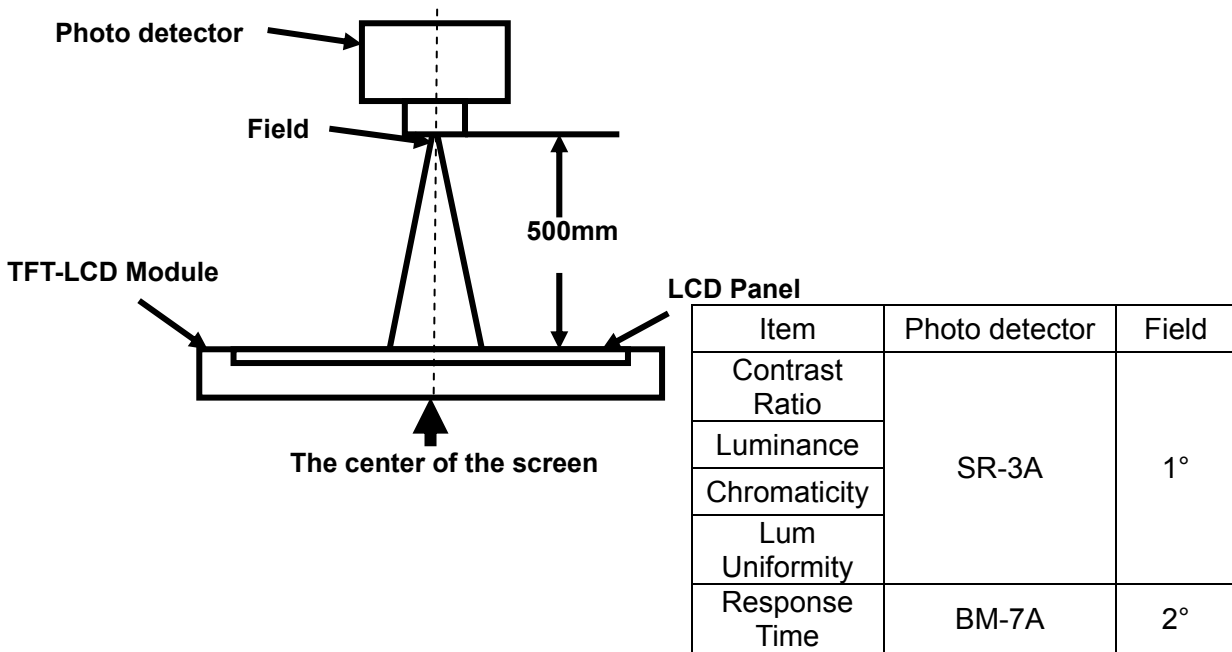

Note 2: Definition of viewing angle range and measurement system.

viewing angle is measured at the center point of the LCD by CONOSCOPE(ergo-80).

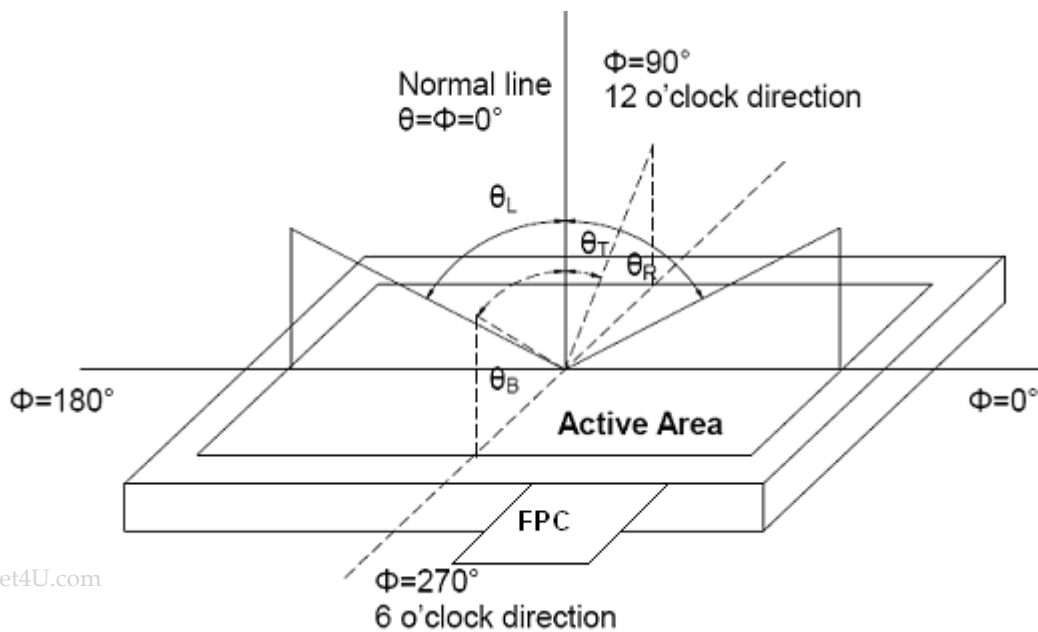

Fig. 1 Definition of viewing angle

**Note 3: Definition of contrast ratio**

$$\text{Contrast ratio (CR)} = \frac{\text{Luminance measured when LCD is on the "White" state}}{\text{Luminance measured when LCD is on the "Black" state}}$$

“White state “:The state is that the LCD should driven by Vwhite.

“Black state”: The state is that the LCD should driven by Vblack.

Vwhite: To be determined Vblack: To be determined.

Note 4: Definition of Response time

The response time is defined as the LCD optical switching time interval between “White” state and “Black” state. Rise time (TON) is the time between photo detector output intensity changed from 90% to 10%. And fall time (TOFF) is the time between photo detector output intensity changed from 10% to 90%.

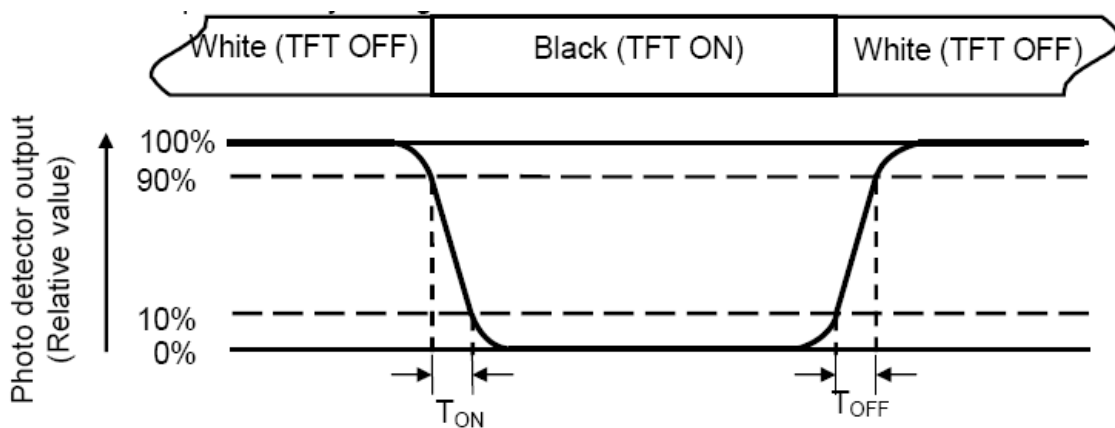
**Note 5: Definition of color chromaticity (CIE1931)**

Color coordinates measured at center point of LCD.

**Note 6: Definition of Luminance Uniformity**

Active area is divided into 9 measuring areas (Refer Fig. 2). Every measuring point is placed at the center of each measuring area.

$$\text{Luminance Uniformity}(U) = L_{\min} / L_{\max}$$

L-----Active area length W----- Active area width

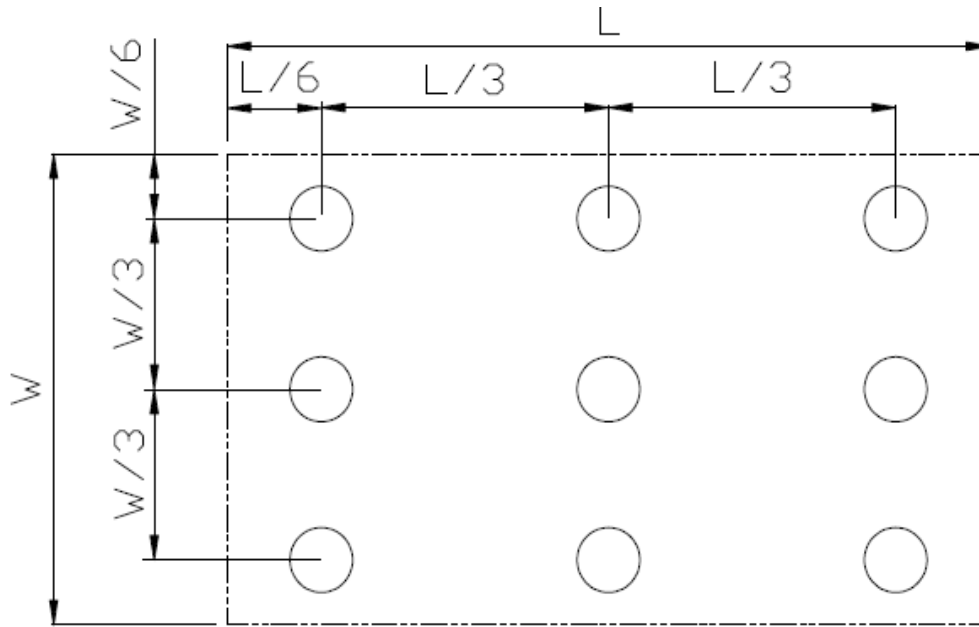

Fig. 2 Definition of uniformity

L_{\max} : The measured maximum luminance of all measurement position.

L_{\min} : The measured minimum luminance of all measurement position.

Note 7: Definition of Luminance :

Measure the luminance of white state at center point.



7 Environmental / Reliability Test

No	Test Item	Condition	Remark
1	High Temperature Operation	T _s =+70°C, 240hrs	Note1 IEC60068-2-2,GB2423.2—89
2	Low Temperature Operation	T _a =-20°C, 240hrs	IEC60068-2-1 GB2423.1—89
3	High Temperature Storage	T _a =+80°C, 240hrs	IEC60068-2-2, GB2423.2—89
4	Low Temperature Storage	T _a =-30°C, 240hrs	IEC60068-2-1 GB2423.1—89
5	High Temperature & High Humidity Storage	T _a =+60°C, 90% RH 240 hours	Note2 IEC60068-2-3, GB/T2423.3—2006
6	Thermal Shock (Non-operation)	-30°C 30 min~+70°C 30 min, Change time:5min, 20 Cycles	Start with cold temperature, End with high temperature, IEC60068-2-14,GB2423.22—87
7	Electro Static Discharge (Operation)	C=150pF, R=330Ω,5points/panel Air:± 8KV, 5times, Contact:± 4KV, 5 times, (Environment: 15°C ~ 35°C, 30% ~ 60%, 86Kpa ~ 106Kpa)	IEC61000-4-2 GB/T17626.2—1998
8	Vibration (Non-operation)	Frequency range:10~55Hz, Stroke:1.5mm Sweep:10Hz~55Hz~10Hz 2 hours for each direction of X.Y.Z. (6 hours for total)(Package condition)	IEC60068-2-6 GB/T2423.10—1995
9	Shock (Non-operation)	60G 6ms, ± X,± Y,± Z 3times, for each direction	IEC60068-2-27 GB/T2423.5—1995
10	Package Drop Test	Height:80 cm, 1 corner, 3 edges, 6 surfaces	IEC60068-2-32 GB/T2423.8—1995

Note1: T_s is the temperature of panel's surface.

Note2: T_a is the ambient temperature of sample.



9 Packing Drawing

No	Item	Model (Material)	Dimensions(mm)	Unit Weight(Kg)	Quantity	Remark	
1	LCM module	TM017FDH02	34x47x2.4	0.0062	1056		
2	Tray	PET(Transmit)	315×247×10.8	0.0845	54	Anti-static	
3	EPE	EPE	315×247×5	0.009	12		
4	Anti-static bag	PE	327×440	0.021	6		
5	BOX	Corrugated Paper	345×260×70	0.227	6		
6	Desiccant	Desiccant	45x50	0.0035	12		
7	Carton	Corrugated Paper	544×365×250	1.01	1		
8	Total weight(Kg)	13.75					

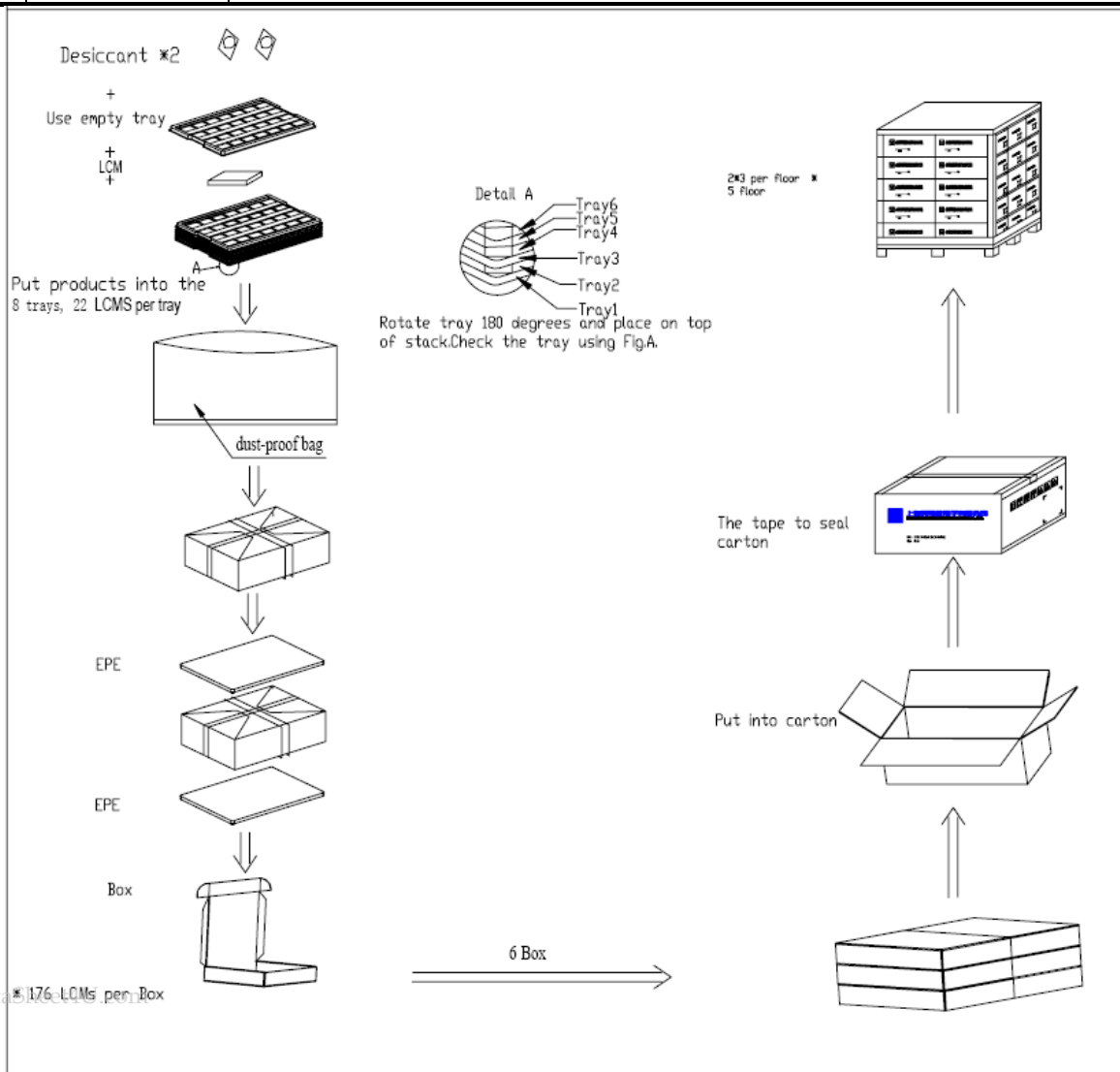

www.DataSheet4U.com 176 LCMs per Box

The information contained herein is the exclusive property of SHANGHAI TIANMA MICRO-ELECTRONICS Corporation, and shall not be distributed, reproduced, or disclosed in whole or in part without prior written permission of SHANGHAI TIANMA MICRO-ELECTRONICS Corporation.



10 Precautions For Use of LCD Modules

10.1 Handling Precautions

- 10.1.1 The display panel is made of glass. Do not subject it to a mechanical shock by dropping it from a high place, etc.
- 10.1.2 If the display panel is damaged and the liquid crystal substance inside it leaks out, be sure not to get any in your mouth, if the substance comes into contact with your skin or clothes, promptly wash it off using soap and water.
- 10.1.3 Do not apply excessive force to the display surface or the adjoining areas since this may cause the color tone to vary.
- 10.1.4 The polarizer covering the display surface of the LCD module is soft and easily scratched. Handle this polarizer carefully.
- 10.1.5 If the display surface is contaminated, breathe on the surface and gently wipe it with a soft dry cloth. If still not completely clear, moisten cloth with one of the following solvents:

- Isopropyl alcohol
- Ethyl alcohol

Solvents other than those mentioned above may damage the polarizer. Especially, do not use the following:

- Water
- Ketone
- Aromatic solvents

- 10.1.6 Do not attempt to disassemble the LCD Module.
- 10.1.7 If the logic circuit power is off, do not apply the input signals.
- 10.1.8 To prevent destruction of the elements by static electricity, be careful to maintain an optimum work environment.
 - 10.1.8.1 Be sure to ground the body when handling the LCD Modules.
 - 10.1.8.2 Tools required for assembly, such as soldering irons, must be properly ground.
 - 10.1.8.3 To reduce the amount of static electricity generated, do not conduct assembly and other work under dry conditions.
 - 10.1.8.4 The LCD Module is coated with a film to protect the display surface. Be care when peeling off this protective film since static electricity may be generated.

10.2 Storage precautions

- 10.2.1 When storing the LCD modules, avoid exposure to direct sunlight or to the light of fluorescent lamps.
- 10.2.2 The LCD modules should be stored under the storage temperature range. If the LCD modules will be stored for a long time, the recommend condition is:
Temperature : 0°C ~ 40°C Relatively humidity: ≤80%
- 10.2.3 The LCD modules should be stored in the room without acid, alkali and harmful gas.

10.3 Transportation Precautions

The LCD modules should be no falling and violent shocking during transportation, and also should avoid excessive press, water, damp and sunshine.

The information contained herein is the exclusive property of SHANGHAI TIANMA MICRO-ELECTRONICS Corporation, and shall not be distributed, reproduced, or disclosed in whole or in part without prior written permission of SHANGHAI TIANMA MICRO-ELECTRONICS Corporation.