



MODEL NO. : TM023KDH42

ISSUED DATE: 2011-07-07

VERSION : Ver 2.0

- Preliminary Specification  
 Final Product Specification

Customer : \_\_\_\_\_

Approved by	Notes

SHANGHAI TIANMA Confirmed :

Prepared by	Checked by	Approved by

This technical specification is subjected to change without notice



MODEL NO. : TM023KDH42

ISSUED DATE: 2011-07-07

VERSION : Ver 2.0

- Preliminary Specification
- Final Product Specification

Customer : \_\_\_\_\_

Approved by	Notes

SHANGHAI TIANMA Confirmed :

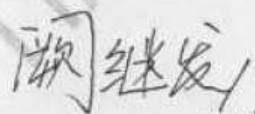
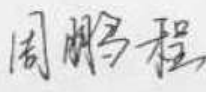
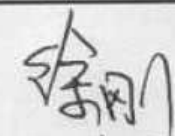
Prepared by	Checked by	Approved by
 2011.7.8	 2011.7.8	 2011-7-8

This technical specification is subjected to change without notice



## Table of Contents

Coversheet .....	1
Table of Contents .....	3
Record of Revision.....	4
1 General Specifications.....	5
2 Input/Output Terminals .....	6
3 Absolute Maximum Ratings.....	8
4 Electrical Characteristics .....	8
5 Timing Chart.....	11
6 Optical Characteristics .....	18
7 Environmental / Reliability Test.....	22
8 Mechanical Drawing .....	23
9 Packing Drawing .....	24
10 Precautions For Use of LCD Modules.....	26

TIANMA CONFIDENTIAL



### Record of Revision

Rev	Issued Date	Description	Editor
1.0	2011-6-16	Preliminary Specification Release	Que jifa
2.0	2011-7-7	Final Specification	Que jifa



## 1 General Specifications

Feature		Spec
<b>Display Spec.</b>	Size	2.3 inch
	Resolution	320(RGB) x 240
	Interface	CPU 8/16bit
	Color Depth	65/262K
	Technology Type	a-Si
	Pixel Pitch (mm)	0.1461x0.1461
	Pixel Configuration	R.G.B. Vertical Stripe
	Display Mode	TM with Normally White
	Surface Treatment(Up Polarizer)	Clear Type(3H)
	Viewing Direction	6 o'clock
	Gray Scale Inversion Direction	12 o'clock
<b>Mechanical Characteristics</b>	LCM (W x H x D) (mm)	34.0x47.0x2.4
	Active Area(mm)	46.752x35.064
	With/Without TSP	Without TSP
	Weight (g)	10.8
	LED Numbers	4 LEDs
<b>Electronic</b>	Driver IC	ILI 9342

Note 1: Viewing direction for best image quality is different from TFT definition, there is a 180 degree shift.

Note 2 : Requirements on Environmental Protection: Q/S0002

Note 3 : LCM weight tolerance : +/- 5%



## 2 Input/Output Terminals

### 2.1 TFT LCD Panel

No	Symbol	I/O	Description	Remarks
1	LEDA	I	LED Anode	
2	LEDK1	I	LED Cathode	
3	LEDK2	I	LED Cathode	
4	LEDK3	I	LED Cathode	
5	LEDK4	I	LED Cathode	
6	GND	P	Power Ground	
7	RESET	I	A reset signal	
8	DB15	I/O	Data input fix to GND level when not in use	
9	DB14	I/O	Data input fix to GND level when not in use	
10	DB13	I/O	Data input fix to GND level when not in use	
11	DB12	I/O	Data input fix to GND level when not in use	
12	DB11	I/O	Data input fix to GND level when not in use	
13	DB10	I/O	Data input fix to GND level when not in use	
14	DB9	I/O	Data input fix to GND level when not in use	
15	DB8	I/O	Data input fix to GND level when not in use	
16	DB7	I/O	Data input fix to GND level when not in use	
17	DB6	I/O	Data input fix to GND level when not in use	
18	DB5	I/O	Data input fix to GND level when not in use	
19	DB4	I/O	Data input fix to GND level when not in use	
20	DB3	I/O	Data input fix to GND level when not in use	
21	DB2	I/O	Data input fix to GND level when not in use	
22	DB1	I/O	Data input fix to GND level when not in use	
23	DB0	I/O	Data input fix to GND level when not in use	
24	W16_8X	I	CPU interface select pin W16_8X=1, 16bit, DB0-DB15 is used; W16_8X=0, 8bit, DB0-DB7 is used.	
25	RD	I	A read strobe signal and enables an operation to read out data when the signal is low.	
26	WR	I	A write strobe signal and enables an operation to write data when the signal is low.	



27	RS	I	A register select signal	
28	CS	I	A chip select signal	
29	IOVCC	P	I/O pad and digital power supply	
30	VCC	P	Analog power supply	
31	VCI	P	Analog power supply	
32	GND	P	Power Ground	
33	FMARK	O	Tearing effect output pin, if not used, let it open	
34	NC	---	No connection	
35	NC	---	No connection	
36	NC	---	No connection	

Note2-1: I/O definition:

I----Input O---Output P----Power/Ground



### 3 Absolute Maximum Ratings

#### 3.1 Driving TFT LCD Panel

GND=0V, Ta = 25°C

Item	Symbol	Min	Max	Unit	Remark
Logic Supply Voltage	IOVCC	-0.3	3.3	V	
Analog Supply Voltage	VCI/VCC	-0.3	4.8	V	
Input Voltage	D7~D0,/CS,RS,/WS, RD /LCD_RESET	-0.3	VCI+0.3	V	
Back Light Forward Current	I <sub>LED</sub>		25	mA	For each LED
Operating Temperature	T <sub>OPR</sub>	-20	70	°C	
Storage Temperature	T <sub>STG</sub>	-30	80	°C	

### 4 Electrical Characteristics

#### 4.1 Driving TFT LCD Panel

GND=0V, Ta=25°C

Item	Symbol	Min	Typ	Max	Unit	Remark
Logic Supply Voltage	IOVCC	1.65	1.8/2.8	3.3	V	
Analog Supply Voltage	VCI/VCC	2.3	2.8	4.8	V	
Input Signal Voltage	Low Level V <sub>IL</sub>	-0.3	--	0.2xIOVCC	V	D7~D0,/CS,RS,/WS, RD /LCD_RESET
	High Level V <sub>IH</sub>	0.8xIOVCC	--	IOVCC	V	
Output Signal Voltage	Low Level V <sub>OL</sub>	--	--	0.2xIOVCC	V	
	High Level V <sub>OH</sub>	0.8xIOVCC	--	IOVCC	V	
(Panel+ LSI) Power Consumption	Black Mode (60Hz)	--	13.57	--	mW	
	Sleeping Mode	--	0.03	--	mW	





## 4.2 Driving Backlight

Ta=25°C

Item	Symbol	Min	Typ	Max	Unit	Remark
Forward Current	$I_F$	--	15	25	mA	
Forward Current Voltage	$V_F$	--	3.2	--	V	
Backlight Power Consumption	$W_{BL}$	--	192	--	mW	Four LEDs
Operating Life Time	--	10000	(20000)	--	Hrs	

Note 1: The figure below shows the connection of backlight LED.

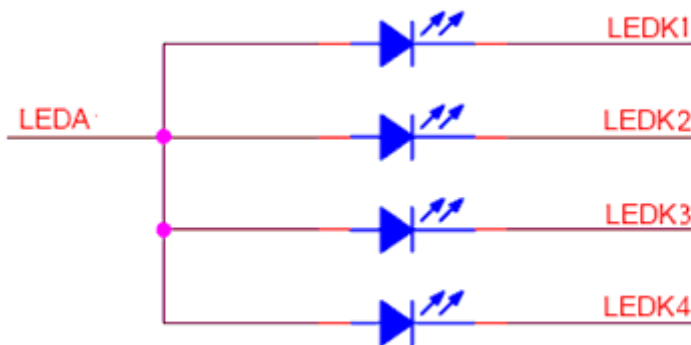

Note 2: One LED :  $I_F = 15 \text{ mA}$ ,  $V_F = 3.2 \text{ V}$

Note 3:  $I_F$  is defined for one channel LED.

Optical performance should be evaluated at  $T_a = 25^\circ \text{C}$  only.

If LED is driven by high current, high ambient temperature & humidity condition. The life time of LED will be reduced.

Operating life means brightness goes down to 50% initial brightness. Typical operating life time is estimated data.



### 4.3 Block Diagram

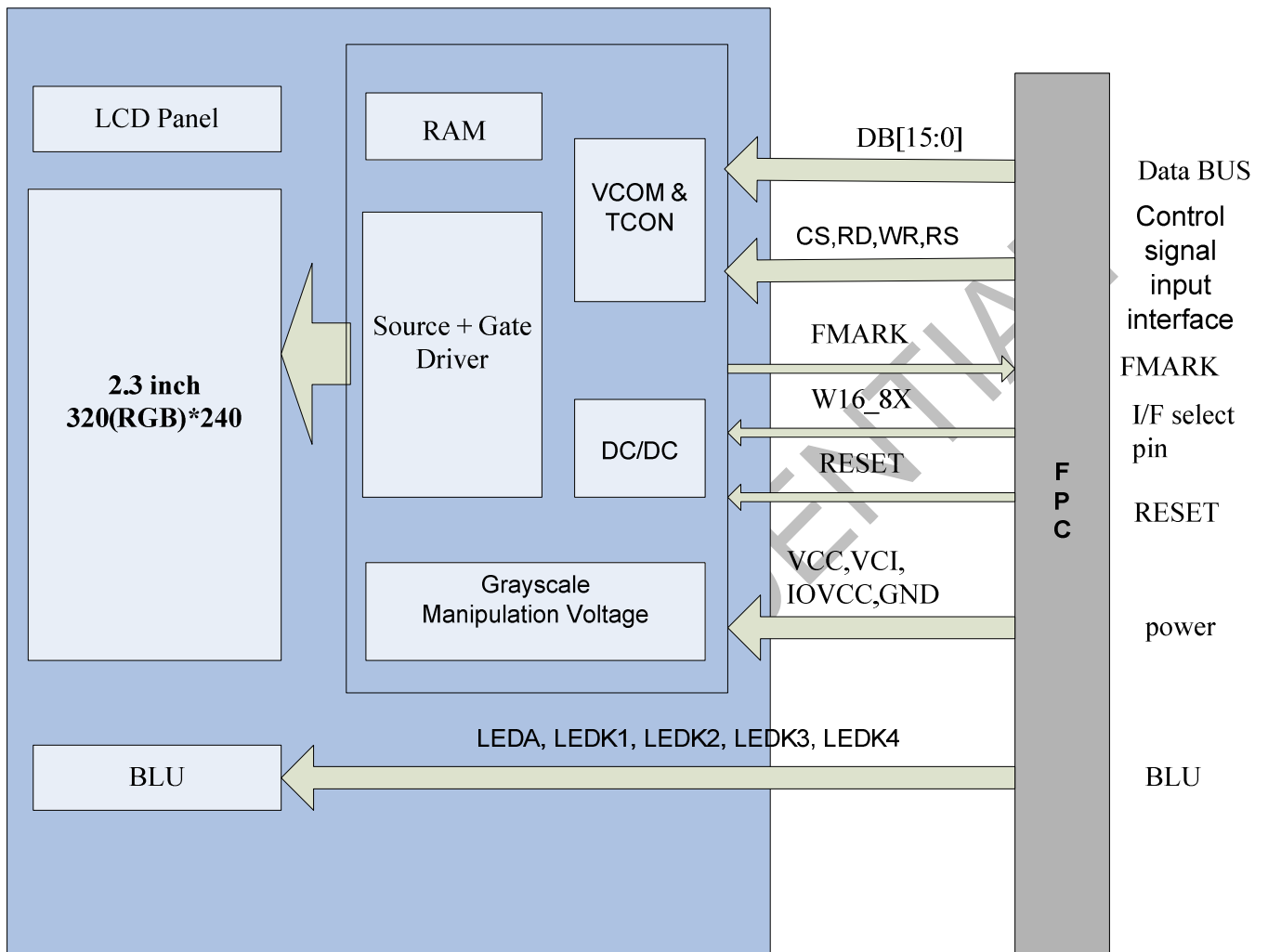



## 5 Timing Chart

### 5.1 Interface Characteristics

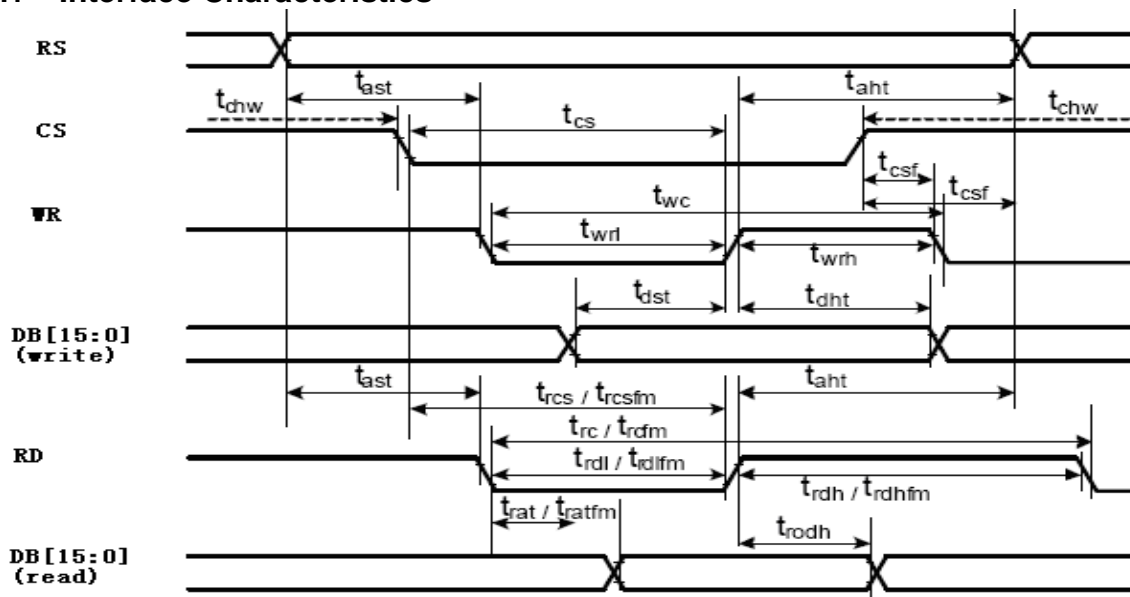

Figure 5.1 Interface Characteristics

### 5.2 Interface Timing Parameters

#### Normal Write Mode

Signal	Symbol	Parameter	Spec.			Description
			Min.	Max.	Unit	
RS	$t_{AST}$	Address setup time	0	-	ns	-
	$t_{AHT}$	Address hold time(Write/Read)	10	-	ns	-
CS	$t_{CHW}$	Chip select "H" pulse width	0	-	-	-
	$t_{CS}$	Chip select setup time (Write)	15	-	ns	-
	$t_{RCS}$	Chip select setup time (Read ID)	45	-	ns	-
	$t_{RCSFM}$	Chip select setup time (Read FM)	355	-	ns	-
	$t_{CSF}$	Chip select wait time(Write/Read)	10	-	ns	-
WR	$t_{WC}$	Write cycle	66	-	ns	-
	$t_{WRH}$	Control pulse "H" duration	33	-	ns	-
	$t_{WRL}$	Control pulse "L" duration	33	-	ns	-
RD (ID)	$t_{RC}$	Read cycle (ID)	160	-	ns	When read ID data
	$t_{RDH}$	Control pulse "H" duration (ID)	90	-	ns	
	$t_{RDL}$	Control pulse "L" duration (ID)	45	-	ns	
RD(FM)	$t_{RCFM}$	Read cycle (FM)	450	-	ns	When read from frame memory
	$t_{RDHFM}$	Control pulse "H" duration (FM)	90	-	ns	
	$t_{RDLFM}$	Control pulse "L" duration (FM)	355	-	ns	
DB[15:0],	$t_{DST}$	Data setup time	10	-	ns	For maximum $C_L=30pF$ For minimum $C_L=8pF$
	$t_{DHT}$	Data hold time	10	-	ns	
	$t_{RAT}$	Read access time (ID)	-	40	ns	
	$t_{RATFM}$	Read access time (FM)	-	340	ns	
	$T_{ROD}$	Output disable time	20	80	ns	

Table 5.2 CPU Interface Timing Parameters

The information contained herein is the exclusive property of SHANGHAI TIANMA MICRO-ELECTRONICS Corporation, and shall not be distributed, reproduced, or disclosed in whole or in part without prior written permission of SHANGHAI TIANMA MICRO-ELECTRONICS Corporation.



### 5.3 Interface Register write/read timing

#### 5.3.1 System Bus Interface Register or GRAM Write Timing

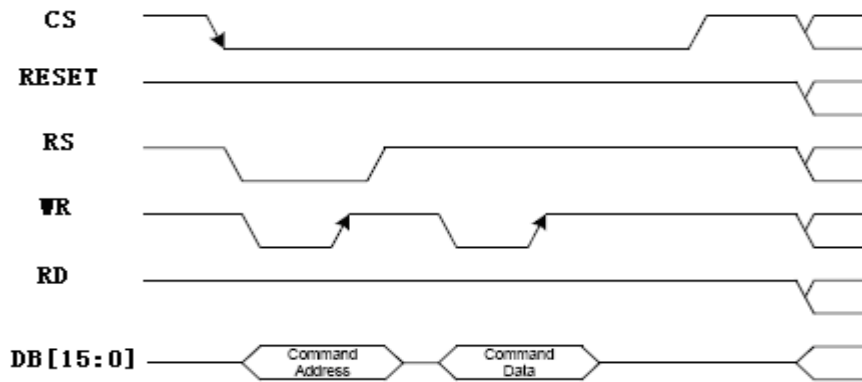

Figure 5.3.1 System Bus Interface Register or GRAM Write Timing

#### 5.3.2 System Bus Interface Register or GRAM Read Timing

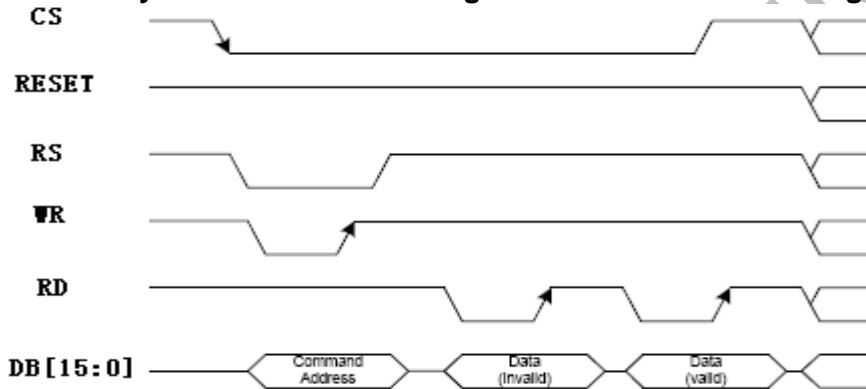

Figure 5.3.2 System Bus Interface Register or GRAM Read Timing

### 5.4 GRAM Write/Read Data Format

#### 5.4.1 Write data for RGB 5-6-5 (65k colors) bits input in 8-bit parallel Interface

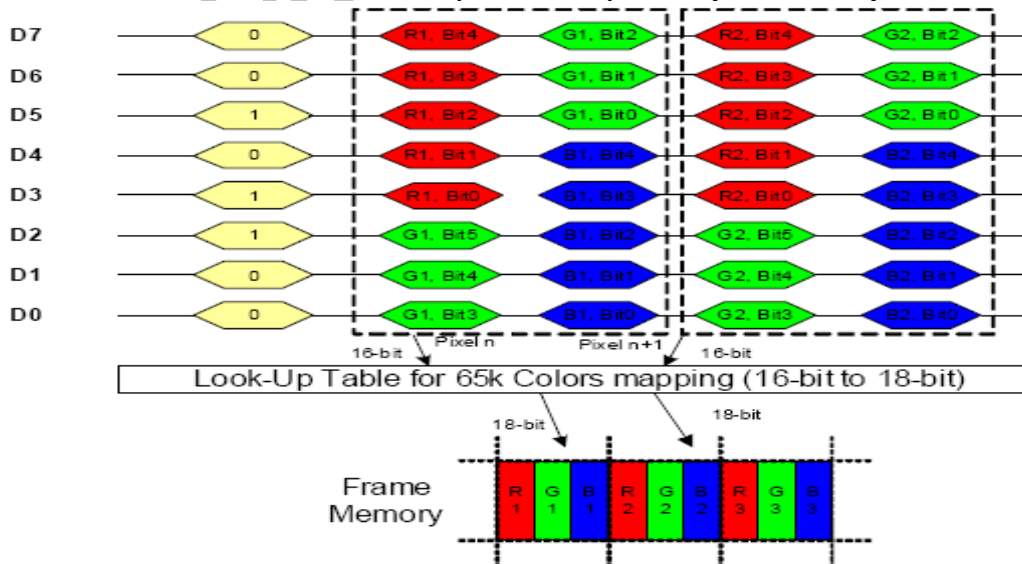

Figure 5.4.1 Write data for RGB 5-6-5 (65k colors) bits input in 8-bit parallel Interface



5.4.2 Write data for RGB 6-6-6 (262k colors) bits input in 8-bit parallel Interface

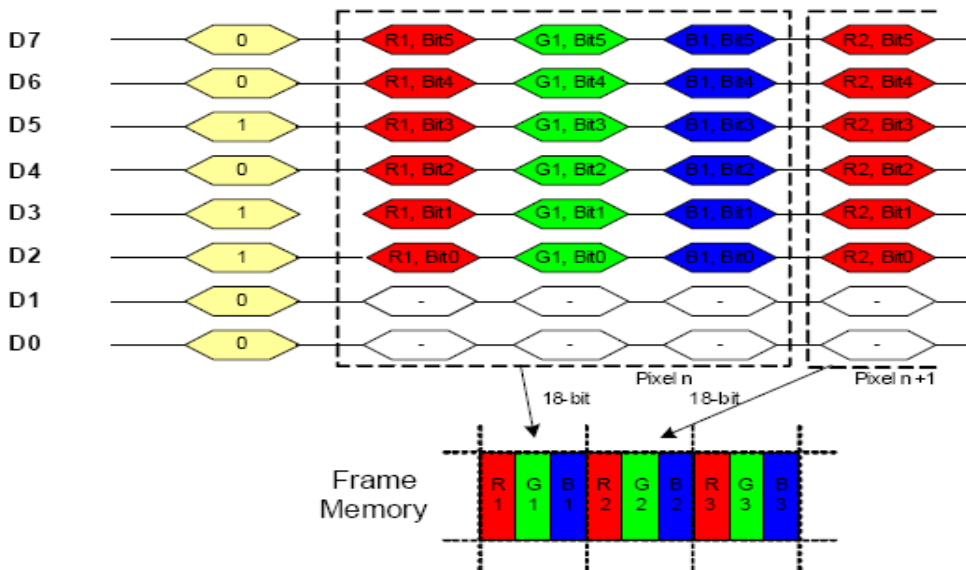

Figure 5.4.2 Write data for RGB 6-6-6 (262k colors) bits input in 8-bit parallel Interface

5.4.3 Write data for RGB 5-6-5 (65k colors) bits input in 16-bit parallel Interface

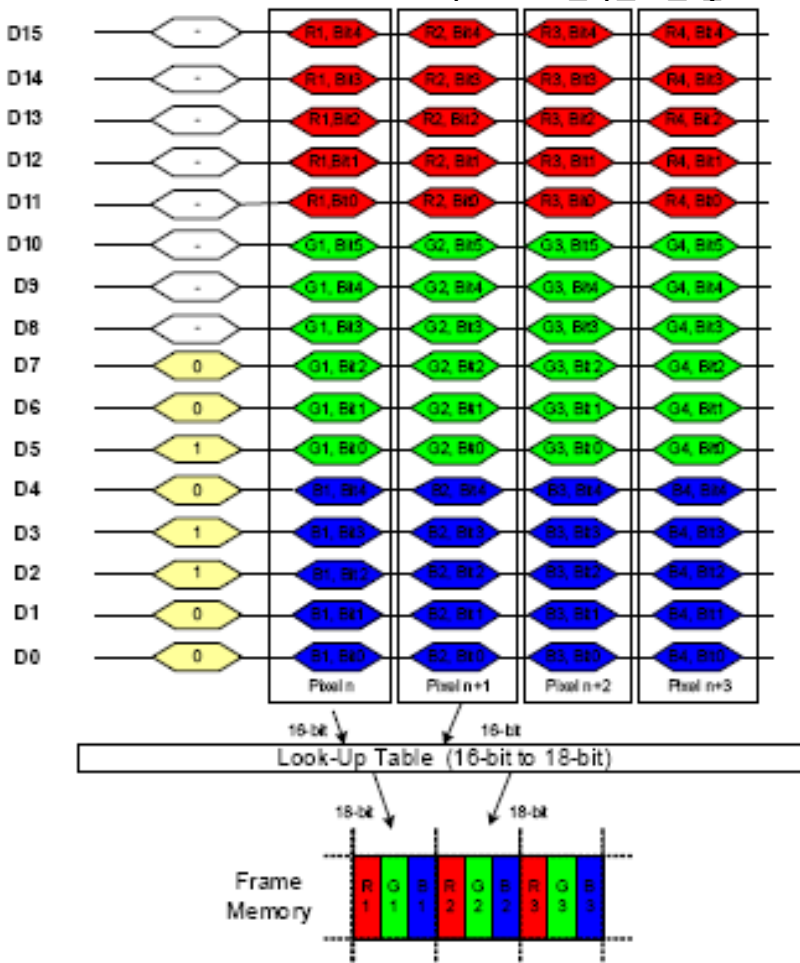

Figure 5.4.3 Write data for RGB 5-6-5 (65k colors) bits input in 16-bit parallel Interface



5.4.4 Write data for RGB 6-6-6 (262k colors) bits input in 16-bit parallel Interface

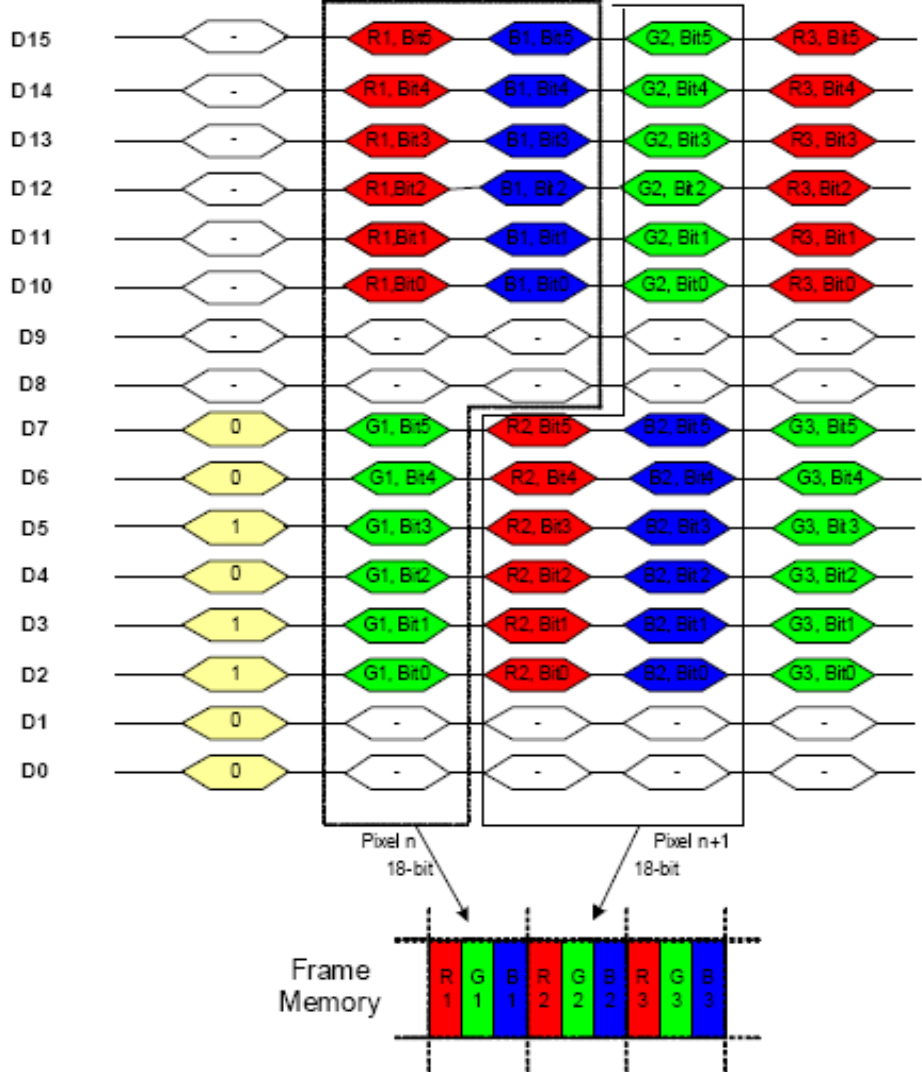

Figure 5.4.4 Write data for RGB 6-6-6 (262k colors) bits input in 16-bit parallel Interface

5.5 Reset Timing Characteristics

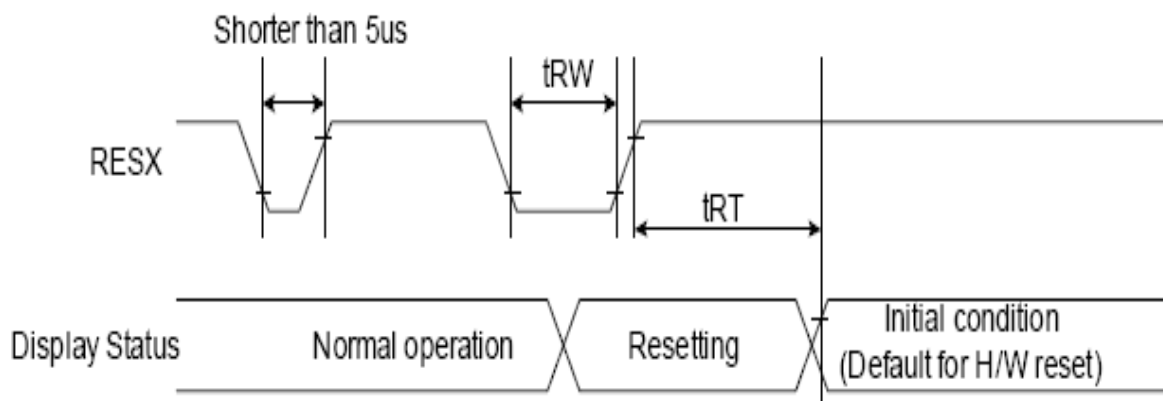

Figure 5.5.1 Reset Input Timing

The information contained herein is the exclusive property of SHANGHAI TIANMA MICRO-ELECTRONICS Corporation, and shall not be distributed, reproduced, or disclosed in whole or in part without prior written permission of SHANGHAI TIANMA MICRO-ELECTRONICS Corporation.



Symbol	Parameter	Related Pins	Spec.			Note	Unit
			Min.	Typ.	Max.		
$t_{RW}$	Reset low pulse duration	RESET	10	-	-	-	us
$t_{RT}$	Reset cancel	-	-	-	5	When reset applied during "Sleep In mode"	ms
		-	-	-	120	When reset applied during "Sleep Out mode"	ms

Table 5.5.1 Reset Timing Parameters

## Note:

RESET Pulse	Action
Shorter than 5 $\mu$ s	Reset Rejected
Longer than 10 $\mu$ s	Reset
Between 5 $\mu$ s and 10 $\mu$ s	Reset Start

## 5.6 Power On/Off sequence

## 5.6.1 Power on Sequence

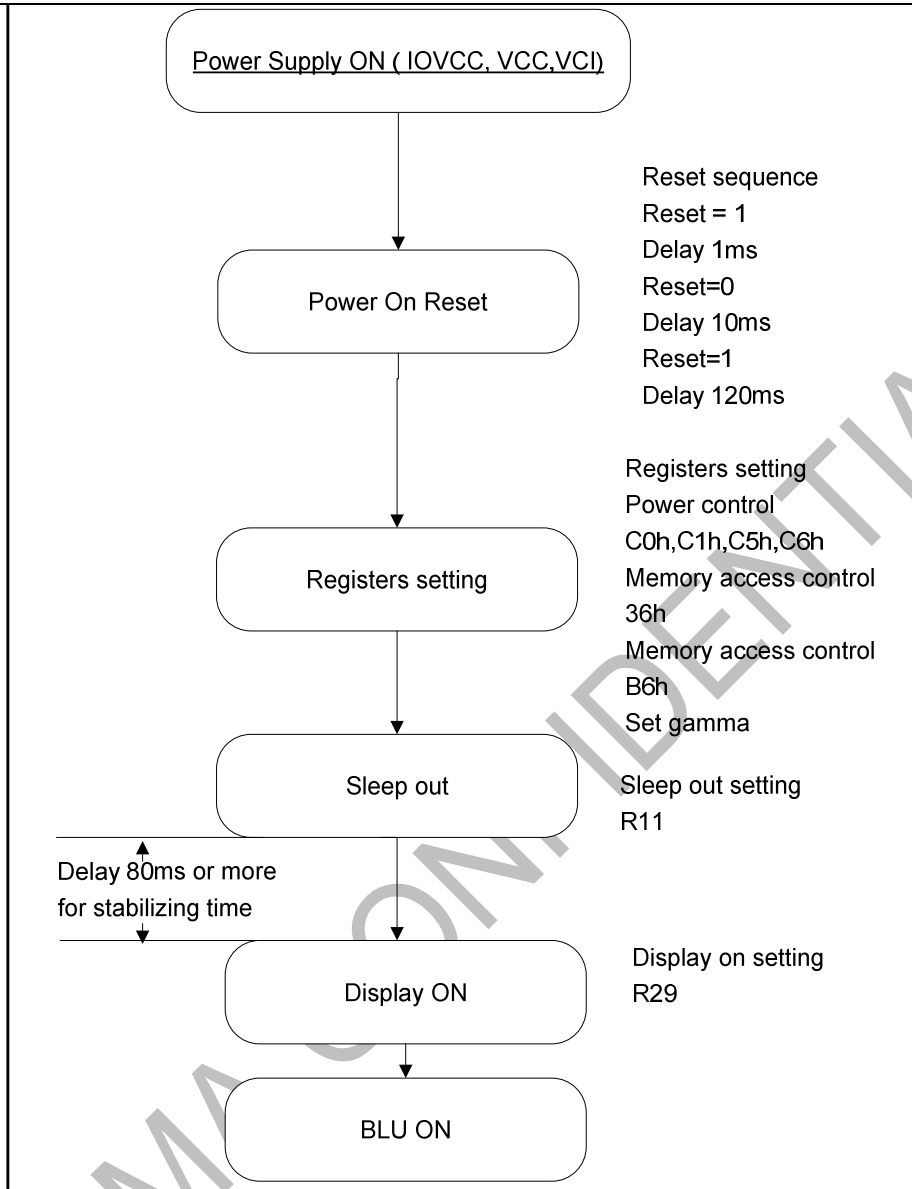





5.6.2 Power off Sequence

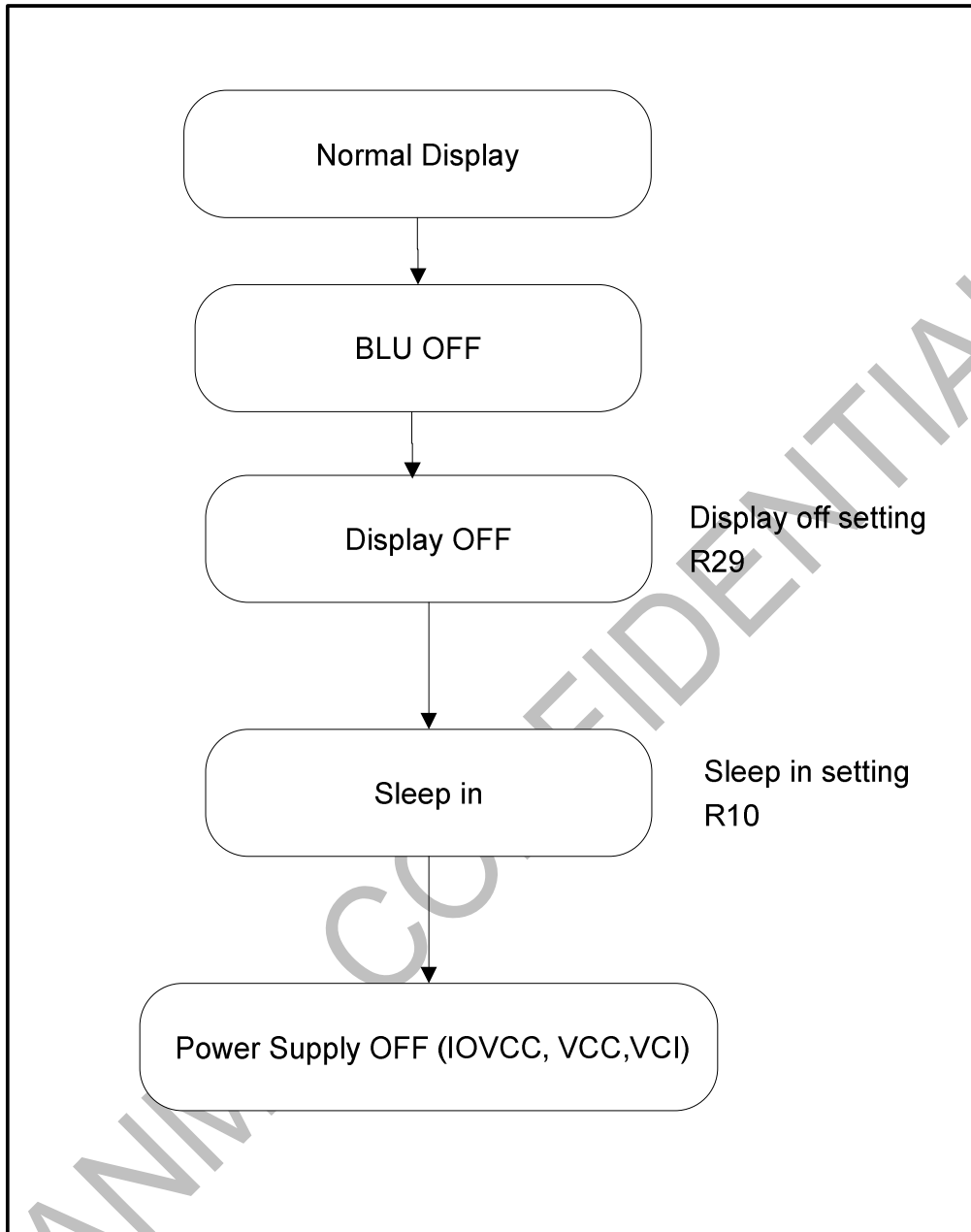



## 6 Optical Characteristics

Ta=25°C

Item	Symbol	Condition	Min	Typ	Max	Unit	Remark	
View Angles	$\theta T$	$CR \geq 10$	60	70	-	Degree	Note 2	
	$\theta B$		50	60	-			
	$\theta L$		60	70	-			
	$\theta R$		60	70	-			
Contrast Ratio	CR	$\theta=0^\circ$	400	500	-	-	Note1 Note3	
Response Time	$T_{ON}$	25°C	-	20	30	ms	Note1	
	$T_{OFF}$						Note4	
Chromaticity	White	Backlight is on	x	0.248	0.298	0.348	-	Note5 Note1
			y	0.266	0.316	0.366		
	Red		x	0.562	0.592	0.662		
			y	0.297	0.347	0.397		
	Green		x	0.282	0.332	0.382		
			y	0.505	0.552	0.605		
	Blue		x	0.092	0.142	0.192		
			y	0.041	0.091	0.141		
Uniformity	U	-	75	80	-	%	Note1 Note6	
NTSC	-	-	-	50	-	%	Note 5	
Luminance	L	-	200	250	-	cd/m <sup>2</sup>	Note1 Note7	

Test Conditions:

1.  $V_F=3.2V$ ,  $I_F=20mA$ (One LED current), the ambient temperature is 25°C.
2. The test systems refer to Note 1 and Note 2.



Note 1: Definition of optical measurement system.

The optical characteristics should be measured in dark room. After 5 minutes operation, the optical properties are measured at the center point of the LCD screen. All input terminals LCD panel must be ground when measuring the center area of the panel.

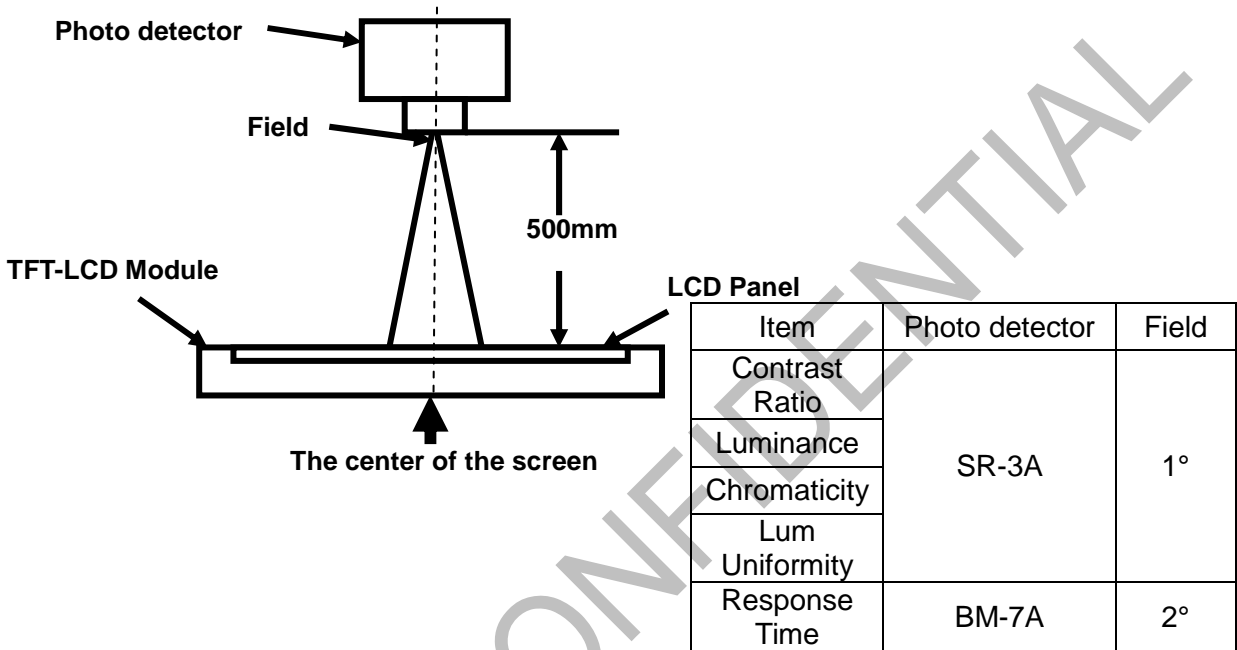

Note 2: Definition of viewing angle range and measurement system.

viewing angle is measured at the center point of the LCD by CONOSCOPE(ergo-80).

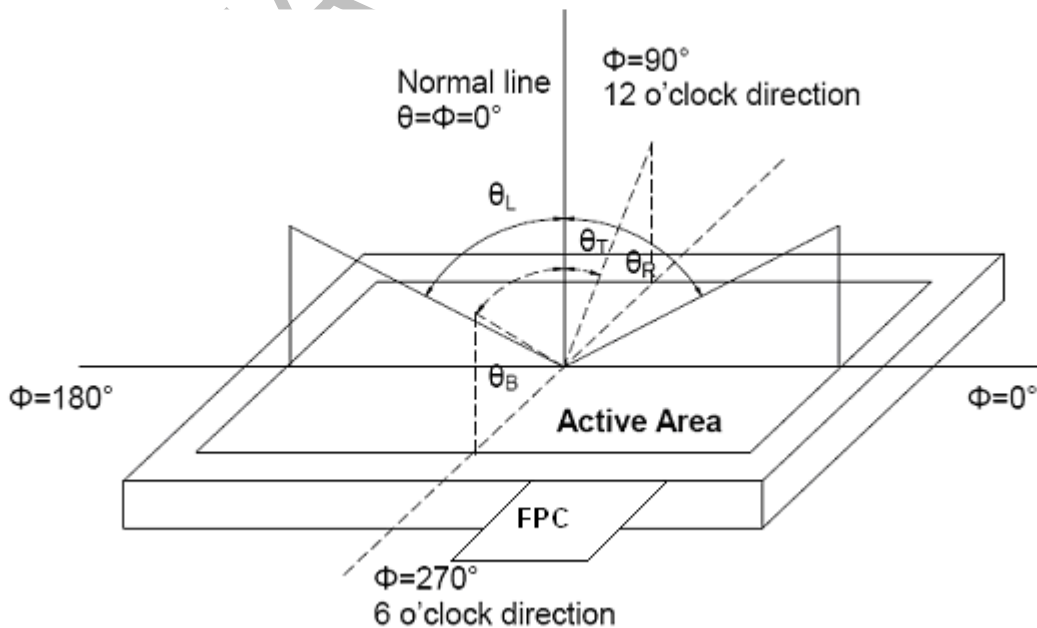

Fig. 1 Definition of viewing angle

The information contained herein is the exclusive property of SHANGHAI TIANMA MICRO-ELECTRONICS Corporation, and shall not be distributed, reproduced, or disclosed in whole or in part without prior written permission of SHANGHAI TIANMA MICRO-ELECTRONICS Corporation.



Note 3: Definition of contrast ratio

$$\text{Contrast ratio (CR)} = \frac{\text{Luminance measured when LCD is on the "White" state}}{\text{Luminance measured when LCD is on the "Black" state}}$$

"White state": The state is that the LCD should be driven by  $V_{\text{white}}$ .

"Black state": The state is that the LCD should be driven by  $V_{\text{black}}$ .

$V_{\text{white}}$ : To be determined     $V_{\text{black}}$ : To be determined.

Note 4: Definition of Response time

The response time is defined as the LCD optical switching time interval between "White" state and "Black" state. Rise time ( $T_{\text{ON}}$ ) is the time between photo detector output intensity changed from 90% to 10%. And fall time ( $T_{\text{OFF}}$ ) is the time between photo detector output intensity changed from 10% to 90%.

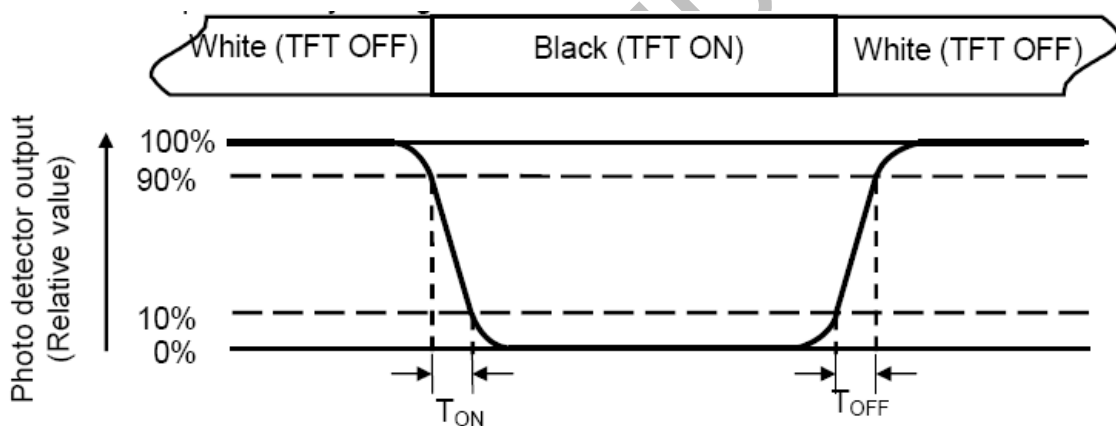

Note 5: Definition of color chromaticity (CIE1931)

Color coordinates measured at center point of LCD.

**Note 6: Definition of Luminance Uniformity**

Active area is divided into 9 measuring areas (Refer Fig. 2). Every measuring point is placed at the center of each measuring area.

$$\text{Luminance Uniformity}(U) = L_{\min} / L_{\max}$$

L-----Active area length W----- Active area width

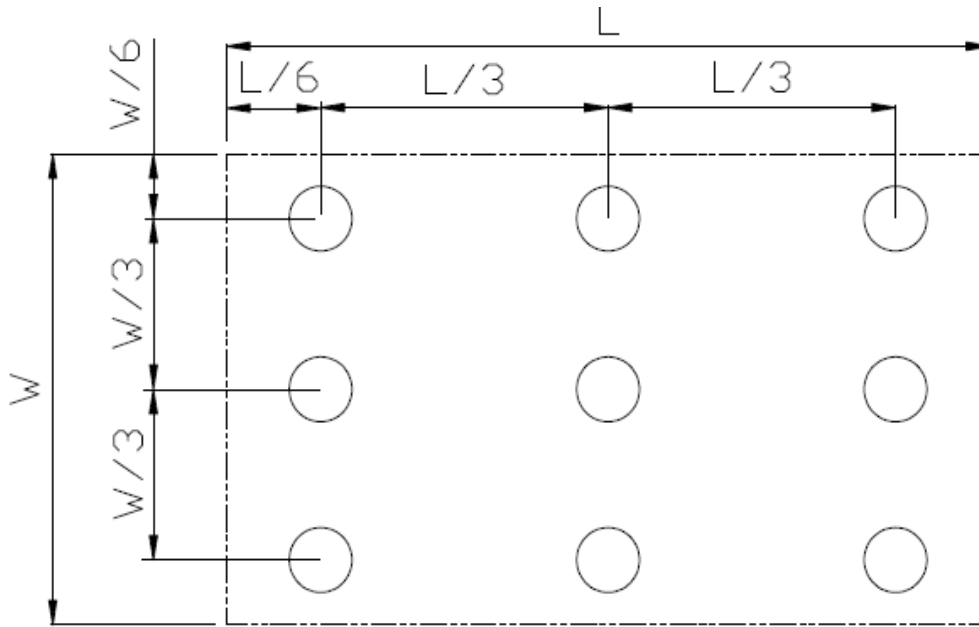

Fig. 2 Definition of uniformity

$L_{\max}$ : The measured maximum luminance of all measurement position.

$L_{\min}$ : The measured minimum luminance of all measurement position.

**Note 7: Definition of Luminance :**

Measure the luminance of white state at center point.



## 7 Environmental / Reliability Test

No	Test Item	Condition	Remarks
1	High Temperature Operation	Ts=+70°C, 240hrs	Note1 IEC60068-2-1,GB2423.2
2	Low Temperature Operation	Ta=-20°C, 240hrs	IEC60068-2-1 GB2423.1
3	High Temperature Storage	Ta=+80°C, 240hrs	IEC60068-2-1 GB2423.2
4	Low Temperature Storage	Ta=-30°C, 240hrs	IEC60068-2-1 GB2423.1
5	High Temperature & High Humidity Storage	Ta=+60°C, 90% RH 240 hours	Note2 IEC60068-2-78 GB/T2423.3
6	Thermal Shock (Non-operation)	-30°C 30 min~+70°C 30 min, Change time:5min, 20 Cycles	Start with cold temperature, End with high temperature, IEC60068-2-14,GB2423.22
7	Electro Static Discharge (Operation)	C=150pF, R=330Ω, 5points/panel Air:±8KV, 5times; Contact:±4KV, 5 times; (Environment: 15°C~35°C, 30%~60%, 86Kpa~106Kpa)	IEC61000-4-2 GB/T17626.2
8	Vibration (Non-operation)	Frequency range:10~55Hz, Stroke:1.5mm Sweep:10Hz~55Hz~10Hz 2 hours for each direction of X.Y.Z. (6 hours for total)(Package condition)	IEC60068-2-6 GB/T2423.10
9	Shock (Non-operation)	60G 6ms, ±X,±Y,±Z 3times, for each direction	IEC60068-2-27 GB/T2423.5
10	Package Drop Test	Height:80 cm, 1 corner, 3 edges, 6 surfaces	IEC60068-2-32 GB/T2423.8
11	Package Vibration Test	Random Vibration: 0.015GxG/Hz for 5-200Hz, -6dB/Octave from 200-500Hz 2 hours for each direction of X,Y,Z (6 hours for total)	IEC60068-2-34 GB/T2423.11

Note1: Ts is the temperature of panel's surface.

Note2: Ta is the ambient temperature of sample.



# 8 Mechanical Drawing

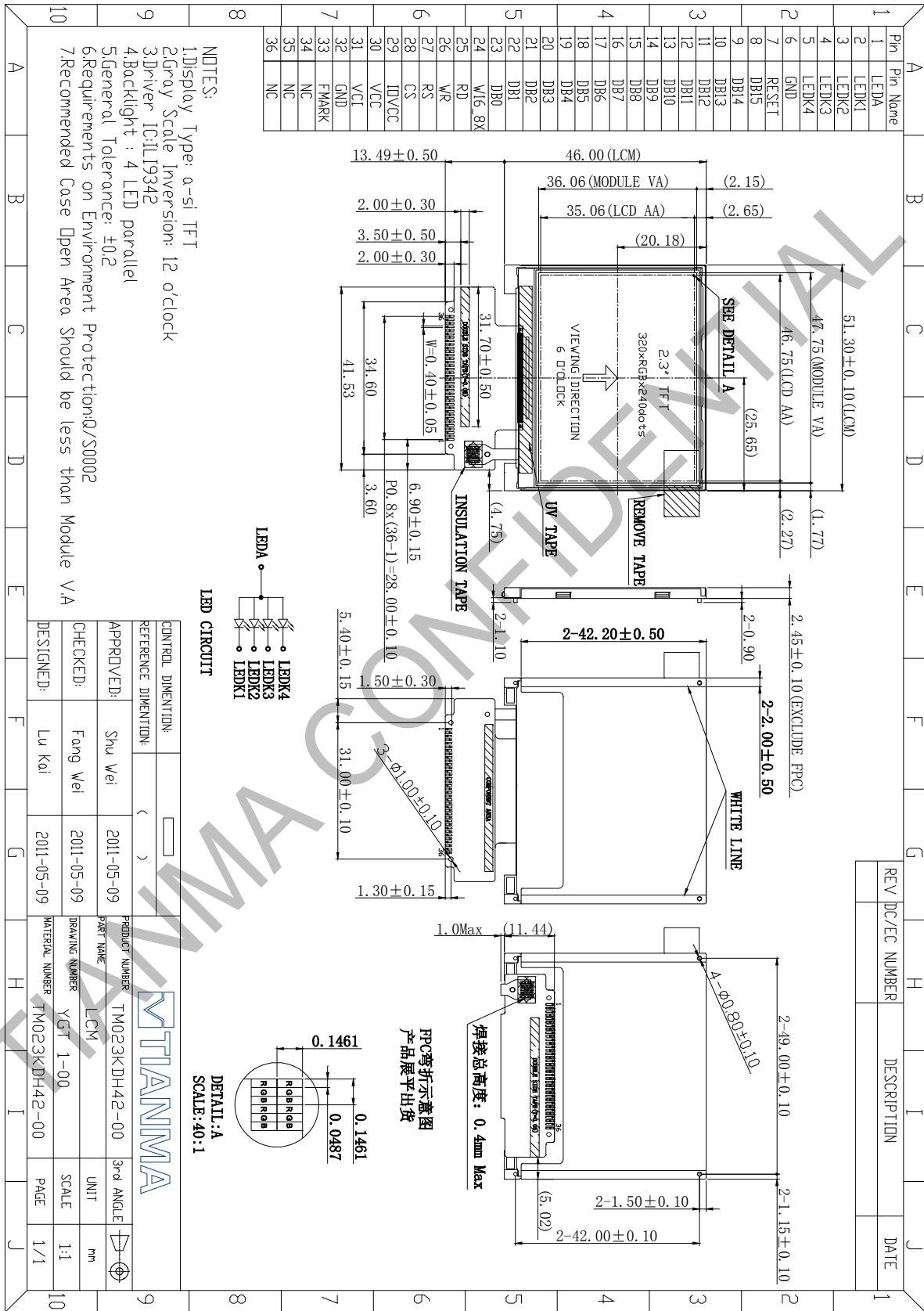

The information contained herein is the exclusive property of SHANGHAI TIANMA MICRO-ELECTRONICS Corporation, and shall not be distributed, reproduced, or disclosed in whole or in part without prior written permission of SHANGHAI TIANMA MICRO-ELECTRONICS Corporation.



## 9 Packing Drawing

No	Item	Model (Material)	Dimensions(mm)	Unit Weight(Kg)	Quantity	Remark
1	LCM module	TM023KDH42	51.30*46.00*2.45	0.0108	714	
2	Tray	PET (Transmit)	485*330*14.2	0.167	24	Anti-static
3	EPE	EPE	485*330*5	0.019	3	
4	Vacuum Bag	PE	600*500*0.08	0.047	3	
5	Box	Corrugated paper	520*345*74	0.3879	3	
6	Desiccant	Desiccant	45*35	0.002	6	
7	Carton	Corrugated paper	544*365*250	0.76	1	
8	Label	Paper	100*52	--	4	
9	Total weight	13.85 Kg				





Two Desiccants  
+  
Use empty tray  
+  
Put products into  
the 7 trays  
\* 34 LCMs per tray

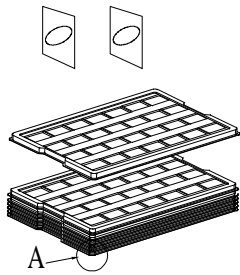

Detail A

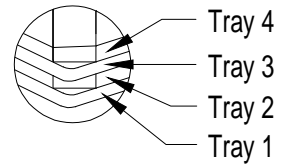

Rotate tray 180 degrees  
and place on top of stack.  
Check the tray using Fig.A

Use strop

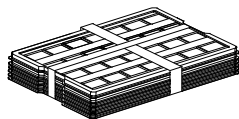

8 Trays in Vacuum  
Bag(vacuumize)

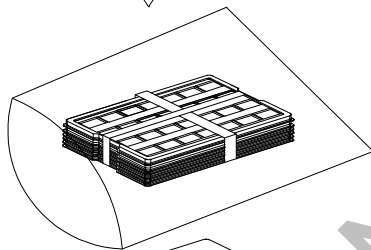

+  
EPE

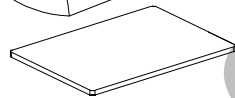

238 LCMs per Box

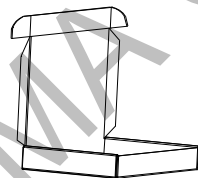

Label

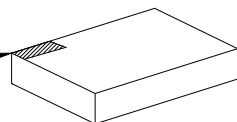

Use the tape to seal Carton

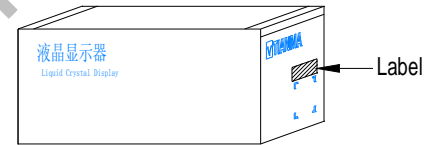
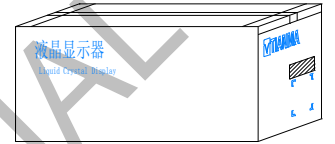

Put into Carton

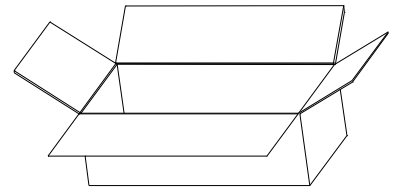

3 Box  
3 Label

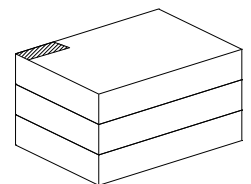



## 10 Precautions For Use of LCD Modules

### 10.1 Handling Precautions

- 10.1.1 The display panel is made of glass. Do not subject it to a mechanical shock by dropping it from a high place, etc.
- 10.1.2 If the display panel is damaged and the liquid crystal substance inside it leaks out, be sure not to get any in your mouth, if the substance comes into contact with your skin or clothes, promptly wash it off using soap and water.
- 10.1.3 Do not apply excessive force to the display surface or the adjoining areas since this may cause the color tone to vary.
- 10.1.4 The polarizer covering the display surface of the LCD module is soft and easily scratched. Handle this polarizer carefully.
- 10.1.5 If the display surface is contaminated, breathe on the surface and gently wipe it with a soft dry cloth. If still not completely clear, moisten cloth with one of the following solvents:
  - Isopropyl alcohol
  - Ethyl alcoholSolvents other than those mentioned above may damage the polarizer. Especially, do not use the following:
  - Water
  - Ketone
  - Aromatic solvents
- 10.1.6 Do not attempt to disassemble the LCD Module.
- 10.1.7 If the logic circuit power is off, do not apply the input signals.
- 10.1.8 To prevent destruction of the elements by static electricity, be careful to maintain an optimum work environment.
  - 10.1.8.1 Be sure to ground the body when handling the LCD Modules.
  - 10.1.8.2 Tools required for assembly, such as soldering irons, must be properly ground.
  - 10.1.8.3 To reduce the amount of static electricity generated, do not conduct assembly and other work under dry conditions.
  - 10.1.8.4 The LCD Module is coated with a film to protect the display surface. Be care when peeling off this protective film since static electricity may be generated.

### 10.2 Storage precautions

- 10.2.1 When storing the LCD modules, avoid exposure to direct sunlight or to the light of fluorescent lamps.
- 10.2.2 The LCD modules should be stored under the storage temperature range. If the LCD modules will be stored for a long time, the recommend condition is:  
Temperature : 0°C ~ 40°C      Relatively humidity: ≤80%
- 10.2.3 The LCD modules should be stored in the room without acid, alkali and harmful gas.

### 10.3 Transportation Precautions

The LCD modules should be no falling and violent shocking during transportation, and also should avoid excessive press, water, damp and sunshine.