



MODEL NO. : TM032LDH05

ISSUED DATE: 2009-2-18



VERSION : Ver 1.0

- Preliminary Specification
- Final Product Specification

Customer : \_\_\_\_\_

Approved by	Notes

SHANGHAI TIANMA Confirmed :

Prepared by	Checked by	Approved by
 2009.3.9	 2009.3.9.	 09/3/9

This technical specification is subjected to change without notice

The information contained herein is the exclusive property of SHANGHAI TIANMA MICRO-ELECTRONICS Corporation, and shall not be distributed, reproduced, or disclosed in whole or in part without prior written permission of SHANGHAI TIANMA MICRO-ELECTRONICS Corporation.



## Table of Contents

Coversheet.....	1
Table of Contents.....	2
Record of Revision.....	3
1 General Specifications .....	4
2 Input/Output Terminals .....	5
3 Absolute Maximum Ratings .....	7
4 Electrical Characteristics.....	8
5 Timing Chart.....	10
6 Optical Characteristics .....	20
7 Environmental / Reliability Tests.....	24
8 Mechanical Drawing.....	25
9 Packing Drawing .....	26
10 Precautions for Use of LCD Modules.....	27



### Record of Revision

Rev	Issued Date	Description	Editor
1.0	2009-2-18	Preliminary Specification Release	Xinhua Kang

The information contained herein is the exclusive property of SHANGHAI TIANMA MICRO-ELECTRONICS Corporation, and shall not be distributed, reproduced, or disclosed in whole or in part without prior written permission of SHANGHAI TIANMA MICRO-ELECTRONICS Corporation.



## 1 General Specifications

	Feature	Spec
<b>Display Spec.</b>	Size	3.2 inch
	Resolution	240(RGB) x 400
	Interface	CPU 18 bits/16 bits/8 bits
	Color Depth	262K/65K
	Technology Type	a-Si
	Pixel Pitch (mm)	0.174X0.174
	Pixel Configuration	R.G.B. Vertical Stripe
	Display Mode	TM with Normally White
	Surface Treatment(Up Polarizer)	Clear Type(3H)
	Viewing Direction	6 o'clock
	Gray Scale Inversion Direction	12 o'clock
<b>Mechanical Characteristics</b>	LCM (W x H x D) (mm)	47.60x80.90x2.6
	Active Area(mm)	41.76x69.60
	With /Without TSP	Without TSP
	Weight (g)	TBD
	LED Numbers	4 LEDs
<b>Electronic</b>	Driver IC	HX8352-A

Note 1: Viewing direction for best image quality is different from TFT definition, there is a 180 degree shift.

Note 2: Requirements on Environmental Protection: RoHS

Note 3: LCM weight tolerance : +/- 5%



## 2 Input/Output Terminals

### 2.1 TFT LCD Panel

No	SYMBOL	I/O	Description	Remark
1	GND	P	Ground	
2	NC/YD	--	Reserved	
3	NC/XR	--	Reserved	
4	NC/YU	--	Reserved	
5	NC/XL	--	Reserved	
6	GND	P	Ground	
7	BS1	I	Interface selection	Note 2
8	BS0	I	Interface selection	Note 2
9	FMARK/NC	O	Tearing effect output. If not used, please open this pin	
10	PWM_OUT/N C	O	PWM control signal output	
11	LCD_ID	O	ID pin,2.783V(under typical input voltage 2.8V)	
12	RESET	I	Reset signal; Must be reset after power is supplied	
13	D17	I	Data input	
14	D16	I	Data input	
15	D15	I	Data input	
16	D14	I	Data input	
17	D13	I	Data input	
18	D12	I	Data input	
19	D11	I	Data input	
20	D10	I	Data input	
21	D9	I	Data input	
22	D8	I	Data input	
23	D7	I	Data input	
24	D6	I	Data input	
25	D5	I	Data input	
26	D4	I	Data input	
27	D3	I	Data input	
28	D2	I	Data input	
29	D1	I	Data input	
30	D0	I	Data input	
31	RD	I	Read signal	
32	WR	I	Write signal	
33	RS	I	Command or parameter select signal; Low: command; High: parameter	
34	CS	I	Chip select signal, low: chip can be accessed; Must be connected to GND if not used	
35	GND	P	Ground	
36	IOVCC	P	Digital I/O power supply	
37	VCC	P	Digital power supply	

The information contained herein is the exclusive property of SHANGHAI TIANMA MICRO-ELECTRONICS Corporation, and shall not be distributed, reproduced, or disclosed in whole or in part without prior written permission of SHANGHAI TIANMA MICRO-ELECTRONICS Corporation.



38	NC	--	No connection	
39	LEDK4	P	Back light cathode LEDK4	
40	LEDK3	P	Back light cathode LEDK3	
41	LEDK2	P	Back light cathode LEDK2	
42	LEDK1	P	Back light cathode LEDK1	
43	LEDA	P	Back light cathode LEDA	
44	GND	P	Ground	

Note 1: I/O definition:

I---Input    O---Output    P---Power(Ground)    NC---No connection

Note 2: Interface selection:

BS1	BS0	Interface Mode	DB Pins
0	0	16-bit bus interface,80-system, 65K-color	D15-D0: Data ; D17-D16: Unused
0	1	16-bit bus interface,80-system, 262K-color	D15-D0: Data ; D17-D16: Unused
1	0	18-bit bus interface,80-system, 262K-color	D17-D0: Data
1	1	8-bit bus interface,80-system, 262K-color	D7-D0: Data ; D17-D8: Unused



### 3 Absolute Maximum Ratings

#### 3.1 Driving TFT LCD Panel

Ta = 25°C

Item	Symbol	Min.	Max.	Unit	Remark
Supply Voltage	VCC	-0.3	4.6	V	
Supply Voltage	IOVCC	-0.3	4.6	V	
Input Signal Voltage	D[17: 0], CS, RD, WR, RS, RESET, BS[1:0]	-0.3	VCC +0.3	V	
Back Light Forward Current	I <sub>LED</sub>	--	25	mA	For each LED
Operating Temperature	T <sub>OPR</sub>	-20	70	°C	
Storage Temperature	T <sub>STG</sub>	-30	80	°C	



## 4 Electrical Characteristics

### 4.1 Driving TFT LCD Panel

GND=0V, Ta=25°C

Item	Symbol	Min.	Typ.	Max.	Unit	Remark
Supply Voltage	VCC	2.5	2.8	3.3	V	
Supply voltage	IOVCC	1.65	2.8	3.3	V	
Input Signal Voltage	Low Level	V <sub>IL</sub>	0	--	0.2xIOVCC	D[17: 0], CS, RD, WR, RS, RESET, BS[1:0]
	High Level	V <sub>IH</sub>	0.8xIOVCC	--	IOVCC	
Output Signal Voltage	Low Level	V <sub>OL</sub>	-0.3	--	0.3xIOVCC	FMARK/NC, PWM_OUT/NC
	High Level	V <sub>OH</sub>	0.7xIOVCC	--	IOVCC	
(Panel+ LSI) Power Consumption	Black Mode (60Hz)	--	TBD	--	mA	
	8 color Mode	--	TBD	--	mA	
	Standby Mode	--	TBD	--	uA	

### 4.2 Driving Backlight

Ta=25°C

Item	Symbol	Min.	Typ.	Max.	Unit	Remark
Forward Current	I <sub>F</sub>	--	80	100	mA	4LEDs ( in parallel)
Forward Voltage	V <sub>F</sub>	--	3.2	--	V	
Power Consumption	W <sub>BL</sub>	--	256	--	mW	

Note1: Figure below shows the connection of backlight LED.

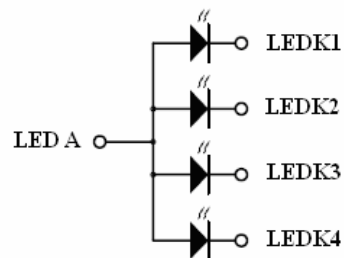

Note 2: One LED : I<sub>F</sub> =20mA, V<sub>F</sub> =3.2V

Note 3: The life of LED : 20,000 hours





### 4.3 Block Diagram

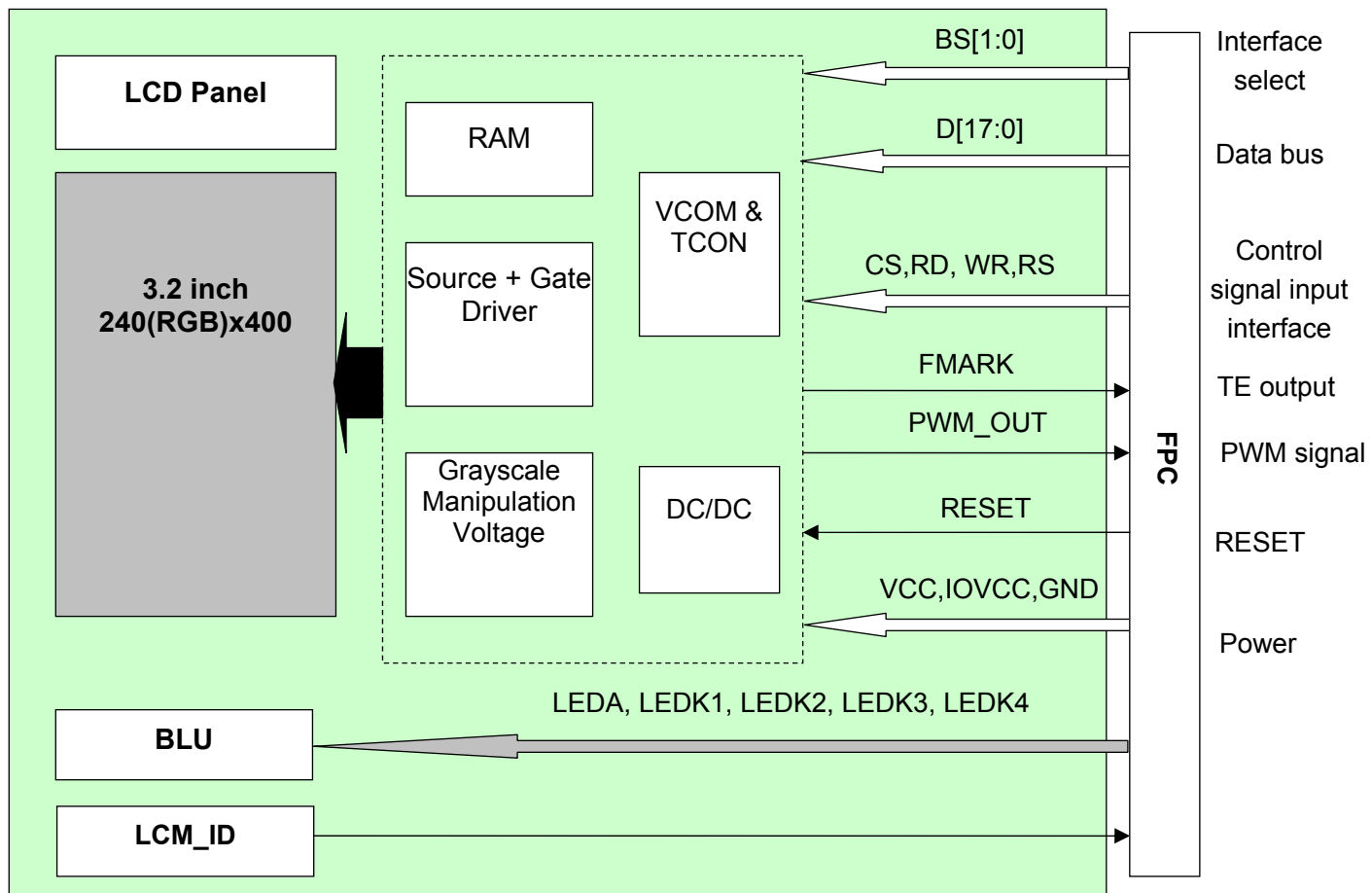



## 5 Timing Chart

### 5.1 Interface Characteristics

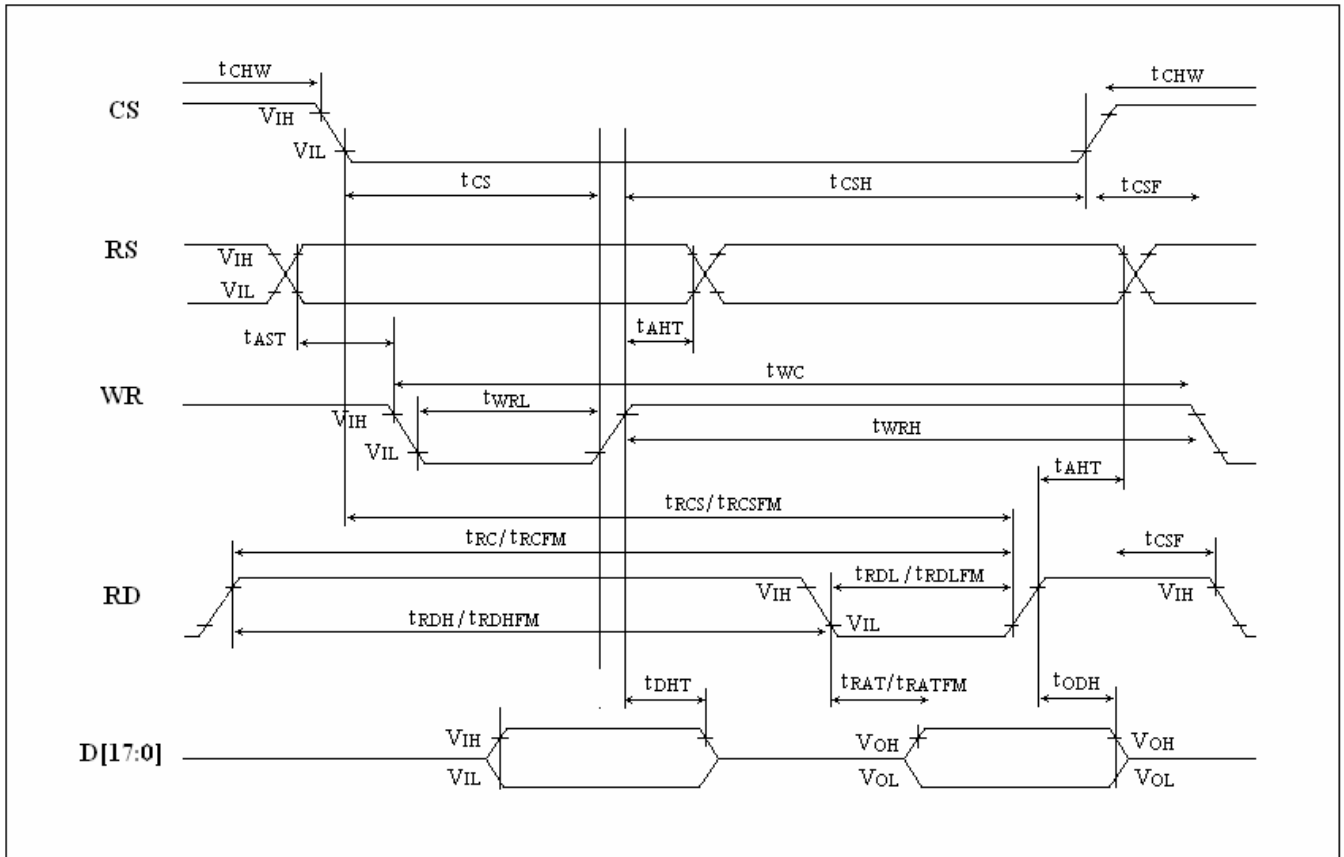

The information contained herein is the exclusive property of SHANGHAI TIANMA MICRO-ELECTRONICS Corporation, and shall not be distributed, reproduced, or disclosed in whole or in part without prior written permission of SHANGHAI TIANMA MICRO-ELECTRONICS Corporation.



## 5.2 Interface Timing Parameters

### Normal Write Mode

Signal	Symbol	Parameter	Spec.			Description
			Min.	Max.	Unit	
RS	$t_{AST}$	Address setup time	10	-	ns	-
	$t_{AHT}$	Address hold time(Write/Read)	10	-		
CS	$t_{CHW}$	Chip select "H" pulse width	0	-	ns	-
	$t_{CS}$	Chip select setup time (Write)	35	-		
	$t_{RCS}$	Chip select setup time (Read ID)	100	-		
	$t_{RCSFM}$	Chip select setup time (Read FM)	100	-		
	$t_{CSF}$	Chip select wait time(Write/Read)	10	-		
WR	$t_{WC}$	Write cycle	100	-	ns	-
	$t_{WRH}$	Control pulse "H" duration	20	-		
	$t_{WRL}$	Control pulse "L" duration	20	-		
RD	$t_{RC}$	Read cycle (ID)	150	-	ns	When read ID data
	$t_{RDH}$	Control pulse "H" duration (ID)	40	-		
	$t_{RDL}$	Control pulse "L" duration (ID)	50	-		
RD	$t_{RCFM}$	Read cycle (FM)	250	-	ns	When read from frame memory
	$t_{RDHFM}$	Control pulse "H" duration (FM)	50	-		
	$t_{RDLFM}$	Control pulse "L" duration (FM)	150	-		
D[17:0]	$t_{DST}$	Data setup time	20	-	ns	For maximum $C_L=30pF$ For minimum $C_L=8pF$
	$t_{DHT}$	Data hold time	20	-		
	$t_{RAT}$	Read access time (ID)	-	70		
	$t_{RATFM}$	Read access time (FM)	-	100		
	$t_{ODH}$	Output disable time	20	80		



### 5.3 Interface Register Write/Read Timing

#### 5.3.1 System Bus Interface Register Write Timing

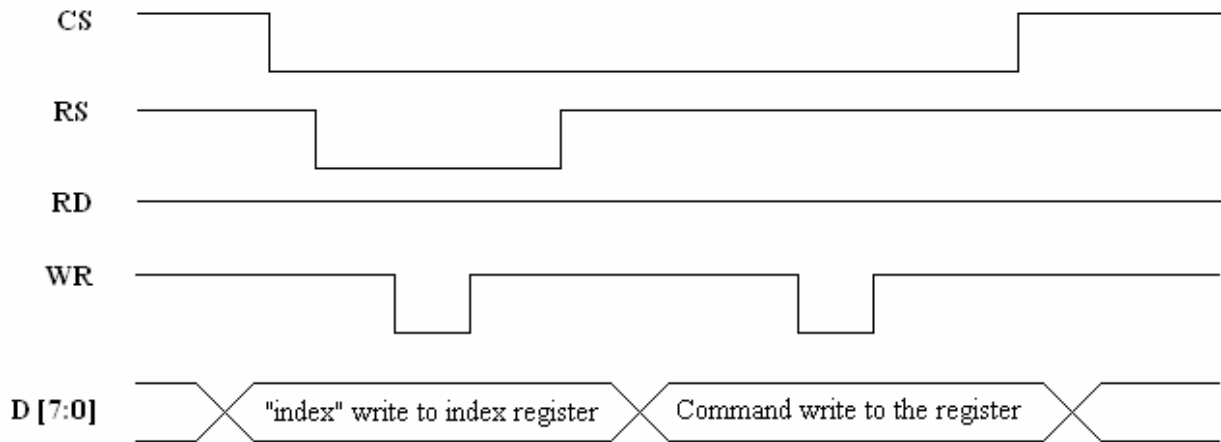

#### 5.3.2 System Bus Interface Register Read Timing

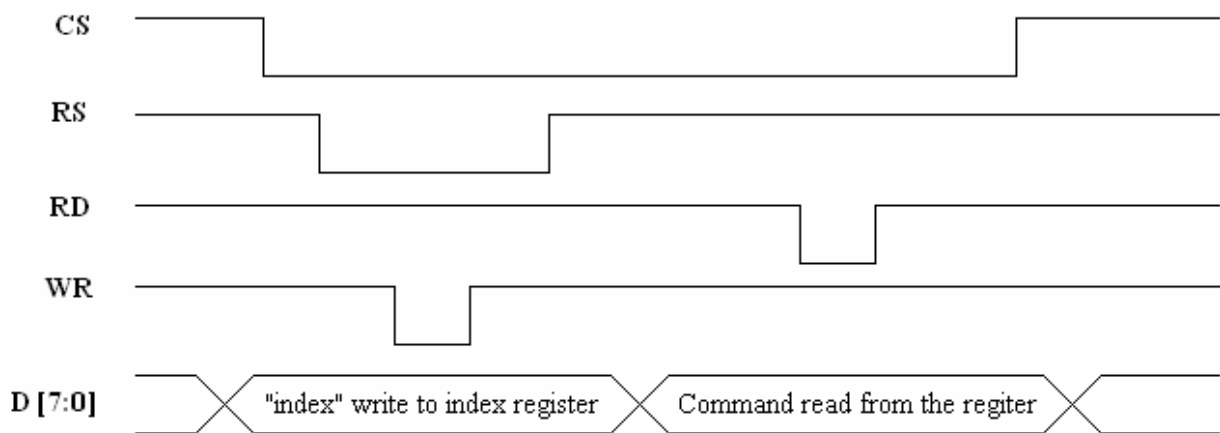



5.4 GRAM Write/Read Data Format

5.4.1 18-bit Read/Write GRAM Data Format(262K)

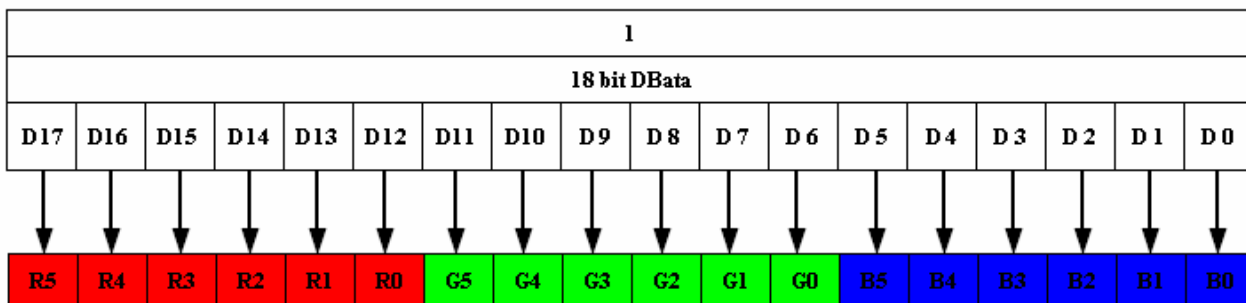

5.4.2 16-bit Read/Write GRAM Data Format(262K/65K)

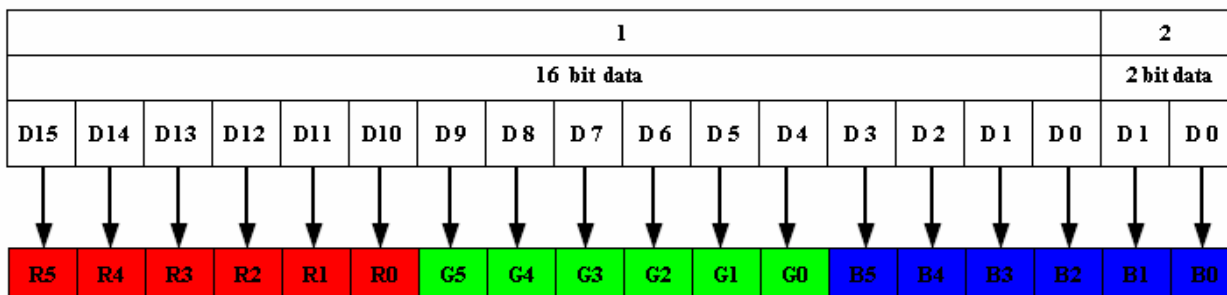

16-bit Data Bus GRAM Write/Read Data Format (16+2bit, 262k)

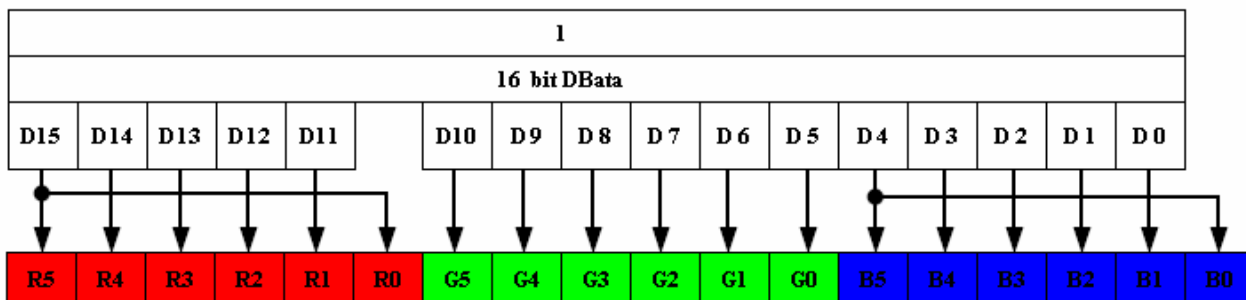

16-bit Data Bus GRAM Write/Read Data Format (16bit, 65k)

The information contained herein is the exclusive property of SHANGHAI TIANMA MICRO-ELECTRONICS Corporation, and shall not be distributed, reproduced, or disclosed in whole or in part without prior written permission of SHANGHAI TIANMA MICRO-ELECTRONICS Corporation.



### 5.4.3 8-bit Read/Write GRAM Data Format(262K)

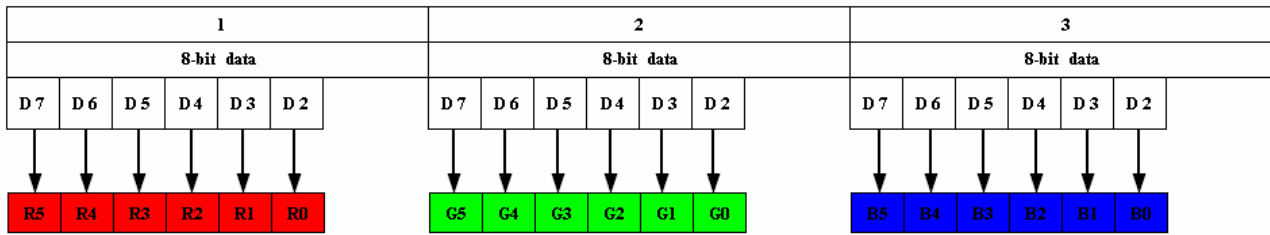

## 5.5 Data Bus GRAM Write/Read Timing

### 5.5.1 18-bit Data Bus GRAM Write/Read Timing(262k)

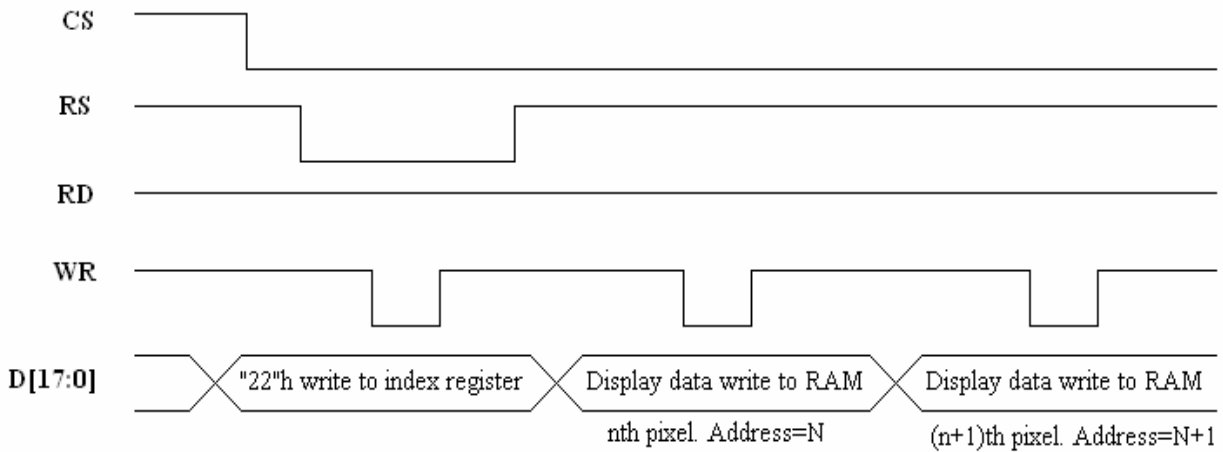

### 18-bit Data Bus GRAM Write Timing(262k)

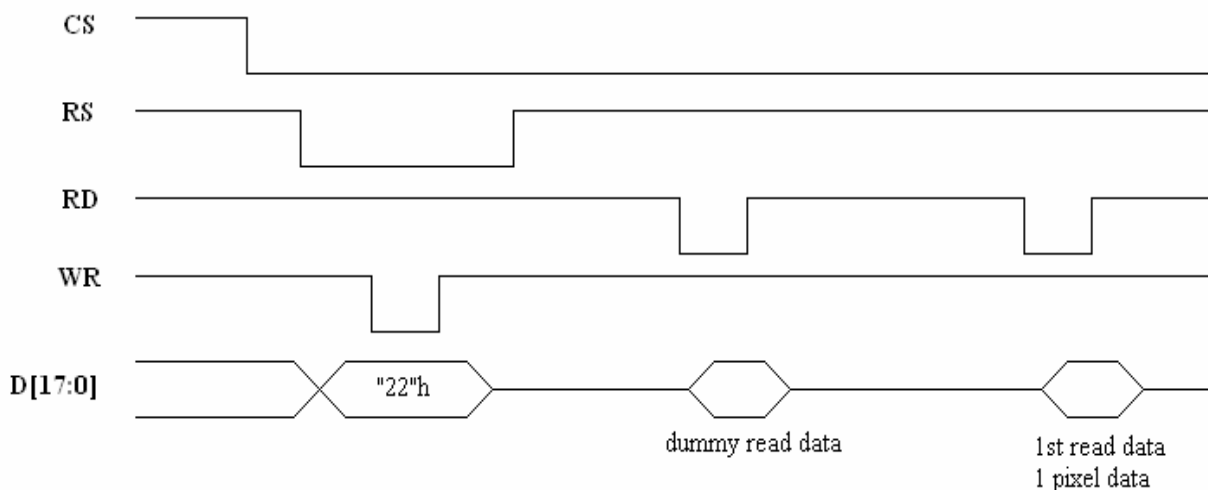

### 18-bit Data Bus GRAM Read Timing(262k)

The information contained herein is the exclusive property of SHANGHAI TIANMA MICRO-ELECTRONICS Corporation, and shall not be distributed, reproduced, or disclosed in whole or in part without prior written permission of SHANGHAI TIANMA MICRO-ELECTRONICS Corporation.



5.5.2 16-bit Data Bus GRAM Write/Read Timing(262k/65k)

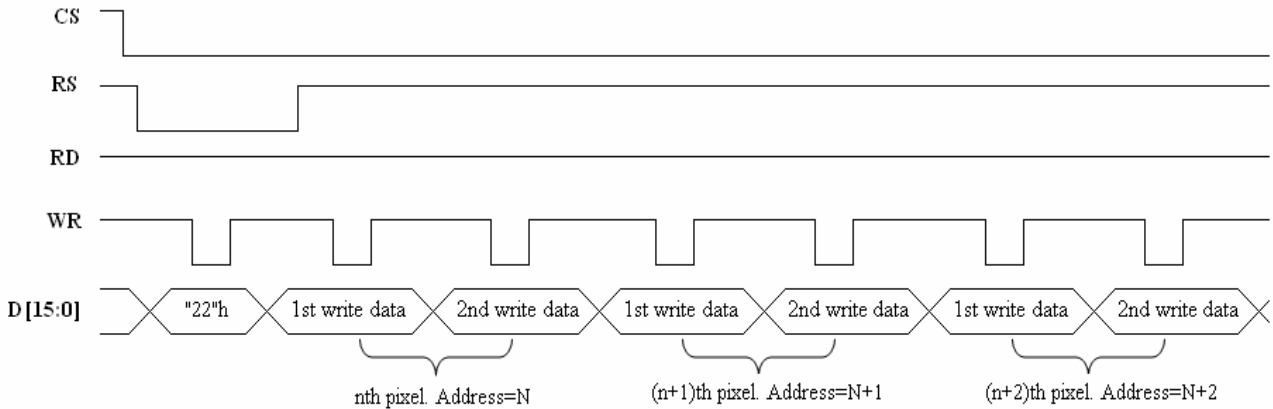

16-bit Data Bus GRAM Write Timing(16+2bit,262k)

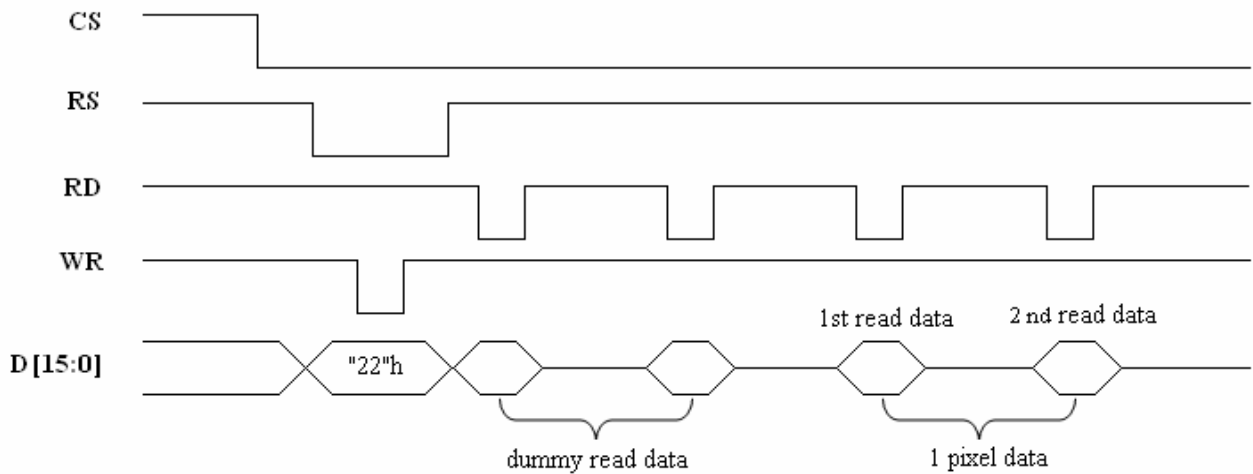

16-bit Data Bus GRAM Read Timing(16+2bit,262k)

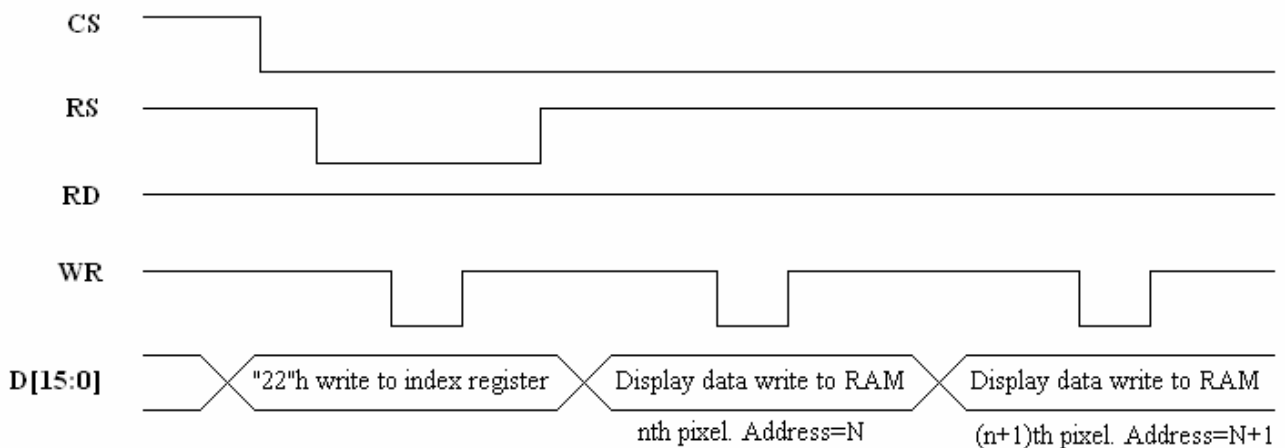

16-bit Data Bus GRAM Write Timing(16bit,65k)

The information contained herein is the exclusive property of SHANGHAI TIANMA MICRO-ELECTRONICS Corporation, and shall not be distributed, reproduced, or disclosed in whole or in part without prior written permission of SHANGHAI TIANMA MICRO-ELECTRONICS Corporation.

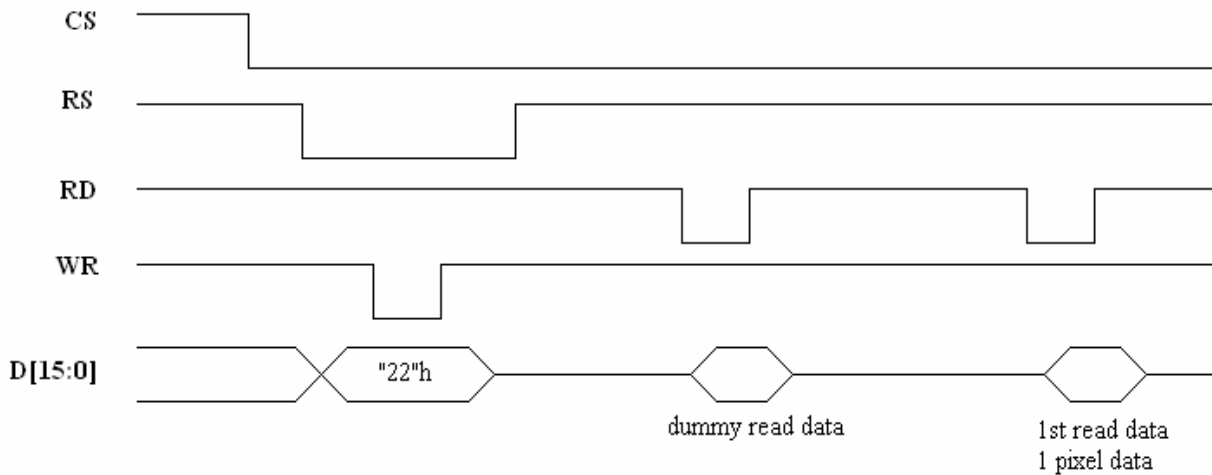

16-bit Data Bus GRAM Read Timing(16bit,65k)

5.5.3 8-bit Data Bus GRAM Write/Read Timing(262k)

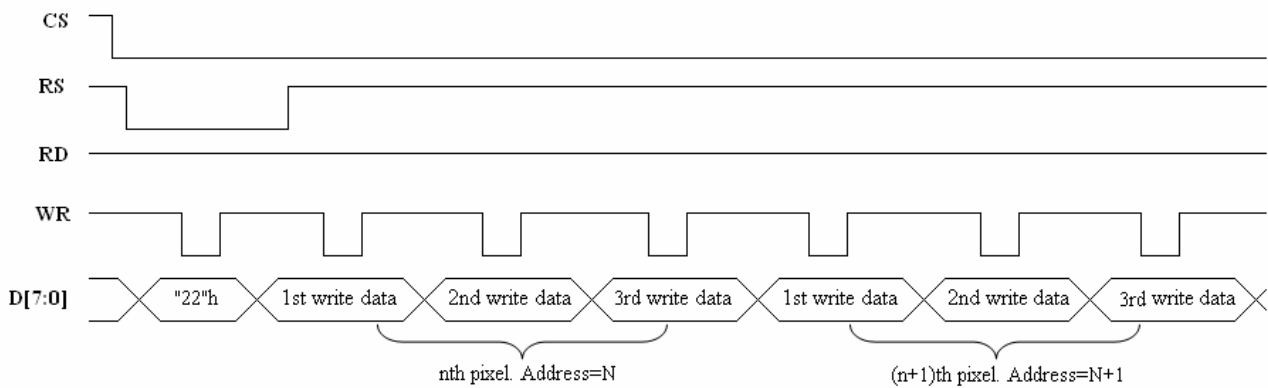

8-bit Data Bus GRAM Write Timing(6+6+6bit,262k)

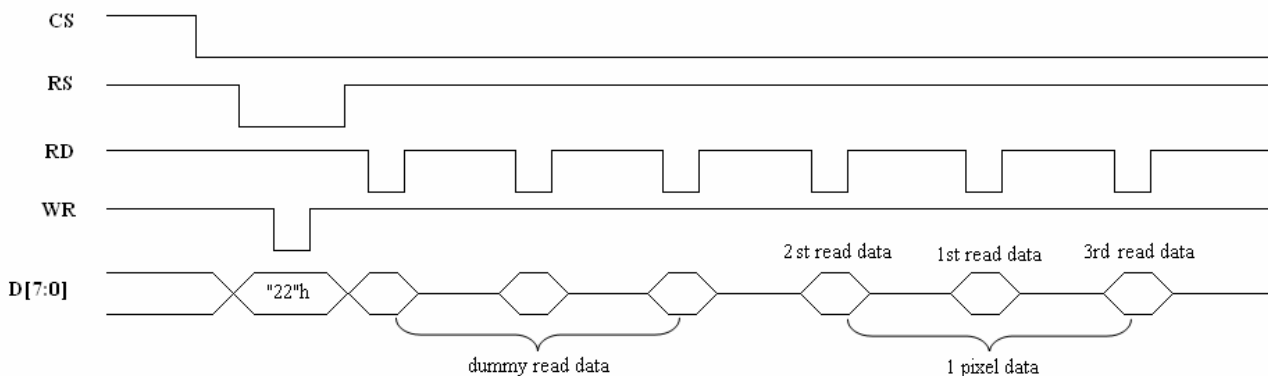

8-bit Data Bus GRAM Read Timing(6+6+6bit,262k)

The information contained herein is the exclusive property of SHANGHAI TIANMA MICRO-ELECTRONICS Corporation, and shall not be distributed, reproduced, or disclosed in whole or in part without prior written permission of SHANGHAI TIANMA MICRO-ELECTRONICS Corporation.





## 5.6 Reset Timing Characteristics

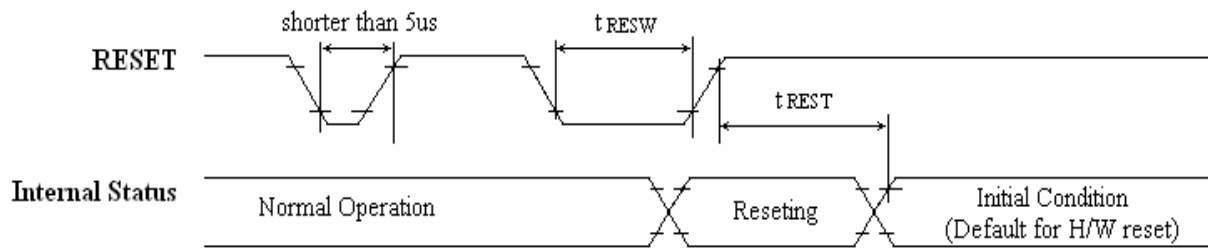

Reset Input Timing

### Reset Timing Parameters

Symbol	Parameter	Related Pins	Spec.			Note	Unit
			Min.	Typ.	Max.		
$t_{RESW}$	Reset low pulse width	RESET	10	-	-	-	us
$t_{REST}$	Reset complete time	-	-	-	5	When reset applied during "Sleep In mode"	ms
		-	-	-	120	When reset applied during "Sleep Out mode"	ms

Note 1:

RESET Pulse	Action
Shorter than 5 $\mu$ s	Shorter than 5 $\mu$ s
Longer than 10 $\mu$ s	Reset
Between 5 $\mu$ s and 10 $\mu$ s	Reset Start



## 5.7 Power On/Off Sequence

### 5.7.1 Power on Sequence

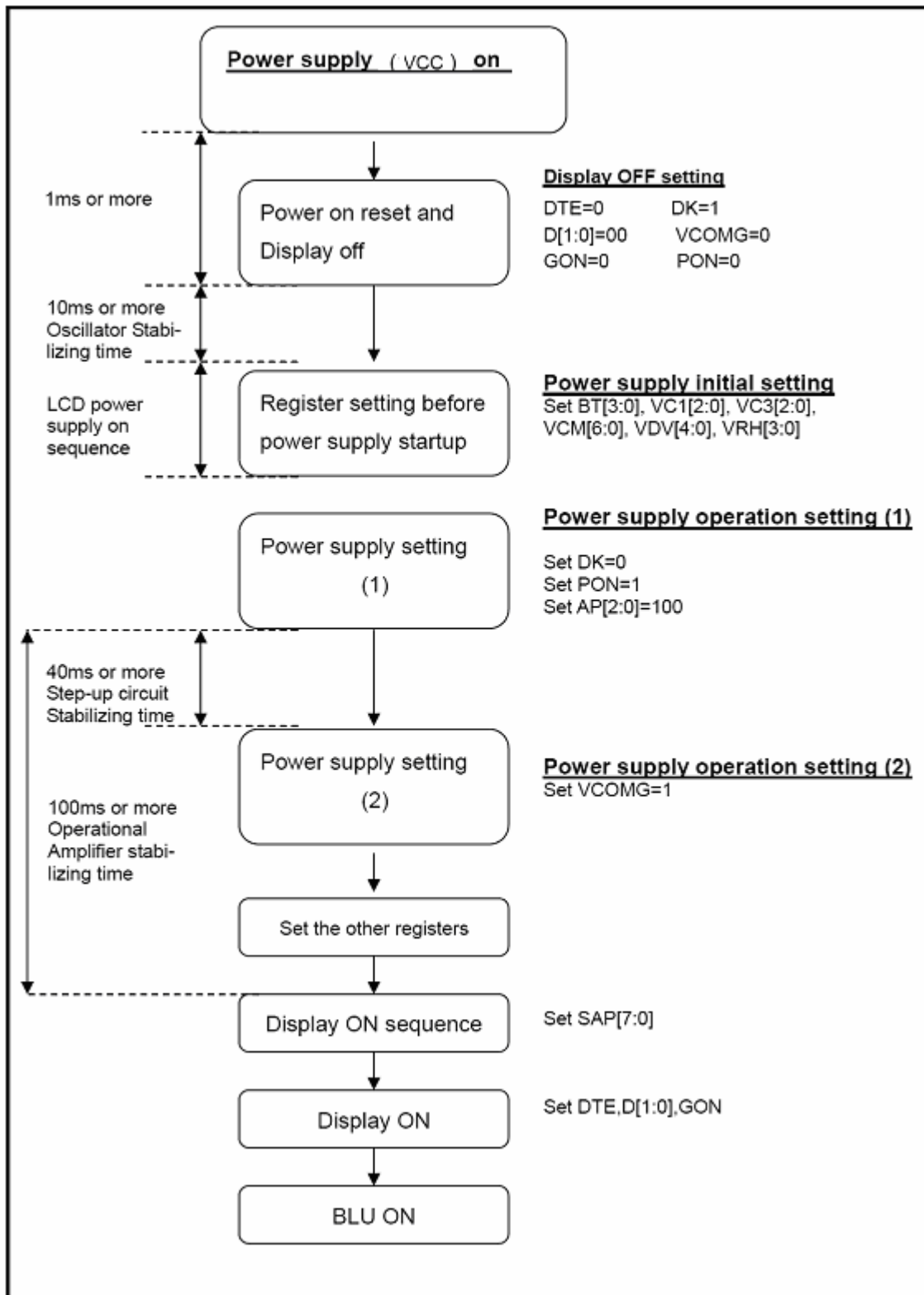

The information contained herein is the exclusive property of SHANGHAI TIANMA MICRO-ELECTRONICS Corporation, and shall not be distributed, reproduced, or disclosed in whole or in part without prior written permission of SHANGHAI TIANMA MICRO-ELECTRONICS Corporation.



5.7.2 Power off Sequence

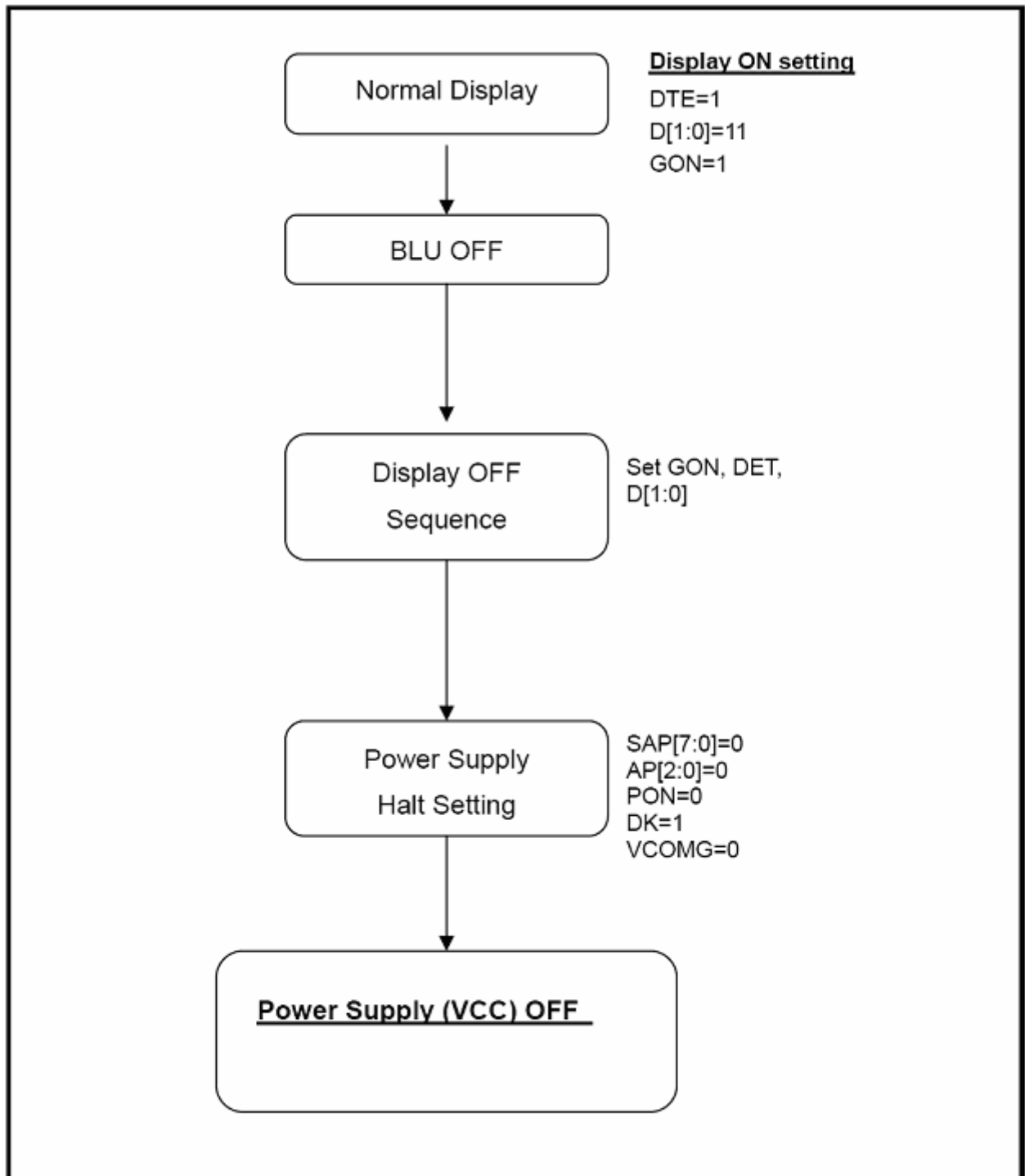



## 6 Optical Characteristics

### 6.1 Optical Specification

Ta=25°C

Item	Symbol	Condition	Min.	Typ.	Max.	Unit	Remark
View Angles	$\theta T$	$CR \cong 10$	60	70	-	Degree	Note 2
	$\theta B$		45	55	-		
	$\theta L$		60	70	-		
	$\theta R$		60	70	-		
Contrast Ratio	CR	$\theta=0^\circ$	400	500	-		Note1 Note3
Response Time	$T_{ON}$	25°C	-	25	40	ms	Note1 Note4
	$T_{OFF}$						
Chromaticity	White	x	Backlight is on	0.245	0.295	0.345	Note5, Note1
		y		0.260	0.310	0.360	
	Red	x		0.555	0.605	0.655	
		y		0.285	0.335	0.385	
	Green	x		0.286	0.336	0.386	
		y		0.566	0.616	0.666	
	Blue	x		0.102	0.152	0.202	
		y		0.027	0.077	0.127	
Uniformity	U		-	80	-	%	Note1 Note6
NTSC			-	60	-	%	Note 5
Luminance	L		200	250	-	cd/m <sup>2</sup>	Note1 Note7

Test Conditions:

- $V_F = 3.2V$ ,  $I_F = 80mA$  (Backlight current), the ambient temperature is 25°C.
- The test systems refer to Note 1 and Note 2.



Note 1: Definition of optical measurement system.

The optical characteristics should be measured in dark room. After 5 minutes operation, the optical properties are measured at the center point of the LCD screen. All input terminals LCD panel must be ground when measuring the center area of the panel.

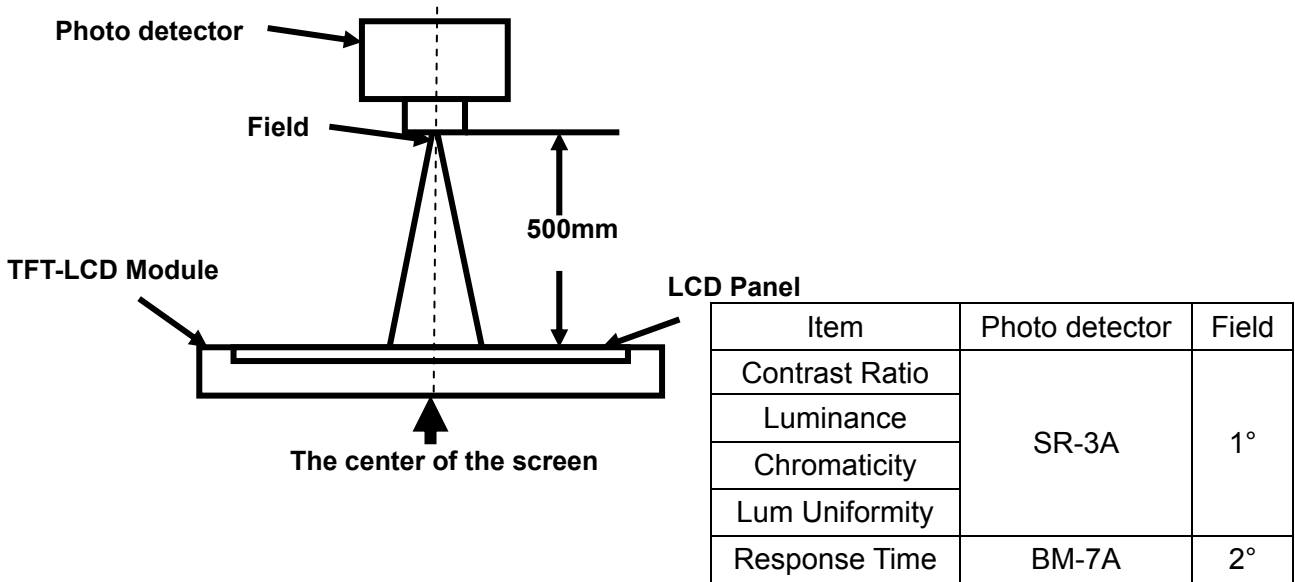

Note 2: Definition of viewing angle range and measurement system.

viewing angle is measured at the center point of the LCD by CONOSCOPE(ergo-80).

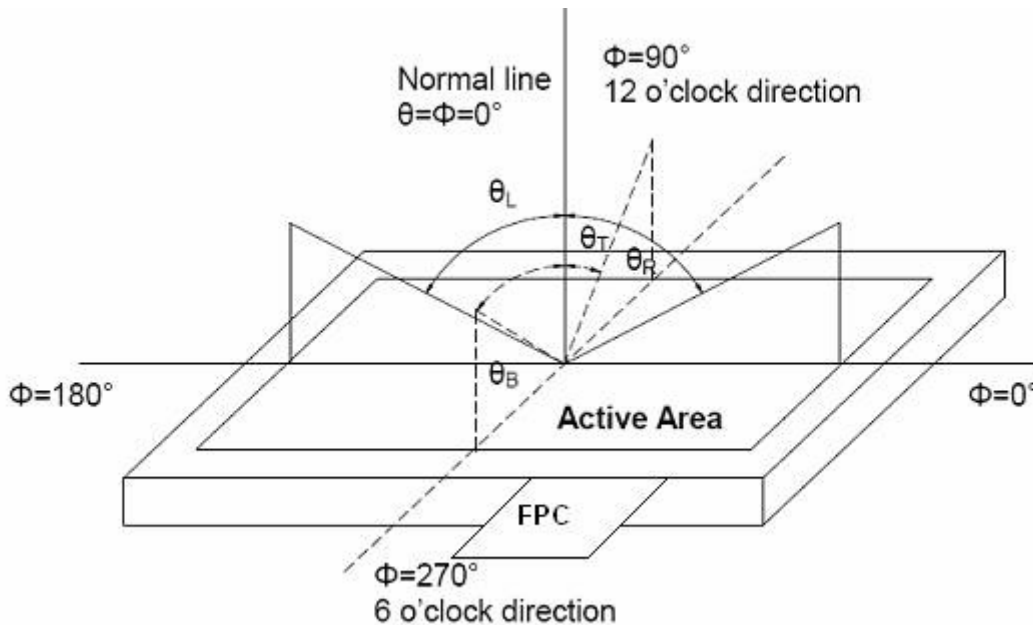

Fig. 1 Definition of viewing angle

The information contained herein is the exclusive property of SHANGHAI TIANMA MICRO-ELECTRONICS Corporation, and shall not be distributed, reproduced, or disclosed in whole or in part without prior written permission of SHANGHAI TIANMA MICRO-ELECTRONICS Corporation.

**Note 3: Definition of contrast ratio**

$$\text{Contrast ratio (CR)} = \frac{\text{Luminance measured when LCD is on the "White" state}}{\text{Luminance measured when LCD is on the "Black" state}}$$

“White state “:The state is that the LCD should be driven by  $V_{\text{white}}$ .

“Black state”: The state is that the LCD should be driven by  $V_{\text{black}}$ .

$V_{\text{white}}$ : To be determined     $V_{\text{black}}$ : To be determined.

**Note 4: Definition of Response time**

The response time is defined as the LCD optical switching time interval between “White” state and “Black” state. Rise time ( $T_{\text{ON}}$ ) is the time between photo detector output intensity changed from 90% to 10%. And fall time ( $T_{\text{OFF}}$ ) is the time between photo detector output intensity changed from 10% to 90%.

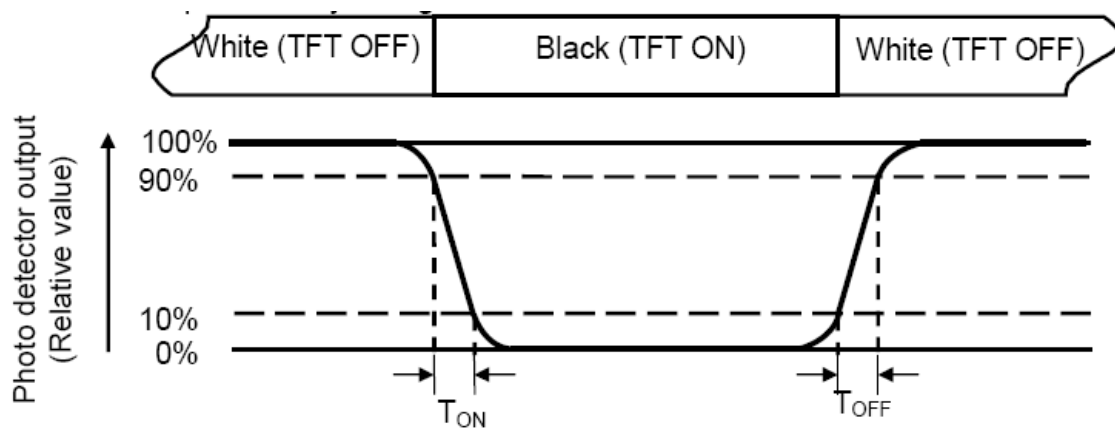
**Note 5: Definition of color chromaticity (CIE1931)**

Color coordinates measured at center point of LCD.

**Note 6: Definition of Luminance Uniformity**

Active area is divided into 9 measuring areas (Refer Fig. 2). Every measuring point is placed at the center of each measuring area.

$$\text{Luminance Uniformity}(U) = L_{\min} / L_{\max}$$

L-----Active area length W----- Active area width

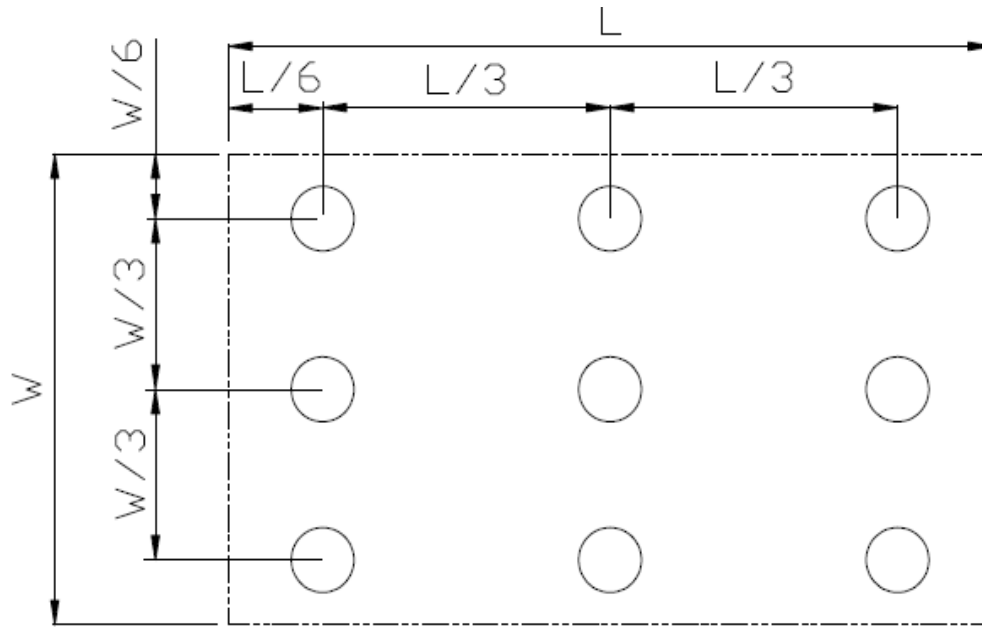

Fig. 2 Definition of uniformity

$L_{\max}$ : The measured maximum luminance of all measurement position.

$L_{\min}$ : The measured minimum luminance of all measurement position.

**Note 7: Definition of Luminance:**

Measure the luminance of white state at center point.



## 7 Environmental / Reliability Tests

No	Test Item	Condition	Remarks
1	High Temperature Operation	Ts=+70°C, 120hrs	Note1 IEC60068-2-2,GB2423.2—89
2	Low Temperature Operation	Ta=-20°C, 120hrs	IEC60068-2-1 GB2423.1—89
3	High Temperature Storage	Ta=+80°C, 120hrs	IEC60068-2-2, GB2423.2—89
4	Low Temperature Storage	Ta=-30°C, 120hrs	IEC60068-2-1 GB2423.1—89
5	High Temperature & High Humidity Storage	Ta=+60°C, 90% RH 120 hours	Note2 IEC60068-2-3, GB/T2423.3—2006
6	Thermal Shock (Non-operation)	-30°C 30 min~+80°C 30 min, Change time:5min, 20 Cycles	Start with cold temperature, End with high temperature, IEC60068-2-14,GB2423.22—87
7	Electro Static Discharge (Operation)	C=150pF, R=330Ω, 5points/panel Air:±8KV, 5times; Contact:±4KV, 5 times; (Environment: 15°C~35°C, 30%~60%, 86Kpa~106Kpa)	IEC61000-4-2 GB/T17626.2—1998
8	Vibration (Non-operation)	Frequency range:10~55Hz, Stroke:1.5mm Sweep:10Hz~55Hz~10Hz 2 hours for each direction of X.Y.Z. (6 hours for total)(Package condition)	IEC60068-2-6 GB/T2423.10—1995
9	Shock (Non-operation)	60G 6ms, ±X,±Y,±Z 3times, for each direction	IEC60068-2-27 GB/T2423.5—1995
10	Package Drop Test	Height:80 cm, 1 corner, 3 edges, 6 surfaces	IEC60068-2-32 GB/T2423.8—1995

Note1: Ts is the temperature of panel's surface.

Note2: Ta is the ambient temperature of sample.





# 8 Mechanical Drawing

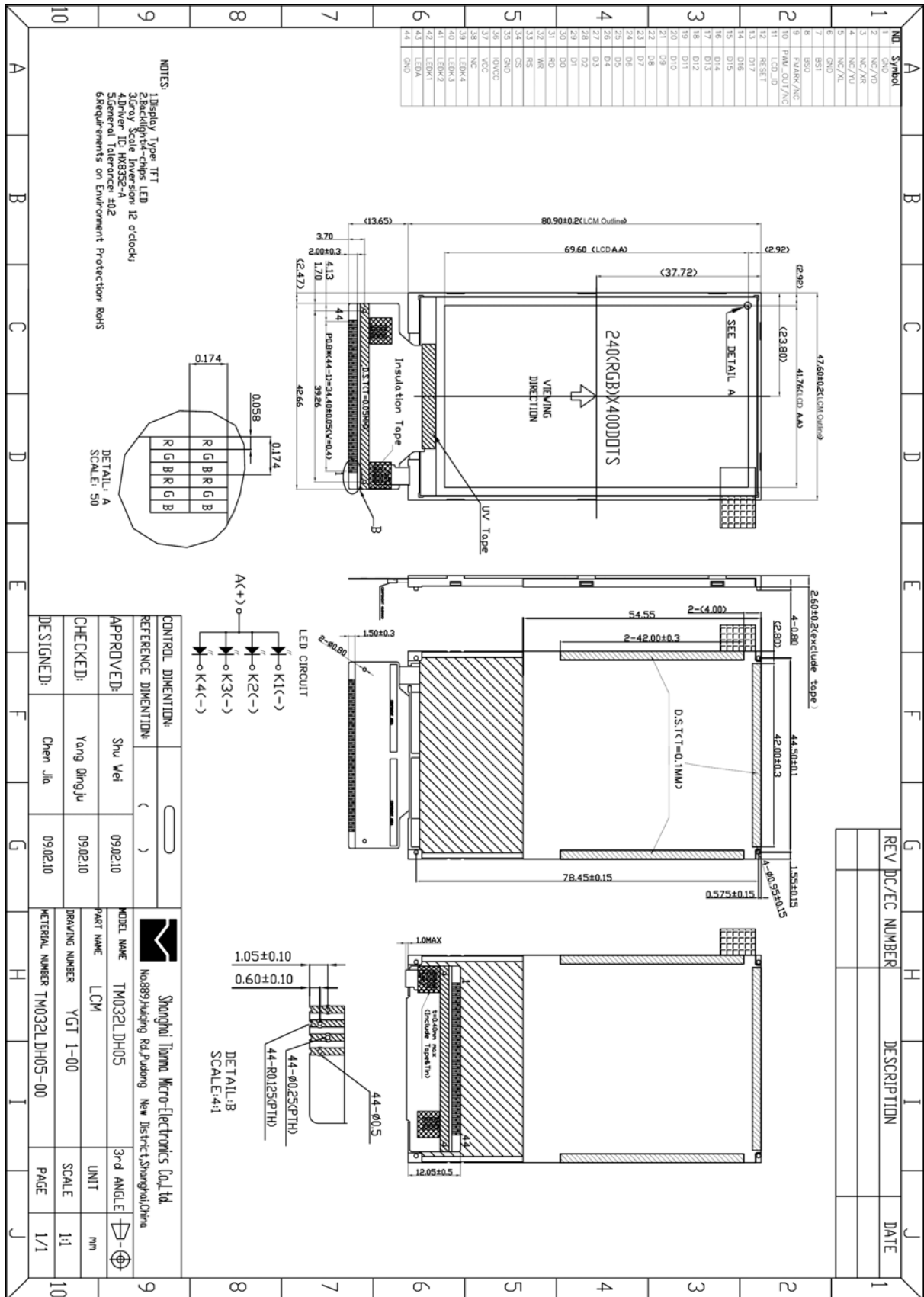

The information contained herein is the exclusive property of SHANGHAI TIANMA MICRO-ELECTRONICS Corporation, and shall not be distributed, reproduced, or disclosed in whole or in part without prior written permission of SHANGHAI TIANMA MICRO-ELECTRONICS Corporation.



## 9 Packing Drawing

TBD



## 10 Precautions for Use of LCD Modules

### 10.1 Handling Precautions

- 10.1.1 The display panel is made of glass. Do not subject it to a mechanical shock by dropping it from a high place, etc.
- 10.1.2 If the display panel is damaged and the liquid crystal substance inside it leaks out, be sure not to get any in your mouth, if the substance comes into contact with your skin or clothes, promptly wash it off using soap and water.
- 10.1.3 Do not apply excessive force to the display surface or the adjoining areas since this may cause the color tone to vary.
- 10.1.4 The polarizer covering the display surface of the LCD module is soft and easily scratched. Handle this polarizer carefully.
- 10.1.5 If the display surface is contaminated, breathe on the surface and gently wipe it with a soft dry cloth. If still not completely clear, moisten cloth with one of the following solvents:
  - Isopropyl alcohol
  - Ethyl alcoholSolvents other than those mentioned above may damage the polarizer. Especially, do not use the following:
  - Water
  - Ketone
  - Aromatic solvents
- 10.1.6 Do not attempt to disassemble the LCD Module.
- 10.1.7 If the logic circuit power is off, do not apply the input signals.
- 10.1.8 To prevent destruction of the elements by static electricity, be careful to maintain an optimum work environment.
  - 10.1.8.1 Be sure to ground the body when handling the LCD Modules.
  - 10.1.8.2 Tools required for assembly, such as soldering irons, must be properly ground.
  - 10.1.8.3 To reduce the amount of static electricity generated, do not conduct assembly and other work under dry conditions.
  - 10.1.8.4 The LCD Module is coated with a film to protect the display surface. Be care when peeling off this protective film since static electricity may be generated.

### 10.2 Storage precautions

- 10.2.1 When storing the LCD modules, avoid exposure to direct sunlight or to the light of fluorescent lamps.
- 10.2.2 The LCD modules should be stored under the storage temperature range. If the LCD modules will be stored for a long time, the recommend condition is:  
Temperature : 0°C ~ 40°C      Relatively humidity: ≤80%
- 10.2.3 The LCD modules should be stored in the room without acid, alkali and harmful gas.

### 10.3 Transportation Precautions:

The LCD modules should be no falling and violent shocking during transportation, and also should avoid excessive press, water, damp and sunshine.