



MODEL NO. : TM050RBH01

ISSUED DATE: 2010-12-16

VERSION : Ver 1.2

- Preliminary Specification
- Final Product Specification

Customer : _____

Approved by	Notes

SHANGHAI TIANMA Confirmed :

Prepared by	Checked by	Approved by

This technical specification is subjected to change without notice



Table of Contents

Table of Contents.....	2
Record of Revision	3
1 General Specifications.....	4
2 Input/Output Terminals.....	5
3 Absolute Maximum Ratings.....	7
4 Electrical Characteristics	8
5 Timing Chart	10
6 Optical Characteristics.....	14
7 Environmental / Reliability Test.....	17
8 Mechanical Drawing	19
9 Packing Drawing.....	21
10 TFT- LCD Module Incoming Inspection Standard.....	22
11 Precautions for Use of LCD Modules	25



1 General Specifications

	Feature	Spec
Display Spec.	Size	5.0 inch
	Resolution	800(RGB)x480
	Interface	RGB 24bits
	Color Depth	16.7M
	Technology Type	a-Si
	Pixel Configuration	R.G.B Vertical Stripe
	Display Mode	TN,NW
	Surface Treatment	AG
	Viewing Direction	12 o'clock
	Gray Scale Inversion Direction	6 o'clock
Mechanical Characteristics	LCM (W x H x D) (mm)	120.70x75.80x3.00
	Active Area(mm)	108.00x64.80
	With /Without TSP	With TSP
	Weight (g)	TBD
	LED Numbers	TBD

Note 1: Viewing direction for best image quality is different from TFT definition. There is a 180 degree shift.

Note 2: Requirements on Environmental Protection: Q/S0002

Note 3: LCM weight tolerance: $\pm 5\%$



2 Input/Output Terminals

2.1 TFT LCD Panel

No	Symbol	I/O	Description	Comment
1	VSS	P	Ground	
2	VSS	P	Ground	
3	VDD	P	Power Supply (+3.3V)	
4	VDD	P	Power Supply	
5	R0	I	Red data(LSB)	
6	R1	I	Red data	
7	R2	I	Red data	
8	R3	I	Red data	
9	R4	I	Red data	
10	R5	I	Red data	
11	R6	I	Red data	
12	R7	I	Red data(MSB)	
13	G0	I	Green data(LSB)	
14	G1	I	Green data	
15	G2	I	Green data	
16	G3	I	Green data	
17	G4	I	Green data	
18	G5	I	Green data	
19	G6	I	Green data	
20	G7	I	Green data(MSB)	
21	B0	I	Blue data(LSB)	
22	B1	I	Blue data	
23	B2	I	Blue data	
24	B3	I	Blue data	
25	B4	I	Blue data	
26	B5	I	Blue data	
27	B6	I	Blue data	
28	B7	I	Blue data(MSB)	
29	VSS	P	Ground (VSS)	
30	PCLK	I	Clock for input data. Data latched at rising edge of this signal.	
31	DISP	I	STBYB="1": display on. STBYB="0": display off .	
32	HSYNC	I	Horizontal signal	
33	VSNC	I	Vertical signal	
No	Symbol	I/O	Description	Comment
34	DE	I	Data enable	
35	SCS	-	NC	

The information contained herein is the exclusive property of SHANGHAI TIANMA MICRO-ELECTRONICS Corporation, and shall not be distributed, reproduced, or disclosed in whole or in part without prior written permission of SHANGHAI TIANMA MICRO-ELECTRONICS Corporation.



36	SCL	-	NC	
37	Y2	I/O	Touch Panel Y(12 Clock Side)	
38	X2	I/O	Touch Panel X(Left Side)	
39	Y1	I/O	Touch Panel Y(6 Clock Side)	
40	X1	I/O	Touch Panel X(Right Side)	
41	SDI	-	NC	
42	LED -	P	Ground(Cathode)	
43	LED +	P	LED Input Terminal (Anode)	
44	LED -	P	Ground(Cathode)	
45	LED +	P	LED Input Terminal (Anode)	

Note1: I/O definition:

I-----Input P----Power O-----Output



3 Absolute Maximum Ratings

3.1 Driving TFT LCD Panel

Ta =25°C

Item	Symbol	MIN	MAX	Unit	Remark
Supply Voltage	VDD	-0.5	5.0	V	
Back Light Forward Current	I _{LED}		25	mA	For each LED
Operating Temperature	T _{OPR}	-20	60	°C	
Storage Temperature	T _{STG}	-30	70	°C	



4 Electrical Characteristics

4.1 Driving TFT LCD Panel

VSS=0V, Ta=25°C

Item	Symbol	MIN	TYP	MAX	Unit	Remark
Supply Voltage	VDD	3.0	3.3	3.6	V	
Input Signal Voltage	Low Level	V_{IL}	0	--	$0.3 \times VDD$	V
	High Level	V_{IH}	$0.7 \times VDD$	--	VDD	V
Output Voltage Signal	Low Level	V_{OL}	--	--	VSS+0.4	V
	High Level	V_{OH}	$VDD-0.4$	--	--	V
(Panel+LSI) Power Consumption	Black Mode (60Hz)		TBD			mW
	Standby Mode		TBD			mW

4.2 Backlight Unit

Ta=25°C

Item	Symbol	MIN	TYP	MAX	Unit	Remark
Forward Current	I_F	--	20	25	mA	For each LED
Forward Current Voltage	V_F	--	19.2	--	V	
Backlight Power Consumption	W_{BL}	--	1152	--	mW	

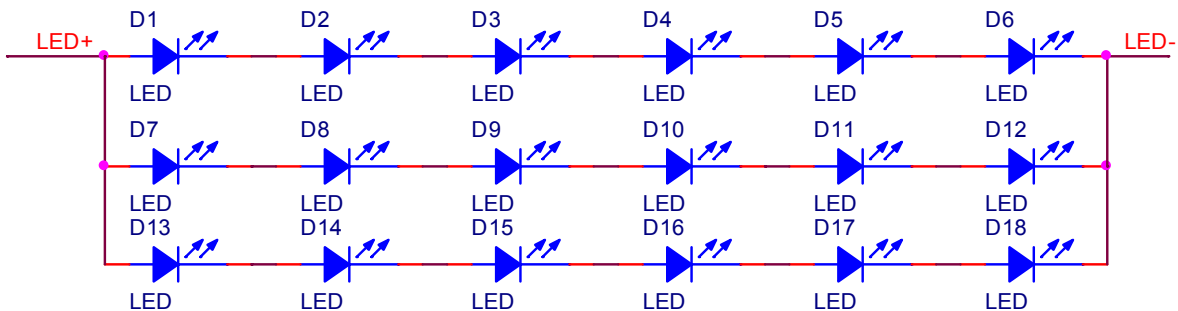



4.3 Block Diagram

LCD module diagram

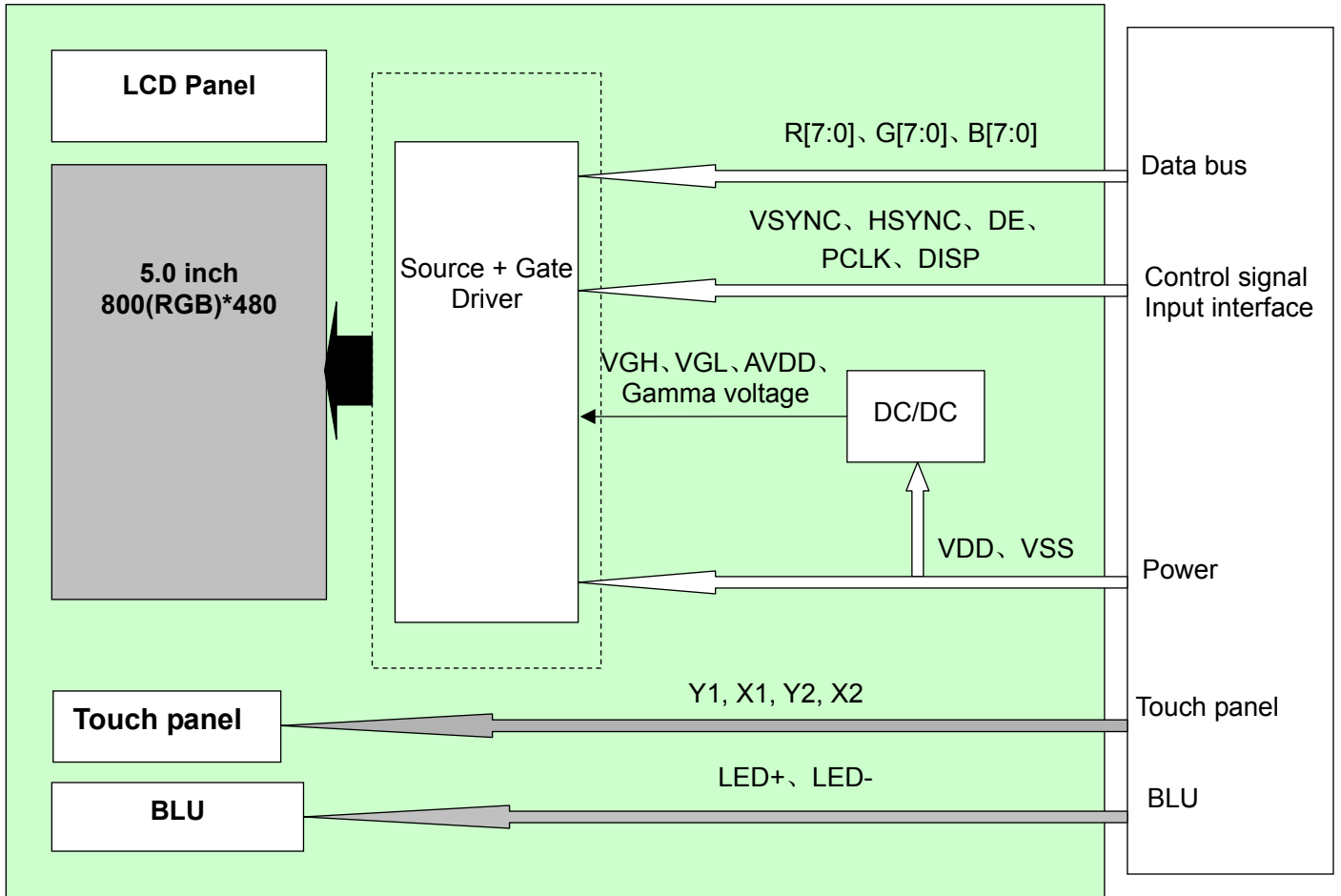



5 Timing Chart

5.1 Input Clock and Data Timing Diagram

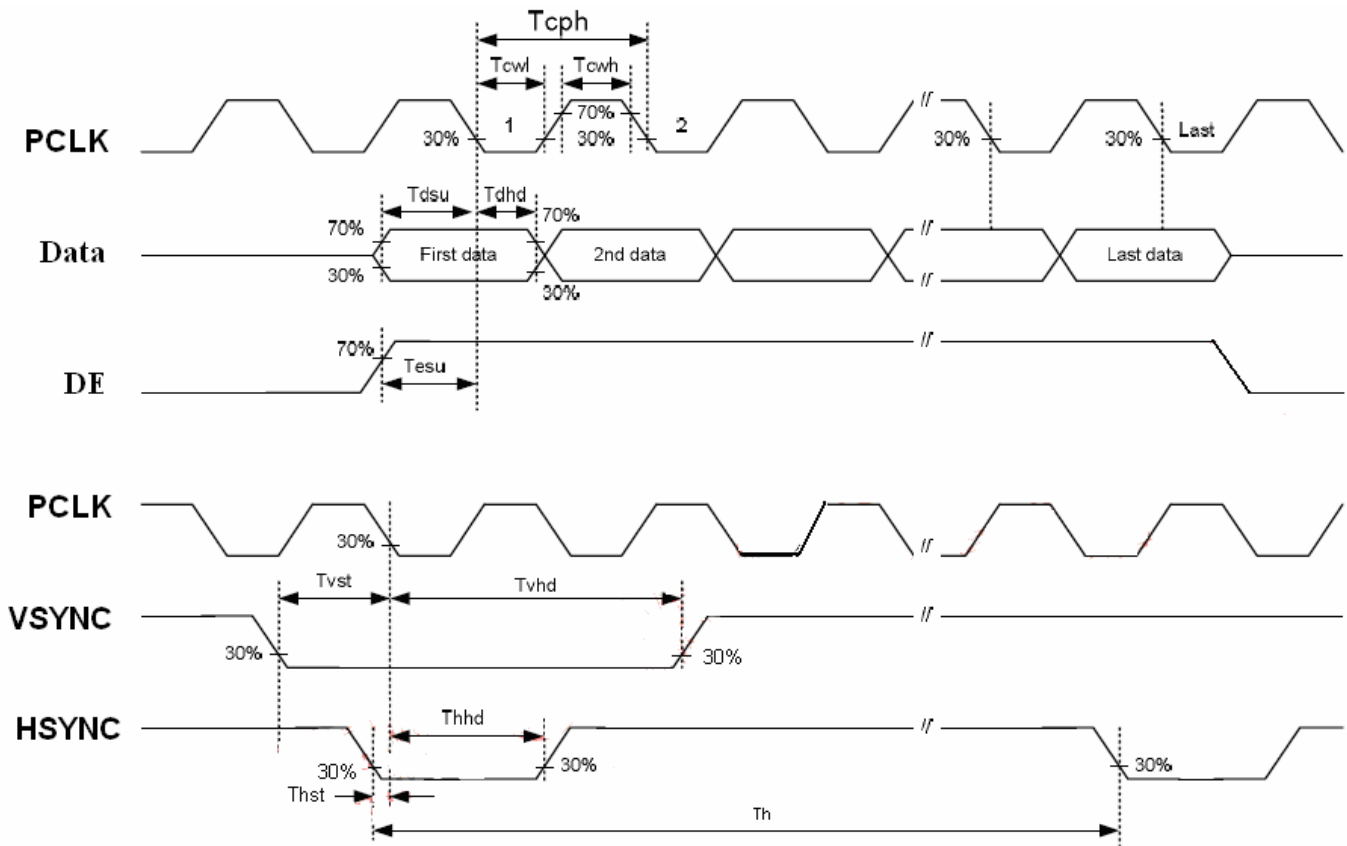

5.2 Timing Parameters

Normal Write Mode

VDD=3.3V Ta=25°C

Parameter	Symbol	Min	Typ	Max	Unit	Remark
HSYNC Setup Time	T_{hst}	8	--	--	ns	
HSYNC Hold Time	T_{hhd}	8	--	--	ns	
VSYNC Setup Time	T_{vst}	8	--	--	ns	
VSYNC Hold Time	T_{vhd}	8	--	--	ns	
Data Setup Time	T_{dsu}	8	--	--	ns	
Data Hold Time	T_{dhd}	8	--	--	ns	
DE Setup Time	T_{esu}	8	--	--	ns	
DE Hold Time	T_{ehd}	8	--	--	ns	
PCLK Cycle Time	T_{cph}	20	--	--	ns	
PCLK Pulse Width	T_{cwh}	40	50	60	%	
Output stable time	T_{sst}	--	-	6	us	
VDD Power ON Slew rate	T_{por}		--	20	ms	
RSTB pulse width	T_{rst}	10	--	--	us	

The information contained herein is the exclusive property of SHANGHAI TIANMA MICRO-ELECTRONICS Corporation, and shall not be distributed, reproduced, or disclosed in whole or in part without prior written permission of SHANGHAI TIANMA MICRO-ELECTRONICS Corporation.



5.3 Data Input format

5.3.1 Horizontal Input Timing Diagram

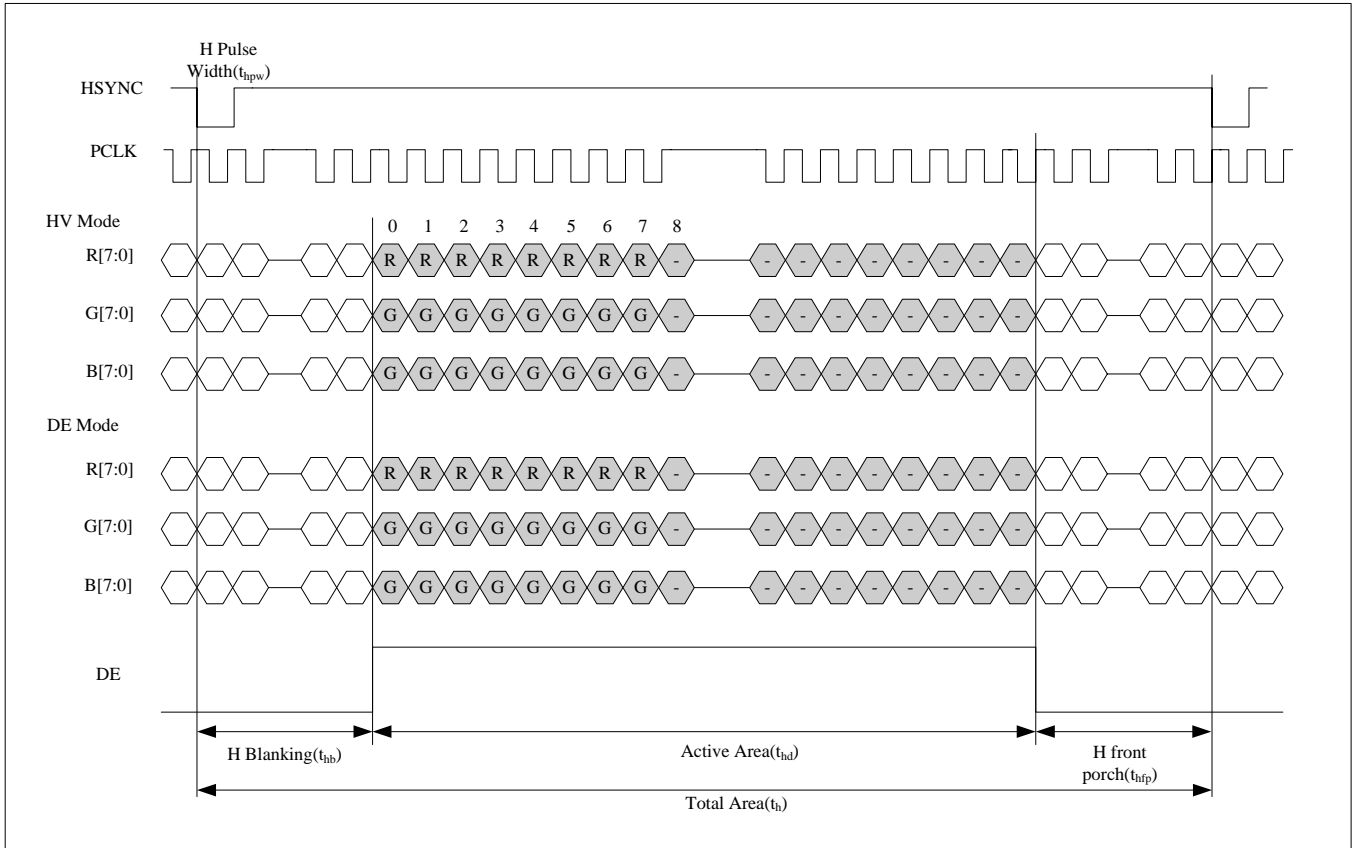

5.3.2 Vertical Input Timing Diagram

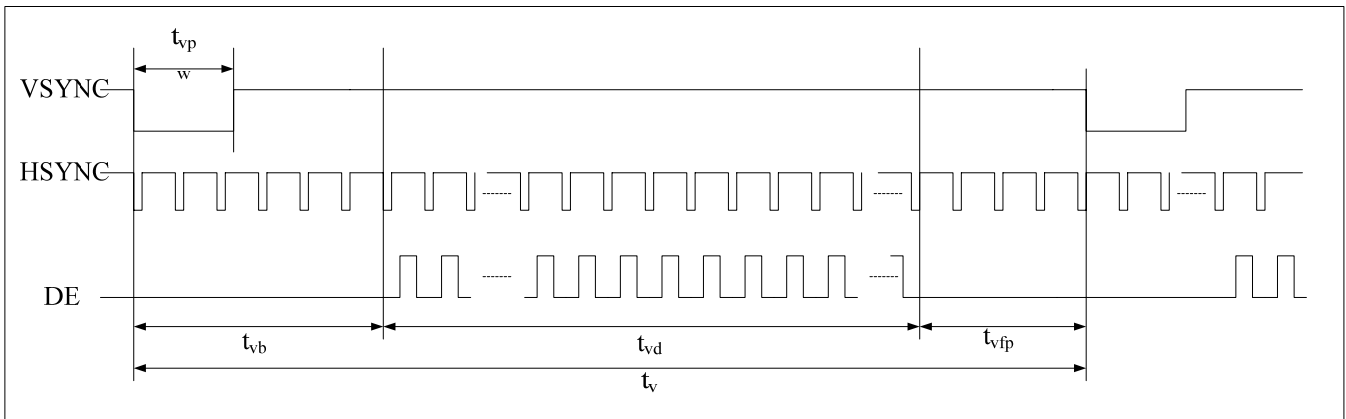



5.3.3 Parameter Setting Of Timing

Parameter	Symbol	Spec.			Unit
		Min.	Typ.	Max.	
Horizontal display area	t_{hd}		800		PCLK
PCLK frequency (60Hz)	f_{clk}	--	30	50	MHZ
One Horizontal Line	t_h	889	928	1143	PCLK
HSYNC pulse width	t_{hpw}	1	48	255	PCLK
HSYNC blanking	t_{hb}		88		PCLK
HSYNC front porch	t_{hfp}	1	40	255	PCLK
Vertical display area	t_{vd}		480		T_H
VSYNC period time	t_v	513	525	767	T_H
VSYNC pulse width	t_{vpw}	3	3	255	T_H
VSYNC Blanking(tvb)	t_{vb}		32		T_H
VSYNC Front porch (tvfp)	t_{vfp}	1	13	255	T_H



5.4 Power ON Sequence

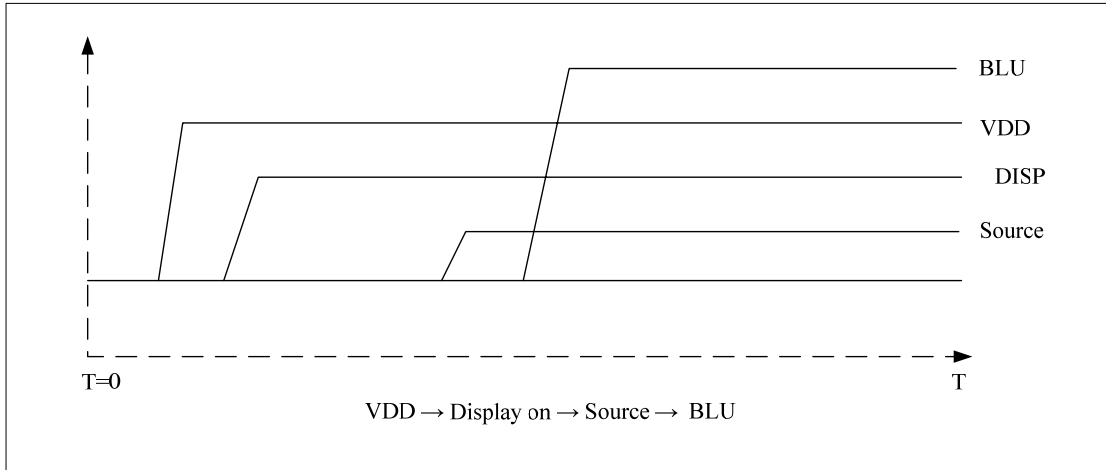

5.5 Power Off Sequence

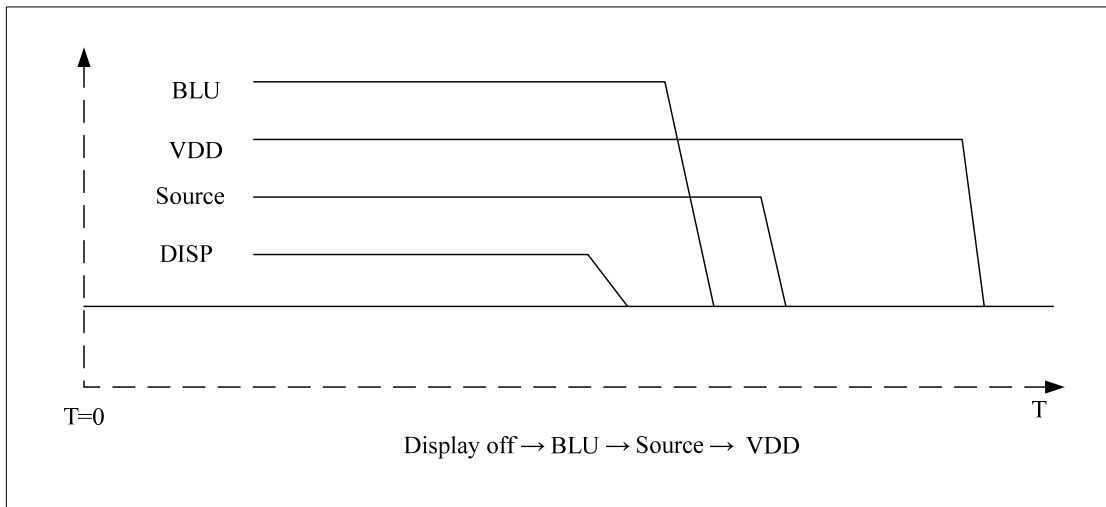

5.6 Power ON/Off Sequence

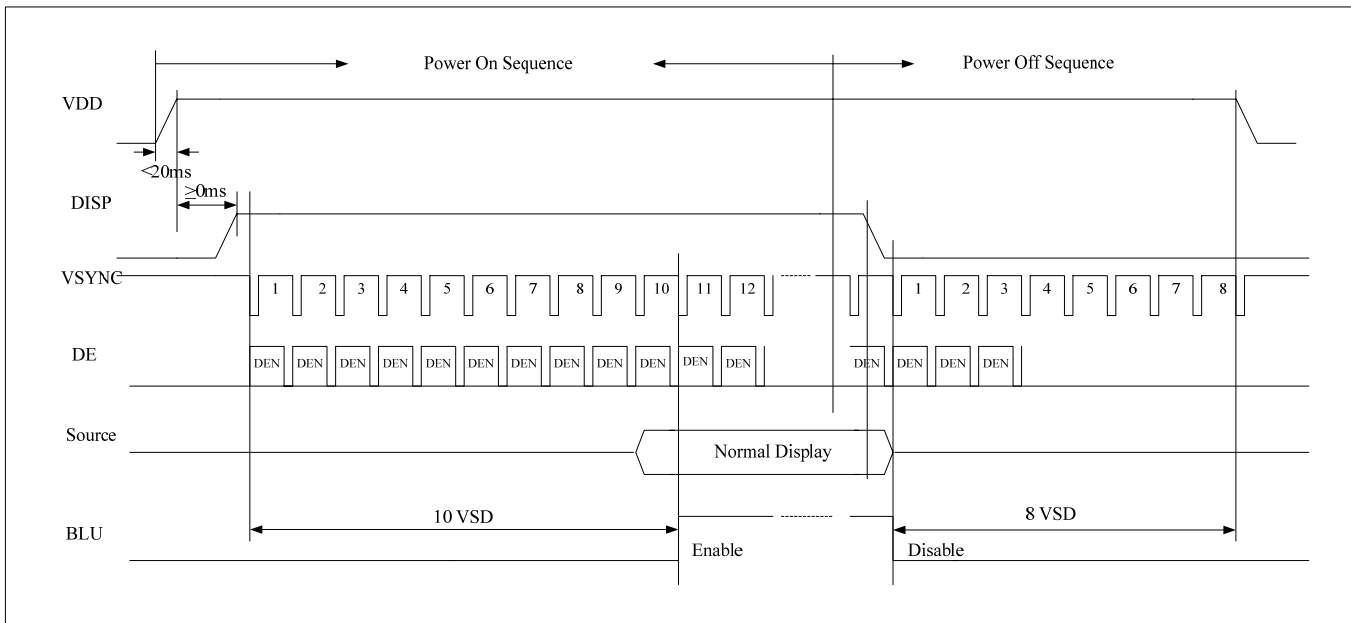

The information contained herein is the exclusive property of SHANGHAI TIANMA MICRO-ELECTRONICS Corporation, and shall not be distributed, reproduced, or disclosed in whole or in part without prior written permission of SHANGHAI TIANMA MICRO-ELECTRONICS Corporation.



6 Optical Characteristics

Ta=25°C

Item	Symbol	Condition	Min	Typ	Max	Unit	Remark
View Angles	θT	$CR \geq 10$	40	50	--	Degree	Note2,3
	θB		60	70	--		
	θL		60	70	--		
	θR		60	70	--		
Contrast Ratio	CR	$\theta=0^\circ$	500	600	--		Note 3
Response Time	T_{ON}	25°C	--	20	30	ms	Note 4
	T_{OFF}						
Chromaticity	White	Backlight is on	x	0.270	0.320	0.370	Note 1,5
			y	0.290	0.340	0.390	
	Red		x	0.540	0.590	0.640	Note 1,5
			y	0.300	0.350	0.400	
	Green		x	0.298	0.348	0.398	Note 1,5
			y	0.530	0.580	0.630	
	Blue		x	0.100	0.150	0.200	Note 1,5
			y	0.050	0.100	0.150	
Uniformity	U		75	80	--	%	Note 6
NTSC			--	50	--	%	Note 5
Luminance	L		250	300	--	cd/m ²	Note 7

Test Conditions:

1. $I_F=22$ mA, and the ambient temperature is 25°C.
2. The test systems refer to Note 1 and Note 2.



Note 1: Definition of optical measurement system.

The optical characteristics should be measured in dark room. After 5 Minutes operation, the optical properties are measured at the center point of the LCD screen. All input terminals LCD panel must be ground when measuring the center area of the panel.

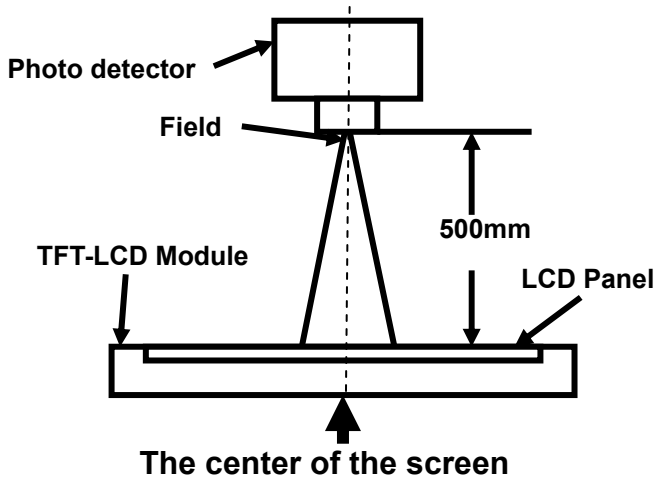

Item	Photo detector	Field
Contrast Ratio	SR-3A	1°
Luminance		
Chromaticity		
Lum Uniformity		
Response Time	BM-7A	2°

Note 2:

Definition of viewing angle range and measurement system.

viewing angle is measured at the center point of the LCD by CONOSCOPE(ergo-80).

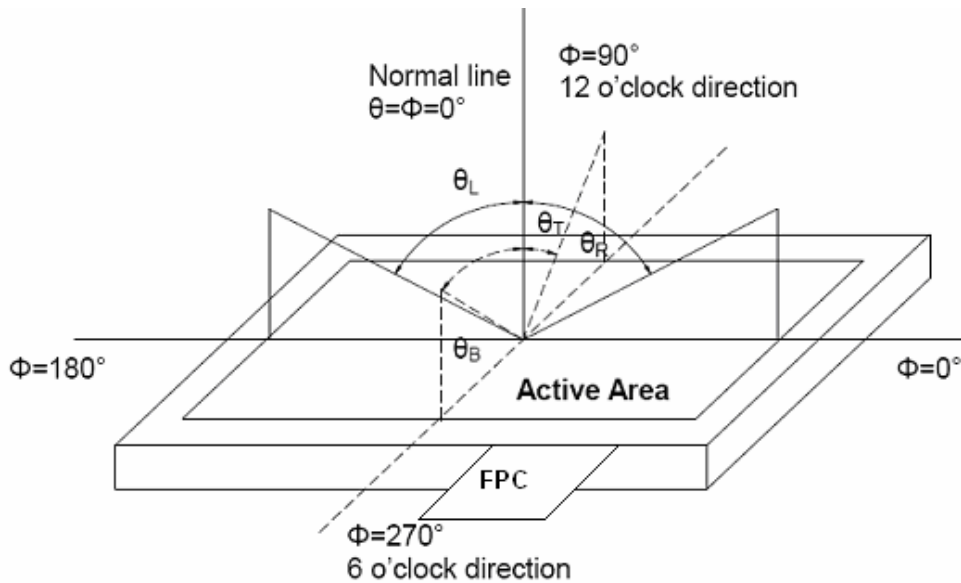

Note 3: Definition of contrast ratio

$$\text{Contrast ratio (CR)} = \frac{\text{Luminance measured when LCD is on the "White" state}}{\text{Luminance measured when LCD is on the "Black" state}}$$

“White state “: The state is that the LCD should drive by V_{white} .

“Black state”: The state is that the LCD should drive by V_{black} .

V_{white} : To be determined V_{black} : To be determined.

Note 4: Definition of Response time



The response time is defined as the LCD optical switching time interval between "White" state and "Black" state. Rise time (T_{ON}) is the time between photo detector output intensity changed from 90% to 10%. And fall time (T_{OFF}) is the time between photo detector output intensity changed from 10% to 90%.

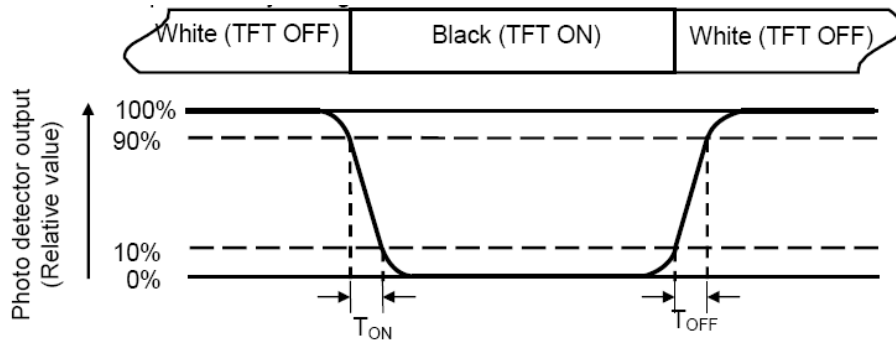

Note 5: Definition of color chromaticity (CIE1931)

Color coordinates measured at center point of LCD.

Note 6: Definition of Luminance Uniformity

Active area is divided into 9 measuring areas (Refer Fig. 2). Every measuring point is placed at the center of each measuring area.

$$\text{Luminance Uniformity (U)} = L_{\min} / L_{\max}$$

L-----Active area length W----- Active area width

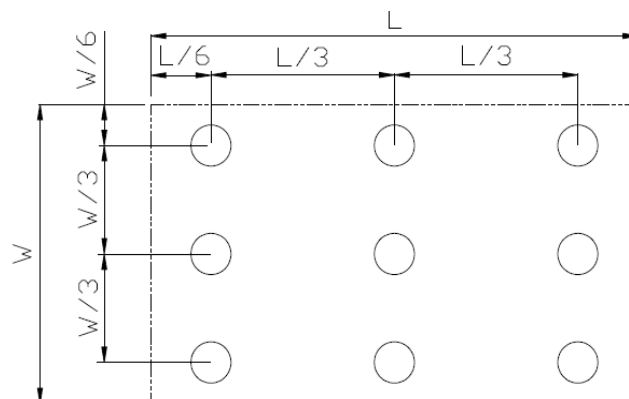

L_{\max} : The measured Maximum luminance of all measurement position.

L_{\min} : The measured Minimum luminance of all measurement position.

Note 7: Definition of Luminance:

Measure the luminance of white state at center point.

**7 Environmental / Reliability Test**

No	Test Item	Condition	Remark
1	High Temperature Operation	Ts=+60°C, 240hrs	Note1 IEC60068-2-2,GB2423.2—89
2	Low Temperature Operation	Ta=-20°C, 240hrs	IEC60068-2-1 GB2423.1—89
3	High Temperature Storage	Ta=+70°C, 240hrs	IEC60068-2-2, GB2423.2—89
4	Low Temperature Storage	Ta=-30°C, 240hrs	IEC60068-2-1 GB2423.1—89
5	High Temperature & High Humidity Storage	Ta=+60°C, 90% RH 240 hours	Note2 IEC60068-2-3, GB/T2423.3—2006
6	Thermal Shock (Non-operation)	-30°C 30 min~+70°C 30 min, Change time:5min, 20 Cycles	Start with cold temperature, End with high temperature, IEC60068-2-14,GB2423.22—87
7	Electro Static Discharge (Operation)	C=150pF, R=330Ω, 5points/panel Air:±8KV, 5times; Contact:±4KV, 5 times; (Environment: 15°C~35°C, 30%~60%, 86Kpa~106Kpa)	IEC61000-4-2 GB/T17626.2—1998
8	Vibration (Non-operation)	Frequency range:10~55Hz, Stroke:1.5mm Sweep:10Hz~55Hz~10Hz 2 hours for each direction of X.Y.Z. (6 hours for total)(Package condition)	IEC60068-2-6 GB/T2423.10—1995
9	Shock (Non-operation)	60G 6ms, ±X,±Y,±Z 3times, for each direction	IEC60068-2-27 GB/T2423.5—1995
10	Package Drop Test	Height:80 cm, 1 corner, 3 edges, 6 surfaces	IEC60068-2-32 GB/T2423.8—1995
11	Baseline Function Test	Room Temp 72Hr	Note 3
12	Operating Temp & Humidity Test	Temp -20°C - +60°C, Humi 0 - 90% RH, 102 Hr	Note 3
13	Storage Test	Temp -40°C - +75°C, Humi 0 - 90% RH, 86 Hr	Note 3
14	Thermal shock Test	-20°C - +60°C, 10 cycle -40°C - +75°C, 10 cycle	Note 3
15	Image Sticking	Room Temp, 24 Hr	Note 4

Note1: Ts is the temperature of panel's surface.

Note2: Ta is the ambient temperature of samples.

The information contained herein is the exclusive property of SHANGHAI TIANMA MICRO-ELECTRONICS Corporation, and shall not be distributed, reproduced, or disclosed in whole or in part without prior written permission of SHANGHAI TIANMA MICRO-ELECTRONICS Corporation.



Note3: The conditions is requested by MITAC.

Note4: Image Sticking Bum In Pattern is the following Cross pattern. And check patterns are Full Screen White, Red, Blue, Green and Black Pattern.

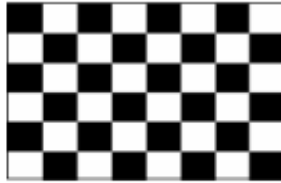

Cross Pattern

Judgment:

Main LCD should work under the normal condition.

After the temperature and humidity test, the luminance and CR (Contrast Ratio) should not be changed over 50% compared wi



8 Mechanical Drawing

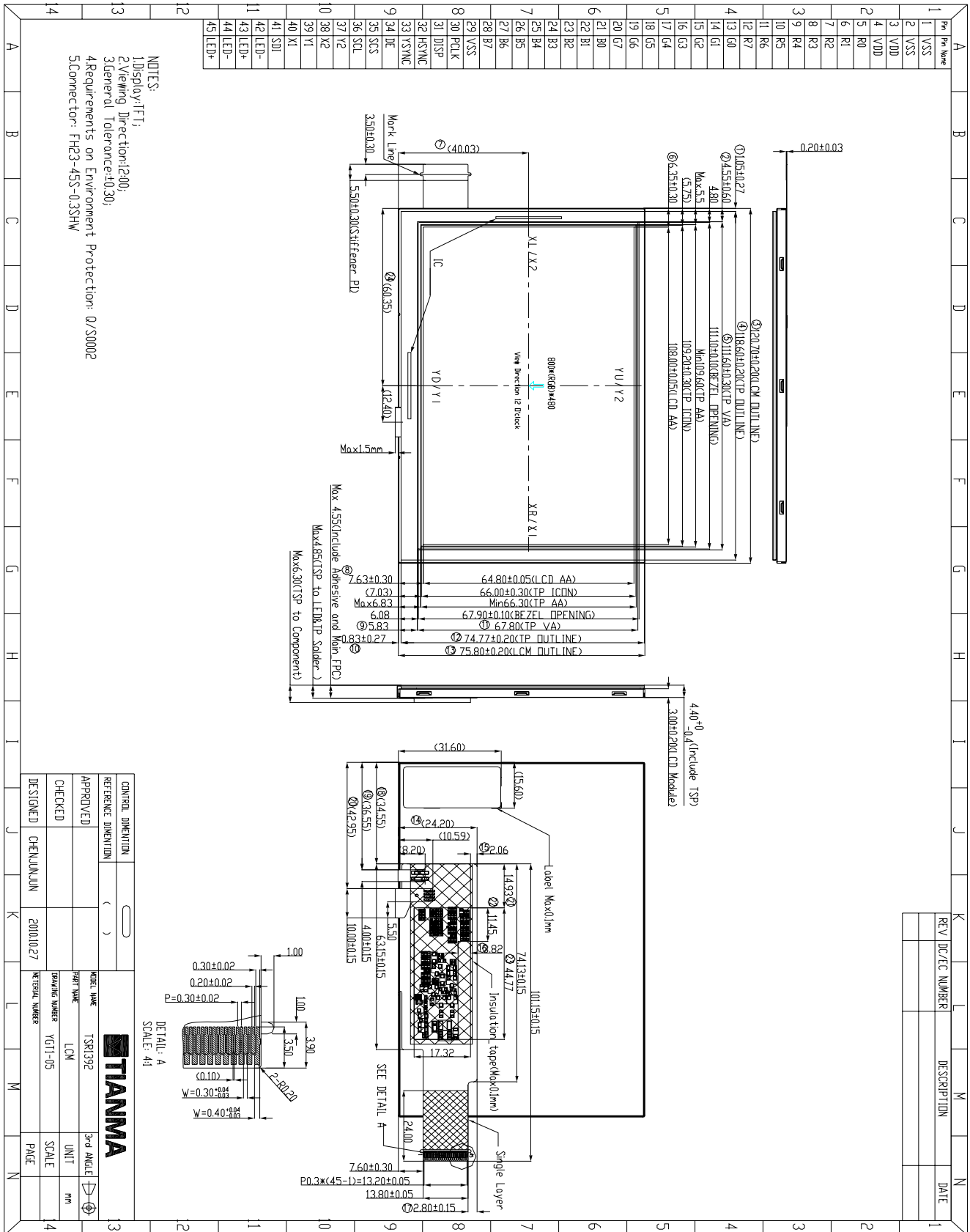

The information contained herein is the exclusive property of SHANGHAI TIANMA MICRO-ELECTRONICS Corporation, and shall not be distributed, reproduced, or disclosed in whole or in part without prior written permission of SHANGHAI TIANMA MICRO-ELECTRONICS Corporation.



结构注意事项

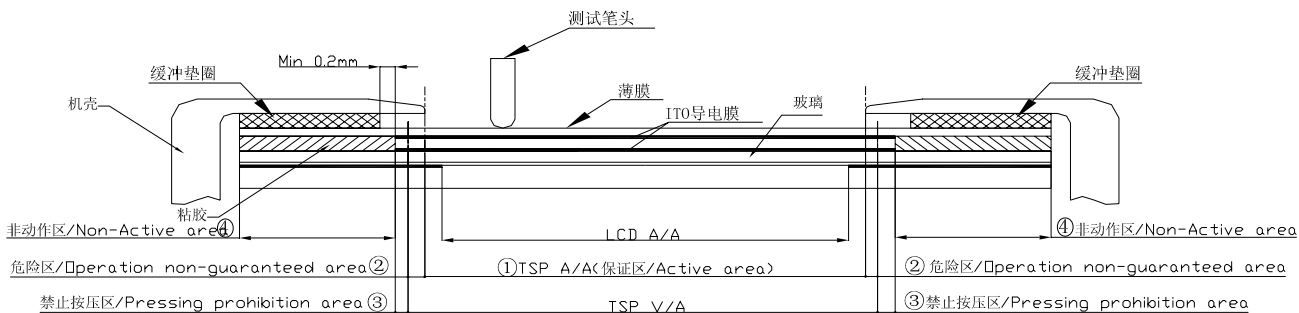

说明:

- ①区域: 动作区此区域按压时触摸屏正常工作。
- ②区域: 危险区
按压此区域触摸屏不能正常工作, 若对此区域做打点、划线测试, 将损坏产品, 导致产品寿命下降, 此区域大约是动作区外侧0.5~1mm。
- ③区域: 禁止按压区
按压此区域会严重损伤内部导电层, 使触摸屏的功能严重破坏。
- ④区域: 非动作区
按压此区域触摸屏不工作。

2、敏感区的处理:

- (1) 区域②、③为敏感区, 由于该区域在产品上下导电面之间存在间隙, 按压此处时ITO导电膜受压产生较大变形, 引起ITO导电膜断裂, 从而使触摸屏丧失功能。故使用触摸屏产品时, 一定要充分考虑敏感区的尺寸及外壳的构造, 必须避免最终的用户使用时触及到此区域。
- (2) 组装触摸屏时, 必须在产品表面四周加上一缓冲垫圈, 再装外壳。垫圈应落在双面胶上, 且不能超出双面胶范围。
- (3) 若外壳设计比动作区大时, 最终用户有可能触及到敏感区而损伤产品。
- (4) 若外壳设计为比动作区小时, 由于外壳四周完全遮盖了敏感区, 因此当沿屏边缘划动时, 不会造成ITO层的损伤, 但是因为外壳伸进了动作区, 因此垫圈的厚度就显得很重要, 太厚, 外壳与膜表面之间的间隙太大, 影响产品的外观, 太薄, 外壳直接压在膜表面上, 会造成短路, 最好外壳与膜表面之间保持在0.2~0.3mm之间。

建议尺寸

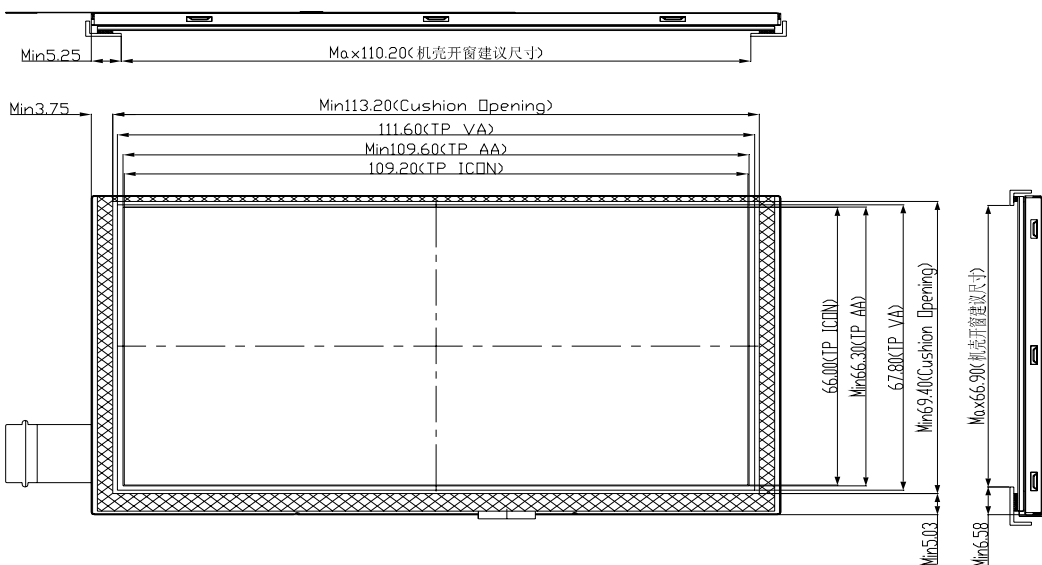

The information contained herein is the exclusive property of SHANGHAI TIANMA MICRO-ELECTRONICS Corporation, and shall not be distributed, reproduced, or disclosed in whole or in part without prior written permission of SHANGHAI TIANMA MICRO-ELECTRONICS Corporation.



9 Packing Drawing

TBD



10 TFT- LCD Module Incoming Inspection Standard

10.1 Scope

The incoming inspection standards shall be applied to TFT-LCD Modules (hereinafter called "Modules") that supplied by Shanghai Tianma Micro-Electronics Corporation.

10.2 Incoming Inspection

The customer shall inspect the modules within twenty calendar days of the delivery date(the "inspection period)at its own cost. The result of the inspection(acceptance or rejection)shall be recorded in writing, and a copy of this writing will be promptly sent to the seller, If the results of the inspecting from buyer does not send to the seller within twenty calendar days of the delivery date. The modules shall be regards as acceptance.

Should the customer fail to notify the seller within the inspection period, the buyer's right to reject the modules. Shall be lapsed and the modules shall be deemed to have been accepted by the buyer.

10.3 Inspection Sampling Method

Lot size: Quantity per shipment lot per model

Sampling type: Normal inspection, Single sampling

Inspection level: II

Sampling table: MIL-STD-105D

Acceptable quality level (AQL)

Major defect: AQL=0.65

Minor defect: AQL=1.00

10.4 Inspection Conditions

10.4.1 ambient conditions:

- Temperature: Room temperature $25\pm 5^{\circ}\text{C}$
- Humidity: $(60\pm 10)\% \text{RH}$
- Illumination: Single fluorescent lamp non-directive (1000 to 1200 Lux)

10.4.2 The viewing distance between the LCD and the inspector's eyes shall be at least $30\pm 5 \text{ cm}$.

10.4.3 Viewing Angle: U/D: $45^{\circ}/45^{\circ}$, L/R: $45^{\circ}/45^{\circ}$

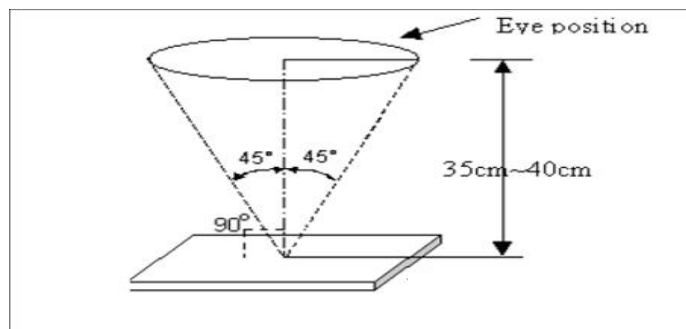

10.5 Inspection Criteria

Defects are classified as major defects and minor defects according to the degree of defectiveness defined herein.



Major defect

Item	Inspection Standard
All Functional Defects	1) No display 2) Display abnormally 3) Short circuit 4) line defect
Missing	Missing function component
Crack	Glass Crack

Minor defect

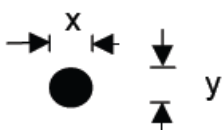
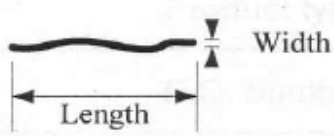
No	Item	Inspection Standard	
1	Spot Defect (Including black spot and white spot)	$\varphi = (x+y) / 2$  <p>For black/white spot is defined</p>	
		Size φ (mm)	Acceptable Quantity
		$\varphi \leq 0.20$	Ignore
		$0.20 < \varphi \leq 0.30$	2
		$0.30 < \varphi \leq 0.40$	1
		$0.40 < \varphi$	Not allowed
2	Line Defect (Including black line, white line and scratch)	 <p>Define:</p>	
		Width(mm) Length(mm)	Acceptable Quantity
		$W \leq 0.03$	Ignore
		$0.03 < W \leq 0.1$ $0.8 < L \leq 2.0$	2
		$0.1 < W$ or $L > 2.0$	Not allowed
3	Polarizer Dent/Bubble	Size φ (mm)	Acceptable Quantity
		$\varphi \leq 0.1$	Ignore
		$0.1 < \varphi \leq 0.3$	2
		$0.3 < \varphi$	0

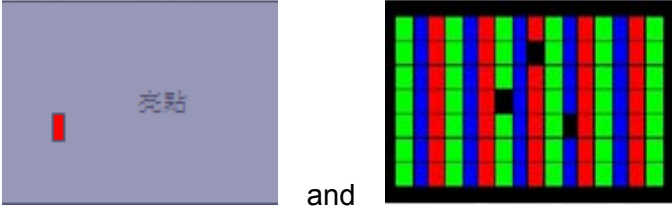

4	Electrical Dot Defect	Bright and black dot define:	
			
		Inspection pattern: Full white、 Full black、 Red、 green and blue screens	
		Item	Acceptable Quantity
		Black dot defect	2
Bright dot defect	1		
Total Dot	2		
5	Newton Ring	Sizeφ(mm)	Acceptable Quantity
		D <15mm	1

Note1: Dot defect is defined as the defective area of the dot area is larger than 50% of the dot area.

Note2: The distance between two bright dot defects (red, green, blue, and white) should be larger than 10mm.

Note3: The distance between black dot defects or black and bright dot defects should be more than 5mm apart.

Note4: The definitions of the inner display area and outer display area

I: Inner display area O: Outer display area

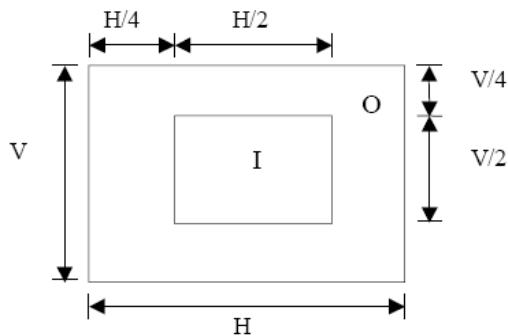

Note5: Polarizer bubble is defined as the bubble appears on active display area. The defect of polarizer bubble shall be ignored if the polarizer bubble appears on the outside of active display area.

10.6 Mechanics specification

As for the outside dimension, weight of the modules, please refer to product specification for more details



11 Precautions for Use of LCD Modules

11.1 Handling Precautions

11.1.1 The display panel is made of glass. Do not subject it to a mechanical shock by dropping it from a high place, etc.

11.1.2 If the display panel is damaged and the liquid crystal substance inside it leaks out, be sure not to get any in your mouth, if the substance comes into contact with your skin or clothes, promptly wash it off using soap and water.

11.1.3 Do not apply excessive force to the display surface or the adjoining areas since this may cause the color tone to vary.

11.1.4 The polarizer covering the display surface of the LCD module is soft and easily scratched. Handle this polarizer carefully.

11.1.5 If the display surface is contaminated, breathe on the surface and gently wipe it with a soft dry cloth. If still not completely clear, moisten cloth with one of the following solvents:

- Isopropyl alcohol
- Ethyl alcohol

Solvents other than those mentioned above may damage the polarizer. Especially, do not use the following:

- Water
- Ketone
- Aromatic solvents

11.1.6 Do not attempt to disassemble the LCD Module.

11.1.7 If the logic circuit power is off, do not apply the input signals.

11.1.8 To prevent destruction of the elements by static electricity, be careful to maintain an optimum work environment.

10.1.8.1 Be sure to ground the body when handling the LCD Modules.

10.1.8.2 Tools required for assembly, such as soldering irons, must be properly ground.

10.1.8.3 To reduce the amount of static electricity generated, do not conduct assembly and other work under dry conditions.

10.1.8.4 The LCD Module is coated with a film to protect the display surface. Be care when peeling off this protective film since static electricity may be generated.

11.2 Storage precautions

11.2.1 When storing the LCD modules, avoid exposure to direct sunlight or to the light of fluorescent lamps.

11.2.2 The LCD modules should be stored under the storage temperature range. If the LCD modules will be stored for a long time, the recommend condition is:

Temperature : 0°C ~ 40°C Relatively humidity: ≤80%

11.2.3 The LCD modules should be stored in the room without acid, alkali and harmful gas.

11.3 Transportation Precautions

11.3.1 The LCD modules should be no falling and violent shocking during transportation, and also should avoid excessive press, water, damp and sunshine.