

SPECIFICATION FOR TFT LCD MODULE

MODEL NO:	TM070RBZ17
CUSTOMER:	
CUSTOMER P/N.	
VERSION	V0.0
CUSTOMER APPROVED	

Preliminary Specification

Final Specification

PREPARED	CHECKED	VERIFIED BY QA DEPT	VERIFIED BY R&D DEPT

TIANMA MICRO-ELECTRONICS CO., LTD

**Address: 8F, 64th Building, Jinlong, Majialong Industrial Area, Nanshan District, Shenzhen,
China** **Tel: +86-755-2609-4288** **Fax: +86-755-8622-5774** **+86-755-8622-5772**

REVISION RECORD

Date	Rev.No.	Page	Revision Items	Prepared
2011.09.06	V0.0		The first release	Ye Qifei

CONTENTS

	Page
1.General Specifications-----	1
2. Outline Drawing-----	2
3. Circuit Block Diagram-----	3
4. Absolute Maximum Ratings-----	4
5. Electrical Specifications and Instruction Code-----	5
6. Optical Characteristics-----	10
7. Reliability Test Items and Criteria-----	14
8 Quality level-----	16
9. Precautions for Use of LCD Modules-----	21

1.General Specifications

TM070RBZ17 is a color active matrix LCD module incorporating amorphous silicon TFT (Thin Film Transistor). This product is composed of a color TFT-LCD Panel, driver ICs, backlight unit and 4 lines resistor touch panel. The 7.0" display area contains 800RGB x 480 pixels and can display up to 262K colors.

- ◆ Requirements on environmental protection: RoHS.

Item	Contents	Unit	Note
LCD Type	TFT	-	
Display Color	262K		1
Viewing Direction	12:00	O'Clock	
Active Area(W×H)	154.08x85.92	mm	
Number of Dots	800(RGB)×480	mm	
Dot Pitch(W×H)	0.1926x0.1790	mm	
Controller	HX8264+HX8664	-	
VCI	3.3	V	
DVDD	3.3	V	
Outline Dimensions	Refer to outline drawing on next page		
Backlight	21-LEDs (white)	-	
Weight	TBD	g	
Interface	Digital 18-bits RGB	-	
Polarizer Mode	Transmissive/Positive	-	

Note 1: Color tune is slightly changed by temperature and driving voltage.

Note 2: Requirements on Environmental Protection:RoHS

2. Outline Drawing

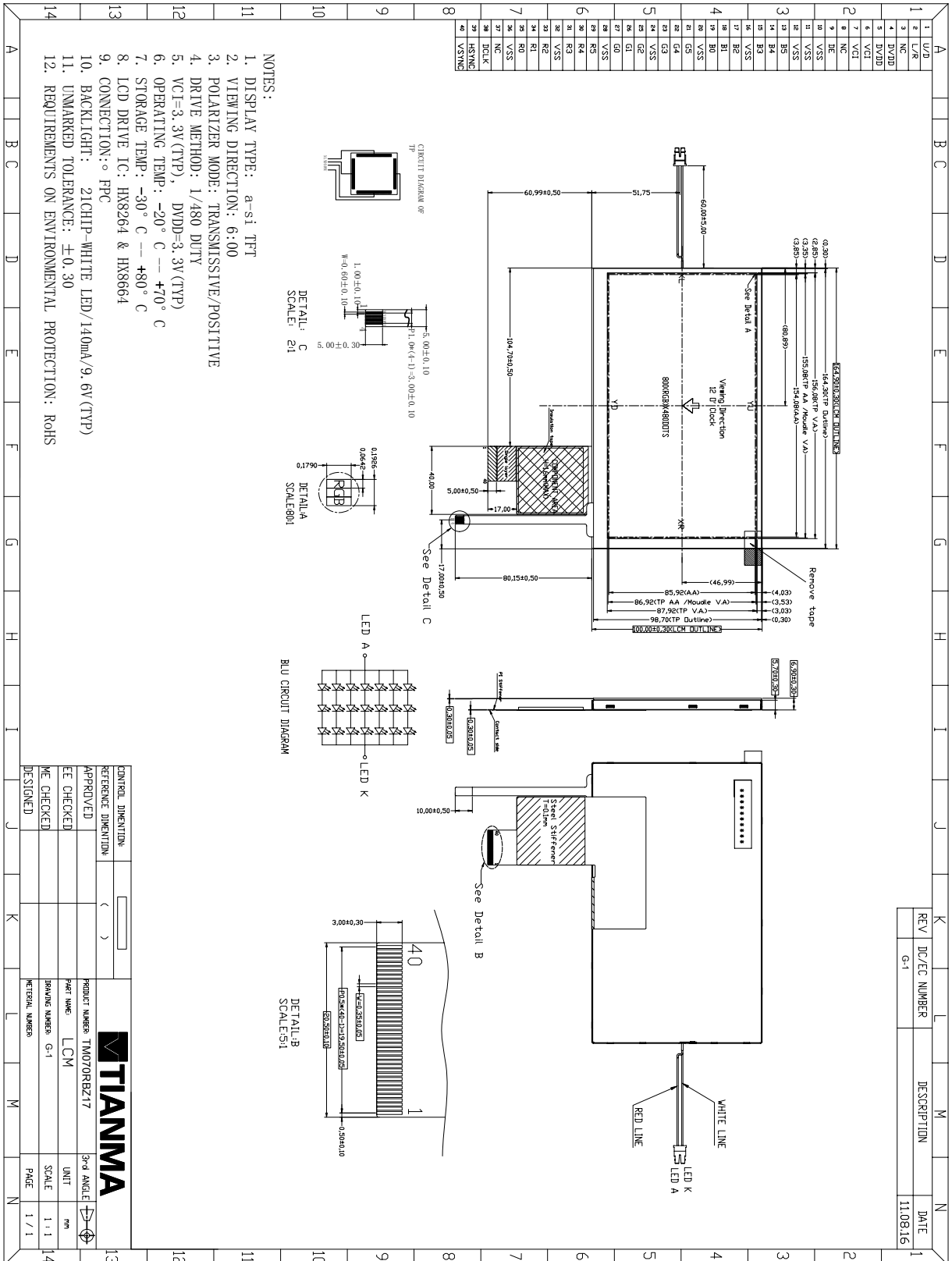

3. Circuit Block Diagram

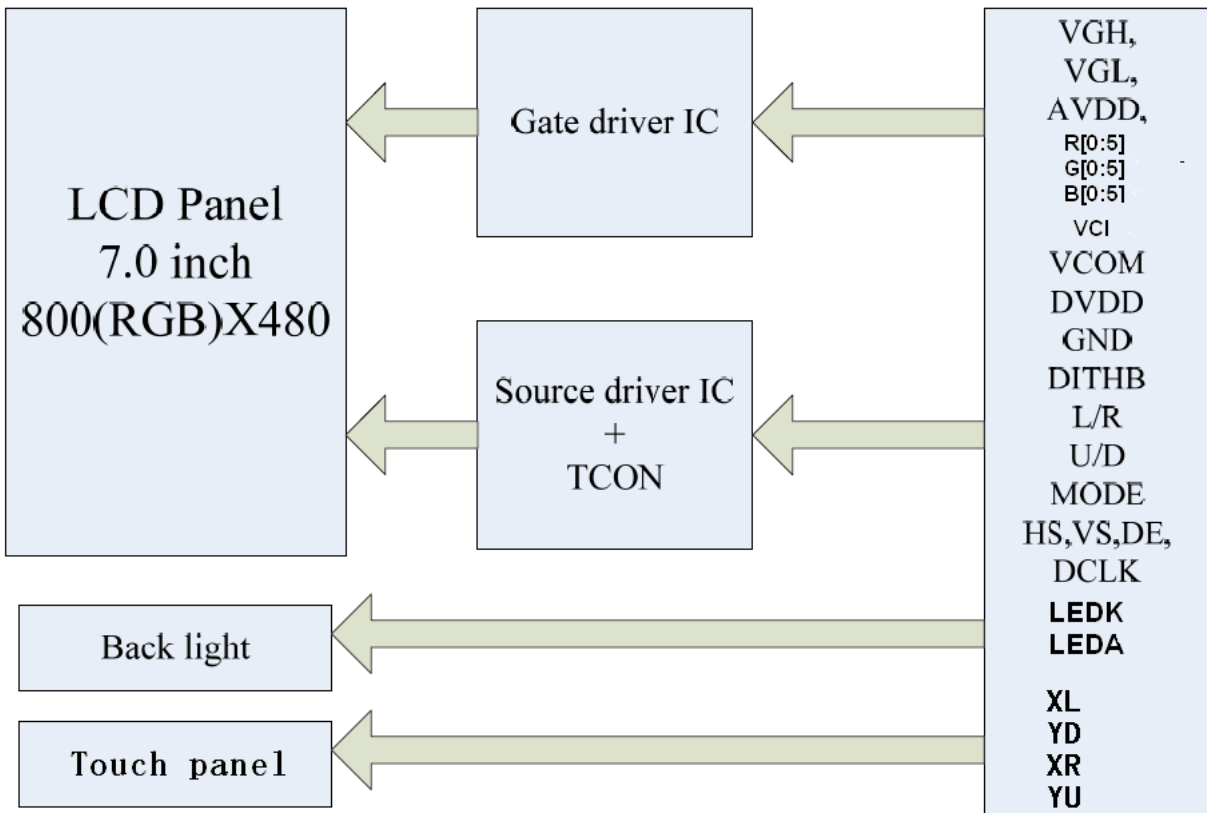

4. Absolute Maximum Ratings(Ta=25°C)

Item	Symbol	Min.	Max.	Unit	Note
Power Supply Voltage	VCI	2.5	5.0	V	1, 2
Logic Signal Input /Output Voltage	DVDD	2.7	3.6	V	
Operating Temperature	Top	-20	+70	°C	
Storage Temperature	Tst	-30	+80	°C	

Notes:

1. If the module is above these absolute maximum ratings. It may become permanently damaged.
Using the module within the following electrical characteristic conditions are also exceeded, the module will malfunction and cause poor reliability.
2. DVDD >V_{SS} must be maintained.

5. Electrical Specifications and Instruction Code

5.1 Electrical characteristics(V_{ss}=0V ,Ta=25°C)

Parameter		Symbol	Condition	Min	Typ	Max	Unit	Note
Input voltage	'H'	V _{IH}		0.7DVDD	-	DVDD	V	
	'L'	V _{IL}		V _{ss}	-	0.3DVDD	V	
Output Voltage	'H'	V _{OH}	-	DVDD-0.4	-	DVDD	V	
	'L'	V _{OL}	-	V _{ss}	-	V _{ss} +0.4	V	
Current Consumption		I _{CC1}	Normal mode	-	-	-	mA	1
		I _{CC2}	Standby mode	-	-	-	mA	2

Note:

1: Display full white.No include Backlight .

2: IC on standby mode.

5.2 LED backlight specification($V_{SS}=0V$, $T_a=25^{\circ}C$)

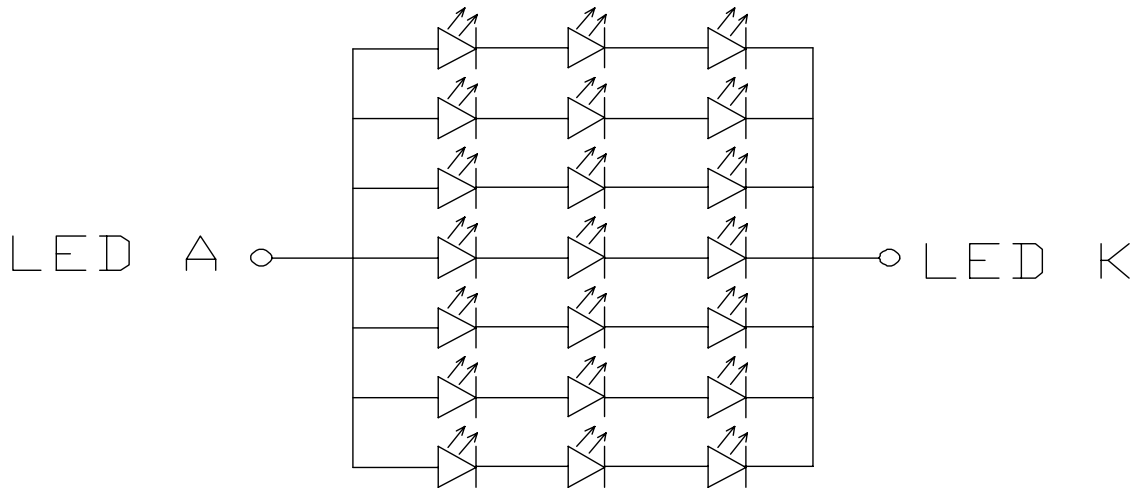

BLU CIRCUIT DIAGRAM

Item	Symbol	Condition	Min	Typ	Max	Unit	Note
Supply voltage		$I_f=140mA$	--	9.6	11.4	V	
Supply current	I_f	-	-	20 x7	-	mA	
Operating life time	-	-	10000	20000		Hour	1,2
Forward current	Normal	I_{pn}	21-chip	--	20x7	--	mA
	Dimming	I_{pd}		--	--	--	

Note:

● Note1: Under LCM operating, the stable forward current should be inputted. And forward voltage is for reference only.

Note2: Optical performance should be evaluated at $T_a=25^{\circ}C$ only. If LED is driven by high current, high ambient temperature & humidity condition. The life time of LED will be reduced. Operating life means brightness goes down to 50% initial brightness. Typical operating life time is estimated data.

5.3 Interface Signals

Pin No.	Symbol	I/O	Function
1	U/D	I	Up/down selection
2	L/R	I	Left/ Right selection
3	NC/RESET	I	No Connection Or Reset Pin for LCM active low
4	DVDD	P	Power Logic Supply(+3.3V)
5	DVDD	P	Power Logic Supply(+3.3V)
6	VCI	P	Power Supply(+3.3V)
7	VCI	P	Power Supply(+3.3V)
8	NC	-	No Connection
9	DE	I	Data Enable Control Pin
10	VSS	P	Power Ground (0V)
11	VSS	P	Power Ground (0V)
12	VSS	P	Power Ground (0V)
13	B5	I	Blue Data Bit 5
14	B4	I	Blue Data Bit 4
15	B3	I	Blue Data Bit 3
16	VSS	P	Power Ground (0V)
17	B2	I	Blue Data Bit 2
18	B1	I	Blue Data Bit 1
19	B0	I	Blue Data Bit 0(LSB)
20	VSS	P	Power Ground (0V)
21	G5	I	Green Data Bit 5
22	G4	I	Green Data Bit 4
23	G3	I	Green Data Bit 3
24	VSS	P	Power Ground (0V)
25	G2	I	Green Data Bit 2
26	G1	I	Green Data Bit 1
27	G0	I	Green Data Bit 0(LSB)

5.3 Interface Signals(continued)

Pin No.	Symbol	I/O	Function
28	VSS	P	Power Ground (0V)
29	R5	I	Red Data Bit 5
30	R4	I	Red Data Bit 4
31	R3	I	Red Data Bit 3
32	VSS	P	Power Ground (0V)
33	R2	I	Red Data Bit 2
34	R1	I	Red Data Bit 1
35	R0	I	Red Data Bit 0(LSB)
36	VSS	P	Power Ground (0V)
37	NC	-	No Connection
38	DCLK	I	Pixel clock
39	HSYNC	I	Horizontal synchronizing signal.
40	VSYNC	I	Vertical synchronizing signal.

LED BACKLIGHT:

Pin No.	Symbol	I/O	Function
1	A	P	Anode for LED backlight (red line)
2	K	P	Cathode for LED backlight (black line)

TOUCH PANEL:

Pin No.	Symbol	I/O	Function
1	XL	-	Touch panel pin (left)
2	YD	-	Touch panel pin (down)
3	XR	-	Touch panel pin (right)
4	YU	-	Touch panel pin (up)

Note1: I/O definition.

I---Input pin, O---Output pin, P--- Power/Ground, N--- No connection

5.4 Interface Timing Chart

- Horizontal timing

Parameter	Symbol	Spec.			Unit
		Min.	Typ.	Max.	
Horizontal Display Area	thd	800			DCLK
DCLK frequency	fclk	-	30	50	MHz
One Horizontal Line	th	862	1056	1200	DCLK
HS pulse width	thpw	1	-	40	DCLK
HS Back Porch (Blanking)	thb	46			DCLK
HS Front Porch	thfp	16	210	354	DCLK
DE mode Blanking	th-thd	85	256	400	DCLK

- Vertical timing

Parameter	Symbol	Spec.			Unit
		Min.	Typ.	Max.	
Vertical Display Area	tvd	480			T _H
VS period time	tv	513	525	650	T _H
VS pulse width	tvpw	3	-	20	T _H
VS Back Porch (Blanking)	tvb	23			T _H
VS Front Porch	tvfp	7	22	147	T _H
DE mode Blanking	tv-tvd	30	45	170	T _H

Note: Base on HX8264-D05

Timing Diagram

- Horizontal timing

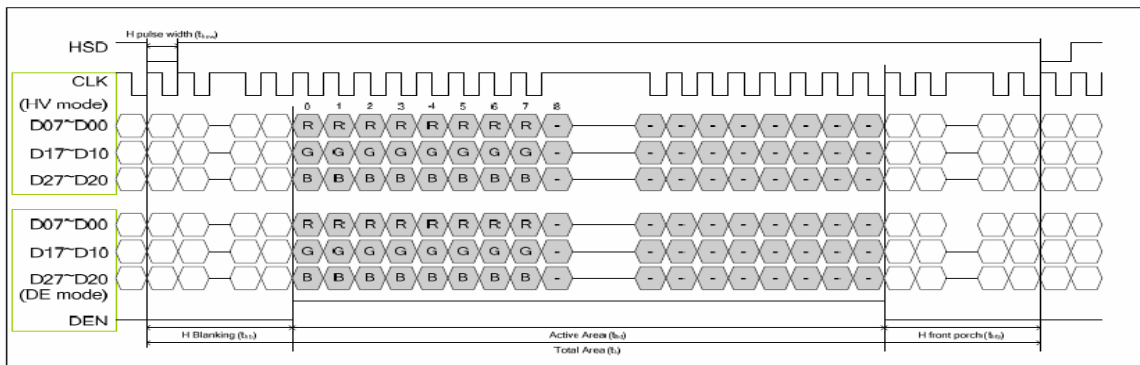

Figure 11. 1: Horizontal Input Timing Diagram

- Vertical timing

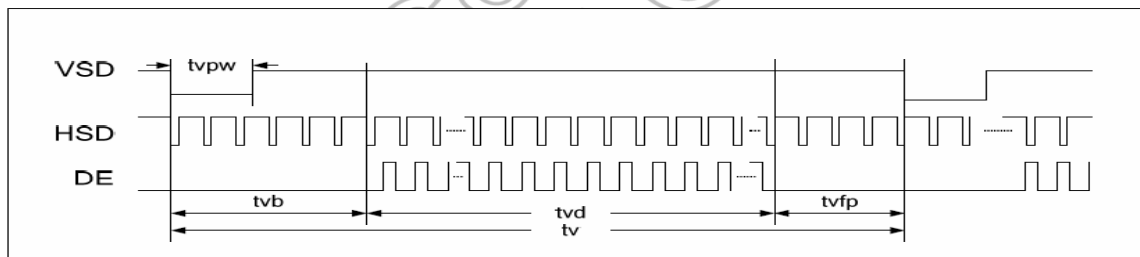

Figure 11. 2: Vertical Input Timing Diagram

6. Optical Characteristics

Item	Symbol	Condition	Min.	Typ.	Max.	Unit	Note
Brightness	Bp	$\theta=0^\circ$	--	270	--	Cd/m ²	1
Uniformity	ΔBp	$\Phi=0^\circ$	--	80%	--	%	1,2
Viewing Angle	θU	CR>10	--	53	--	Degree	3
	θD		-	66	--		
	θL		--	70	--		
	θR		--	70	--		
Contrast Ratio	Cr	$\theta=0^\circ$	-	400	-	-	4
Response Time	$T_r + T_f$	$\Phi=0^\circ$	-	25	40	ms	5
Color of CIE Coordinate	W	x	-	0.32	-	-	1,6
		y	-	0.34	-	-	
	R	x	-	0.59	-	-	
		y	-	0.34	-	-	
	G	x	-	0.35	-	-	
		y	-	0.57	-	-	
	B	x	-	0.14	-	-	
		y	-	0.10	-	-	
	NTSC Ratio	S	$\theta=0^\circ$ $\Phi=0^\circ$	-	50.0	-	

Note: The parameter is slightly changed by temperature, driving voltage and material.

Note 1: The data are measured after LEDs are turned on for 5 minutes. LCM displays full white.

The brightness is the average value of 9 measured spots. Measurement equipment PR-705 ($\Phi 8\text{mm}$)

Measuring condition:

- Measuring surroundings: Dark room.
- Measuring temperature: Ta=25°C.
- One LED current is 20mA
- Adjust operating voltage to get optimum contrast at the center of the display.

Measured value at the center point of LCD panel after more than 5 minutes while backlight turning on.

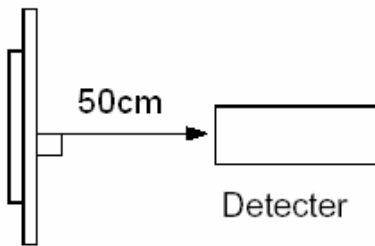

Note 2: The luminance uniformity is calculated by using following formula.

$$\Delta B_p = B_p (\text{Min.}) / B_p (\text{Max.}) \times 100 (\%)$$

Bp (Max.) = Maximum brightness in 9 measured spots

Bp (Min.) = Minimum brightness in 9 measured spots.

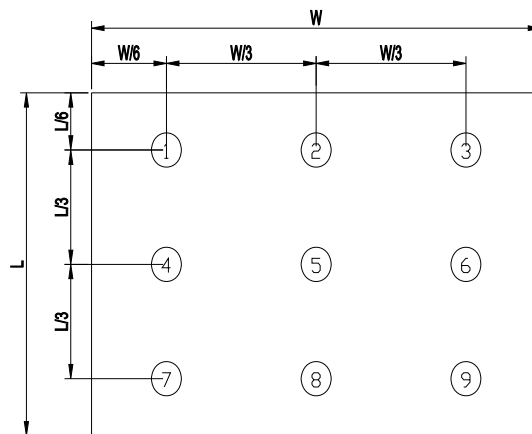

Measurement equipment PR-705 (Φ8mm)

Note 3: The definition of viewing angle:

Refer to the graph below marked by θ and ϕ

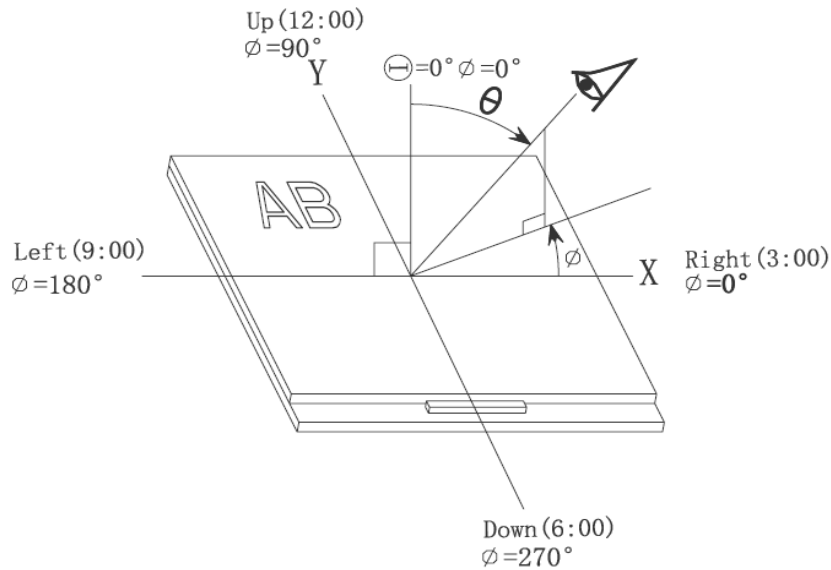

Note 4: The definition of contrast ratio (Test LCM using PR-705):

$$\text{Contrast Ratio(CR)} = \frac{\text{Luminance When LCD is at "White" state}}{\text{Luminance When LCD is at "Black" state}}$$

(Contrast Ratio is measured in optimum common electrode voltage)

Note 5: Definition of Response time. (Test LCD using DMS501):

The output signals of photo detector are measured when the input signals are changed from "black" to "white"(falling time) and from "white" to "black"(rising time), respectively. The response time is defined as the time interval between the 10% and 90% of amplitudes. Refer to figure as below.

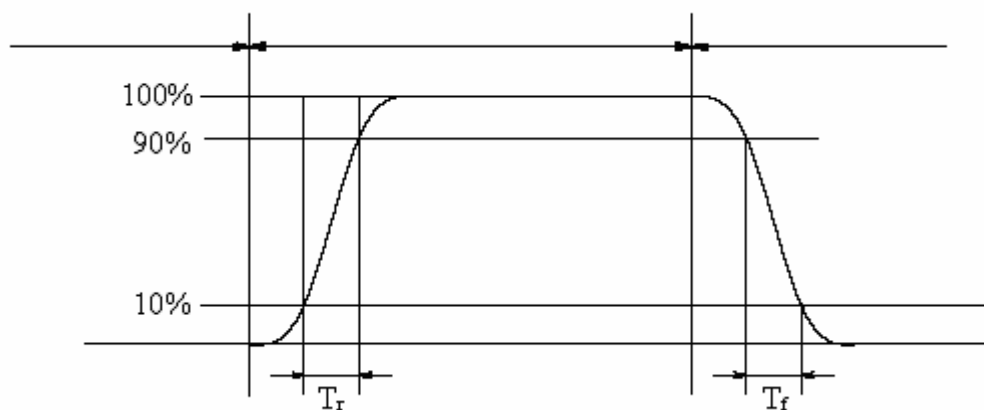

The definition of response time

Note 6: Definition of Color of CIE Coordinate and NTSC Ratio.

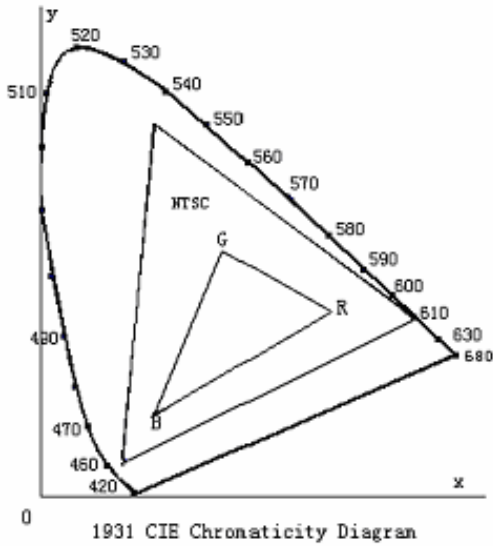

Color gamut:

$$S = \frac{\text{area of RGB triangle}}{\text{area of NTSC triangle}} \times 100\%$$

7. Reliability Test Items and Criteria

No	Test Item	Test condition	Criterion
1	High Temperature Storage	80 °C±2°C 120 H Restore 2H at 25°C Power off	After testing, cosmetic and electrical defects should not happen.
2	Low Temperature Storage	-30°C±2°C 120 H Restore 2H at 25°C Power off	
3	High Temperature Operation	70 °C±2°C 120 H Restore 2H at 25°C Power on	
4	Low Temperature Operation	-20°C±2°C 120 H Restore 4H at 25°C Power on	
5	High Temperature & Humidity Operation	40°C±2°C 90%RH 120 H Power on	
6	Temperature Cycle	-20°C←→25°C←→70 °C 30min 5min 30min after 10cycle, Restore 2H at 25°C Power off	
7	Vibration Test	Frequency range:10~55Hz, Stroke:1.5mm Sweep:10Hz~55Hz~10Hz 2 hours for each direction of X.Y.Z.	
8	Shock Test	60G 6ms, ±X,±Y,±Z 3times,for each direction	
9	Drop Test(package state)	Height:80 cm,1 corner, 3 edges, 6 surfaces	

10	ESD	C=150pF, R=330Ω, 5points/panel Air:±8KV, 5times; Contact:±4KV, 5 times; (Environment: 15℃ ~ 35℃,30% ~ 60%, 86Kpa ~ 106Kpa)	ISO10605
----	-----	--	----------

Note:Additional test Item proposed by customer shall be determined by mutual agreement between customer and Tianma

8 Quality level

8.1 Classification of defects

Major defects (MA): A major defect refers to a defect that may substantially degrade usability for product applications, including all functional defects(such as no display, abnormal display, open or missing segment, short circuit, missing component), outline dimension beyond the drawing, progressive defects and those affecting reliability.

Minor defects (MI): A minor defect refers to a defect which is not considered to be able to substantially degrade the product application or a defect that deviates from existing standards almost unrelated to the effective use of the product or its operation, such as black spot, white spot, bright spot, pinhole, black line, white line, contrast variation, glass defect, polarizer defect, etc.

8.2 Definition of inspection range

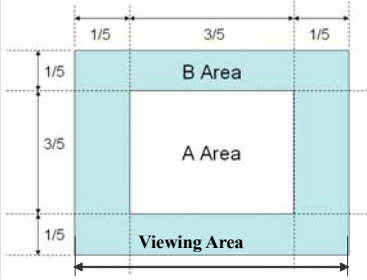
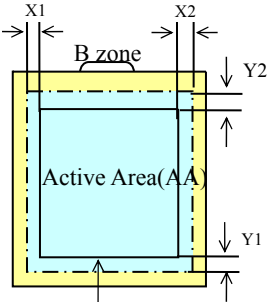
<p>For dot defect of TFT LCD which is not smaller than 3 inches, dividing three areas to make a judgment (according to figure 1).</p> <p>A area : center of viewing area B area : periphery of viewing area C area : Outside viewing area</p> <p>For other defects, dividing two areas to make a judgment (according figure 2).</p> <p>A zone : Inside Viewing area B zone : Outside Viewing area</p> <p>X1(A.A~V.A): 0mm X2(A.A~V.A): 0mm Y1(A.A~V.A): 0mm Y2(A.A~V.A): 0mm</p>	 <p>Figure 1</p>  <p>Figure 2</p>
--	--

8.3 Inspection items and general notes

General notes	<p>①Should any defects which are not specified in this standard happen, additional standard shall be determined by mutual agreement between customer and TIANMA.</p> <p>②Viewing area should be the area which TIANMA guarantees.</p> <p>③Limit sample should be prior to this Inspection standard.</p> <p>④Viewing judgment should be under static pattern.</p> <p>⑤Inspection conditions Inspection distance: 250 mm (from the sample) Temperature : 25±5 °C Inspection angle : 45 degrees in 12 o'clock direction (all defects in viewing area should be inspected from this direction)</p>	
Inspection items	Pinhole, Bright spot, Black spot, White spot, Black line, White Line, Foreign particle, Bubble	The color of a small area is different from the remainder. The phenomenon doesn't change with voltage
	Contrast variation	The color of a small area is different from the remainder. The phenomenon changes with voltage
	Polarizer defect	Scratch, Dirt, Particle, Bubble on polarizer or between polarizer and glass
	Dot defect (TFT LCD)	The pixel appears bright or dark abnormally when display
	Functional defect	No display, Abnormal display, Open or missing segment, Short circuit, False viewing direction
	Glass defect	Glass crack, Shaved corner of glass, Surplus glass

PCB defect	Components assembly defect
------------	----------------------------

8.4 Outgoing Inspection level

Outgoing Inspection standard	Inspection conditions	Inspection				
		Min.	Max.	Unit	IL	AQL
Major Defects	See 8.3 general notes	See 8.5			II	0.65
Minor Defects	See 8.3 general notes	See 8.5			II	1.5

Note: Sampling standard conforms to GB2828

8.5 Inspection Items and Criteria

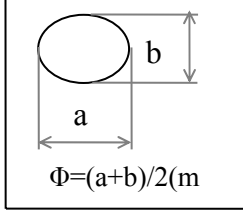
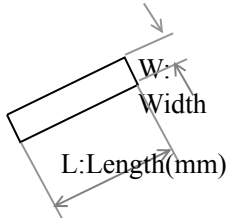
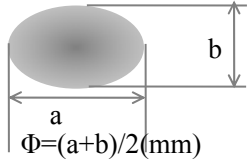
Inspection items		Judgment standard				
		Category		Acceptable number		
				A zone	B zone	
1	Black spot, White spot, Bright Spot, Pinhole, Foreign Particle, Particle in or on glass, Scratch on glass 	A	$\Phi \leq 0.10$	Neglected		
		B	$0.10 < \Phi \leq 0.15$	2		
		C	$0.15 < \Phi \leq 0.20$	1		
		D	$0.20 < \Phi$	0		
		Total defective point(B,C)		3		Neglected
2	Black line, White line, and Particle Between Polarizer and glass, Scratch on glass 	A	$W \leq 0.01$	Neglected		
		B	$0.01 < W \leq 0.03 \quad L \leq 3.0$	2		
		C	$0.03 < W \leq 0.05 \quad L \leq 3.0$	1		
		D	$0.05 < W$	0		
		Total defective point(B,C)		3		Neglected
3	Contrast variation 	A	$\Phi \leq 0.2$	Neglected		
		B	$0.2 < \Phi \leq 0.3$	2		
		C	$0.3 < \Phi \leq 0.4$	1		
		D	$0.4 < \Phi$	0		
		Total defective point(B,C)		3		Neglected
4	Dot defect (if TFT LCD is used) TFT LCD is smaller than 3 inches	LCD Class	Defect	A area	B area	
		A	Bright dot	1	Neglected	
			Dark dot	2		
Total	2					

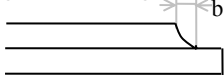
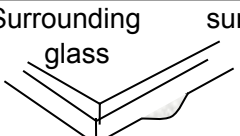
		TFT LCD between 3~10.4 inches	B	Bright dot	2		C area				
				Dark dot	3						
				Total	4						
			A	Defect	A area	B area	C area	Bright dot	1	1	
								Dark dot	1	2	
								Total	4		
								B	Bright dot	2	2
									Dark dot	2	3
									Total	6	
			<p>Notes: Bright dot: in R、G、B or dark display figure, the pixel appears bright. Dark dot: in R、G、B or white display figure, the pixel appears dark. Defect area must be less than an half size of the dot.</p>								
5	Bubble inside cell	any size			none	none					
6	Polarizer defect (if is Polarizer used)	Scratch ,damage on polarizer, Particle on polarizer or between polarizer and glass. Bubble, dent and convex	Refer to item 1 and item 2.								
			A	$\Phi \leq 0.3$	Neglected		Neglected				
			B	$0.3 < \Phi \leq 0.7$	2						
			C	$0.7 < \Phi$	0						
7	Surplus glass	Stage surplus glass 	$b \leq 0.3\text{mm}$								
		Surrounding surplus glass 	Should not influence outline dimension and assembling.								
8	Open segment or open common	Not permitted									
9	Short circuit	Not permitted									
10	False viewing direction	Not permitted									
11	Contrast ratio uneven	According to the limit specimen									
12	Crosstalk	According to the limit specimen									
13	Black /White spot(display)	Refer to item 1									
14	Black /White line(display)	Refer to item 2									

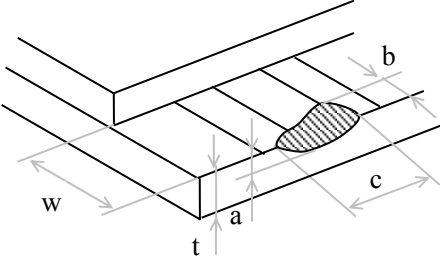
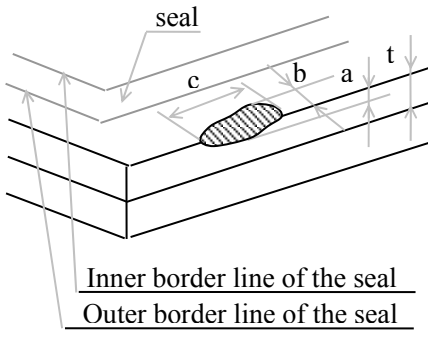
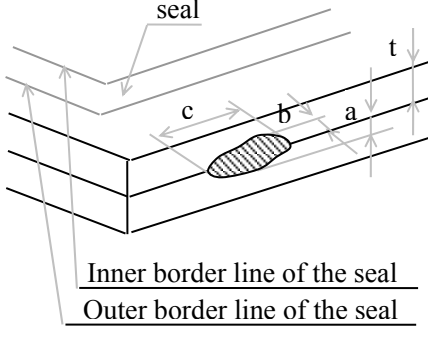
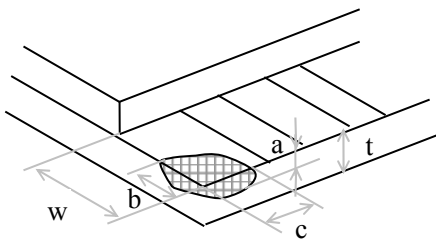
Inspection items		Judgment standard		Acceptable number		
		Category(application: B zone)				
15	Glass defect crack	①The front of lead terminals	A	$a \leq t, b \leq 1/5W, c \leq 3\text{mm}$	Max.3 defects allowed	
			B	Crack at two sides of lead terminals should not cover patterns and alignment mark		
			②Surrounding crack—non-contact side	 <p>$b < \text{Inner border line of the seal}$</p>		
			③ Surrounding crack— contact side			 <p>$b < \text{Outer border line of the seal}$</p>
④Corner	A	$a \leq t, b \leq 3.0, c \leq 3.0$	B	Glass crack should not cover patterns u and alignment mark and patterns.		
						

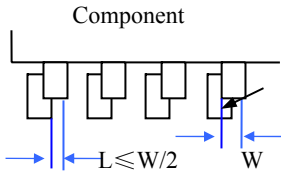
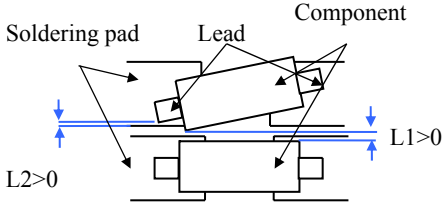
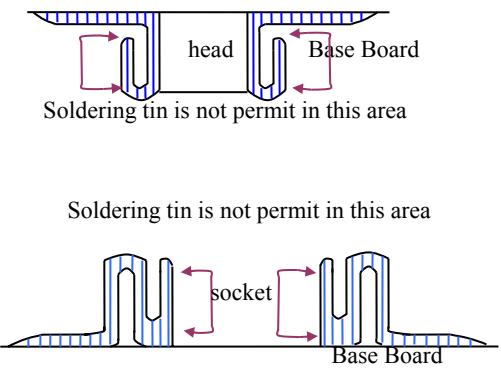
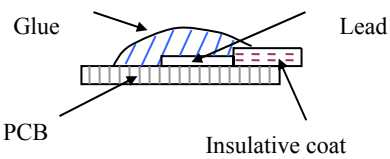
Inspection items		Judgment standard	
		Category(application: B zone)	
1 6	PCB defect	<p>Component soldering: No cold soldering、short、open circuit、burr、tin ball The flat encapsulation component position deviation must be less than 1/3 width of the pin (Pic.1); the sheet component deviation: Pin deviates from the pad and contact with the near components is not permitted (Pic.2)</p>	
		<p>lead defect: The lead lack must be less than 1/3 of its width; The lead burr must be less than 1/3 of the seam; Impurities connect with the near leads is not permitted</p>	
		<p>Connector soldering: Soldering tin is at contact position of the plug and socket is not permitted No foundation is scald Serious cave distortion on plug and socket contact pin is not permitted</p>	
	<p>Glue on root of the speaker receiver and motor lead: The insulative coat of the lead must join into the PCB; the protected glue must envelop to the insulative coat.</p>		

9. Precautions for Use of LCD Modules

9.1 Handling Precautions

- 9.1.1 The display panel is made of glass. Do not subject it to a mechanical shock by dropping it from a high place, etc.
- 9.1.2 If the display panel is damaged and the liquid crystal substance inside it leaks out, be sure not to get any in your mouth, if the substance comes into contact with your skin or clothes, promptly wash it off using soap and water.
- 9.1.3 Do not apply excessive force to the display surface or the adjoining areas since this may cause the color tone to vary.
- 9.1.4 The polarizer covering the display surface of the LCD module is soft and easily scratched. Handle this polarizer carefully.
- 9.1.5 If the display surface is contaminated, breathe on the surface and gently wipe it with a soft dry cloth. If still not completely clear, moisten cloth with one of the following solvents:
- Isopropyl alcohol
 - Ethyl alcohol
- Solvents other than those mentioned above may damage the polarizer. Especially, do not use the following:
- Water
 - Ketone
 - Aromatic solvents
- 9.1.6 Do not attempt to disassemble the LCD Module.
- 9.1.7 If the logic circuit power is off, do not apply the input signals.
- 9.1.8 To prevent destruction of the elements by static electricity, be careful to maintain an optimum work environment.
- a. Be sure to ground the body when handling the LCD Modules.
 - b. Tools required for assembly, such as soldering irons, must be properly ground.
 - c. To reduce the amount of static electricity generated, do not conduct assembly and other work under dry conditions.
 - d. The LCD Module is coated with a film to protect the display surface. Be care when peeling off this protective film since static electricity may be generated.

9.2 Storage precautions

- 9.2.1 When storing the LCD modules, avoid exposure to direct sunlight or to the light of fluorescent lamps.
- 9.2.2 The LCD modules should be stored under the storage temperature range. If the LCD modules will be stored for a long time, the recommend condition is:
- Temperature : 0°C ~ 40°C
- Relatively humidity: ≤80%
- 9.2.3 The LCD modules should be stored in the room without acid, alkali and harmful gas.

9.3 The LCD modules should be no falling and violent shocking during transportation,

and also should avoid excessive press, water, damp and sunshine.

9.4 Display defects inspection item and limit criteria

About display defects inspection item and limit criteria ,please refer to the content of 《LCM-T FT liquid display module》（Q/DDG199-2007） and 《liquid display module display defects inspection standard》（Q/DDG439-1999）。