



MODEL NO. : TM070RDH13

ISSUED DATE: 2011-07-20

VERSION : Ver. 2.0

- Preliminary Specification
- Final Product Specification

Customer : \_\_\_\_\_

Approved by	Notes

SHANGHAI AVIC Confirmed :

Prepared by	Checked by	Approved by
YE.CHEN 2011.7.20	Hyman Chen 2011.7.20	Anfernee Du 2011.7.20

This technical specification is subjected to change without notice

The information contained herein is the exclusive property of SHANGHAI AVIC OPTOELECTRONICS Corporation, and shall not be distributed, reproduced, or disclosed in whole or in part without prior written permission of SHANGHAI AVIC OPTOELECTRONICS Corporation.



## Table of Contents

Table of Contents .....	2
Record of Revision.....	3
1 General Specifications .....	4
2 Input/Output Terminals .....	5
3 Absolute Maximum Ratings .....	7
4 Electrical Characteristics.....	8
5 Timing Chart.....	11
6 Optical Characteristics .....	14
7 Environmental / Reliability Test .....	17
8 Mechanical Drawing.....	18
9 Packing drawing.....	19
10 Precautions for Use of LCD Modules.....	20

AVIC CONFIDENTIAL





## 1 General Specifications

	Feature	Spec
<b>Display Spec.</b>	Size	7 inch
	Resolution	800(RGB) x 480
	Interface	RGB 24 bits with TCON
	Color Depth	16.7M
	Technology Type	a-Si
	Pixel Pitch (mm)	0.1926 (H) x 0.1790(V)
	Pixel Configuration	R.G.B. Vertical Stripe
	Display Mode	TM with Normally White
	Surface Treatment(Up Polarizer)	Anti Glare
	Viewing Direction	12 o'clock
	Gray Scale Inversion Direction	6 o'clock
<b>Mechanical Characteristics</b>	LCM (W x H x D) (mm)	164.9x 100.0 x 5.7
	Active Area(mm)	154.08 (W) x 85.92 (H)
	With /Without TSP	Without TSP
	Weight (g)	160g
	LED Numbers	18 LEDs

Note 1: Viewing direction for best image quality is different from TFT definition. There is a 180 degree shift.

Note 2: Requirements on Environmental Protection: RoHS

Note 3: LCM weight tolerance: +/- 5%



## 2 Input/Output Terminals

### 2.1 CN1 of FPC

Pin No.	Symbol	I/O	function	Remarks
1	VLED+	P	Power for LED backlight(anode)	
2	VLED+	P	Power for LED backlight(anode)	
3	VLED-	P	Power for LED backlight(Cathode)	
4	VLED-	P	Power for LED backlight(Cathode)	
5	GND	P	Power ground	
6	VCOM	I	Common voltage	
7	DVDD	P	Power for digital circuit	
8	MODE	I	DE/SYNC mode select. Normally pull high	MODE=1,DE mode, VS and HS must pull high; MODE=0, HSD/VSD mode, DE must be grounded
9	DE	I	DATA INPUT Enable	
10	VS	I	VERTICAL SYNC INPUT	
11	HS	I	Horizontal Sync Input	
12	B7	I	Blue data(MSB)	
13	B6	I	Blue data	
14	B5	I	Blue data	
15	B4	I	Blue data	
16	B3	I	Blue data	
17	B2	I	Blue data	
18	B1	I	Blue data	When input 18 bits RGB data, B1 must be grounded
19	B0	I	Blue data(LSB)	When input 18 bits RGB data, B0 must be grounded
20	G7	I	Green data(MSB)	
21	G6	I	Green data	
22	G5	I	Green data	
23	G4	I	Green data	
24	G3	I	Green data	
25	G2	I	Green data	
26	G1	I	Green data	When input 18 bits RGB data, G1 must be grounded
27	G0	I	Green data(LSB)	When input 18 bits RGB data, G0 must be grounded
28	R7	I	RED data(MSB)	
29	R6	I	RED data	
30	R5	I	RED data	
31	R4	I	RED data	
32	R3	I	RED data	
33	R2	I	RED data	
34	R1	I	RED data	When input 18 bits RGB data, R1 must be grounded
35	R0	I	RED data(LSB)	When input 18 bits RGB data, R0 must be grounded

The information contained herein is the exclusive property of SHANGHAI AVIC OPTOELECTRONICS Corporation, and shall not be distributed, reproduced, or disclosed in whole or in part without prior written permission of SHANGHAI AVIC OPTOELECTRONICS Corporation.



36	GND	P	Power ground	
37	DCLK	I	Sample clock	Data shall be latched at the falling edge of DCLK
38	GND	I	Power ground	
39	L/R	I	Left/right selection	Selection of scanning mode
40	U/D	I	Up/down selection	Selection of scanning mode
41	VGH	P	Gate on voltage	
42	VGL	P	Gate off voltage	
43	AVDD	P	Power for analog circuit	
44	RESET	I	Global reset pin	Active low to enter reset state, suggest to connect with an RC reset circuit for stability. Normally pull high
45	NC	-	No connection	
46	VCOM	I	Common voltage	
47	DITHB	I	Dithering function enable control, normally pull high;	When DITHB=1, disable internal dithering function; When DITHB=0, enable internal dithering function;
48	GND	P	Power ground	
49	NC	-	No connection	
50	NC	-	No connection	

Note: I/O definition.

I---Input pin, O---Output pin, P--- Power/Ground, N--- No Connection

## 2.2 U/D R/L Function Description

Scan Control Input		Scanning Direction
UPDN	SHLR	
GND	DVDD	Up to Down, Left to Right
DVDD	GND	Down to Up, Right to Left
GND	GND	Up to Down, Right to Left
DVDD	DVDD	Down to Up, Left to Right



### 3 Absolute Maximum Ratings

AGND= GND=0V, Ta = 25°C

Item	Symbol	Min	Max	Unit	Remark
Power Voltage	DVDD	-0.5	5.0	V	
	AVDD	-0.5	13.5	V	
	VGH	-0.3	+42	V	
	VGL	VGH-42	+0.3	V	
Backlight Forward Current	I <sub>LED</sub>	-	25	mA	For each LED
Operating Temperature	T <sub>OPR</sub>	-20	70	°C	
Storage Temperature	T <sub>STG</sub>	-30	80	°C	



## 4 Electrical Characteristics

### 4.1 Recommended Operating Condition

AGND=GND=0V, Ta = 25°C

Item	Symbol	Min	Typ	Max	Unit	Remark
Digital Supply Voltage	DVDD	3.0	3.3	3.6	V	
Analog Supply Voltage	AVDD	10.2	10.4	10.6	V	
Gate On Voltage	VGH	15.3	16.0	16.7	V	
Gate Off Voltage	VGL	-7.3	-7.0	-6.7	V	
Common Electrode Driving Signal	VCOM	3.6	3.7	3.8	V	

Note: The value is for design stage only.





### 4.2 Recommended Driving Condition for Backlight

Ta=25°C

Item	Symbol	Min	Typ	Max	Unit	Remark
Forward Current	$I_F$	18	20	25	mA	18 LEDs (3 LED Serial, 6 LED Parallel)
Forward Voltage	$V_F$	8.7	9.6	10.5	V	
Operating Life Time	-	20,000	-	-	Hrs	

Note1: The LED driving condition is defined for each LED module (3 LED Serial, 6 LED Parallel). For each LED:  $I_F (1/6) = 20\text{mA}$ ,  $V_F (1/3) = 3.2\text{V}$ .

Note2: Under LCM operating, the stable forward current should be inputted. And forward voltage is for reference only.

Note3:  $I_F$  is defined for one channel LED. Optical performance should be evaluated at  $T_a=25^\circ\text{C}$  only. If LED is driven by high current, high ambient temperature & humidity condition. The life time of LED will be reduced. Operating life means brightness goes down to 50% initial brightness. Typical operating life time is estimated data.

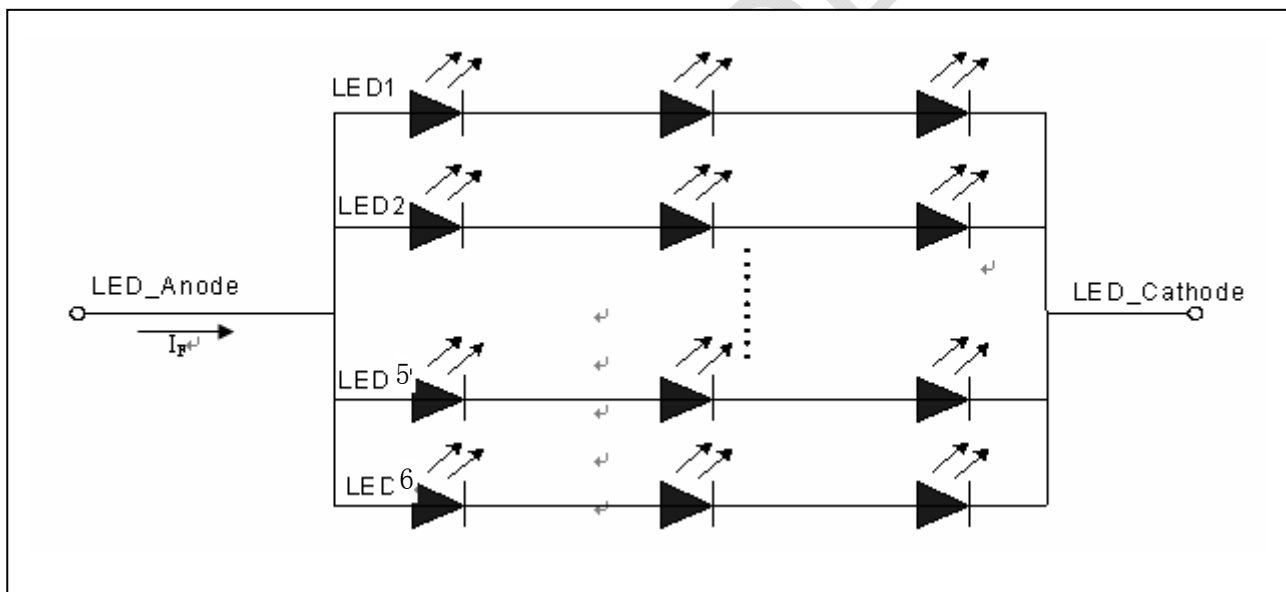

Note4: The LED driving condition is defined for each LED module.



## 4.3 Power Consumption

AGND=GND=0V, Ta = 25°C

Item	Symbol	Condition	Min	Typ	Max	Unit	Remark
Digital Supply Current	$I_{DVDD}$	DVDD=3.3V	-	3.22	8.70	mA	
Analog Supply Current	$I_{AVDD}$	AVDD=10.4V	-	15.69	23.01	mA	
Gate On Current	$I_{VGH}$	VGH=16.0V	-	0.20	0.22	mA	
Gate Off Current	$I_{VGL}$	VGL=-7.0V	-	0.20	0.22	mA	
Power Consumption	Panel&Gamma		-	177.67	254.65	mW	
	Backlight		-	1.152	1.267	W	
	Total		-	1.330	1.522	W	

## 4.4 Block Diagram

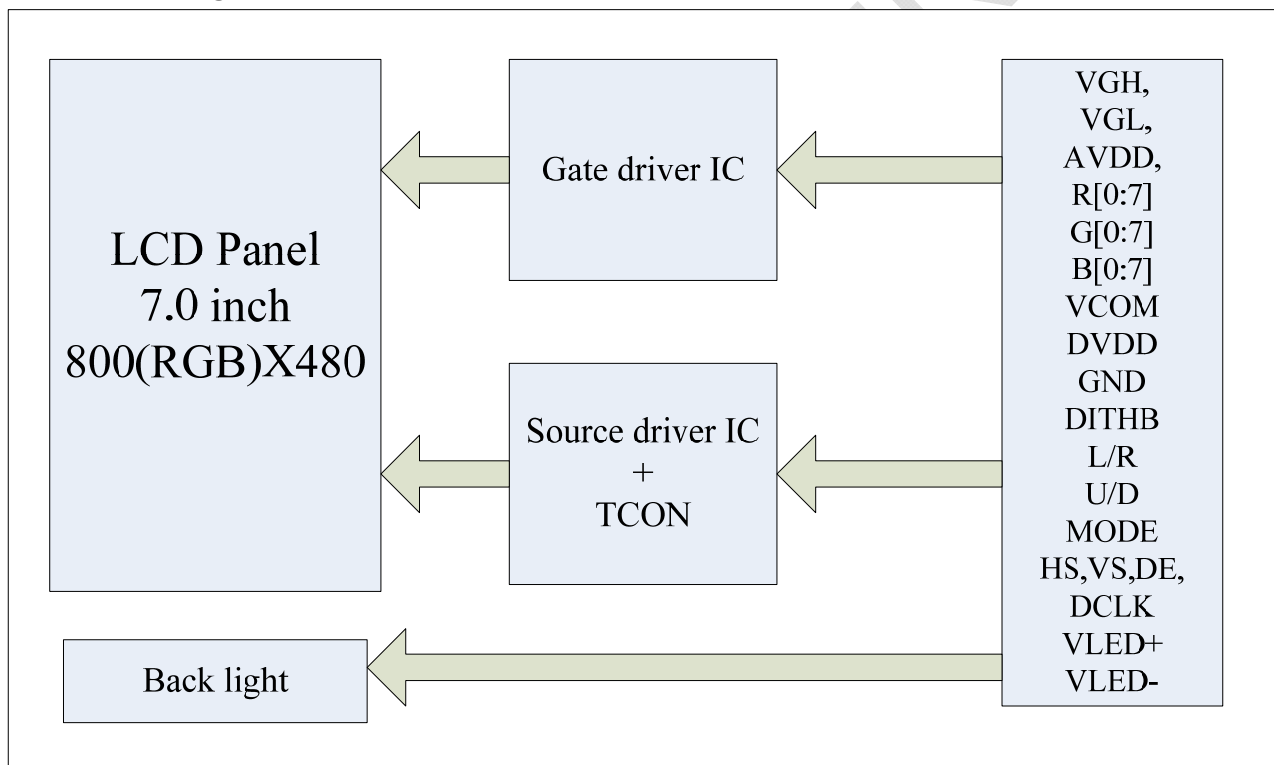



## 5 Timing Chart

### 5.1 TFT-LCD Input Timing

DVDD=3.3V, AVDD=10.4V, AGND=GND=0V, Ta=25°C

Parameter	Symbol	Min	Typ	Max	Unit	Conditions
DCLK Frequency	Fclk	-	30.0	40.0	MHz	
DCLK Cycle Time	Tcph	25.0	33.3	-	ns	
DCLK Pulse Width	Tcw	40%	50%	60%	Tcph	
VSD Setup Time	Tvst	8	-	-	ns	
VSD Hold Time	Tvhd	8	-	-	ns	
HSD Setup Time	Thst	8	-	-	ns	
HSD Hold Time	Thhd	8	-	-	ns	
Data Setup Time	Tdsu	8	-	-	ns	Data to DCLK
Data Hold Time	Tdhd	8	-	-	ns	Data to DCLK
DE Setup Time	Tesu	8	-	-	ns	
DE Hold Time	Tehd	8	-	-	ns	

#### Input Clock and Data timing Diagram:

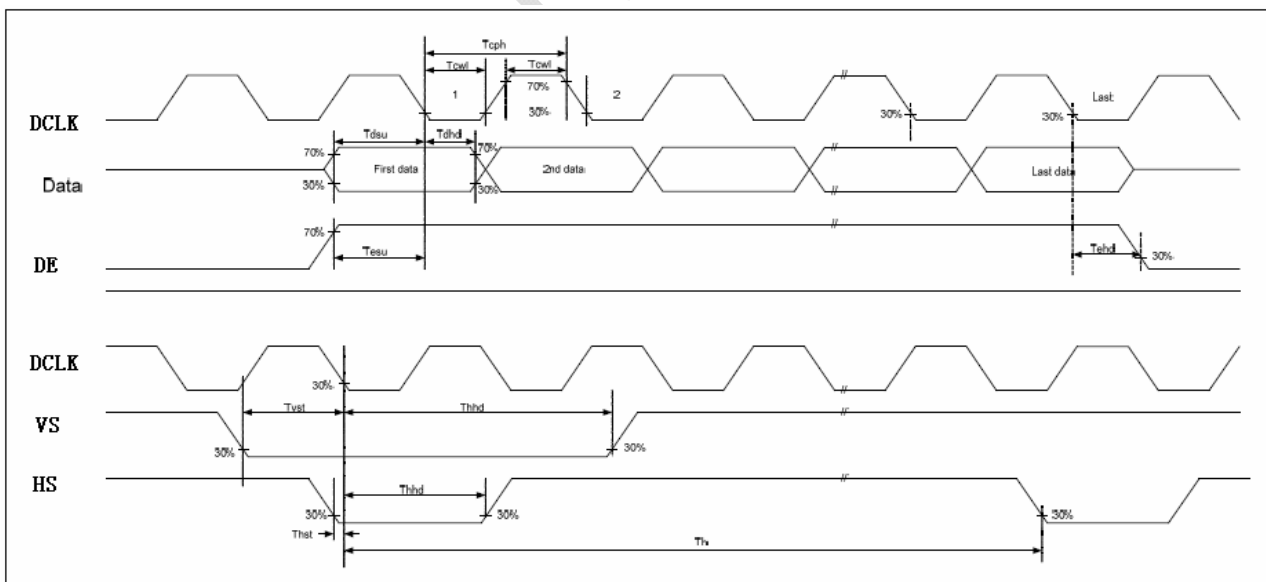

The information contained herein is the exclusive property of SHANGHAI AVIC OPTOELECTRONICS Corporation, and shall not be distributed, reproduced, or disclosed in whole or in part without prior written permission of SHANGHAI AVIC OPTOELECTRONICS Corporation.



## 5.2 Recommended Timing Setting Of TCON

## TCON (Embedded In Source IC) Input Timing (DCLK, HSD, VSD, DE)

Parameter	Symbol	Min	Typ	Max	Unit	Remark
DCLK	Fclk	-	30	40	MHZ	
	tclk	25.0	33.3	-	ns	
HSD	th	862	1056	1200	tclk	
	thd	-	800	-	tclk	
	thpw	1	-	40	tclk	
	thb	-	46	-	tclk	
	thfp	16	210	354	tclk	
VSD	tv	510	525	650	th	
	tvd	-	480	-	th	
	tvpw	1	-	20	th	
	tvb	-	23	-	th	
	tvfp	7	22	147	th	

Note: DE timing refer to HSD, VSD input timing.

## Vertical input timing Diagram:

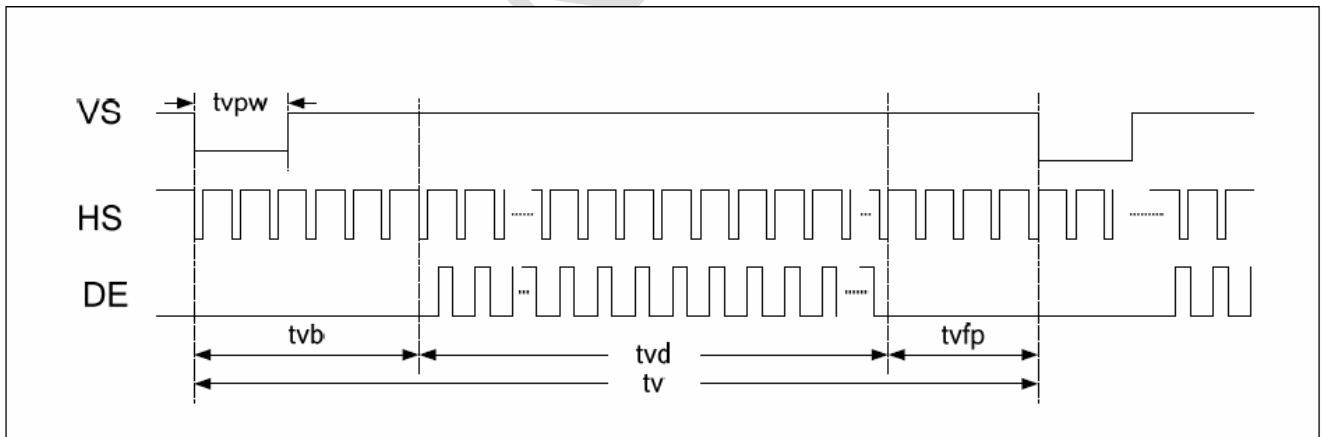



Horizontal input timing Diagram:

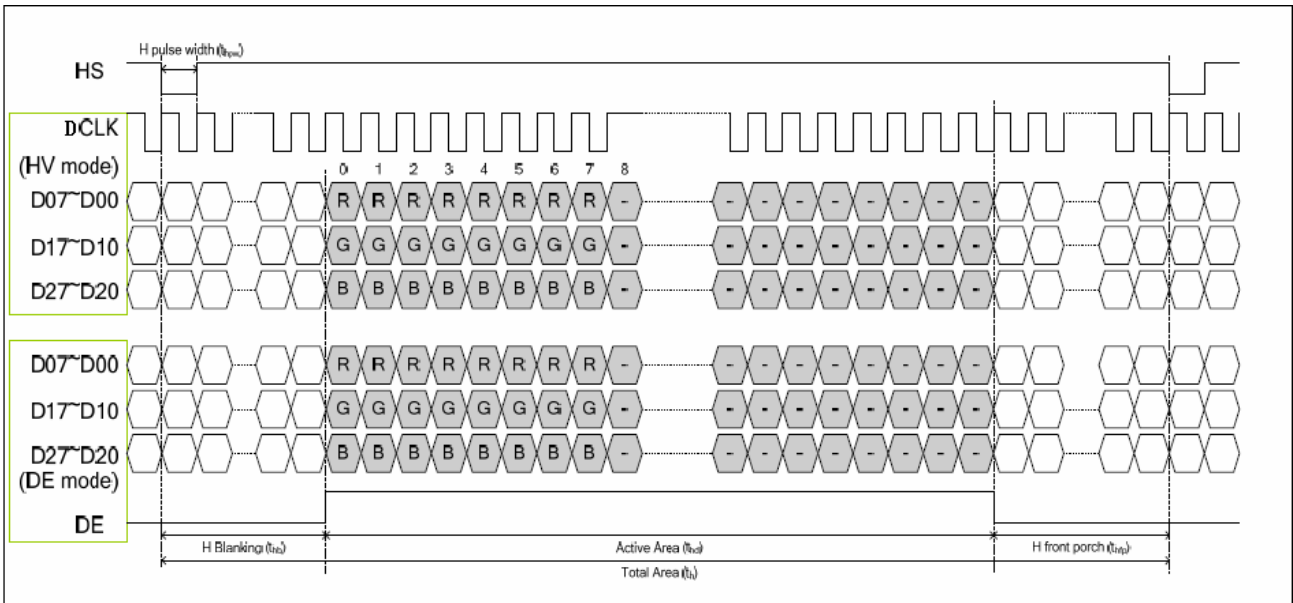

5.3 POWER ON/OFF SEQUENCE

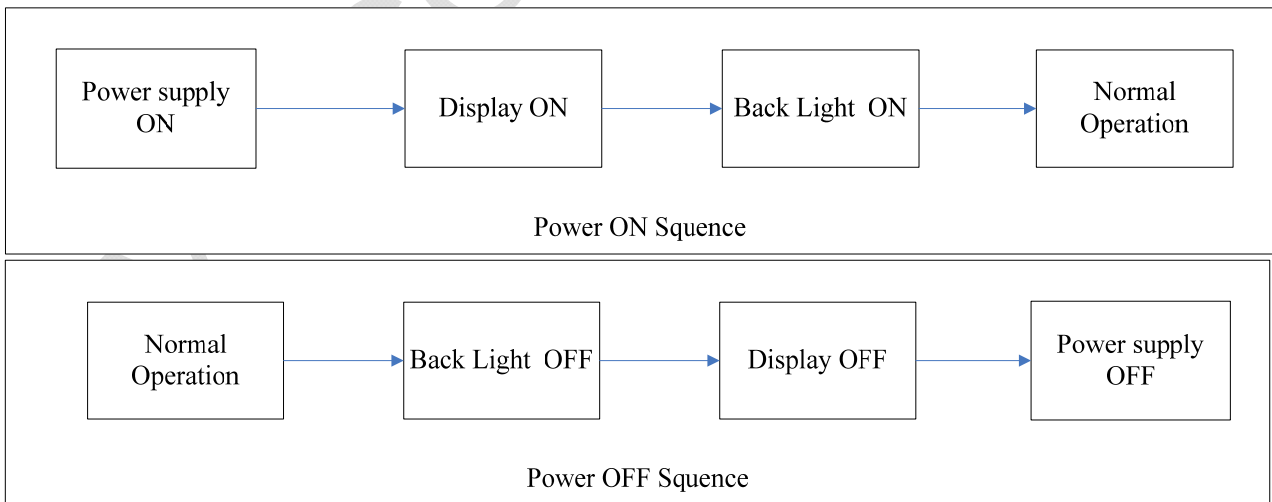
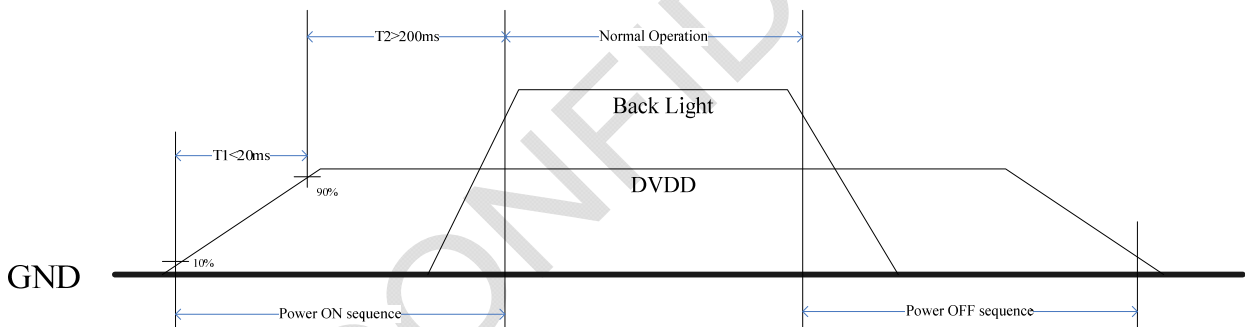



## 6 Optical Characteristics

Ta=25°C

Item	Symbol	Condition	Min	Typ	Max	Unit	Remark	
View Angles	$\theta T$	$CR \geq 10$	50	60	-	Degree	Note 2	
	$\theta B$		60	70	-			
	$\theta L$		60	70	-			
	$\theta R$		60	70	-			
Contrast Ratio	CR	$\theta=0^\circ$	400	500	-		Note1 Note3	
Response Time	$T_{ON}$	25°C	-	25	40	ms	Note1	
	$T_{OFF}$						Note4	
Chromaticity	White	Backlight is on	x	0.260	0.310	0.360		Note1 Note5
			y	0.280	0.330	0.380		
	Red		x	0.548	0.598	0.648		
			y	0.296	0.346	0.396		
	Green		x	0.289	0.339	0.389		
			y	0.538	0.588	0.638		
	Blue		x	0.097	0.147	0.197		
			y	0.046	0.096	0.146		
Uniformity	U		70	75	-	%	Note1 Note6	
NTSC			-	50	-	%	Note 5	
Luminance	L		200	250	-	cd/m <sup>2</sup>	Note1 Note7	

Test Conditions:

1.  $I_F=20\text{ mA}$ ,  $V_F=9.6\text{ V}$  and the ambient temperature is 25°C.
2. The test systems refer to Note 1 and Note 2.



Note 1: Definition of optical measurement system.

The optical characteristics should be measured in dark room. After 5 Minutes operation, the optical properties are measured at the center point of the LCD screen. All input terminals LCD panel must be ground when measuring the center area of the panel.

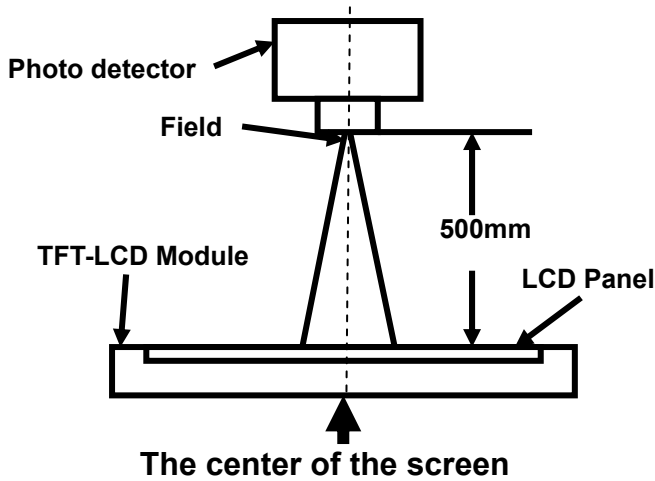

Item	Photo detector	Field
Contrast Ratio	BM-5A	1°
Luminance		
Lum Uniformity		
Chromaticity	SR-3A	
Response Time	TRD100	-

Note 2: Definition of viewing angle range and measurement system.

viewing angle is measured at the center point of the LCD by CONOSCOPE(ergo-80).

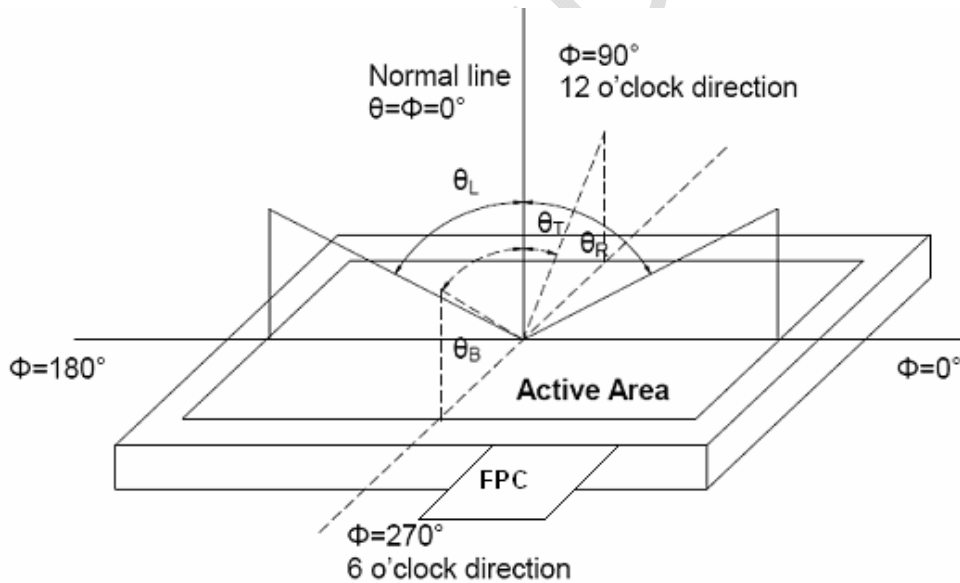

Note 3: Definition of contrast ratio

$$\text{Contrast ratio (CR)} = \frac{\text{Luminance measured when LCD is on the "White" state}}{\text{Luminance measured when LCD is on the "Black" state}}$$

“White state “: The state is that the LCD should drive by Vwhite.

“Black state” : The state is that the LCD should drive by Vblack.

Vwhite: To be determined    Vblack: To be determined.

Note 4: Definition of Response time



The response time is defined as the LCD optical switching time interval between “White” state and “Black” state. Rise time ( $T_{ON}$ ) is the time between photo detector output intensity changed from 90% to 10%. And fall time ( $T_{OFF}$ ) is the time between photo detector output intensity changed from 10% to 90%.

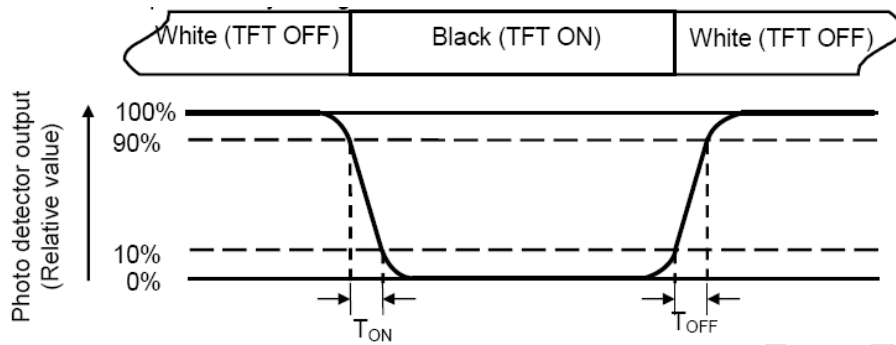

Note 5: Definition of color chromaticity (CIE1931)

Color coordinates measured at center point of LCD.

Note 6: Definition of Luminance Uniformity

Active area is divided into 9 measuring areas (Refer Fig. 2). Every measuring point is placed at the center of each measuring area.

$$\text{Luminance Uniformity (U)} = L_{\min} / L_{\max}$$

L-----Active area length W----- Active area width

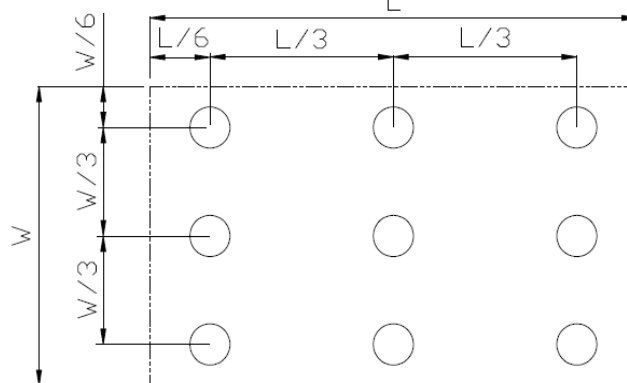

$L_{\max}$ : The measured Maximum luminance of all measurement position.

$L_{\min}$ : The measured Minimum luminance of all measurement position.

Note 7: Definition of Luminance:

Measure the luminance of white state at center point.



**7 Environmental / Reliability Test**

No	Test Item	Condition	Remarks
1	High Temperature Operation	Ts = +70°C, 240 hours	IEC60068-2-1:2007 GB2423.2-2008
2	Low Temperature Operation	Ta = -20°C, 240 hours	IEC60068-2-1:2007 GB2423.1-2008
3	High Temperature Storage	Ta = +80°C, 240 hours	IEC60068-2-1:2007 GB2423.2-2008
4	Low Temperature Storage	Ta = -30°C, 240 hours	IEC60068-2-1:2007 GB2423.1-2008
5	Storage at High Temperature and Humidity	Ta = +60°C, 90% RH max,240hours	IEC60068-2-78 :2001 GB/T2423.3—2006
6	Thermal Shock (non-operation)	-30°C 30 min~+80°C 30 min, Change time:5min, 20 Cycle	Start with cold temperature, End with high temperature, IEC60068-2-14:1984,G B2423.22-2002
7	ESD	C=150pF,R=330Ω,5point/panel Air:±8Kv,5times; Contact:±4Kv,5times (Environment:15°C~35°C, 30%~60%.86Kpa~106Kpa)	IEC61000-4-2:2001 GB/T17626.2-2006
8	Vibration Test	Frequency range:10~55Hz Stroke:1.5mm Sweep:10Hz~55Hz~10Hz 2 hours for each direction of X.Y.Z. (6 hours for total)	IEC60068-2-6:1982 GB/T2423.10—1995
9	Mechanical Shock (Non Op)	Half Sine Wave 60G 6ms, ±X,±Y,±Z 3times for each direction	IEC60068-2-27:1987 GB/T2423.5—1995
10	Package Drop Test	Height:60cm, 1corner,3edges,6surfaces	IEC60068-2-32:1990 GB/T2423.8—1995

Note1: Ts is the temperature of panel's surface.

Note2: Ta is the ambient temperature of samples.



8 Mechanical Drawing

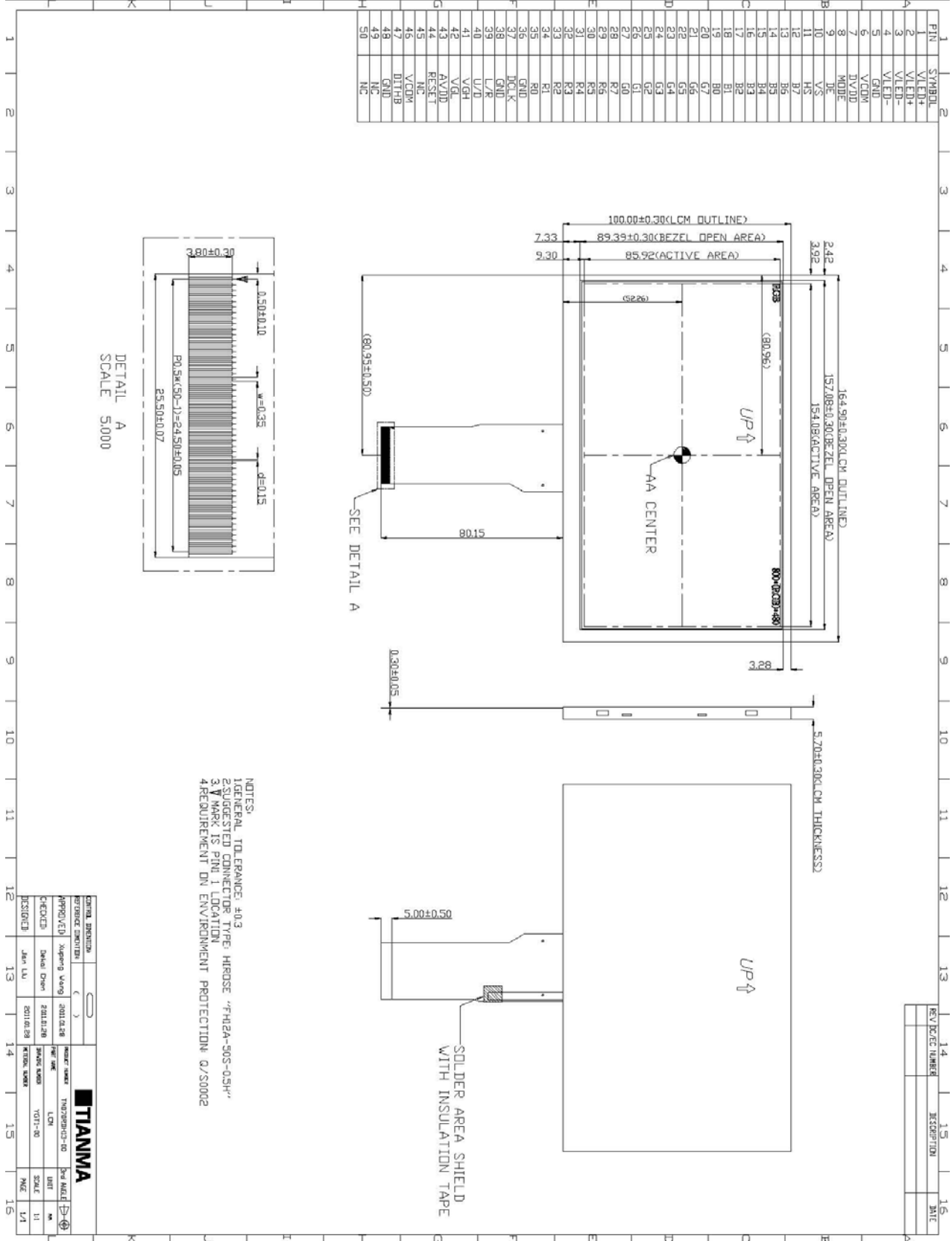

The information contained herein is the exclusive property of SHANGHAI AVIC OPTOELECTRONICS Corporation, and shall not be distributed, reproduced, or disclosed in whole or in part without prior written permission of SHANGHAI AVIC OPTOELECTRONICS Corporation.



### 9 Packing drawing

NO	Item	Model (material)	Dimensions(mm)	Unit Weight(Kg)	Quantity	Remark	
1	LCM Module	TM070RDH13	164.9×100.0×5.7	0.16	50		
2	Partition_1	Corrugated paper	513×333×215	1.571	1		
3	Anti-static Bag	PE	180×160×0.05	0.001	50	Anti-static	
4	Dust-Proof Bag	PE	700×530	0.06	1		
5	Partition_2	Corrugated Paper	505×332×4.0	0.098	2		
6	Corrugated Bar	Corrugated Paper	513×146×19.5	0.057	4		
7	Carton	Corrugated Paper	530×350×250	1.12	1		
8	Model Label		35×15	0.001	1		
9	Total Weight	11.226±5%					

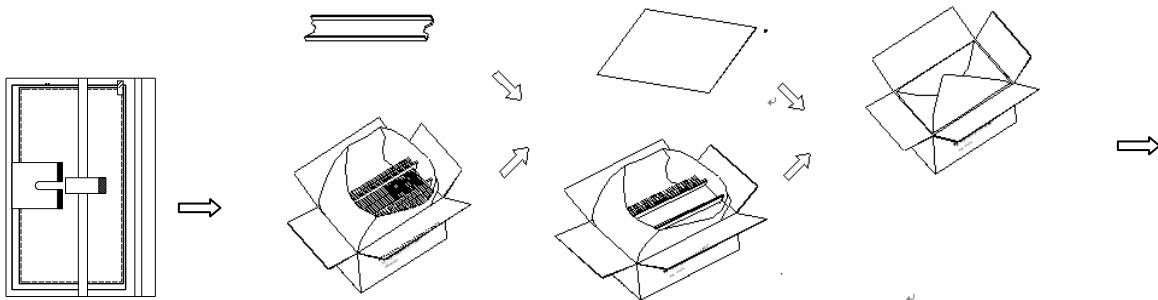

LCM module

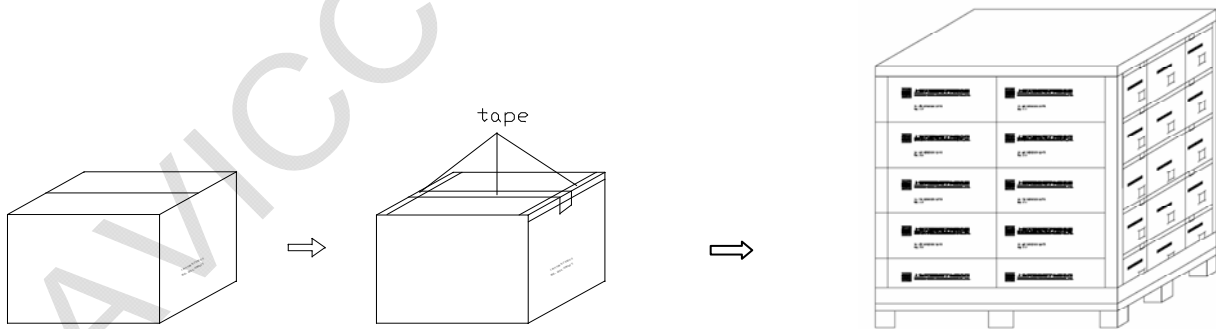



## 10 Precautions for Use of LCD Modules

### 10.1 Handling Precautions

10.1.1 The display panel is made of glass. Do not subject it to a mechanical shock by dropping it from a high place, etc.

10.1.2 If the display panel is damaged and the liquid crystal substance inside it leaks out, be sure not to get any in your mouth, if the substance comes into contact with your skin or clothes, promptly wash it off using soap and water.

10.1.3 Do not apply excessive force to the display surface or the adjoining areas since this may cause the color tone to vary.

10.1.4 The polarizer covering the display surface of the LCD module is soft and easily scratched. Handle this polarizer carefully.

10.1.5 If the display surface is contaminated, breathe on the surface and gently wipe it with a soft dry cloth. If still not completely clear, moisten cloth with one of the following solvents:

- Isopropyl alcohol
- Ethyl alcohol

Solvents other than those mentioned above may damage the polarizer. Especially, do not use the following:

- Water
- Ketone
- Aromatic solvents

10.1.6 Do not attempt to disassemble the LCD Module.

10.1.7 If the logic circuit power is off, do not apply the input signals.

10.1.8 To prevent destruction of the elements by static electricity, be careful to maintain an optimum work environment.

10.1.8.1 Be sure to ground the body when handling the LCD Modules.

10.1.8.2 Tools required for assembly, such as soldering irons, must be properly ground.

10.1.8.3 To reduce the amount of static electricity generated, do not conduct assembly and other work under dry conditions.

10.1.8.4 The LCD Module is coated with a film to protect the display surface. Be care when peeling off this protective film since static electricity may be generated.

### 10.2 Storage precautions

10.2.1 When storing the LCD modules, avoid exposure to direct sunlight or to the light of fluorescent lamps.

10.2.2 The LCD modules should be stored under the storage temperature range. If the LCD modules will be stored for a long time, the recommend condition is:

Temperature : 0°C ~ 40°C      Relatively humidity: ≤80%

10.2.3 The LCD modules should be stored in the room without acid, alkali and harmful gas.

### 10.3 Transportation Precautions

10.3.1 The LCD modules should be no falling and violent shocking during transportation, and also should avoid excessive press, water, damp and sunshine.