

MODEL NO. : TM104SDH03
ISSUED DATE: 2014-07-08
VERSION : Ver 2.3

- Preliminary Specification
 Final Product Specification

Customer : _____

Approved by	Notes

TIANMA Confirmed :

Prepared by	Checked by	Approved by
Rui Xu		Longping Deng

This technical specification is subjected to change without notice

Table of Contents

Coversheet	1
Table of Contents	2
Record of Revision.....	3
1 General Specifications.....	4
2 Input/Output Terminals	5
3 Absolute Maximum Ratings.....	8
4 Electrical Characteristics	9
5 Timing Chart.....	12
6 Optical Characteristics	15
7 Environmental / Reliability Test.....	20
8 Mechanical Drawing	21
9 Packing Drawing	22
10 Precautions For Use of LCD Modules	24

TIANMA CONFIDENTIAL

Record of Revision

Rev	Issued Date	Description	Editor
1.0	2010-04-20	Preliminary Release	Xing Nie
1.1	2010-06-28	Mechanical Drawing	Xing Nie
1.2	2010-08-30	Revise driving TFT LCD Panel & Driving Backlight	Xing Nie
1.3	2011-02-22	Final Product Specification Release	Xing Nie
1.4	2012-01-12	Updated Input/Output Terminals ,Absolute Maximum Ratings and ElectricalCharacteristics	Pingping Wang
2.0	2012-02-27	Final SPEC Release	longping.Deng
2.1	2014-01-21	Revise Color Depth	longping.Deng
2.2	2014-02-17	Revise VIH in 4.2	Wallace.Jiang
2.3	2014-07-08	Revise the timing chart on page 10	Rui Xu

1 General Specifications

	Feature	Spec
Display Spec.	Size	10.4 inch
	Resolution	800(RGB) x 600
	Technology Type	a-Si
	Pixel Configuration	R.G.B. Vertical Stripe
	Pixel pitch(mm)	0.264x0.264
	Display Mode	TM with Normally White
	Surface Treatment	Anti-Glare(3H)
	Viewing Direction	12 o'clock
	Gray Scale Inversion Direction	6 o'clock
Mechanical Characteristics	LCM (W x H x D) (mm)	243.00x179.40x8.5 (Max)
	Active Area(mm)	211.20x158.40
	With /Without TSP	Without TSP
	CN1 Match Connection Type	DF19G-20S-1C
	CN2 Match Connection Type	H208K-P05N-02B (ENTERY)
	Weight (g)	432.89
Electrical Characteristics	Interface	LVDS 8-bit/6-bit
	Color Depth	16.2M/262K
	Driver IC	NT39411B+NT39211

Note 1: Viewing direction for best image quality is different from TFT definition, there is a 180 degree shift.

Note 2 : Requirements on Environmental Protection: Q/S0002

Note 3 : LCM weight tolerance : +/- 5%

2 Input/Output Terminals

2.1 TFT LCD Panel

CN1 Connector type: 107A20-0021RA-G3-R

No	Symbol	I/O	Description	Comment
1	VDD	P	Power Supply	
2	VDD	P	Power Supply	
3	GND	P	Ground	
4	DPS	I	Reverse Scan Function [H: Enable; L: Disable]	Note3
5	RxIN0-	I	LVDS receiver signal channel 0. LVDS Differential Data Input (R0, R1, R2, R3, R4, R5, G0)	Note2
6	RxIN0+	I		
7	GND	P	Ground	
8	RxIN1-	I	LVDS receiver signal channel 1. LVDS Differential Data Input (G1, G2, G3, G4, G5, B0, B1)	Note2
9	RxIN1+	I		
10	GND	P	Ground	
11	RxIN2-	I	LVDS receiver signal channel 2 LVDS Differential Data Input (B2, B3, B4, B5, DE)	Note2
12	RxIN2+	I		
13	GND	P	Ground	
14	RxCLKIN-	I	LVDS receiver signal clock	Note2
15	RxCLKIN+	I		
16	GND	P	Ground	
17	RxIN3-	I	LVDS receiver signal channel 3, NC for 6-bit LVDS Input. LVDS Differential Data Input (R6, R7, G6, G7, B6, B7, RSV) for 8-bit LVDS input.	Note2
18	RxIN3+	I		
19	AGMode	I	Aging Mode setting [H: Aging Mode; L: Normal]	
20	SEL68	P	6-bit/8-bit LVDS data input selection [H: 8-bit L: 6-bit]	Note2

P: Power/GND; I: input pin;

Table 2.1 input terminal pin assignment

Note1: CN1 Match Connector type: DF19G-20S-1C or compatible

Note2: LVDS 6-bit data mapping when SEL68=L as follows:

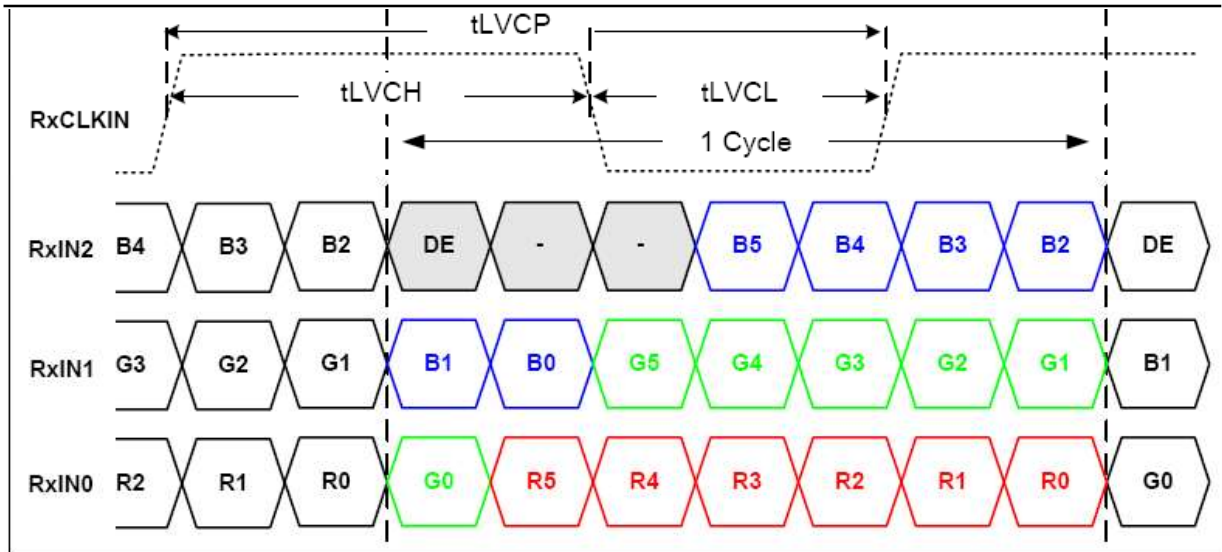

Figure 2.1.1 Input signal data mapping

LVDS 8-bit data mapping when SEL68=H as follows:

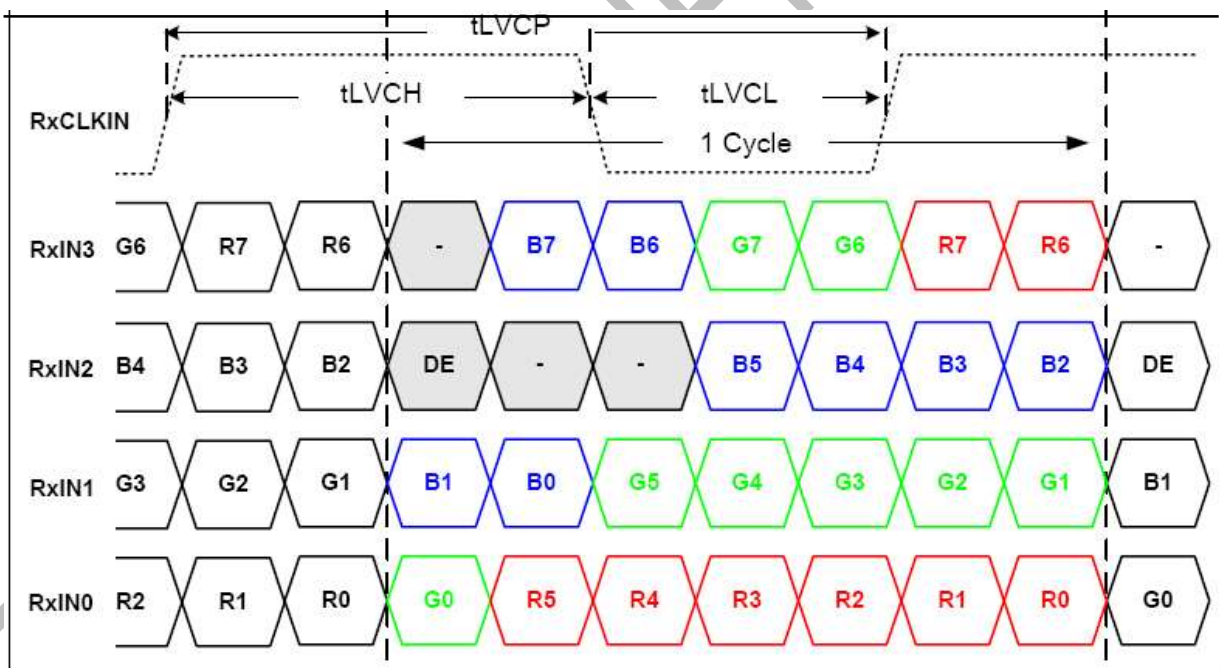

Figure 2.1.2 Input signal data mapping

Note3: DPS: Scan direction setting

DPS	Horizontal Scan direction	Vertical Scan direction
High	Right to left	Down to up
Low	Left to right	Up to down

2.2 CN2(Backlight Connector)

Connector type: 3808K-F05N-03R (ENTERY)

No	Symbol	I/O	Description	Remark
1	VCC	P	Power for LED driving circuit.12.0V input.	Note 1
2	PGND	P	Ground for LED driving circuit. 0V input.	
3	EN	I	Backlight enable setting. High: enabled; Low: disable.	Note2
4	Dimming	I	PWM signal for adjusting luminance of backlight.	
5	NC	-	No connection	

Note1: Because of the in-rush current at the moment of power-on,so should ensure the current of VCC could supply 1A current at the moment of the power-on.

Note2: Should Keep En & Dimming both High when power on,and after 500ms ,then input the PWM signal.

Match connector: H208K-P05N-02B (ENTERY)

TIANMA CONFIDENTIAL

3 Absolute Maximum Ratings

3.1 Driving TFT LCD Panel

GND=0V, Ta = 25°C

Item	Symbol	Min	Max	Unit	Remark
Power Voltage	VDD	-0.3	5.0	V	
Power for LED driving circuit	VCC	-0.3	13.5	V	
Input voltage	V _{IN}	-0.3	5.0	V	Note1
Input voltage for backlight	V _t	-0.5	5.0	V	Note2; Note3
Operating Temperature	T _{OPR}	-30	80	°C	
Storage Temperature	T _{STG}	-30	85	°C	

Note1: V_{IN} represents RxIN0±, RxIN1±, RxIN2±, RxIN3±, RxCLKIN±, DPS, AGMode, SEL68.

Note2: V_t represents EN and Dimming.

Note3: Should keep the maximum value of EN and Dimming are equal.

TIANMA CONFIDENTIAL

4 Electrical Characteristics

4.1 Driving TFT LCD Panel

GND=0V, Ta=25°C

Item	Symbol	Min	Typ	Max	Unit	Remark
Supply Voltage	VDD	3.0	3.3	3.6	V	
Power Supply Ripple Voltage	V _{RP_VDD}			100	mV	
Rush Current	I _{rush_VDD}		1.6	2.0	A	
LVDS Differential input high threshold	V _{TH}	-	-	+100	mV	V _{CMLVDS} =1.2V
LVDS Differential input low threshold	V _{TL}	-100	-	-	mV	V _{CMLVDS} =1.2V
Differential input voltage	V _{ID}	0.1	-	0.6	V	
LVDS input common mode voltage	V _{CMLVDS}	V _{ID} /2	-	1.4-(V _{ID} /2)	V	
Common Electrode Driving Signal	VCOM	-	4.30	-	V	Note1
Sync Frequency	FVD	-	60	70	Hz	
VDD Power Consumption	I _{VDD}	-	340	380	mA	Note2

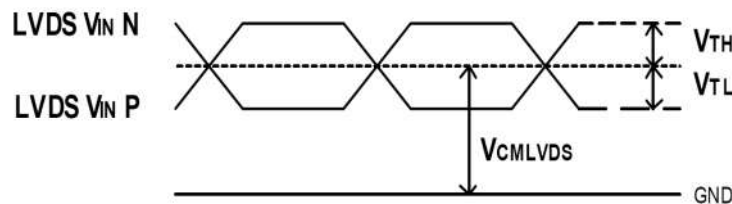

Figure 4.1.1 LVDS DC timing diagram

Note1: For different LCM, the value may have a bit of difference.

Note2: To test the current dissipation, use "all Black Pattern" test pattern. Because of the in-rush current at the moment of the power-on, so should ensure the VDD power supplier could supply at least 1.5A current at the moment of power-on.

4.2 Driving Backlight

Ta=25°C

Item	Symbol	Min	Typ	Max	Unit	Remark
Power for LED driving circuit	VCC	10.8	12.0	12.6	V	
Current of Backlight Power	I _{VCC}	-	0.32	-	A	100% PWM Duty Note1
Rush Current	I _{rush_VCC}		0.6	1.0	A	
Backlight Power Consumption	W _{BL}	-	3.84	-	W	100% PWM Duty
Dimming Frequency	F _{PWM}	200	-	20K	Hz	
Dimming duty cycle	-	0	-	100%	-	
High Level Input Voltage	V _{IH}	2	-	5	V	For Dimming, EN pin
Low Level Input Voltage	V _{IL}	-	-	0.8	V	For Dimming, EN pin
LED Life Time	-	25000	(50000)	-	hrs	Note 1

Note1: Optical performance should be evaluated at Ta=25°C only.

If LED is driven by high current, high ambient temperature & humidity condition, the life time of LED will be reduced.

Operating life means brightness goes down to 50% initial brightness.

Typical operating life time is estimated data.

Remark:The timing sequence of back light power-on as following:

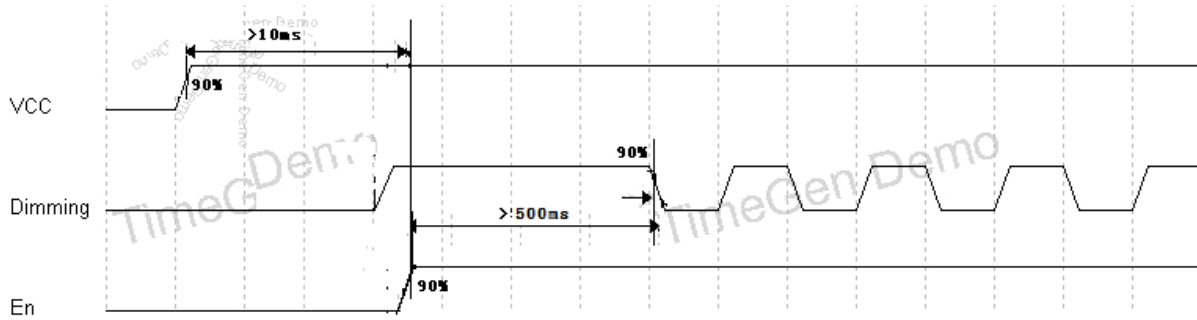

TIANMA CONFIDENTIAL

4.3 Block Diagram

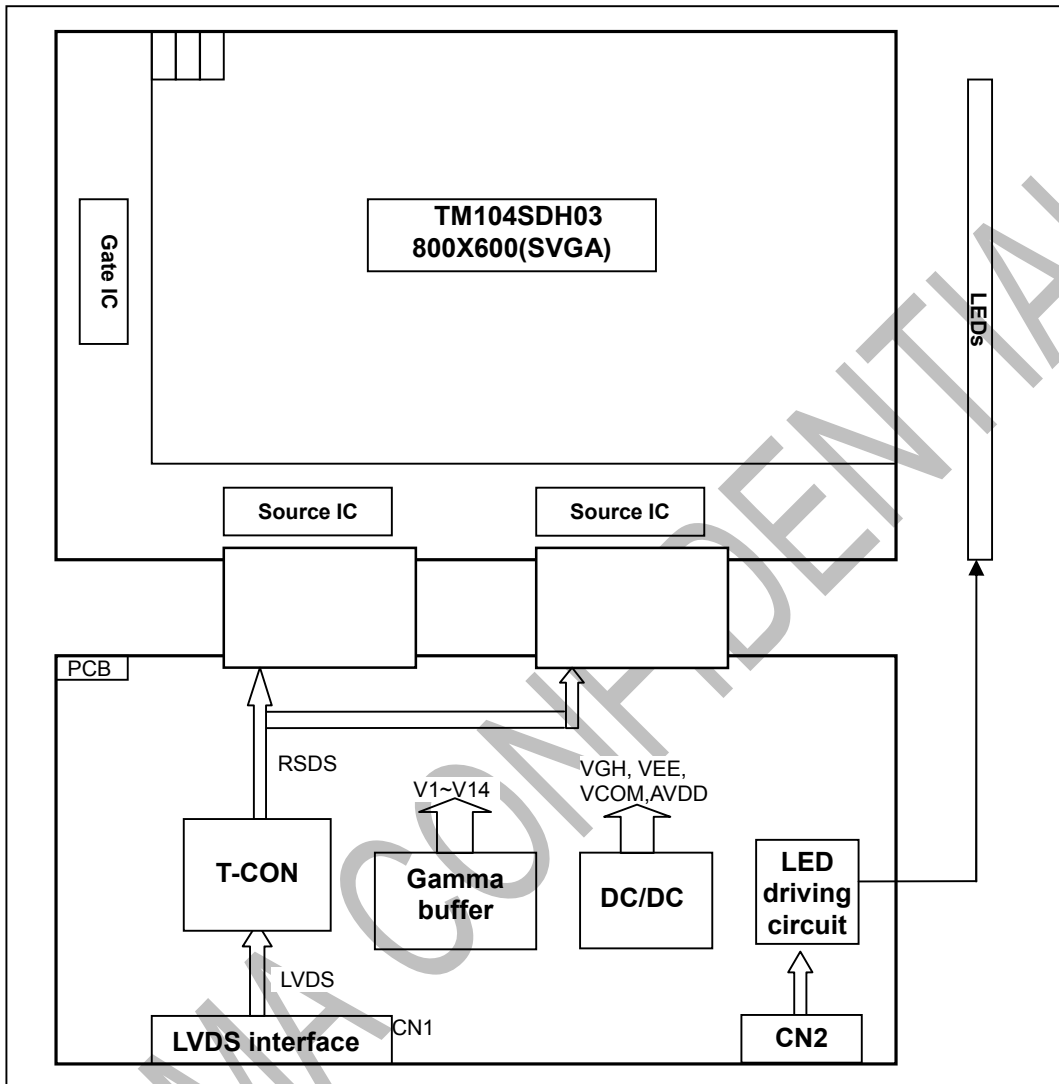

5 Timing Chart

5.1 Timing Parameter

Item	Symbol	Min	Typ	Max	Unit	Condition
Clock period	tLVCP	20.0	25	31.25	ns	
Clock high time	tLVCH	-	14.29	-	ns	
Clock low time	tLVCL	-	10.71	-	ns	
PLL wake-up time	tLVPLL	-	-	1	ms	
Input skew margin	tLVSKM	400	-	-	ps	f=85MHz

Table 5.1 timing parameter

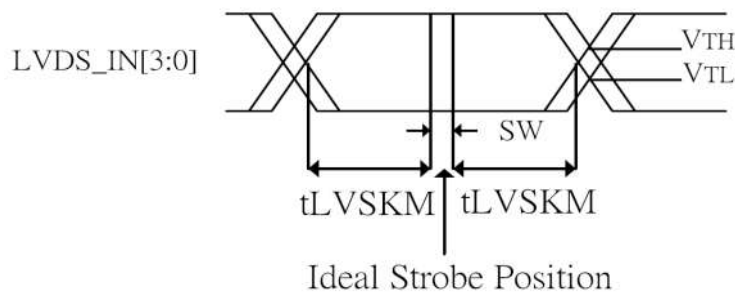
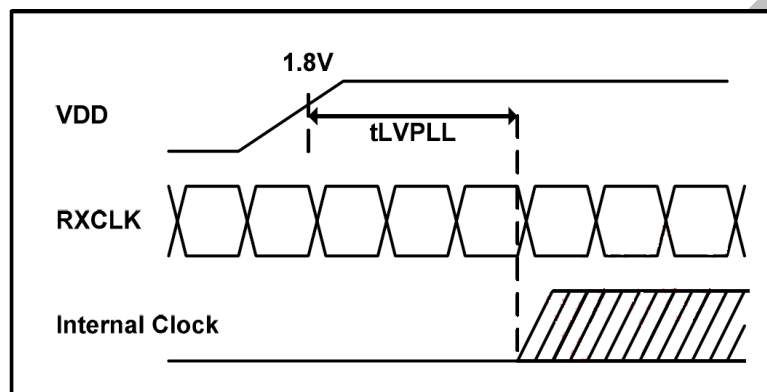

Ideal Strobe Position

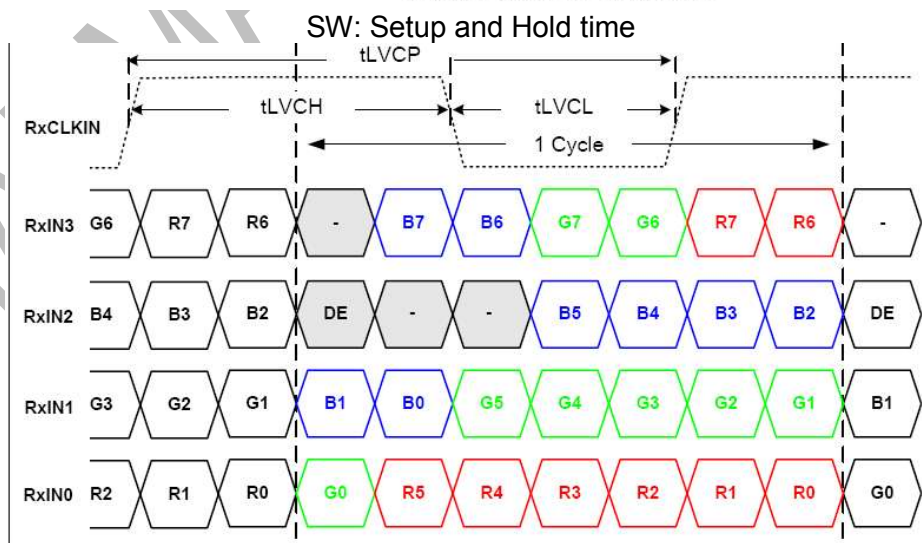

Figure 5.1 Input signal data timing

5.2 Power On/Off Sequence

Item	Symbol	Min	Typ	Max	Unit	Remark
VDD 3.0V to signal starting	Tp1	5	-	50	ms	
Signal starting to backlight on	Tp2	150	-	-	ms	
Signal off to VDD 3.0V	Tp3	5	-	50	ms	
Backlight off to signal off	Tp4	150	-	-	ms	
VDD rise time	Tr	0.1	-	5	ms	

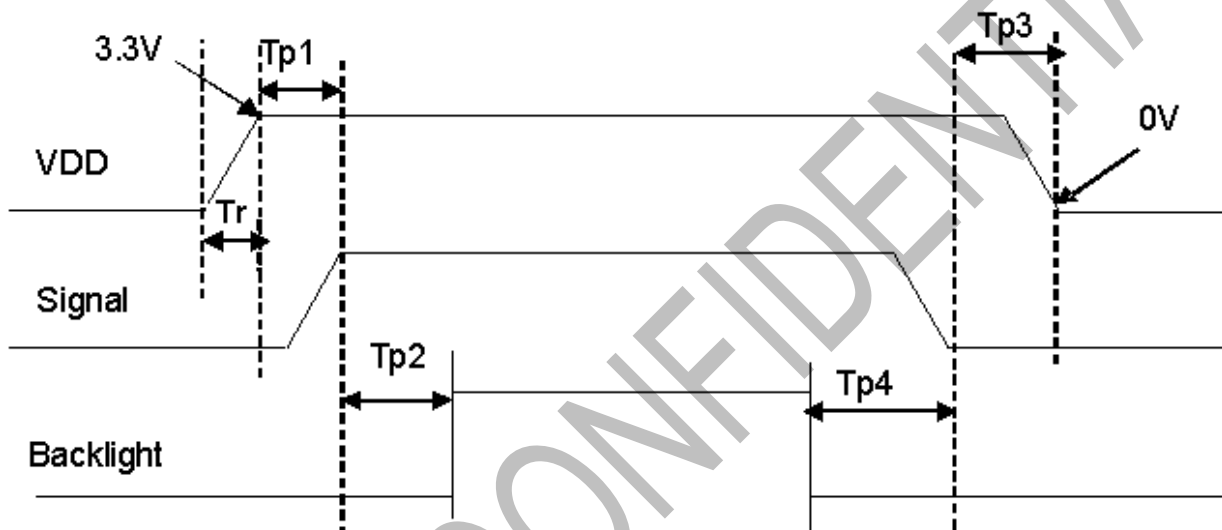

Figure 5.2 Interface power on/off sequence

5.3 Recommended Input Timing of LVDS transmitter

	Parameter	Symbol	Min.	Typ.	Max.	Unit	Remarks
Dclk frequency		1/Tclk	32	40	50	MHz	
Horizontal section	Horizontal total	Th	866	1056	1064	Tclk	
	Horizontal blanking	Thb	66	256	264	Tclk	
	Valid Data Width	Thd	800	800	800	Tclk	
Vertical section	Frame rate	-	-	60	70	Hz	
	Vertical total	Tv	604	628	800	Th	
	Vertical blanking	Tvb	4	28	200	Th	
	Valid Data Width	Tvd	600	600	600	Th	

Note: DE signal is necessary.

Input Timing Control Conditions

The information contained herein is the exclusive property of SHANGHAI TIANMA MICRO-ELECTRONICS Corporation, and shall not be distributed, reproduced, or disclosed in whole or in part without prior written permission of SHANGHAI TIANMA MICRO-ELECTRONICS Corporation.

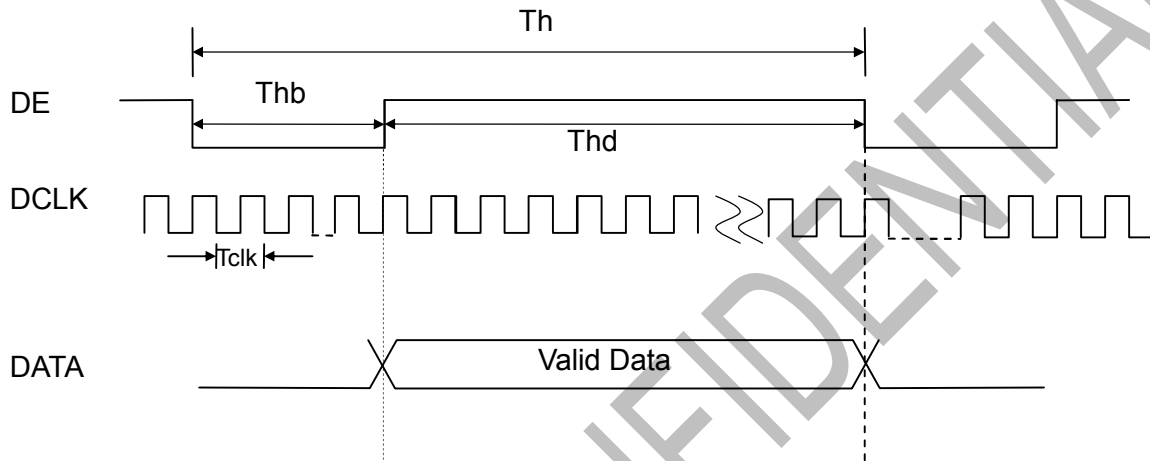
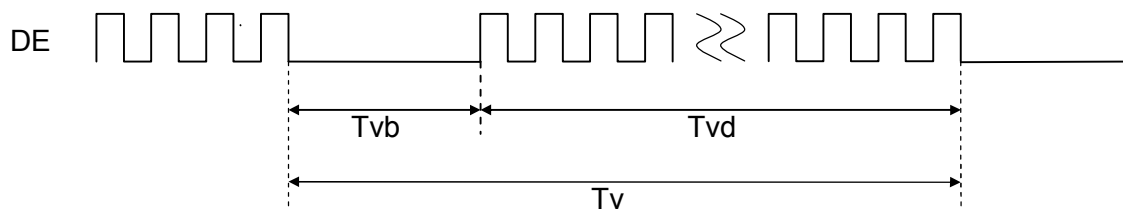

6 Optical Characteristics

6.1 Optical Specification

Ta=25°C

Item	Symbol	Condition	Min	Typ	Max	Unit	Remark	
View Angles	θT	$CR \geq 10$	50	60	-	Degree	Note 2	
	θB		60	70	-			
	θL		60	70	-			
	θR		60	70	-			
Contrast Ratio	CR	$\theta=0^\circ$	400	500	-	-	Note1 Note3	
Response Time	T_{ON}	25°C	-	10	15	ms	Note1	
	T_{OFF}		-	15	25		Note4	
Chromaticity	White	Backlight is on	x	0.2545	0.3045	0.3545	-	Note5 Note1
			y	0.2946	0.3446	0.3946		
	Red		x	0.5592	0.6092	0.6592		
			y	0.3052	0.3552	0.4052		
	Green		x	0.2649	0.3149	0.3649		
			y	0.5053	0.5553	0.6053		
	Blue		x	0.0897	0.1367	0.1897		
			y	0.0896	0.1396	0.1896		
Uniformity	U	-	70	80	-	%	Note1 Note6	
NTSC	-	-	-	50	-	%	Note 5	
Luminance	L		280	350	-	cd/m ²	Note1 Note7	

Test Conditions:

1. The ambient temperature is 25±2°C.humidity is 65±7%
2. The test systems refer to Note 1 and Note 2.

Note 1: Definition of optical measurement system.

The optical characteristics should be measured in dark room. After 5 minutes operation, the optical properties are measured at the center point of the LCD screen. All input terminals LCD panel must be ground when measuring the center area of the panel.

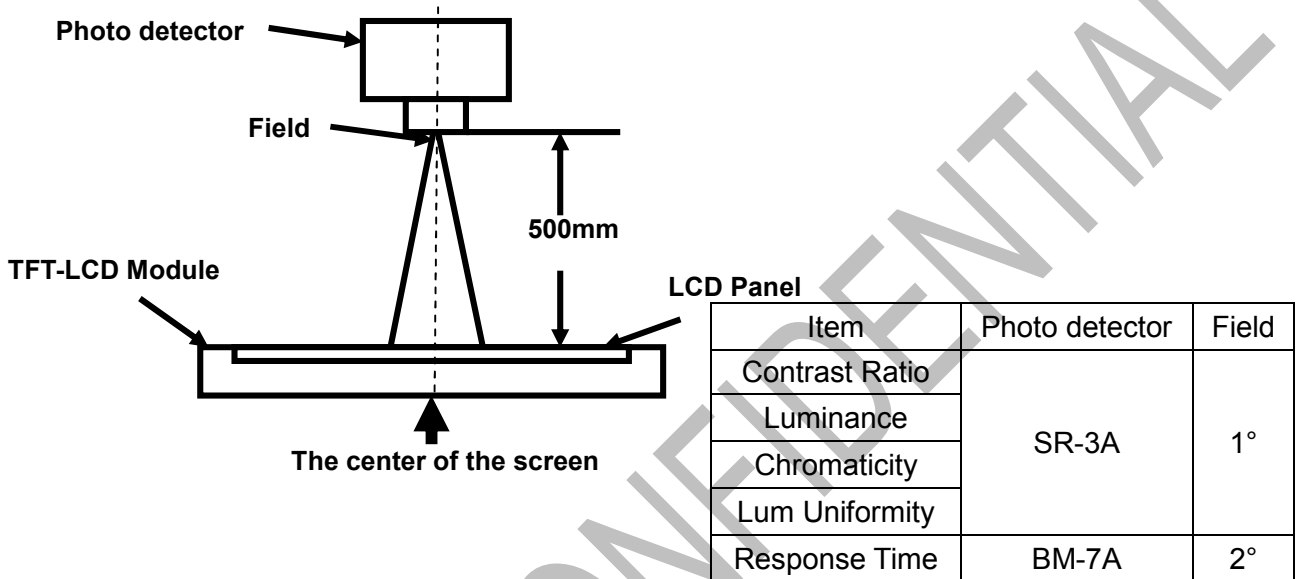

Note 2: Definition of viewing angle range and measurement system.

viewing angle is measured at the center point of the LCD by CONOSCOPE(ergo-80).

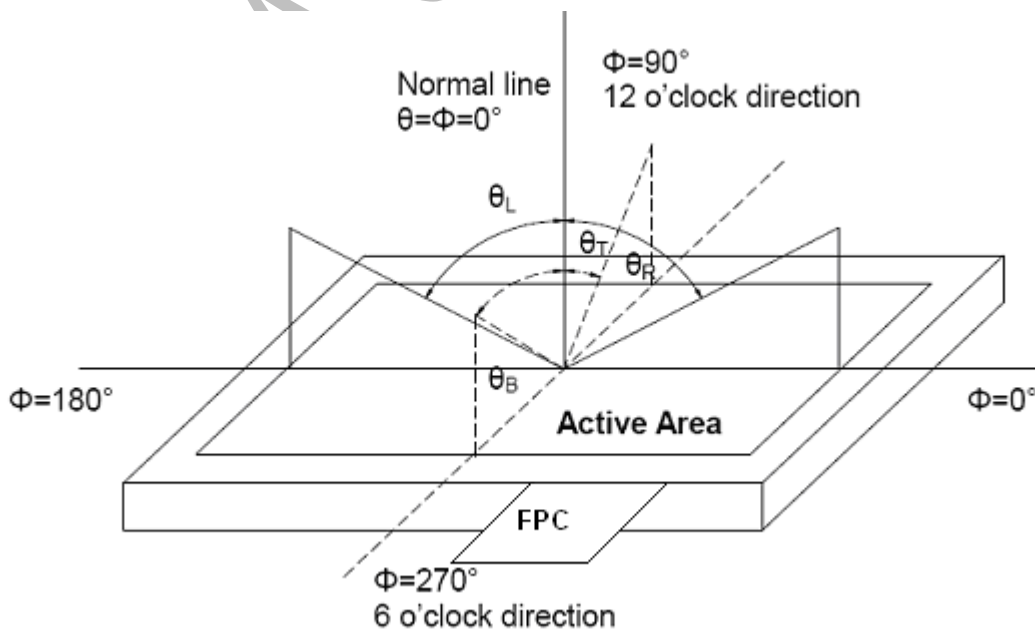

Fig. 1 Definition of viewing angle

The information contained herein is the exclusive property of SHANGHAI TIANMA MICRO-ELECTRONICS Corporation, and shall not be distributed, reproduced, or disclosed in whole or in part without prior written permission of SHANGHAI TIANMA MICRO-ELECTRONICS Corporation.

Note 3: Definition of contrast ratio

$$\text{Contrast ratio (CR)} = \frac{\text{Luminance measured when LCD is on the "White" state}}{\text{Luminance measured when LCD is on the "Black" state}}$$

“White state “:The state is that the LCD should driven by Vwhite.

“Black state”: The state is that the LCD should driven by Vblack.

Vwhite: To be determined Vblack: To be determined.

Note 4: Definition of Response time

The response time is defined as the LCD optical switching time interval between “White” state and “Black” state. Rise time (TON) is the time between photo detector output intensity changed from 90% to 10%. And fall time (TOFF) is the time between photo detector output intensity changed from 10% to 90%.

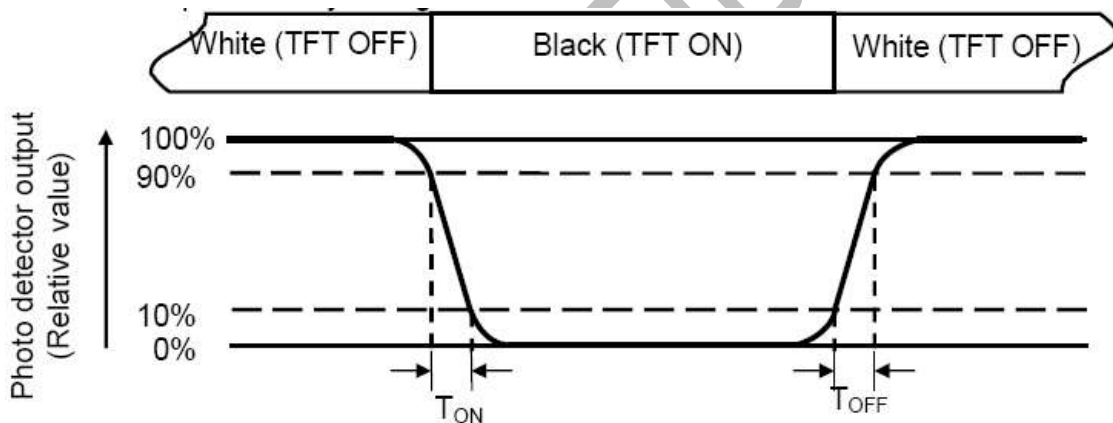

Note 5: Definition of color chromaticity (CIE1931)

Color coordinates measured at center point of LCD.

Note 6: Definition of Luminance Uniformity

Active area is divided into 9 measuring areas (Refer Fig. 2). Every measuring point is placed at the center of each measuring area.

$$\text{Luminance Uniformity}(U) = L_{\min} / L_{\max}$$

L-----Active area length W----- Active area width

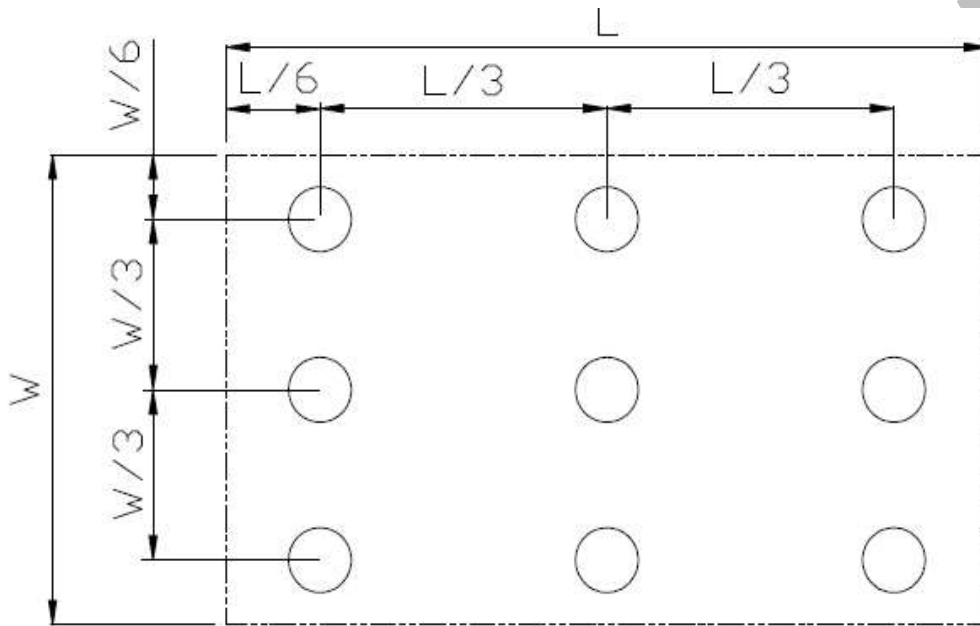

Fig. 2 Definition of uniformity

L_{\max} : The measured maximum luminance of all measurement position.

L_{\min} : The measured minimum luminance of all measurement position.

Note 7: Definition of Luminance :

Measure the luminance of white state at center point.

7 Environmental / Reliability Test

No	Test Item	Condition	Remark
1	High Temperature Operation	Ts=+80°C, 240hrs	Note1 IEC60068-2-1,GB2423.2
2	Low Temperature Operation	Ta=-30°C, 240hrs	IEC60068-2-1 GB2423.1
3	High Temperature Storage (non-operation)	Ta=+85°C, 240hrs	IEC60068-2-1 GB2423.2
4	Low Temperature Storage (non-operation)	Ta=-30°C, 240hrs	IEC60068-2-1 GB2423.1
5	High Temperature & High Humidity Operation	Ta = +60°C, 90% RH max,240 hours	Note2 IEC60068-2-78 GB/T2423.3
6	Thermal Shock (non-operation)	-30°C 30 min~+85°C 30 min, Change time:5min, 100 Cycles	Start with cold temperature, End with high temperature, IEC60068-2-14:1984,GB2423.22
7	Electro Static Discharge (operation)	C=150pF,R=330Ω, Air:±15Kv, Contact:±8Kv, 10times/terminal	IEC61000-4-2 GB/T17626.2
8	Vibration (non-operation)	Frequency range:10~55Hz, Stroke:1.5mm Sweep:10Hz~55Hz~10Hz 2hours for each direction of x.y.z (6 hours for total)	IEC60068-2-6 GB/T2423.10
9	Shock (non-operation)	80G 6ms, ±X,±Y,±Z 3 times for each direction	IEC60068-2-27 GB/T2423.5
10	Package Drop Test	Height:80 cm,1 corner, 3 edges, 6 surfaces	IEC60068-2-32 GB/T2423.8
11	Package Vibration Test	Random Vibration: 0.015GxG/Hz for 5-200Hz, -6dB/Octave from 200-500Hz 2 hours for each direction of X,Y,Z (6 hours for total)	IEC60068-2-34 GB/T2423.11

Note1: Ts is the temperature of panel's surface.

Note2: Ta is the ambient temperature of sample.

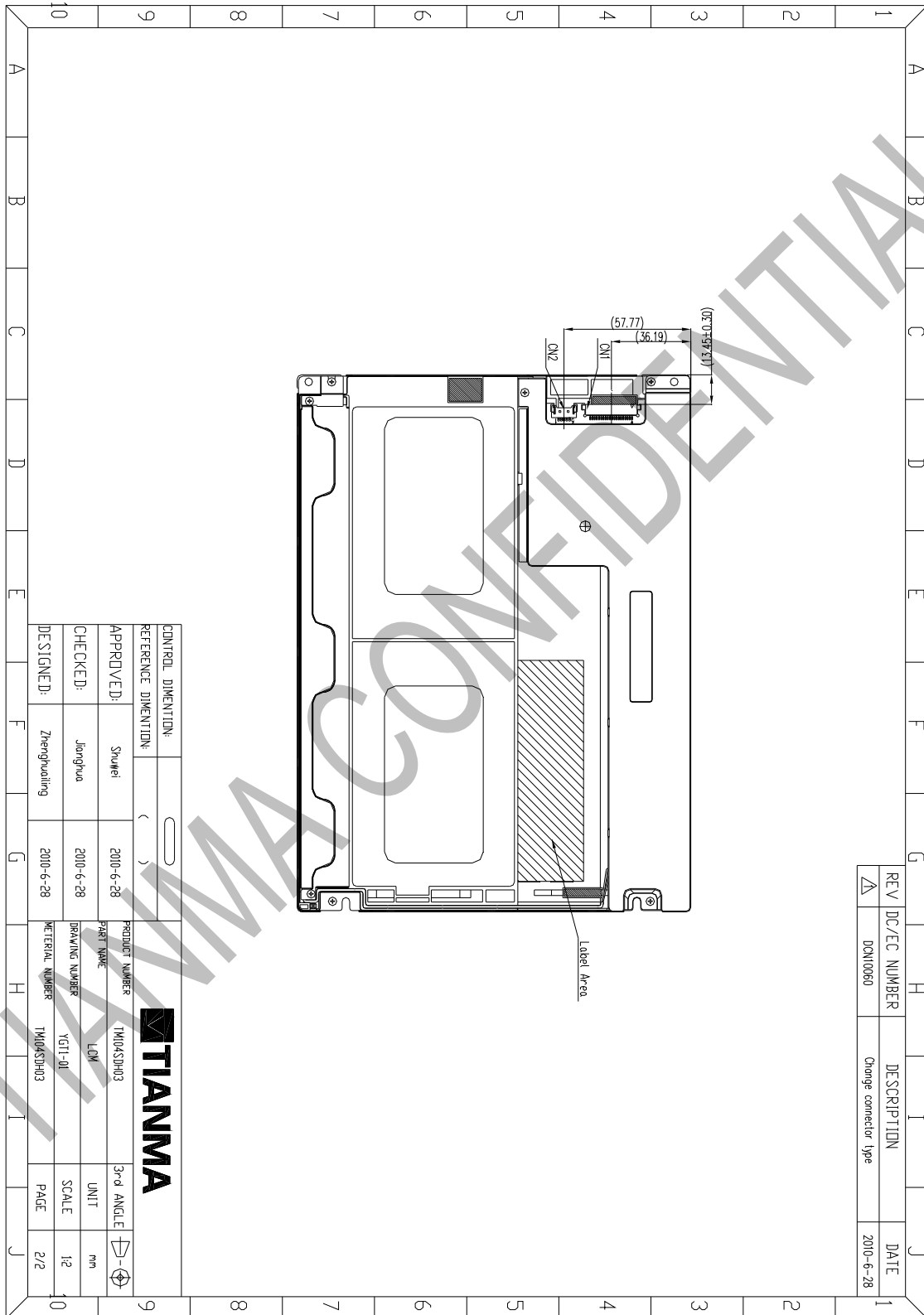
8 Mechanical Drawing

The information contained herein is the exclusive property of SHANGHAI TIANMA MICRO-ELECTRONICS Corporation, and shall not be distributed, reproduced, or disclosed in whole or in part without prior written permission of SHANGHAI TIANMA MICRO-ELECTRONICS Corporation.

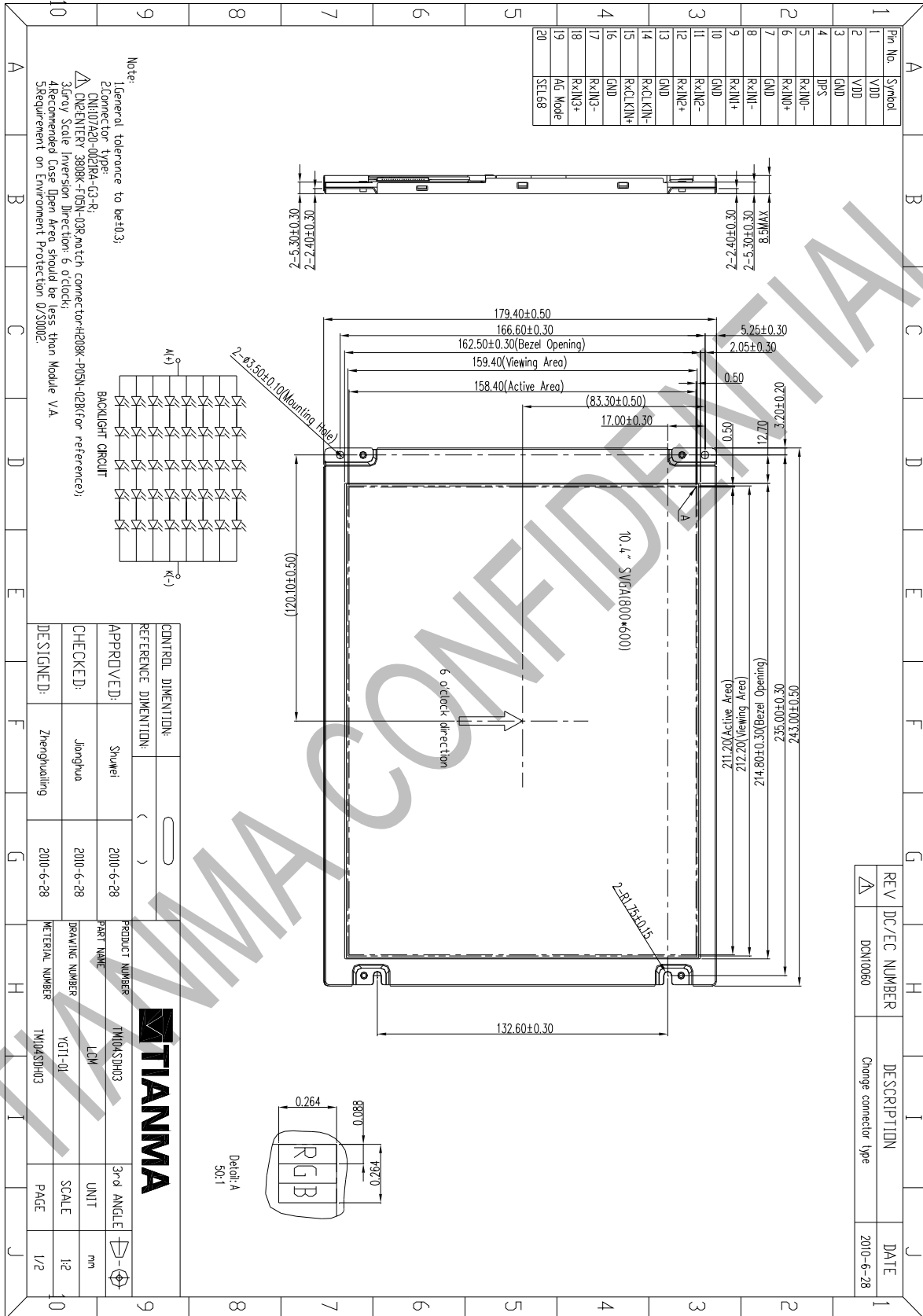

9 Packing Drawing

No	Item	Model (Material)	Dimensions(mm)	Unit Weight(Kg)	Quantity	Remark
1	LCM module	TM104SDH03	243.00x179.40x8.5 (Max)	0.433	20	
2	Partition_1	Corrugated Paper	513x333x217	1.47	1	
3	Anti-static Bag	PE	265×255×0.05	0.004	20	
4	DUST-PROOF BAG	PE	700×530	0.06	1	
5	Partition_2	Corrugated Paper	505x332 x4.0	0.1	1	
6	Corrugated Bar	Corrugated Paper	405 x292	0.1	1	
7	Carton	Corrugated Paper	530x350x250	1.12	1	
8	EPE	EPE	440x213 x4	1.02	1	
9	Total weight(Kg)	12.53±5%				

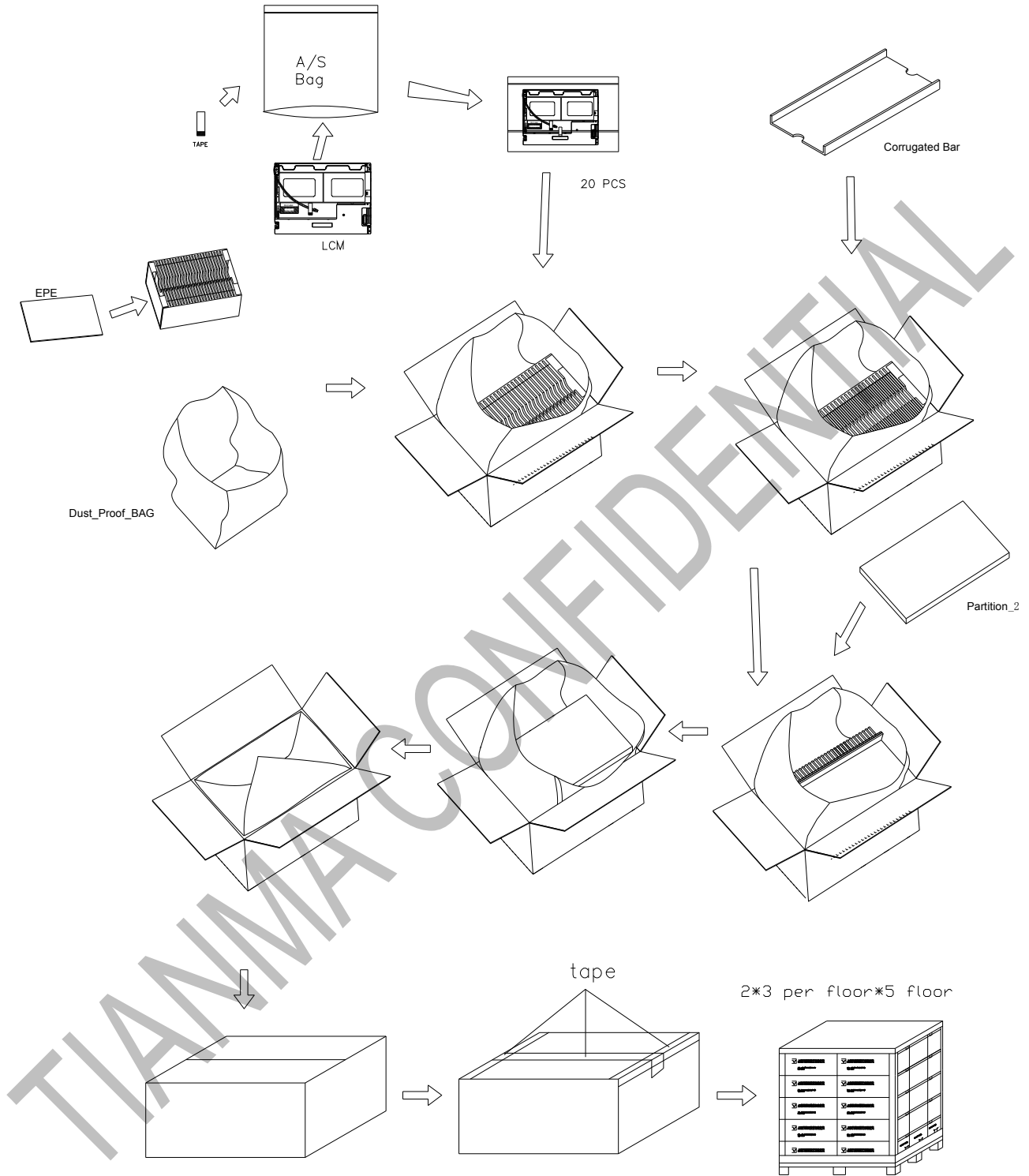

10 Precautions For Use of LCD Modules

10.1 Handling Precautions

- 10.1.1 The display panel is made of glass. Do not subject it to a mechanical shock by dropping it from a high place, etc.
- 10.1.2 If the display panel is damaged and the liquid crystal substance inside it leaks out, be sure not to get any in your mouth, if the substance comes into contact with your skin or clothes, promptly wash it off using soap and water.
- 10.1.3 Do not apply excessive force to the display surface or the adjoining areas since this may cause the color tone to vary.
- 10.1.4 The polarizer covering the display surface of the LCD module is soft and easily scratched. Handle this polarizer carefully.
- 10.1.5 If the display surface is contaminated, breathe on the surface and gently wipe it with a soft dry cloth. If still not completely clear, moisten cloth with one of the following solvents:
 - Isopropyl alcohol
 - Ethyl alcoholSolvents other than those mentioned above may damage the polarizer. Especially, do not use the following:
 - Water
 - Ketone
 - Aromatic solvents
- 10.1.6 Do not attempt to disassemble the LCD Module.
- 10.1.7 If the logic circuit power is off, do not apply the input signals.
- 10.1.8 To prevent destruction of the elements by static electricity, be careful to maintain an optimum work environment.
 - 10.1.8.1 Be sure to ground the body when handling the LCD Modules.
 - 10.1.8.2 Tools required for assembly, such as soldering irons, must be properly ground.
 - 10.1.8.3 To reduce the amount of static electricity generated, do not conduct assembly and other work under dry conditions.
 - 10.1.8.4 The LCD Module is coated with a film to protect the display surface. Be care when peeling off this protective film since static electricity may be generated.

10.2 Storage Precautions

- 10.2.1 When storing the LCD modules, avoid exposure to direct sunlight or to the light of fluorescent lamps.
- 10.2.2 The LCD modules should be stored under the storage temperature range. If the LCD modules will be stored for a long time, the recommend condition is:
Temperature : 0°C ~ 40°C Relatively humidity: ≤80%
- 10.2.3 The LCD modules should be stored in the room without acid, alkali and harmful gas.

10.3 Transportation Precautions

The LCD modules should be no falling and violent shocking during transportation, and also should avoid excessive press, water, damp and sunshine.