

TM 11-5820-472-12

DEPARTMENT OF THE ARMY TECHNICAL MANUAL

OPERATOR AND ORGANIZATIONAL MAINTENANCE MANUAL

RADIO TRANSMITTING SET AN/FRT-53



HEADQUARTERS, DEPARTMENT OF THE ARMY
16 JANUARY 1962

WARNING

Be careful when working on the 500, 225-volt plate and power supply circuits, or on the 115-volt ac line connections.

DON'T TAKE CHANCES! EXTREMELY HIGH VOLTAGES EXIST IN THE FOLLOWING UNITS

Pa tube V203 in rf amplifier chassis	3,000 volts
High voltage power supply	3,000 volts
Antenna terminals	3,000 volts

RADIATION HAZARD

Tubes type OB2 and OA2 are used in this equipment and contain a small amount of radioactive material. These tubes are potentially hazardous when broken. Contact qualified medical personnel immediately in case of accidental cut. For further instructions, refer to TB SIG 225.

Technical Manual }
 No. 11-5820-472-12 }

HEADQUARTERS,
 DEPARTMENT OF THE ARMY
 WASHINGTON 25, D. C., 16 January 1962

RADIO TRANSMITTING SET AN/FRT-53

		Paragraph	Page
CHAPTER	1. INTRODUCTION		
Section	I. General	1, 2	3
	II. Description and data	3-15	3-9
CHAPTER	2. INSTALLATION AND INITIAL ADJUSTMENTS	16-26	13-21
CHAPTER	3. OPERATION		
Section	I. Controls, indicators, and connectors	27-32	22-27
	II. Operating instructions	33-43	28-37
CHAPTER	4. MAINTENANCE INSTRUCTIONS		
Section	I. Operator's maintenance	44-48	39-42
	II. Second echelon maintenance	49-57	42-54
CHAPTER	5. BASIC THEORY	58-61	59
CHAPTER	6. SHIPMENT AND LIMITED STORAGE AND DEMOLITION TO PREVENT ENEMY USE		
Section	I. Shipment and limited storage	62, 63	61
	II. Demolition of materiel to prevent enemy use	64-66	62
APPENDIX	I. REFERENCES		64
	II. MAINTENANCE ALLOCATION		65
INDEX			69

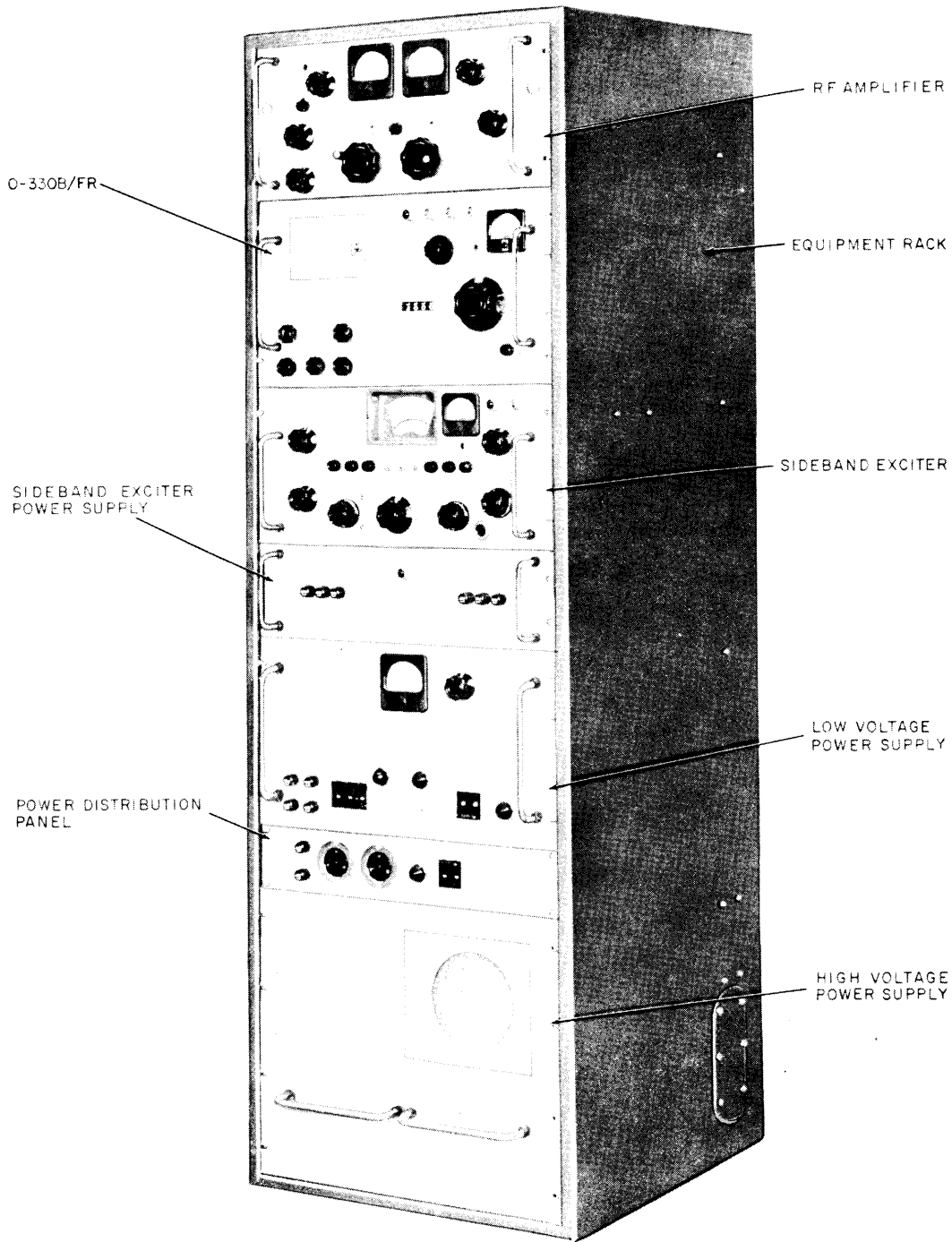

TM5820-472-12-1

Figure 1. Radio Transmitting Set AN/FRT-53 (less manuals and running spares).

CHAPTER 1

INTRODUCTION

Section I. GENERAL

1. Scope

This manual describes Radio Transmitting Set AN/FRT-53 (fig. 1) and covers installation procedures, operation, and first and second echelon maintenance. The manual includes instructions for cleaning and inspecting the equipment, and replacement of parts available to first and second echelon maintenance personnel.

2. Forms and Records

a. Unsatisfactory Equipment Reports. Fill out and forward DA Form 468 (Unsatisfactory Equipment Report) as specified in AR 700-38.

b. Report of Damaged or Improper Shipment. Fill out and forward DD Form 6 (Report of Damaged or Improper Shipment) as specified in AR 700-58.

c. Preventive Maintenance Forms. Prepare DA Form 11-238 (fig. 17, 18 and

19) (Maintenance Check List for Signal Equipment (Sound Equipment, Radio, Direction Finding, Radar, Carrier, Radiosonde, and Television)), in accordance with instructions on the form.

d. Parts List Form. Forward DA Form 2028 (Recommended Changes to DA Technical Manual Parts Lists or Supply Manual 7, 8, or 9) direct to the Commanding Officer, U. S. Army Signal Materiel Support Agency, ATTN: SIGMS-ML, Fort Monmouth, N. J., with comments on parts listings (appendix II).

e. Comments on Manual. Forward all other comments on this publication direct to the Commanding Officer, U. S. Army Signal Support Agency, ATTN: SIGMS-PA2d, Fort Monmouth, N. J.

f. Index of Equipment Publications. Refer to DA Pamphlet 310-4 to determine what Changes to or revisions of this publication are current.

Section II. DESCRIPTION AND DATA

3. Purpose and Use

The AN/FRT-53 is a 1-kilowatt (kw) transmitter that provides multichannel, long-range, continuous transmission of single-sideband (ssb), double-sideband (dsb), or independent-sideband (isb) radio signals in the radiofrequency (rf) range of 2 to 32 megacycles (mc). The AN/FRT-53 is primarily intended for fixed station or mobile operation in a multiplexed communications system. The AN/FRT-53 may also be used to provide continuous-wave (cw) or amplitude modulation (am.) transmission.

4. Common Names

The only component within the AN/FRT-53 configuration that has nomenclatured is

Oscillator, Radio Frequency 0-330B/FR. The remaining items are listed below by the commercial designation and common name.

Commercial designation	Common name
PAL-1K consisting of:	Rf amplifier and power supply assembly:
RFD-1	Rf amplifier
PS-4	Low voltage power supply
PS-5	High voltage power supply
SBE-3 consisting of:	Sideband exciter assembly:
AO-101	Sideband exciter
A-1397	Sideband exciter power supply
APP-4	Power distribution panel
RAK-10	Equipment rack

5. Technical Characteristics

a. Rf Amplifier and Power Supply Assembly.

Frequency range.....	2 to 32 mc continuous, band-switched.
Output power.....	1,000-watt peak envelope power; 1,000 watts, cw or am.
Types of transmission	Ssb, dsb, isb, cw, and low-level am.
Tuning	Front-panel manual controls.
Output impedance:	
Unbalanced	72 ohms.
Balanced	600 ohms.
Signal to distortion ratio	At least 40 db below peak envelope power output.
Harmonic radiation:	
Second harmonic .	At least 40 db below peak envelope power output.
All other harmonics	At least 50 db below peak envelope power output.
Input requirements ..	100 mw produces full output.
Primary power requirements.....	115- or 230-volt, single-phase, 50/60 cycle ac; approximately 1,900 watts.
Number of tubes:	
Rf amplifier	3.
Low voltage power supply	8.
High voltage power supply...	2.

b. Oscillator, Radio Frequency O-330B/FR.

Number of tubes.....	14.
Primary power requirements	250 watts from a 115- or 230-volt, 50/60-cycle, single-phase input.

(1) High frequency oscillator section.

Frequency range.....	2 to 64 mc (either crystal controlled or continuously variable).
Output impedance....	75 ohms.
Output level.....	2 watts throughout range of 2 to 4 mc, and 0.5 watt throughout range of 4 to 64 mc.
Crystal frequencies..	2 to 4 mc.
Output voltage waveform	Sinusoidal with no spurious frequencies.
Stability	Less than 20-cps per mc change in 0° to 50° C temperature range.
Calibration	Direct-reading calibration in cps between 2 and 4 mc. Checked against 100-kc oscillator at 50-kc checkpoints.
Dial accuracy.....	20 cps per mc.
Line voltage change effects	Maximum change of 10 cps per mc for 10-percent change in line voltage.

(2) Intermediate frequency oscillator section.	
Frequency range	3.2 to 3.9 mc (crystal-controlled oscillator).
Output level.....	2 volts across 75 ohms.

(3) Beat frequency oscillator section of variable frequency oscillator.

Frequency range.....	300 to 1,000 kc (crystal-controlled oscillator).
Output level.....	6 volts across 1,000 ohms.

c. Sideband Exciter Assembly.

Frequency range.....	2 to 32 mc continuous, band-switched.
Types of transmission	Ssb, dsb, isb, cw, and low-level am.
Frequency control ...	Crystals housed in temperature-controlled ovens.
Stability	1 cycle per megacycle in 24 hours.
Tuning controls.....	Calibrated directly in frequency.
Output power.....	Continuously adjustable from zero to 1 watt.
Output impedance....	72 ohms.
Carrier suppression .	At least 55 db below peak envelope power level.
Carrier insertion....	Continuously adjustable.
Spurious output.....	At least 60 db below peak envelope power output.
Harmonic Suppression:	
Second harmonic .	At least 40 db below peak envelope power output.
All others	At least 50 db below peak envelope power output.
Rejection of unused sideband	500-cps tone 60 db below transmitted peak envelope power.
Audio input:	
Line	Two independent 600-ohm channels, balanced or unbalanced, -20-db level required for full rf output (reference: 0 db = 1 mw at 1,000 cps).
Local microphone	500,000-ohm input. -50-db level required for full rf output.
Audio response per sideband	Within 3 db from 350 to 7,500 cps.
Voice control operation	Voice control with adjustable gain and squelch control.
Primary power requirements.....	115- or 230-volt, single-phase, 50/60-cycle ac; 140 watts at intervals when oven cycles.
Number of tubes:	
Sideband exciter..	20.
Sideband exciter power supply...	2.
d. Power Distribution Panel.	
Protective device....	MAIN POWER circuit breaker (for all components of AN/FRT-53); trips at 20 amperes \pm 2.

6. Components of Radio Transmitting Set AN/FRT-53

a. Components (fig. 1 and 3).

Quantity	Item	Height (in.)	Depth (in.)	Width (in.)	Unit weight (lb)
1	Rf amplifier and power supply assembly consisting of:				
	Rf amplifier	8-3/4	17-1/8	19	40
	Low voltage power supply	10-1/2	12	19	60
	High voltage power supply	15-3/4	16-1/4	19	260
1	Oscillator, Radio Frequency O-330B/FR	10-1/2	16	19	75
	Sideband exciter assembly consisting of:				
	Sideband exciter	8-3/4	15	19	35
	Sideband exciter power supply	5-1/4	10	19	36
1	Power distribution panel	4	10	19	40
1	Equipment rack	66-3/4	20	21-1/2	450
1 set	Running spares (b below)				

b. Running Spares (fig. 2).

(1) Tubes.

Tube type	Quantity		Item No. (fig. 2)	Used in	Reference designation
	In use	Running spares			
OA2	6	3	7	Sideband exciter Sideband exciter power supply Low voltage power supply O-330B/FR	V106, V121 V402 V705, V707 V102
OB2	2	1	7	Low voltage power supply	V706, V708
5R4GY	2	1	6	Sideband exciter power supply Low voltage power supply	V401 V702
5V4G	1	1	5	O-330B/FR	V101
6AB4	5	2	14	Sideband exciter O-330B/FR	V101, V124, V125, V127 V301
6AH6	3	2	14	Sideband exciter	V114, V118, V125
6AU6	1	1	14	Low voltage power supply	V704
6X4	1	1	12	Low voltage power supply	V701
6336A	1	1	1	Low voltage power supply	V703
6AQ5	6	3	12	O-330B/FR	V105, V203, V204, V205, V206, V207
6AL5	1	1	22	Sideband exciter	V111
6BE6	1	1	14	O-330B/FR	V103
6C4	1	1	14	O-330B/FR	V202
6CL6	2	1	17	Sideband exciter	V116, V119
6U8A	2	1	21	Sideband exciter	V110, V117
12AT7	3	2	21	Sideband exciter	V113, V122, V123
12AU7	6	3	21	Sideband exciter O-330B/FR	V105, V112, V115 V104, V201, V302
TV-100	1	1	3	Rf amplifier	V203
872A	2	1	4	High voltage power supply	V401, V402
5763	1	1	17	Rf amplifier	V201
6146	2	1	2	Sideband exciter Rf amplifier	V120 V202

(2) Diodes.

Diode type	Quantity		Item No. (fig. 2)	Used in	Reference designation
	In use	Running spares			
1N67	4	2	9	Sideband exciter Rf amplifier	CR107, CR108 CR201, CR202
1N303	7	3	10	Sideband exciter Rf amplifier	CR111, CR112, CR113, CR114 CR203, CR204, CR205
DD-100	2	1	8	Sideband exciter	CR115, CR116
1N34	4	2	9	O-330B/FR	CR101, CR102, CR201, CR202
YR-100-200R5	1	1	11	Low voltage power supply	CR701

(3) Lamps.

Lamp type	Quantity		Item N. (fig. 2)	Used in	Reference designation
	In use	Running spares			
NE51	5	2	16	Sideband exciter	I101, I102
44	1	1	16	O-330B/FR	I301, I303, I304
44(AF)	1	1	16	O-330B/FR	I302
3S6	4	2	20	Sideband exciter power supply	I401
				Low voltage power supply	I701, I702, I703
				Power distribution panel	I501

(4) Fuses.

Fuse type	Quantity		Item No. (fig. 2)	Used in	Reference designation
	In use	Running spares			
AGC-1/4	1	6	18	Low voltage power supply	F704
AGC-2	2	12	18	Low voltage power supply	F703
				O-330B/FR	F102
AGC-3	1	6	18	O-330B/FR	F101
AGC-5	1	6	18	Low voltage power supply	F701
MDL-1/10	1	6	20	Low voltage power supply	F702
MDL-1/4	1	12	20	Sideband exciter power supply	F403
MDL-2	1	12	20	Sideband exciter power supply	F401
MDL-3	1	12	20	Sideband exciter power supply	F402
AGC-15	2	12	19	Power distribution panel	F501, F502

7. Radio Transmitting Set AN/FRT-53

(fig. 1 and 3)

a. Radio Transmitting Set AN/FRT-53 includes an rf amplifier, a variable master oscillator (vmo), a sideband exciter, and three power supplies. All these components are contained in an equipment rack. Only the front of the equipment rack is open to allow for mounting, maintenance, and operation of the various components. Two fans are mounted on the rear wall of the equipment rack to provide air circulation. Air filters are adjacent to the fans and at the top of the equipment rack. Also attached to the rear wall of the equipment rack are two spring-loaded counterweights. These counterweights are connected to the rear cabling of the various components to prevent snagging of the cabling when these components are pushed into the equipment rack.

b. All components, except the sideband exciter power supply, the power distribution panel, and the high voltage power supply, are equipped with drawer slides which permit the components to be pulled out to reach the various parts. The sideband ex-

citer power supply and the power distribution panel are held in place in the equipment rack by four screws each. The high voltage power supply, the heaviest component, is located at the bottom of the equipment rack for greater weight support.

c. The primary power connection for the AN/FRT-53 is made at the power distribution panel which, in turn, distributes the power to the remaining components including an ac power strip. Power for the O-330B/FR, the sideband exciter assembly, and the fans, B602 and B603, is obtained by connection of the line cords for these units into the ac receptacles (jacks J612, J613, and J614 (fig. 3), respectively) on the ac power strip. Rf connections to the antenna system are made from the rear of the rf amplifier.

8. Rf Amplifier

(fig. 1)

The rf amplifier chassis is slide mounted on tracks within the equipment rack. High voltage for the rf amplifier is supplied by the high voltage power supply; all other alternating-current (ac) and direct-current

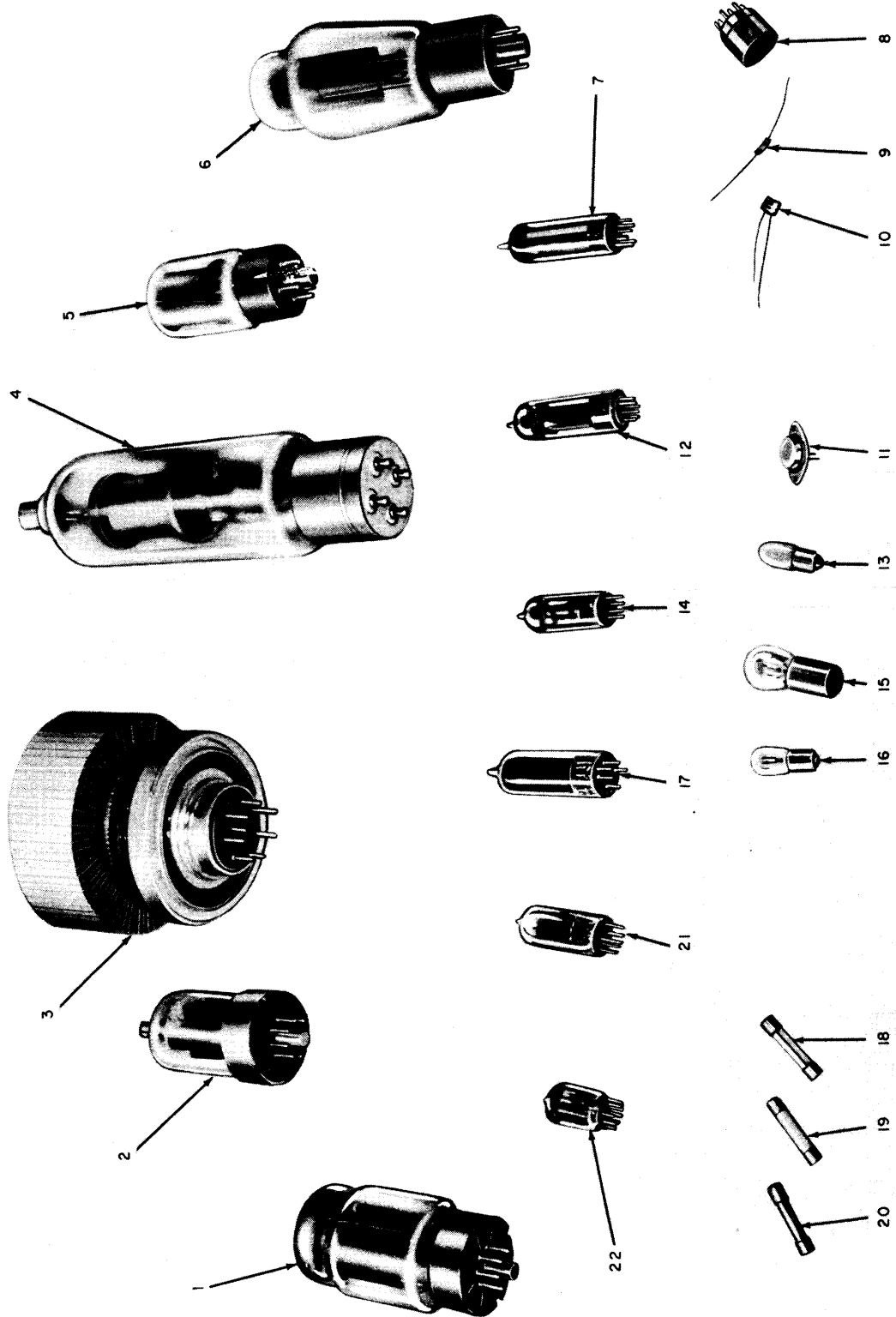

TM5820-472-12-33

Figure 2. Running spares.

(dc) operating voltages are supplied by the low voltage power supply. Two front-panel meters monitor circuit conditions within the rf amplifier. Rf and power connections are made at the rear of the rf amplifier. An ALDC switch on the rear panel selects application of a gain control voltage to rf stages within the rf amplifier chassis or to the sideband exciter. Cover interlocks remove the high voltage when the top or bottom covers is removed.

9. Oscillator, Radio Frequency O-330B/FR (fig. 1)

The O-330B/FR is slide mounted on the equipment rack just below the rf amplifier chassis. Operating controls are on the front panel and a subpanel accessible through a door on the upper left side of the front panel. Fuses, signal and power connectors, and a crystal-selector switch are at the rear of the chassis. The O-330B/FR provides an rf signal in the 2- to 4-mc range to the sideband exciter. This frequency may be read directly on the MASTER OSCILLATOR FREQUENCY dial.

10. Sideband Exciter Assembly (fig. 1)

The sideband exciter assembly consists of the sideband exciter and the sideband exciter power supply. The sideband exciter is slide mounted and the power supply is panel mounted with four screws.

a. *Sideband Exciter.* All operating controls and indicators are mounted on the front panel of the sideband exciter. Controls used by higher echelon personnel are on the top, bottom, and rear of the chassis. Two crystal ovens are contained in the sideband exciter. One crystal oven, on the left side of the chassis, contains 8 high frequency crystal (accessible from the bottom of the chassis) and 10 medium frequency crystal sockets (accessible from the top of the chassis). The medium frequency crystals are not supplied with the AN/FRT-53. The second crystal oven, on top of the chassis, houses the 250-kilo-cycle (kc) crystal. Input and output signal connections are made through a ter-

minal board and six coaxial connectors at the rear of the chassis. Operating potentials, provided by the sideband exciter power supply (*b* below), are applied to the sideband exciter through an interconnecting cable and a multipin connector on the rear of the chassis. A front-panel MIKE receptacle is used with an external microphone.

b. *Sideband Exciter Power Supply.* The sideband exciter power supply front panel houses six fuses and one indicator lamp. The three fuses on the left are spares. Two receptacles are also mounted on the chassis. One is the primary power connection, and the second applies operating potentials to the sideband exciter through an interconnecting cable.

11. Low Voltage Power Supply (fig. 1)

a. The low voltage power supply is slide mounted below the sideband exciter power supply. All operating controls, indicators, and fuses are on its front panel. Three adjustment controls are on a small shelf mounted behind the upper-left portion of the front panel. These controls are made accessible when the low voltage power supply chassis is pulled out on its drawer slides.

b. All connections consist of a coaxial jack, a three-pronged jack, two multipin jacks, and a terminal board. The three-pronged jack and the terminal board are used for connections to the power distribution panel. One of the multipin jacks connects the ac power to the high voltage power supply; the other multipin jack connects the required operating voltages to the rf amplifier chassis. This jack also couples the automatic load and drive control (aldc) signal from the rf amplifier back to the low voltage power supply where it is routed through the coaxial jack to the sideband exciter.

12. Power Distribution Panel (fig. 1)

The power distribution panel, which is panel mounted with four screws, routes primary power from the external power

source to the various units of the AN/FRT-53. The MAIN POWER circuit breaker, a power indicator lamp two utility outlets, and two fuses are mounted on the front panel. Metal links on a board permit strapping of the power distribution panel for either 115- or 230-volt ac operation. All external connections to the sideband exciter and the low voltage power supply are made through two terminal boards and a multipin jack on the rear of the unit.

13. High Voltage Power Supply (fig. 1)

The high voltage power supply is located at the bottom of the equipment rack. Primary power for the high voltage power supply is supplied from the low voltage power supply. An output of 3,000 volts dc is cabled to the rf amplifier chassis. All connections to the high voltage power supply are made through two connectors located in a compartment in the chassis. A small door on the front panel, which is held closed by a 1/4-turn fastener, provides access to the blower assembly. Two interlocks behind this door remove the high voltage and turn off the blower when the door is opened. An interlock at the top-right side of the chassis removes the high voltage when the top cover is removed.

14. Additional Equipment Required

The following equipment is not supplied as part of the AN/FRT-53, but is needed for operation:

a. Antenna and Transmission Line. A 52-ohm antenna and transmission line is required to radiate the rf signal generated by the AN/FRT-53.

b. Dummy Load. A 52-ohm, 1,000 watt dummy load (such as, RF Wattmeter AN/URM-120) is required to terminate the AN/FRT-53 in its proper impedance and to dissipate the rf energy generated when it is being tuned.

c. Microphone. A high-impedance (500,000-ohm) microphone must be used to modulate the AN/FRT-53. The microphone is connected to the MIKE jack on the sideband exciter.

d. Telegraph Key. A telegraph key must

be used to key AN/FRT-53 for cw transmission.

e. Power Cable. A power cable is required to connect the AN/FRT-53 to a 115-volt ac, 1,900-watt power source.

15. System Application (fig. 4)

The AN/FRT-53 may be used as a radio link in a multiplexed teletypewriter and telephone long-distance communications system. The radio link provides facilities for two 6-kc channels. With suitable multiplex equipment, four independent 3-kc channels are available. The lower sideband output of the AN/FRT-53 can accept two 3-kc channels, and the upper sideband can accept two additional 3-kc channels. Figure 4 illustrates a typical communications system using the AN/FRT-53 as a radio link.

a. Teletypewriter Signal Input. Dc signals from two teletypewriters or distributor units are applied to a frequency shift tone keyer. The two-channel output of the tone keyer is applied to multiplexer No. 1. The output frequencies of the multiplexer are applied to the sideband generator section of the AN/FRT-53.

b. Telephone Input. Voice signals from two telephone sets are applied to multiplexer No. 2. The frequency-multiplexed output from multiplexer No. 2 is also applied to the sideband generator section of the AN/FRT-53.

c. AN/FRT-53. The multiplexed voice and teletypewriter signals are converted by the AN/FRT-53 into sideband energy. The output level is raised to 1 kw and applied to a transmitting antenna for transmission to a distant receiver.

d. Receiving System. The rf signals received at the receiving station are applied through a receiver to a converter. The converter separates the upper and lower sidebands and applies the energy within these sidebands to demultiplexers No. 1 and No. 2. The teletypewriter intelligence is separated into two channels by the demultiplexer and routed to teletypewriter equipment through a frequency shift tone converter. The voice energy is separated

into two voice channels by demultiplexer No. 2 and applied to telephone equipment.

e. *Microphone Input.* This facility permits voice input signals to be applied directly to the AN/FRT-53. When the micro-

phone is used, its output modulates either the *entire* upper or lower sideband and thereby limits intelligence from external signal generating equipment to one sideband only.

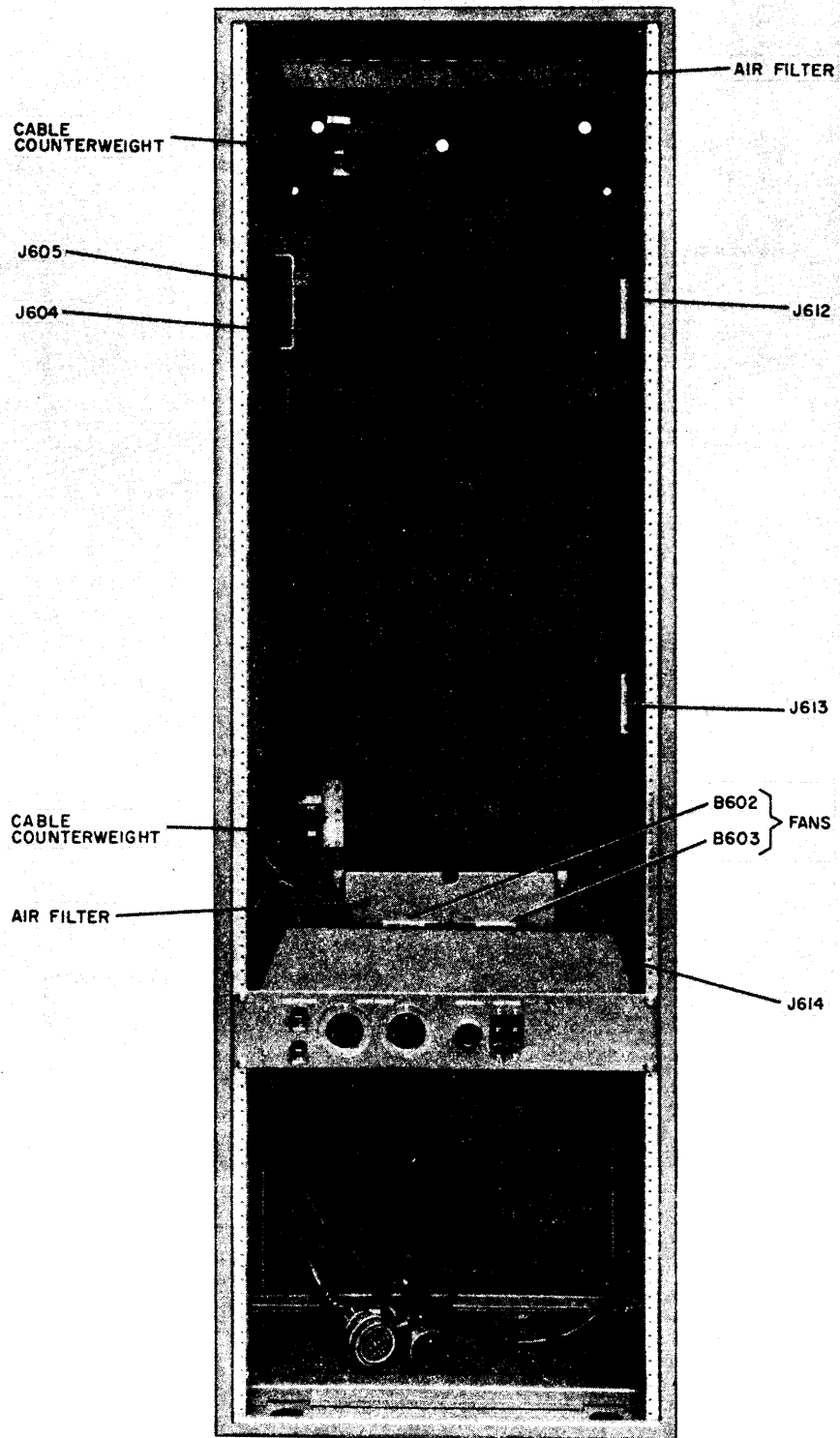

TM5820-472-12-32

Figure 3. Equipment rack.

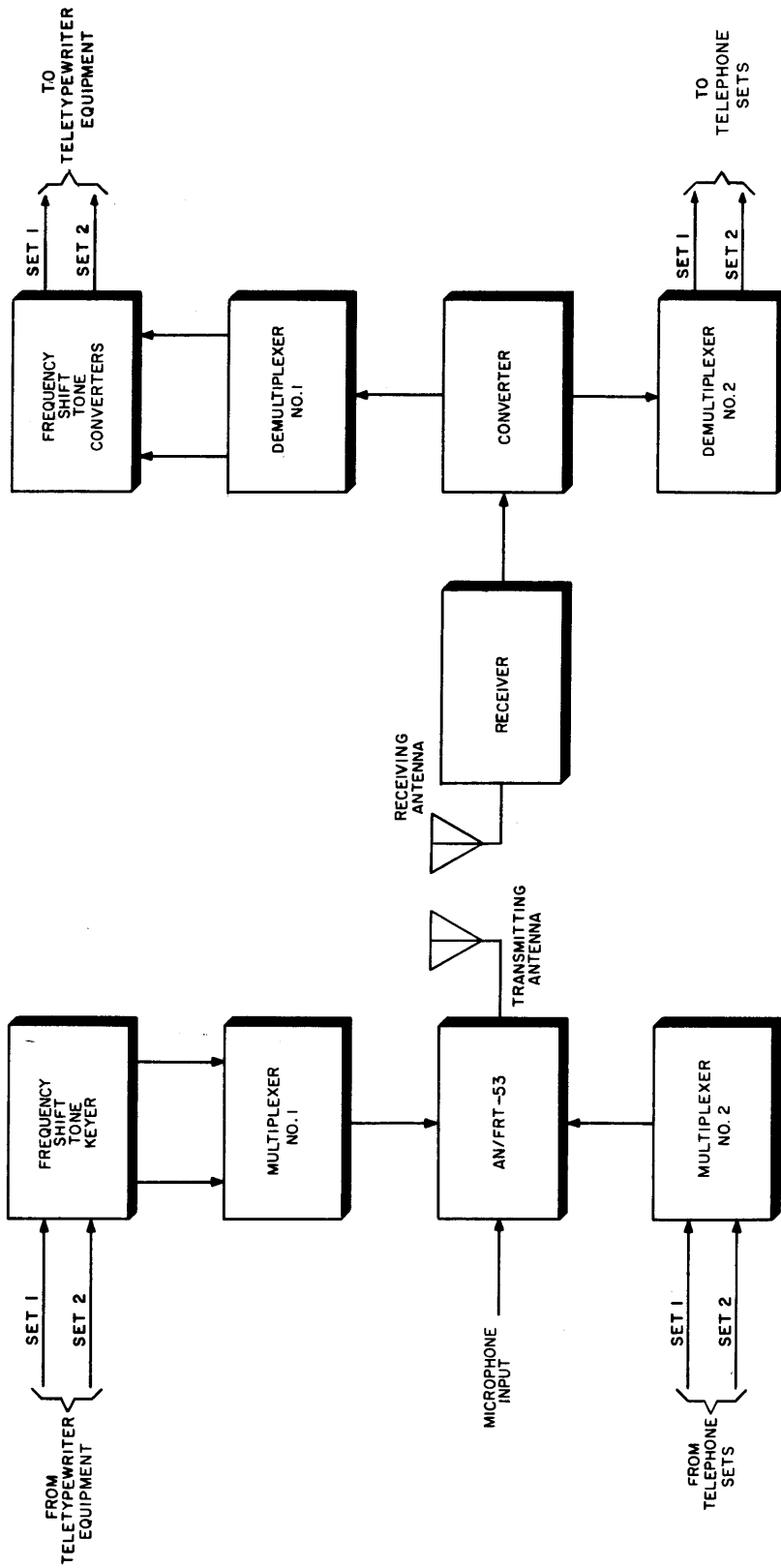

TM5620-472-12-28

Figure 4. Radio Transmitting Set AN/FRT-53, system application.

CHAPTER 2

INSTALLATION AND INITIAL ADJUSTMENTS

16. Siting

The distance range that can be obtained with the AN/FRT-53 largely depends on the selection of a suitable location for the antenna. Ground conductivity and height of surrounding terrain and obstructions should be carefully weighed before the final decision is made. Where possible, the station's transmitting and receiving functions should be situated at widely separated locations to eliminate any possibility of interference. The selection of a site and design of the installation should be undertaken only by trained personnel.

17. Housing Requirements

The building (or van) that houses the AN/FRT-53 must meet the following requirements:

a. The floor must be capable of sustaining the weight of the equipment in a level position without vibration. Total weight of the equipment, including the rack and associated cables, is approximately 1,200 pounds.

b. The floorspace must measure at least 15 by 8 feet to provide room for efficient and convenient use of the equipment. This area includes space for the actual equipment and enough space to allow for removal of units for servicing and for work by maintenance personnel around the equipment.

c. A ceiling height of at least 7 feet is necessary to allow for installation of rf transmission lines.

d. Adequate ventilation must be provided. Operation of the AN/FRT-53 in a poorly ventilated room will cause the surrounding temperature to become too high. Temperature and humidity control and filtering should be used when dust, humidity, or temperature is extreme.

18. Checking Unpacked Equipment

a. Inspect the equipment for possible damage incurred during shipment. If the

equipment is damaged, refer to paragraph 2.

b. See that the equipment is complete as listed on the packing slip. If a packing slip is not available, check it against the table of components (para 6).

c. If the equipment has been used or re-conditioned, see if it has been changed by a modification work order (MWO). Current MWO's applicable to the equipment are listed in DA Pam 310-4. If modified, the MWO number will appear on the front panel near the nomenclature plate.

19. Uncrating and Unpacking

a. *General.* The AN/FRT-53 may be shipped in oversea packing crates or in domestic packing cases. When a new AN/FRT-53 is received, move it to its intended site *before* uncrating or unpacking.

b. *Uncrating and Unpacking Procedure.* The entire AN/FRT-53, including spare parts, is packed in wooden crates. The large units are individually crated. When unpacking the equipment, proceed as follows:

- (1) Place the wooden crate near the position where the equipment is to be installed.
- (2) Cut and remove the steel straps.
- (3) Remove the nails with a nailpuller.
- (4) Remove the top and sides of the crate.

Caution: Prying off the sides or top of the crate may result in damage to the equipment.

- (5) Remove and open the waterproof carton. Remove the inner carton which is packed in a moisture-vaporproof barrier bag.
- (6) Open the bag and the inner carton, and remove the corrugated filler protective inserts.
- (7) Carefully remove each unit, spare parts, technical manuals, and all accessories.

20. Equipment Rack Installation Procedure (fig. 3 and 29)

All components, except the power distribution panel, are shipped in individual containers. The power distribution panel is normally shipped in place in the equipment rack. Before installing the remaining components in the equipment rack, check to see that cable CA-588-1 is connected between the ac output terminals on the power distribution panel and the ac power strip (fig. 29). Also, check to see that plug P623 is connected to jack J614 to provide power for the two fans. To install the remaining components, proceed as follows (Refer to paragraph 22 for installation details of rack-mounted and panel-mounted components):

a. Choose a location for the equipment that meets the space requirements listed in paragraph 17.

b. The equipment rack has predrilled holes for permanent mounting. The holes are at the base of the rack and along the top of the rear wall. Use these holes as templates for drilling holes in the floor (or mounting surface) and the wall of the shelter or van.

Note: When the equipment is to be shock-mounted, a shock-mounting kit and separate installation instructions are supplied.

c. Use bolts to secure the equipment rack to the floor and the wall.

d. Pass the input power cable through a hole in the base of the equipment rack, and connect the power cable leads to the ac input terminals of the power distribution panel.

e. Place the high voltage power supply in position so that the rear edges of the sliders on the bottom of the component are resting on the front edge of the equipment rack base.

f. Connect the plug at the end of cable AC-490(605) to jack J401 on the high voltage power supply.

g. Extend the tracks of the drawer slides just above the power distribution panel, and slide the low voltage power supply onto the tracks until the release buttons catch. Press the release buttons and push the component into the equipment rack until

the release buttons engage the holes in the tracks.

h. Connect plug P401 on the cable extending from the high voltage power supply to jack J702 on the low voltage power supply.

i. Push the high voltage power supply into the equipment rack and secure it with eight screws.

j. Connect the plug on cable W611 (which extends from the ac output terminals of the power distribution panel) to jack J703 on the low voltage power supply.

k. Connect the numbered fan-stripped leads of cable W622 (extending from the power distribution panel) to the terminals of E701 on the low voltage power supply.

l. Connect the plug on cable W606 to jack J701 on the low voltage power supply.

m. Push the low voltage power supply into the equipment rack and secure it with eight screws.

n. Place the sideband exciter power supply into the equipment rack above the low voltage power supply and secure it with four screws.

o. Extend the tracks of the drawer slides just above the sideband exciter power supply and position the sideband exciter in the equipment rack; follow the same procedure as for the low voltage power supply (g above).

p. Connect plug P101 on cable W101 to jack J402 on the sideband exciter power supply and plug P102 on cable W101 to jack J109 on the sideband exciter.

q. Connect plug P401 on cable W401 to jack J401 on the sideband exciter power supply and plug P402 on cable W401 to jack J613 on the ac power strip.

r. Connect the numbered fan-stripped leads on cable W609 (coming from jack J501 on the power distribution panel) to the terminals of E101 on the sideband exciter.

s. Connect the aldc cable between jack J704 on the low voltage power supply and jack J113 on the sideband exciter.

t. Extend the tracks of the drawer slides just above the sideband exciter and position the 0-330B/FR in the equipment rack; follow the same procedure as for low voltage power supply (g above).

u. Connect plug P604 on cable W608 to jack J208 on the O-330B/FR and plug P613 on cable W608 to jack J104 on the sideband exciter.

v. Connect plug P203 on cable W202 (which extends from the O-330B/FR) to jack J612 on the ac power strip.

w. Extend the tracks of the drawer slides just above the O-330B/FR and position the rf amplifier in the equipment rack; follow the same procedures as for the low voltage power supply (g above).

x. Connect plug P612 on cable W607 to jack J201 on the rf amplifier and plug P611 on cable W607 to jack J103 on the sideband exciter.

y. Push the sideband exciter into the equipment rack and secure it with four screws.

z. Push the O-330B/FR into the equipment rack and secure it with eight screws.

aa. Connect plug P505 at the end of the cable (with the large connector) extending from the rf amplifier to jack J605.

ab. Connect plug P504 at the end of the cable (with the small connector) extending from the rf amplifier to jack J604.

ac. Connect the associated antenna cable to jack J202 (or E203 if required) on the rf amplifier.

ad. Push the rf amplifier into the equipment rack and secure it with four screws.

21. Rewiring for Conversion From 115- to 230-Volt Ac Source

The equipment may be operated from 115- or a 230-volt ac source. This procedure assumes that the equipment will be delivered wired for 115-volt operation and must be rewired for a 230-volt ac source. (If the equipment is delivered wired for 230-volt operation and must be operated from a 115-volt ac source, adapt these instructions accordingly.) To convert this equipment from 115-volt operation to 230-volt operation, perform the following wiring, fuse and circuit breaker changes:

a. *Equipment Rack*. Refer to figure 29 and change the wiring on E608 as indicated.

b. *O-330B/FR*.

(1) *E301 and E302*. Refer to figure 5 for wiring changes.

(2) *Transformer T101*. Refer to figure 6 for wiring changes.

(3) *OVENS fuse*. Change from 3 amperes to 1.5 amperes.

(4) *POWER fuse*. Change from 2 amperes to 1 ampere.

c. *Sideband Exciter*. Change connections on TB101 as shown in figure 7.

d. *Sideband Exciter Power Supply*.

(1) *Transformers T401 and T402*. Refer to figure 7 for wiring changes.

(2) *MAIN fuse*. Change from 3 amperes to 1.5 amperes.

(3) *OVENS fuse*. Change from 2 amperes to 1 ampere.

e. *Low Voltage Power Supply*.

(1) *Transformer T701*. Remove connection from 115-volt tap and connect to 230-volt tap (fig. 7).

(2) *Circuit breaker CB701*. Refer to figure 7 for wiring changes.

f. *Power Distribution Panel*.

(1) *Ac output terminals*. Refer to figure 7 and place the metal links as indicated.

(2) *UTILITY POWER fuses*. This equipment is delivered with two 230-volt, 15-ampere fuses installed. When operation from a 115-volt ac source is required, these two fuses may be changed to 30-ampere fuses.

g. *High Voltage Power Supply*. Refer to figure 7 and change wiring on primary of T401.

22. Component Installation

Complete the wiring modifications for 115-volt or 230-volt operation (para 21) before performing this procedure. All the components are slide mounted, except the sideband exciter power supply and power distribution panel, which are panel mounted. Refer to figures 1 and 3 for component location within the equipment rack.

a. *Installation of Slide-Mounted Components* (fig. 8).

Warning: Two men should install the heavy components such as the O-330B/FR and the power supplies.

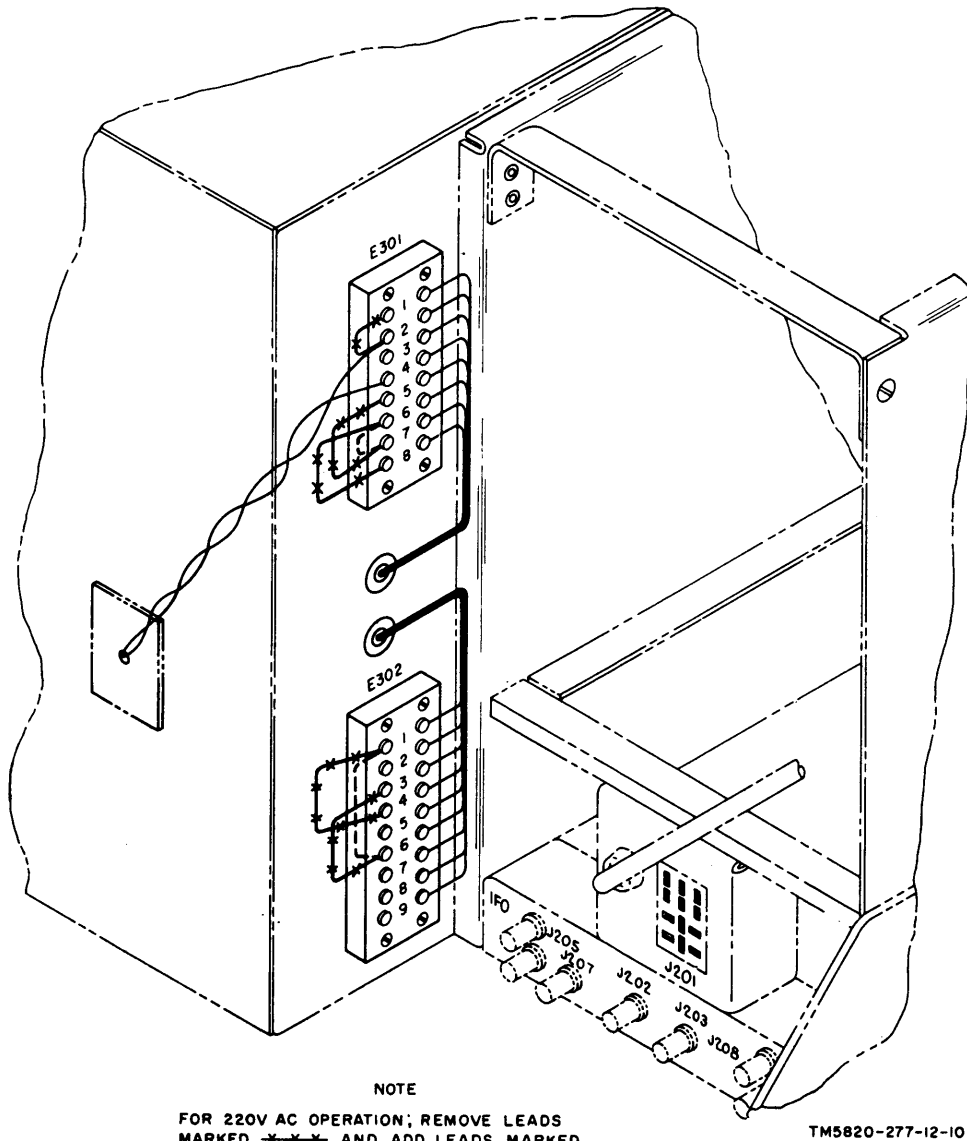

Figure 5. O-330B/FR oven terminal boards, input voltage wiring.

- (1) Set the component in position on the tracks.

Note: It may be necessary to hold the tracks in the extended position while positioning the component.

- (2) Slide the component on the tracks until the release buttons catch.
- (3) Press the release buttons and push the component into the equipment rack until the release buttons engage the holes in the equipment.
- (4) Refer to figures 3 and 29 and make the necessary cable connections.
- (5) When *all* components have been in-

stalled and cabled, press the release buttons and push the component into the equipment rack. To prevent the cables extending from the rf amplifier and the low voltage power supply from snagging, pass these cables through the cable counterweights (fig. 3).

- (6) Secure the front panel to the equipment rack with screws.

b. Installation of Panel-Mounted Components.

- (1) Set the component in position within the equipment rack.

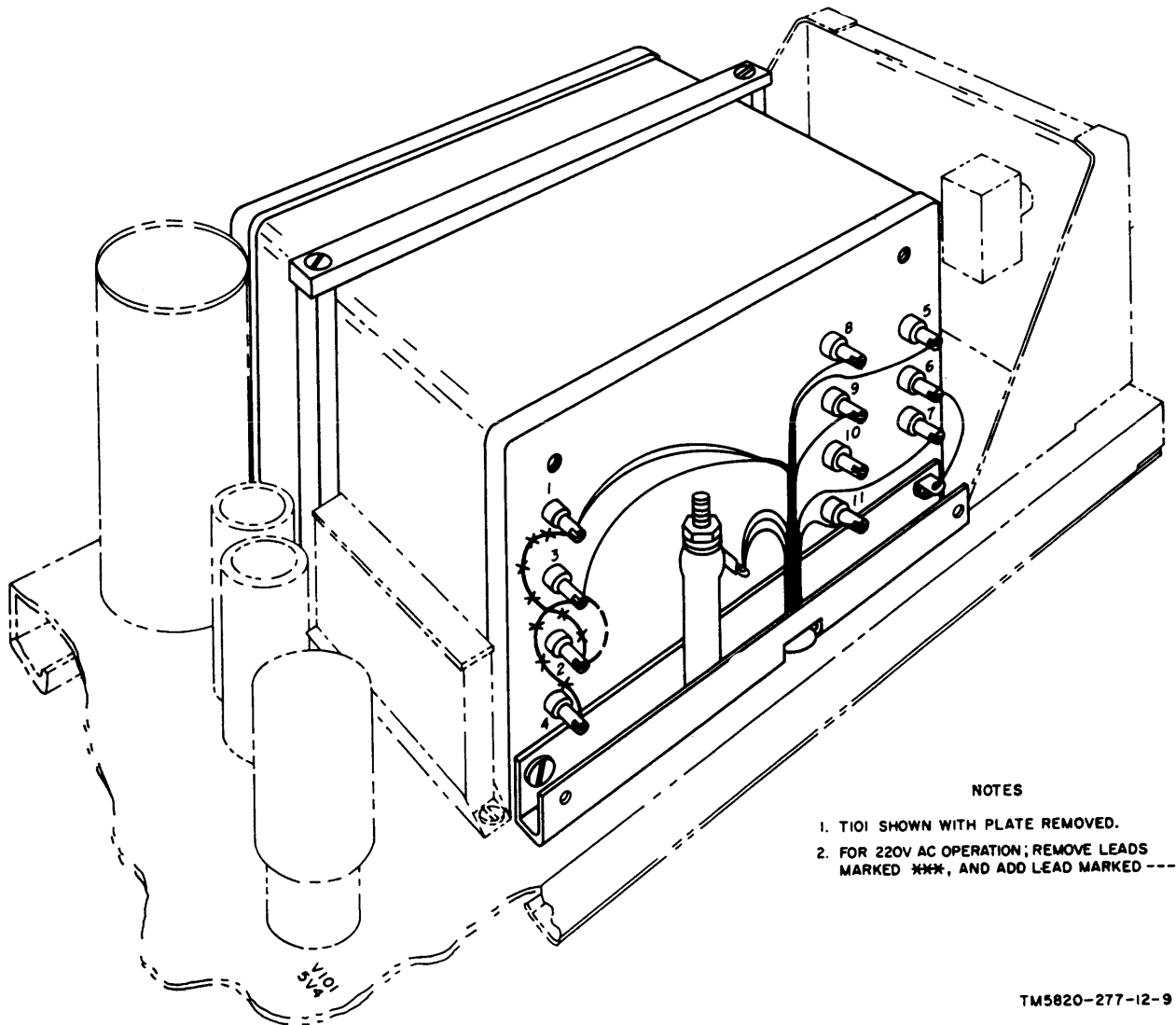

- NOTES
1. T101 SHOWN WITH PLATE REMOVED.
 2. FOR 220V AC OPERATION; REMOVE LEADS MARKED ***, AND ADD LEAD MARKED ---

TM5820-277-12-9

Figure 6. O-330B/FR power supply transformer T101, input voltage wiring modification.

- (2) Refer to figures 3 and 29 and make the necessary cable connections.
- (3) When *all* components have been installed and cabled, push the component into the equipment rack; make sure the cables do not kink or bind.
- (4) Secure the front panel to the equipment rack with screws.

23. External Equipment Connections (fig. 29)

Except for the microphone, which is connected to the MIKE receptacle on the sideband exciter front panel, and the antenna connection to J202 on the rf amplifier, all external equipment is connected to E501 and E502 on the rear panel

of the power distribution panel. Make the following connections for the inputs or facilities given:

Note: Terminals 23 through 32 of E502 are not used when power distribution panel is used as part of the AN/FRT-53 configuration.

a. Channel 1 Input.

- (1) *Balanced line input.* Ground terminal 14 of E501 and apply balanced signal input to terminals 13 and 15.
- (2) *Unbalanced line input.* Ground terminal 15 of E501 and apply unbalanced signal between terminal 13 and ground.

b. Channel 2 Input.

- (1) *Balanced line input.* Ground terminal 19 of E502 and apply balanced

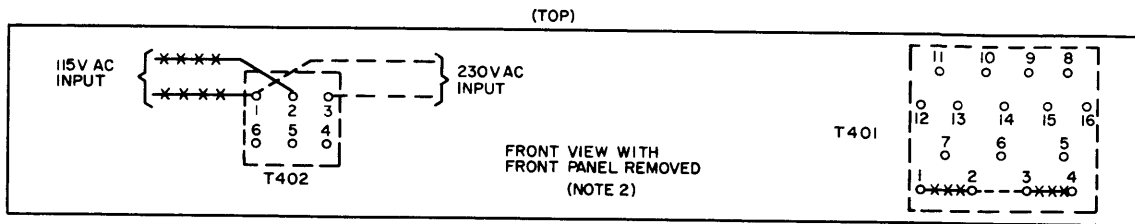

SIDE BAND EXCITER POWER SUPPLY

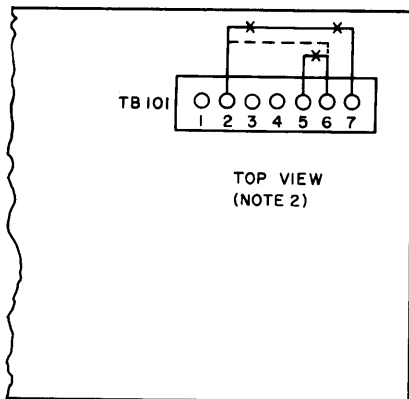

(REAR)
SIDE BAND EXCITER

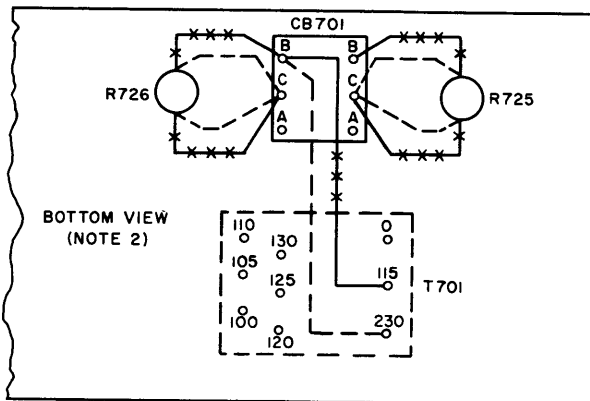

(REAR)
LOW VOLTAGE POWER SUPPLY

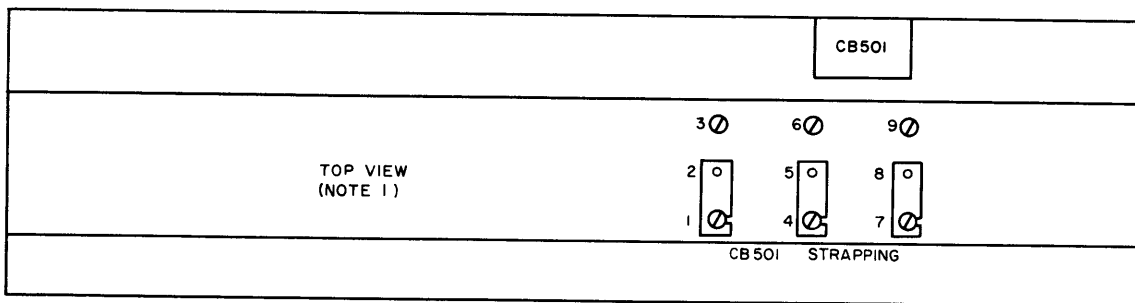

(REAR)
POWER DISTRIBUTION PANEL

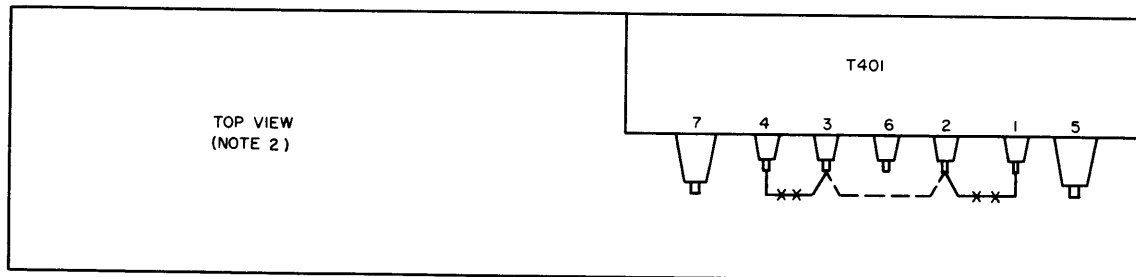

(REAR)
HIGH VOLTAGE POWER SUPPLY

NOTES:

1. FOR 115V AC OPERATION, CONNECT TERMINALS 1 AND 2, 4 AND 5, 7 AND 8.
2. FOR 230V AC OPERATION, CONNECT TERMINALS 2 AND 3, 5 AND 6, 8 AND 9.
2. FOR 115V AC OPERATION, CONNECT LEADS MARKED - - - - -.
- FOR 230V AC OPERATION, CONNECT LEADS MARKED - - - - -.

TM5820-472-12-30

Figure 7. AN/FRT-53, input voltage wiring modifications.

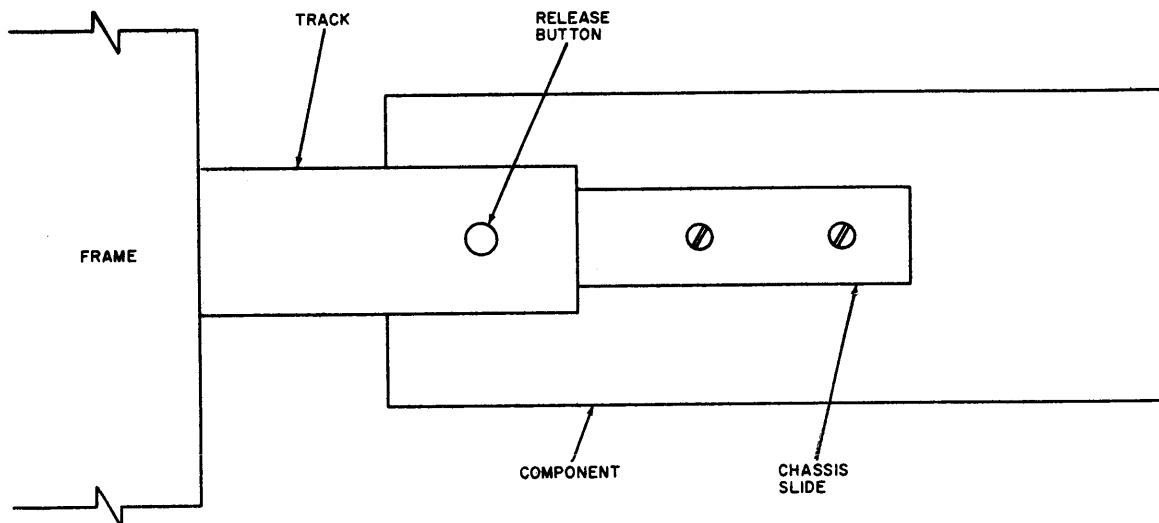

A. NON-TILTING SLIDE MECHANISM

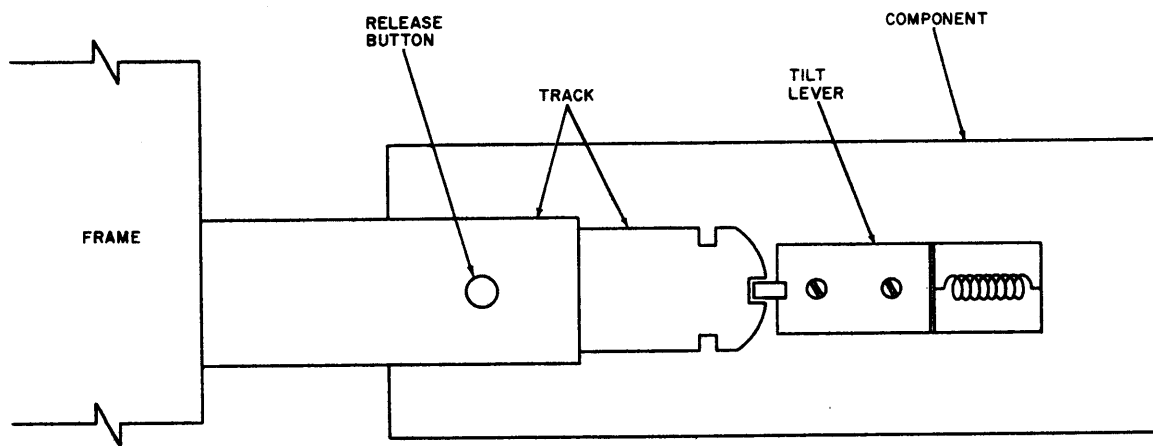

B. TILTING SLIDE MECHANISM

TM5820-472-12-27

Figure 8. Slide-mounting details.

signal input to terminals 18 and 20.

- (2) *Unbalanced line input.* Ground terminal 20 of E502 and apply the unbalanced signal between terminal 18 and ground.

c. Remote Operation. Connect the leads from an on-off switch (or relay terminals) between terminals 2 and 1 of E501. (In remote operation, the TRANSMITTER

VOLTAGES switch on the low voltage power supply is left in STAND BY and the transmitter is turned on when terminal 2 of E501 is grounded by the action of a remote switch.)

d. External Key Line. Remove the jumper between terminals 21 and 22 of E502 and connect a telegraph key between these terminals:

Note: This function is used for cw operation only.

e. *Push-to-Talk Connection.* To energize the push-to-talk circuit externally connect an on-off (or microphone) switch between terminals 9 and 10 (ground) of E501.

f. *Squelch Input.* Connect the audio output of an associated receiver to terminals 11 and 12 of E501 when control of the squelch circuit from a remote receiver is desired.

g. *External Interlocks.* Terminals 5 through 8 of E501 are series connected

with the transmitter interlock circuit. To connect external equipment in series with this interlock circuit, remove the jumper from terminals 5 and 6 (or from 7 and 8) and connect the external interlock circuit in series with these terminals.

24. Checking Cable Connections

(fig. 29)

Before operating the equipment, check to see that the connections listed below have been made.

Cable No.	Connects	
	From	To
W101 W202	Sideband exciter J109 O-330B/FR, P203	Sideband exciter power supply J402 Ac power strip in equipment rack, J612
W401	Sideband exciter power supply J401	Ac power strip in equipment rack, J613
AC-490(605)	Rf amplifier, P202	High voltage power supply, J401
W606	Rf amplifier, P201	Low voltage power supply, J701
W607	Rf amplifier, J201	Sideband exciter, J103
W608	O-330B/FR, J208	Sideband exciter, J104
W609	Power distribution panel, J501	Sideband exciter, E101
W611	Power distribution panel, ac output terminals	Low voltage power supply, J703
W621	Ac junction box in equipment rack, E608	Ac power strip in equipment rack, J614
W622	Power distribution panel	Low voltage power supply, E701
Aldc cable	Low voltage power supply, J704	Sideband exciter, J113
Cable (part of low voltage power supply.)	Low voltage power supply, J702	High voltage power supply, P401

25. Preoperational Check of Tubes, Fuses, and Crystals

The AN/FRT-53 is shipped with all tubes, fuses, and crystals installed. After the AN/FRT-53 has been installed, and before turning the transmitter on, perform the following checks:

a. *Tubes.* Refer to figures 20 through 26 to see that all tubes are correctly installed

in the proper sockets. (To reach the tubes, refer to the procedures given in paragraphs 54 and 55.)

b. *Fuses.* Be sure that fuses of the proper value are contained in the fuseholders of all the components of the AN/FRT-53. The following chart shows the value of each fuse and indicates its location:

Component	Panel marking and symbol	Rating (amp)	Figure reference
O-330B/FR	OVENS (F101)	3 ^a	12
	POWER (F102)	2 ^b	
Sideband exciter power supply	OVENS (F401)	2 ^b	14
	MAIN (F402)	3 ^a	
	B+ (F403)	.25	
Low voltage power supply	LINE (F301)	5	15
	BLOWER (F302)	2	
	LV. B- (F303)	0.1	
	M. V. B+ (F304)	0.25	
	UTILITY POWER (F501)	15	
Power distribution panel	UTILITY POWER (F502)	15	16

^a For 230-volt operation, change this fuse to 1.5 amperes.

^b For 230-volt operation, change this fuse to 1 ampere.

c. *Crystals.* Check to see that all crystals are correctly installed in the proper crystal sockets. Refer to the charts below. (To reach the crystals, refer to the procedures given in paragraph 56.)

(1) *O-330B/FR* (fig. 21 and 22).

Crystal function ^a	Crystal symbol
Bfo	Y101
Bfo	Y102
Hfo	Y202
Hfo	Y203
Hfo	Y204
Ifo	Y201

^aThe use of the O-330B/FR within the AN/FRT-53 configuration is limited to the vmo function. None of the above crystals is required for the operations detailed in this manual.

(2) *Sideband exciter* (fig. 27).

Crystal freq (mc)	Crystal socket
8	Y101
10	Y102
12	Y103
14	Y104
18	Y105
11	Y106
13	Y107
17	Y108

26. Initial Calibration of O-330B/FR

Note: Before the AN/FRT-53 is operated, perform the procedures given in this paragraph.

a. The high frequency output of the vmo in the O-330B/FR can be adjusted to any frequency between 2 and 4 mc. The MASTER OSCILLATOR FREQUENCY knob and the CALIBRATE control (fig. 11) are used when frequencies are changed. The procedures for setting the CALIBRATE control are detailed in c below.

b. The O-330B/FR requires a warmup period of at least 48 hours prior to its actual operation in the AN/FRT-53. Set the power distribution panel MAIN POWER circuit breaker to ON. Set the O-330B/FR POWER switch to ON and allow the necessary warmup time before making any adjustments.

c. After the initial warmup period, proceed as follows:

- (1) Set the BEAT and HFO switches to ON (fig. 11).
- (2) Plug a headset into the PHONES jack.
- (3) Turn the BAND-MCS switch to 2-4.
- (4) Turn the XTAL switch to VMO.
- (5) Turn the MASTER OSCILLATOR FREQUENCY knob until a reading of 2,000 kc is obtained in the KCS window; note whether the direction of approach to this frequency is from a higher reading to a lower reading or from a lower reading to a higher reading.
- (6) Loosen the LOCK knob behind the CALIBRATE control. Vary the CALIBRATE control until a zero beat null is obtained in the headset and on the ZERO BEAT panel lamp. (The ZERO BEAT lamp is normally lighted. As zero beat is approached, it will blink on and off erratically. At the zero beat, the lamp will be out.)
- (7) Turn the MASTER OSCILLATOR FREQUENCY knob until a reading of 4,000 kc is obtained in the KCS window; approach this frequency in the same direction as the 2,000-kc frequency was approached. (For example, if in the procedure in (5) above, 2,000 kc was approached from a higher frequency, turn the knob until a reading of over 4,000 kc is obtained; then set to 4,000 kc.)
- (8) Remove the front panel cap that covers trimmer C303 and adjust trimmer C303 with a screwdriver until a zero beat indication is obtained in the headset and on the ZERO BEAT lamp.
- (9) Repeat the procedure given in (5), (6), (7), and (8) above until adjustments of the CALIBRATE control and trimmer C303 produce a zero beat at both 2,000 and 4,000 kc. Tighten the CALIBRATE control knob and check to see that the adjustment has not been disturbed.
- (10) Replace the C303 trimmer cover.
- (11) Turn off the BEAT and HFO switches.

CHAPTER 3

OPERATION

Section I. CONTROLS, INDICATORS, AND CONNECTORS

Caution: Following an interval of transmission, be careful when deenergizing the rf amplifier. Turn off the FINAL VOLTAGES and TRANSMITTER VOLTAGES, wait at least 5 minutes and then set the MAIN POWER switch on the low voltage power supply to OFF. This procedure will leave the power amplifier (pa) blower on and permit the pa tube to cool, thus prolonging its life.

27. Rf Amplifier, Controls and Indicators

(fig. 9)

Control or indicator	Function	Control or indicator	Function
MULTI METER switch.	Connects meter to any one of eight circuits. <i>Sw pos Causes meter to read</i>	PA LOADING dial	Indicates setting of PA LOADING control.
PA DC:		PA LOADING switch.	Selects loading capacitor for connection across pa output circuit.
BIAS	Dc control grid voltage of pa tube.	DRIVER BAND switch.	Selects frequency range of tuned circuits in grid circuits of both driver and pa tubes.
SCREEN	Dc screen grid voltage of pa tube.	PA TUNING control.	Tunes output circuit of pa tube to desired frequency.
PLATE	Dc plate voltage of pa tube.	PA LOADING control.	Varies loading on pa stage.
SCREEN MA	Dc plate voltage of pa tube.	ALDC switch (fig. 10).	In INT position, causes dc output of aldc circuit to control gain of first amplifier tube. In EXT position, causes aldc output to control gain of sideband exciter.
RF:		NEUT control . . .	Adjusts neutralizing voltage applied to grid of pa tube.
1ST AMPL PLATE	Rf voltage of first amplifier tube.		
PA GRID	Rf voltage at control grid of pa tube.		
PA PLATE	Rf voltage at plate of pa tube.		
OUT	Rf voltage at output of rf amplifier.		
MULTI METER meter.	Indicates dc or rf voltage or dc current from circuit selected by MULTI-METER switch.		
PA PLATE CURRENT meter.	Measures plate current of pa tube.		
PA BAND switch..	Selects frequency range of pa output circuit.		
PA GRID TUNING control.	Tunes input circuit of pa tube.		
1ST AMPL TUNING control.	Simultaneously tunes tuned circuits in plate circuits of first amplifier and driver stages.		
PA TUNING dial..	Indicates setting of PA TUNING control		
ALDC control . . .	Sets level of aldc output voltage.		

Control or jack	Function
POWER switch ..	Turns O-330B/FR on and off.
HFO switch	Activates hfo ^a section.
IFO switch	Activates ifo ^b section.
BFO switch	Activates bfo ^c section.
BEAT switch	Activates 100-kc oscillator section.
METER switch ..	Connects meter to output of either hfo, ifo, bfo, or vmo section.
PHONES jack	With a headset, provides audible indication of zero beat during calibration.

28. O-330B/FR, Controls and Indicators

a. Subpanel Controls and Jacks (fig. 11).

^a High-frequency oscillator.
^b Intermediate frequency oscillator.
^c Beat frequency oscillator.

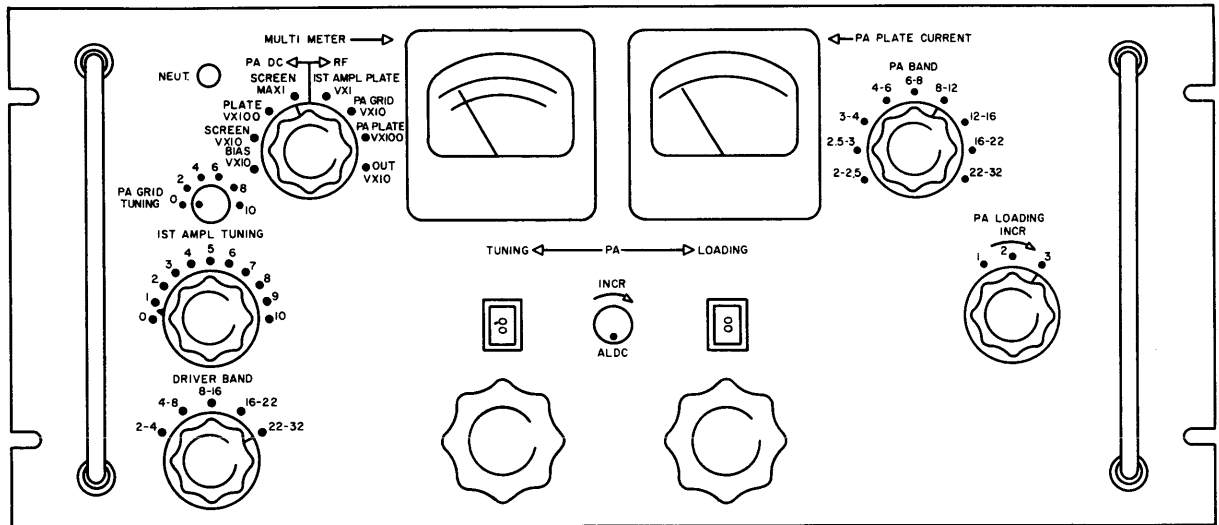

TM5820-472-12-19

Figure 9. Rf amplifier, controls and indicators.

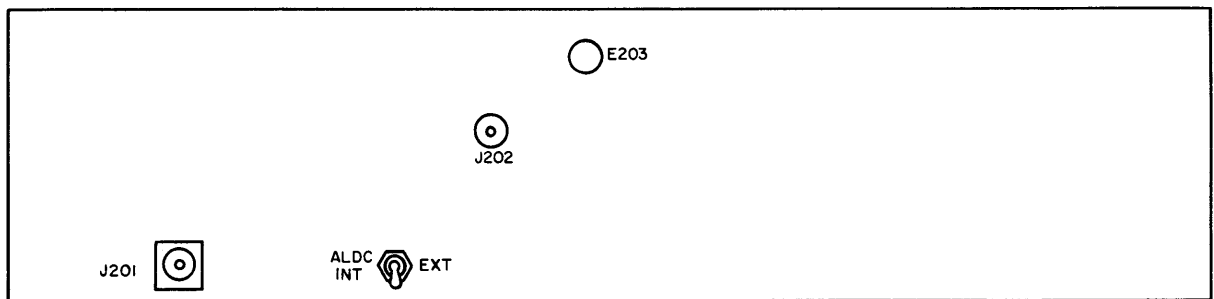

TM5820-472-12-31

Figure 10. Rf amplifier, rear panel.

b. Front Panel Controls and Indicators (fig. 11).

Control or indicator	Function
TUNING control	Tunes multiplier section of hfo.
OUTPUT control	Adjusts output voltage of hfo section.
BAND-MCS switch	Selects frequency range of hfo section output.
XTAL FREQ control	Trims hfo section crystals to exact frequency.
XTAL switch	Selects VMO operation or one of three crystal-controlled frequencies.
CALIBRATE control	Calibrates frequency of vmo at calibration checkpoints.
CALIBRATE LOCK control.	Locks CALIBRATE control.
Trimmer C303	Balances CALIBRATE control adjustment.

Control or indicator	Function
MASTER OSCILLATOR FREQUENCY control.	Controls output frequency of vmo section.
LOCK control	Locks MASTER OSCILLATOR FREQUENCY control.
MAIN POWER pilot lamp.	When lighted, indicates power to variable frequency oscillator is on.
INNER OVEN pilot light.	When lighted, indicates power is applied to inner oven.
OUTER OVEN pilot lamp.	When lighted, indicates power is applied to outer oven.
ZERO BEAT pilot lamp.	Provides visual indication of zero beat during calibration.
Meter	Indicates rf output voltage from circuit selected by METER switch.

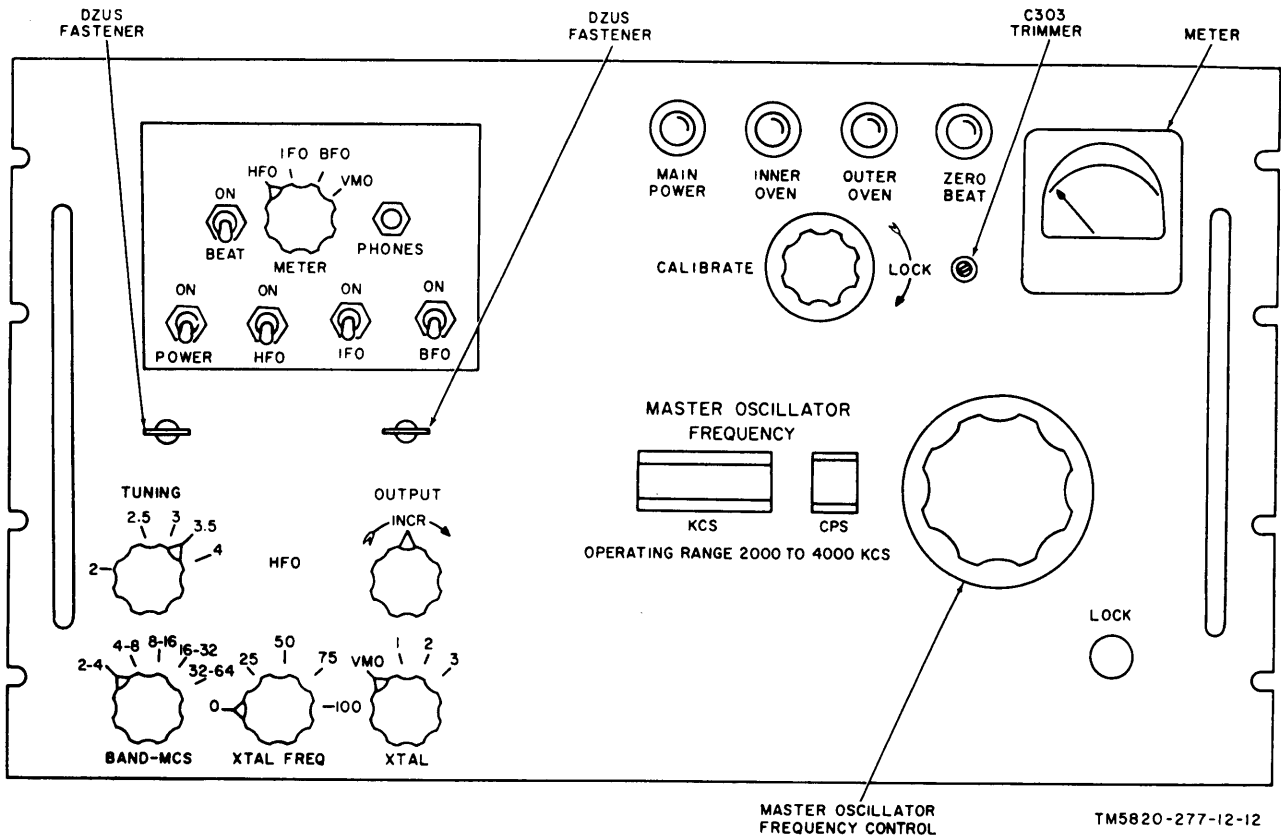

Figure 11. O-330B/FR, controls and indicators.

c. Rear Panel Controls and Jacks (fig. 12).

Controls and jacks	Function
Y101-Y102 switch	Selects crystal in the bfo section.
J102, J103, J104 jacks	Provide bfo outputs.
J205, J206, J207 jacks	Provide ifo outputs.
J208, J209, J210 jacks	Provide hfo outputs.
R116 control	Adjusts level of bfo output.
J106 jack	Provides connection for external headset.

29. Sideband Exciter, Controls and Indicators (fig. 13)

Control or indicator	Function
MF XTAL SW switch	In positions 1 through 10, connects corresponding internal crystal (when supplied) in oscillator circuit within 2- to 4-mc medium frequency range and simultaneously disables vmo input signal. In VMO position, permits injection of vmo signal from O-330B/FR and disables local crystal oscillator circuit.
Tuning dial	Two-section dial. Upper high-frequency multiscale section indicates setting of OUTPUT TUNING control. Lower mf single-scale section indicates setting of MF TUNING control.

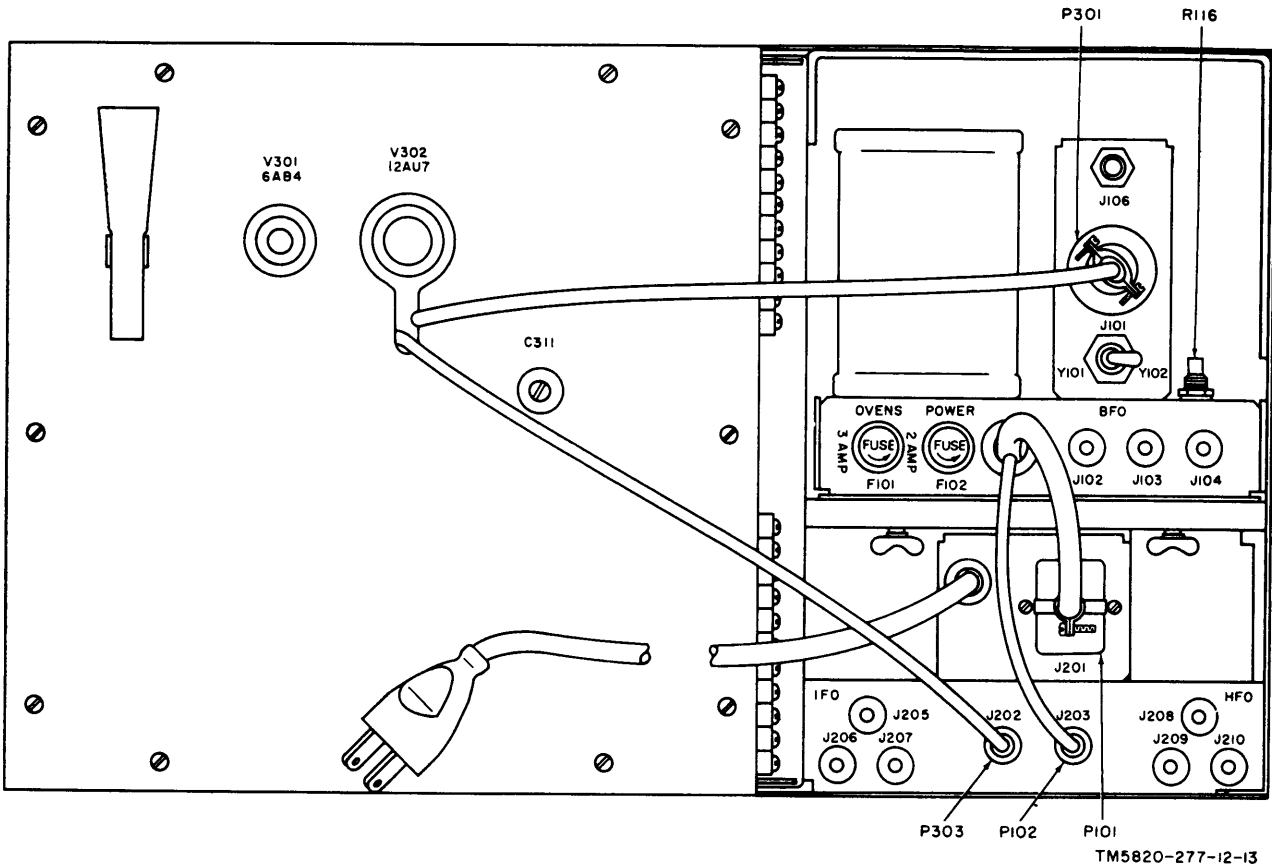

Figure 12. O-330B/FR, rear panel controls and jacks.

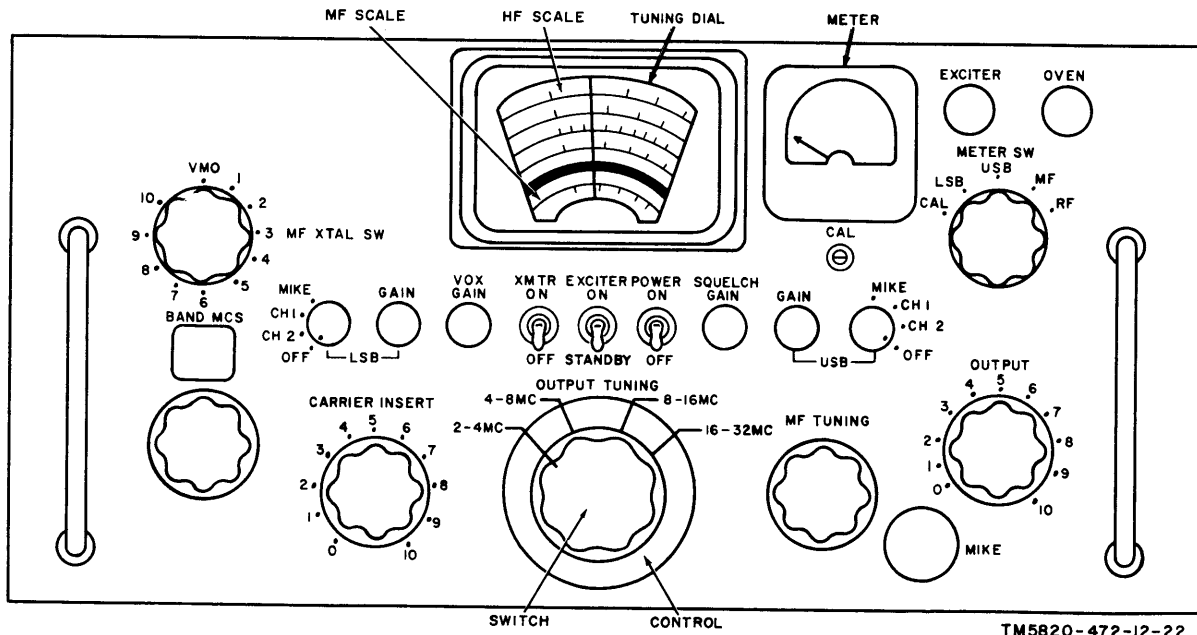
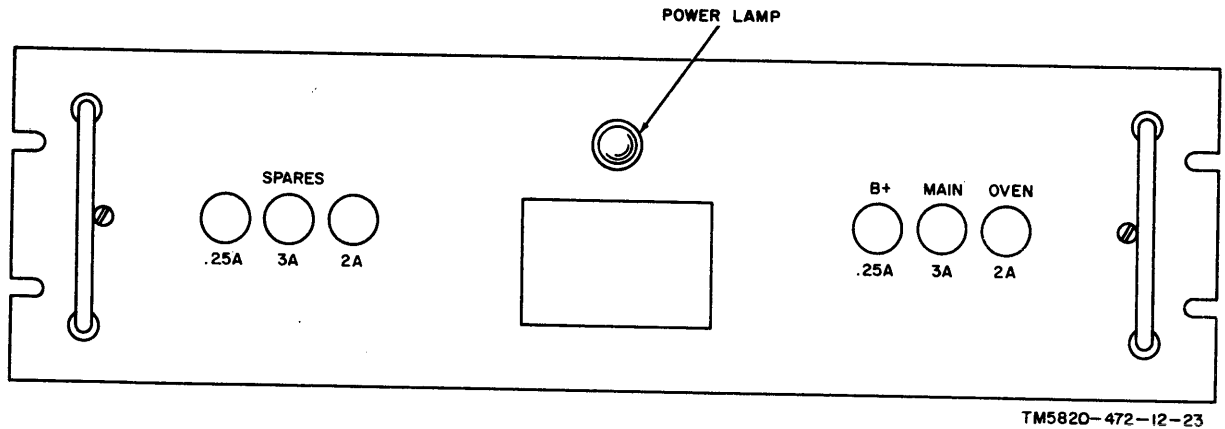

Figure 13. Sideband exciter, controls and indicators.



TM5820-472-12-23

Figure 14. Sideband exciter power supply, front panel.

31. Low Voltage Power Supply Controls and Indicators (fig. 15)

Control or indicator	Function
PA FIL PRI meter	Measures ac voltage applied to transformer primary windings.
PA FIL PRI ADJUST switch.	Controls ac voltage applied to transformer primary windings.
PA OVERLOAD PLATE circuit breaker.	Provides overload protection for pa plate supply circuit.
PA OVERLOAD SCR N GRID circuit breaker.	Provides overload protection for pa screen grid supply circuit.
PA OVERLOAD CONT GRID circuit breaker.	Provides overload protection for pa bias supply circuit.
FINAL VOLTAGES pilot lamp.	When lighted, indicates that plate and screen voltages are applied to pa stage in rf amplifier.
FINAL VOLTAGES switch.	In ON position, applies plate and screen voltages to pa stage in rf amplifier.
TRANSMITTER VOLTAGES pilot lamp.	When lighted, indicates that plate and screen voltages are applied to first amplifier and driver stages of rf amplifier.
TRANSMITTER VOLTAGES switch.	In ON position, applies plate and screen voltages to first amplifier and driver stages of rf amplifier. If FINAL VOLTAGES switch is left in ON position, TRANSMITTER VOLTAGES switch applies

Control or indicator	Function
MAIN POWER circuit breaker.	Turns power supply on and off
MAIN POWER pilot lamp.	When lighted, indicates power is applied to power supply.
L. V. B- indicator	When lighted, indicates a blown L. V. B- fuse.
M. V. B+ indicator	When lighted, indicates a blown M. V. B+ fuse.
LINE indicator	When lighted, indicates a blown LINE fuse.
BLOWER indicator	When lighted, indicates a blown BLOWER in fuse.

32. Power Distribution Panel, Control and Indicators (fig. 16).

Control or indicator	Function
UTILITY OUTLETS. receptacles.	Provide utility power.
MAIN POWER pilot lamp.	When lighted, indicates that ac power to AN/FRT-53 is turned on.
MAIN POWER circuit breaker.	Turns ac power on and off for all components of AN/FRT-53.
UTILITY POWER blown fus indicators (2).	When lighted, indicates that associated UTILITY POWER fuse is blown.

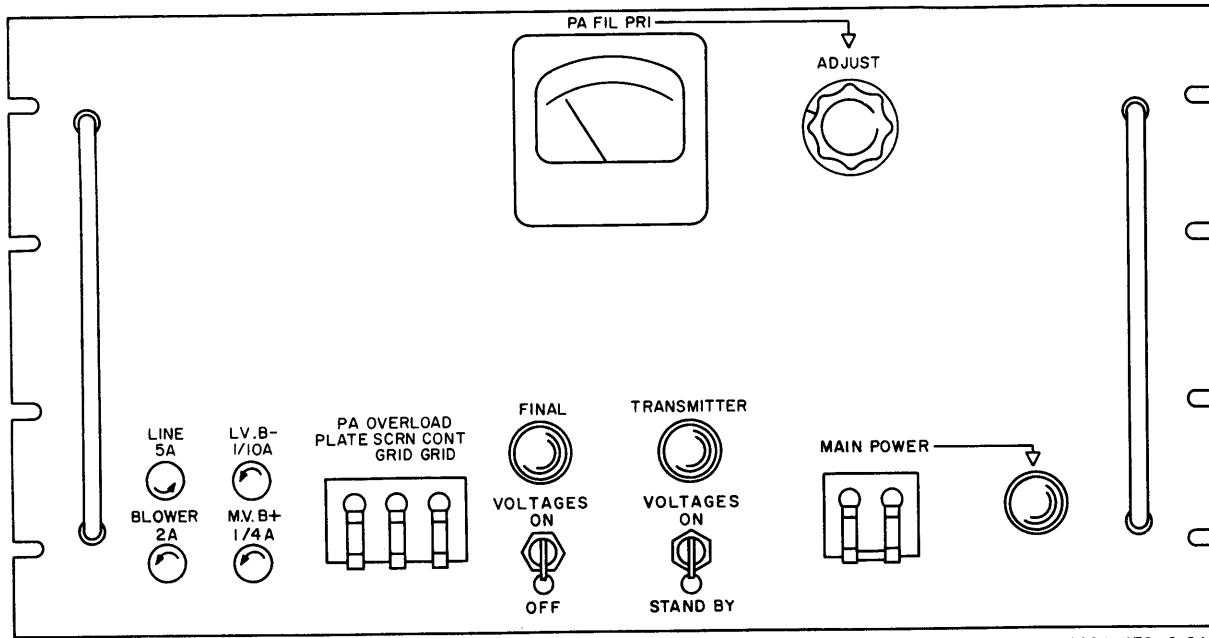

TM5820-472-12-24

Figure 15. Low voltage power supply, controls and indicators.

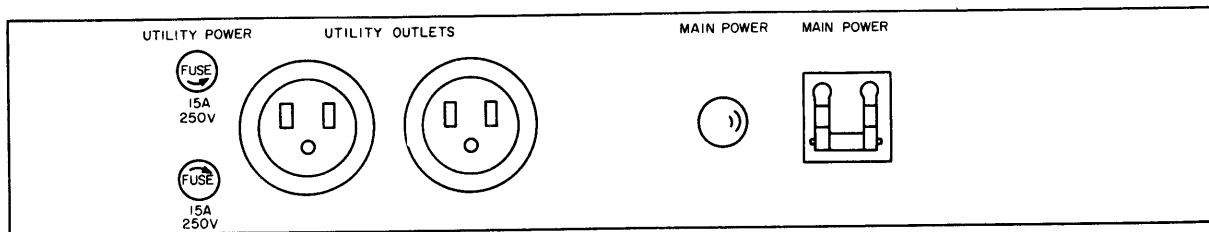

TM5820-472-12-25

Figure 16. Power distribution panel, front panel control and indicators.

Section II. OPERATING INSTRUCTIONS

33. Types of Operation

Radio Transmitting Set AN/FRT-53 may be operated to transmit ssb, dsb, isb, amplitude-modulated (am.), or cw telegraph signals. To operate the equipment in any mode, perform the following procedures:

- a. Preliminary starting procedure (para 34).
- b. Starting procedure (para 35).
- c. Sideband exciter tuning procedure (para 36).
- d. Sideband exciter operating procedure for the desired type of operation (para 37 through 41).

- e. Tuning procedure for the rf amplifier (para 42).
- f. Stopping procedure (para 43).

34. Preliminary Starting Procedures

- a. *Determination of Vmo Frequency.*
The medium frequency section of the sideband exciter receives its excitation from the O-330B/FR. Before operating the AN/FRT-53, determine the input frequency ((b) below) required from the O-330B/FR and set the controls on the sideband exciter as specified in (1) through (3) below:
 - (1) Operation between 2 and 4.25 mc.

To operate the AN/FRT-53 between 2 and 4.25 mc, set the BAND MCS and OUTPUT TUNING switches on the sideband exciter to the positions shown in the chart below. To determine the frequency setting of the O-330B/FR (vmo input signal), add 0.25 mc to, or subtract 0.25 mc from, the desired transmitter output frequency as indicated in the chart. For example, assume that an output frequency of 4.1 mc is desired:

Desired transmitter output frequency: 4.1 mc

Sideband exciter
BAND MCS switch setting: 2-4.25
Sideband exciter
OUTPUT TUNING switch setting: 2-8MC
O-330B/FR MASTER OSCILLATOR FREQUENCY dial setting: 3.85 mc (4.1 mc - 0.25 mc)

For other frequencies in the 2- to 4.25-mc range, refer to the chart below.

Desired transmitter output frequency range (mc)	BAND MCS switch setting	OUTPUT TUNING switch	Vmo frequency
2 to 3.73	2-4.25	2-4	$F_{\text{output}} + .25$
3.73 to 4.00	2-4.25	2-4	$F_{\text{output}} - .25$
4.00 to 4.25	2-4.25	4-8	$F_{\text{output}} - .25$

(2) Operation between 4.25 mc and 32.25 mc.

- Set the BAND MCS and OUTPUT TUNING switches to the range into which the operating frequency falls. (See chart below.)
- Note the multiplying factor N which appears under the frequency range markings on the BAND MCS dial.
- To determine the frequency setting of the O-330B/FR (vmo signal input), use the formula.

$$F_{vmo} = [(2 \times N) - f_{\text{output}}] + .25$$

Examples:

- Assume that an output frequency of 10.5 mc is desired:

Sideband exciter
BAND MCS switch setting: 10.25-12.25¹

Sideband exciter
OUTPUT TUNING switch setting: 8-16MC

O-330B/FR
MASTER OSCILLATOR FREQUENCY dial setting:

$$\begin{aligned} F_{vmo} &= [(2 \times 7) - 10.5] + .25 \\ &= [14 - 10.5] + .25 \\ &= 3.5 + .25 \\ &= 3.75 \text{ mc} \end{aligned}$$

- Assume that an output frequency of 26.8 mc is desired:

Sideband exciter
BAND MCS switch setting: 26.25-28.25¹

Sideband exciter
OUTPUT TUNING switch settings: 16.32MC

O-330B/FR
MASTER OSCILLATOR FREQUENCY dial setting:

$$\begin{aligned} F_{vmo} &= [(2 \times 15) - 26.8] + .25 \\ &= [30 - 26.8] + .25 \\ &= 3.2 + .25 \\ &= 3.45 \text{ mc} \end{aligned}$$

- Sideband exciter, switch settings. The range settings of the BAND MCS switch, the corresponding multiplying factors (N), and the associated settings of the OUTPUT TUNING switch are listed below.

¹ The multiplying factor 7 will appear under the frequency range markings on the BAND MCS dial.

¹ The multiplying factor 15 will appear under the frequency range markings on the BAND MCS dial.

BAND MCS switch setting	V _m multiplying factor N	OUTPUT TUNING switch setting
2-4	0	(See chart in (1) above).
4.25-6.25	4	4-8MC
6.25-8.25	5	4-8MC (for frequencies from 6.25 to 8.00 mc); 8-16MC (for frequencies from 8.00 to 8.25 mc)
8.25-10.25	6	8-16MC
10.25-12.25	7	8-16MC
12.25-14.25	8	8-16MC
14.25-16.25	9	8-16MC (for frequencies from 14.25 to 16.00 mc); 16-32MC (for frequencies from 16.00 to 16.25 mc)
16.25-18.25	10	16-32MC
18.25-20.25	11	16-32MC
20.25-22.25	12	16-32MC
22.25-24.25	13	16-32MC
24.25-26.25	14	16-32MC
26.25-28.25	15	16-32MC
28.25-30.25	16	16-32MC
30.25-32.25	17	16-32MC

b. Determination of Medium Frequency Crystal Frequency.

Note: Crystals Y111 through Y120 are not supplied as part of the AN/FRT-53. The O-330B/FR normally supplies the excitation signal to the medium frequency section of the sideband exciter. The procedure listed in this subparagraph should be used only when crystals rather than the vmo signal from the O-330B/FR are used for excitation.

- (1) **General.** The crystal to be used is selected by the MF XTAL SW switch (positions 1 through 10). When a crystal position is selected, the

Output frequency range (mc)	BAND MCS switch setting	OUTPUT TUNING switch	Crystal frequency
2 to 3.73	2-4.25	2-4MC	F _{output} + 0.25
3.73 to 4.00	2-4.25	2-4MC	F _{output} - 0.25
4.00 to 4.25	2-4.25	4-8MC	F _{output} - 0.25

(3) **Medium frequency crystal operation between 4.25 and 32.25 mc.**

- (a) Set the BAND MCS and OUTPUT TUNING switches to the range into which the desired output frequency falls. (See chart below.)
- (b) Note the multiplying factor N which appears under the fre-

vmo signal is automatically grounded and the output of the selected crystal is applied to the medium frequency section of the sideband exciter.

- (2) **Medium frequency crystal operation between 2 and 4.25 mc.** To determine the crystal frequency for operation between 2 and 4.25 mc, set the BAND MCS and the OUTPUT TUNING switches on the sideband exciter to the positions shown in the chart supplied with the equipment. Set the MF XTAL SW switch to the desired crystal position. To determine the crystal frequency required, add 0.25 mc to, or subtract 0.25 mc from, the desired transmitter output frequency as indicated in the chart. For example, assume that an output frequency of 4.1 mc is desired:

Desired transmitter output frequency: 4.1 mc

Sideband exciter
BAND MCS switch setting: 2-4.25

Sideband exciter
OUTPUT TUNING switch setting: 4-8MC

Crystal frequency required: 3.85 mc (4.1 - 0.25)

For other frequencies in the 2- to 4.25-mc range, refer to the chart below:

quency range markings on the BAND MCS dial.

- (c) Set the MF XTAL SW switch to the desired crystal position.
- (d) To determine the crystal frequency to use for a desired output frequency, use the formula:

$$F_{\text{crystal}} = [(2 \times N) - f_{\text{output}}] + .25$$

Example: Assume that an output frequency of 26.8 mc is desired:

Sideband exciter switch settings:

BAND-MCS: 26.25-28.25¹

OUTPUT TUN-

ING: 16-32MC

MF XTAL SW: Desired

crystal
position.

Crystal frequency required:

$$\begin{aligned}
 F_{\text{crystal}} &= [(2 \times 15) - 26.8] + .25 \\
 &= [30 - 26.8] + .25 \\
 &= 3.2 + .25 \\
 &= 3.45 \text{ mc}
 \end{aligned}$$

(4) *Medium frequency crystal chart.*

When crystals are used to generate the medium frequencies, a chart, supplied with the crystals, lists the assigned output frequencies and the required positions of the MF XTAL SW and BAND MCS switches. The chart may appear as follows:

Output frequency (mc)	MF XTAL SW switch position	BAND MCS switch position	Crystal frequency (mc)
3.5	1	2-4.25	3.75
5.25	2	4.25-6.25	3.0
7.0	3	6.25-8.25	3.25
11.75	4	10.25-12.25	2.50
15.1	5	14.25-16.25	3.15
19.5	6	18.25-20.25	2.75
22.0	7	20.25-22.25	2.25
23.2	8	22.25-24.25	3.05
26.8	9	26.25-28.25	3.45
30.25	10	28.25-30.25	2.0

c. *Preliminary Control Settings.* To insure frequency stability. The O-330B/FR should be left on at all times (MAIN POWER circuit breaker ON and the POWER switch on the O-330B/FR subpanel turned ON). If the AN/FRT-53 has been completely turned off when these procedures are started, in

addition to the preliminary control settings listed below, the MAIN POWER circuit breaker on the power distribution panel and the POWER switch on the O-330B/FR will be off.

Component	Control	Position
Rf amplifier	ALDC switch (rear panel)	OFF
Sideband exciter	POWER switch	OFF
	XMTR switch	OFF
	EXCITER switch	ON
	VOX GAIN control	Fully counterclockwise
	SQUELCH GAIN control	Fully counterclockwise
	LSB switch	OFF
	LSB GAIN control	Fully counterclockwise
	USB switch	OFF
	USB GAIN control	Fully counterclockwise
	MF XTAL SW switch	VMO
Low voltage power supply	OUTPUT control	Midposition
	PA FIL PRI ADJUST switch	Approximately one-quarter turn from fully counterclockwise
	FINAL VOLTAGES switch	OFF
	TRANSMITTER VOLTAGES switch	STANDBY
	MAIN POWER switch	OFF

35. Starting Procedure

Notes:

1. If an abnormal indication is obtained during the starting procedure, refer to the operational checklist (para 47) for corrective measures. With the controls set as directed in paragraph 34c, perform the following steps:

2. The calibration of the O-330B/FR (para 26) must be performed before the AN/FRT-53 is operated. Proceed to step 3 directly if the MAIN POWER circuit breaker on the power distribution panel is on and the O-330B/FR has been on for 48 hours or longer. If not, perform steps 1 and 2, wait 48 hours, and proceed to step 3.

Step	Component	Control or switch	Action	Indication
1	Power distribution panel.	MAIN POWER circuit breaker	Set to ON	MAIN POWER lamp on the power distribution panel lights and blowers in equipment rack go on.

¹The multiplying factor 15 will appear under the frequency range markings on the BAND MCS dial.

Step	Component	Control or switch	Action	Indication
2	O-330B/FR	POWER and HFO switches	Set to ON	MAIN POWER, INNER OVEN, and OUTER OVEN lamps light. (When the O-330B/FR ovens reach their normal operating temperatures, the INNER OVEN and OUTER OVEN lamps will cycle on for 5 seconds and off for 90 seconds.)
3	Sideband exciter	POWER switch	Set to ON	Power lamp on the sideband exciter power supply lights. OVEN lamp on the sideband exciter lights. After a few seconds, EXCITER lamp on sideband exciter lights.
4	Low voltage power supply	MAIN POWER circuit breaker	Set to ON	MAIN POWER lamp lights and the blowers in the rf amplifier chassis and the high voltage power go on.
5	Low voltage power supply	PA FIL PRI ADJUST switch	Adjust for 115-volt indication on PA FIL PRI meter.	PA FIL PRI meter indicates 115 volts

36. Sideband Exciter Tuning Procedure

a. Before the AN/FRT-53 can be tuned for a specific operating mode, the sideband exciter must be tuned to the rf carrier frequency supplied by the vmo section of the O-330B/FR. This procedure must also be performed when suppressed carrier operation is used. The sideband exciter is tuned to the carrier frequency; then one or both sidebands are generated by proper application of modulating signals as required by the particular operating mode. For cw telegraph operation, the sideband exciter is tuned to the carrier frequency and may be keyed by an externally connected telegraph key (para 23a) to produce cw signals.

b. The following tuneup procedure of the sideband exciter is based on transmission of an output carrier frequency of 26.8 mc. To produce this output frequency, the vmo should be set to 3.45 mc. Refer to paragraph 34 to determine how the vmo frequency is derived and for control settings of the sideband exciter for various output frequencies.

c. To tune the O-330B/FR to 3.45 mc, proceed as follows:

- (1) Set the BEAT switch (fig. 11) to ON.
- (2) Plug the headset into the PHONES jack.

- (3) Set the BAND-MCS switch to 2-4.
- (4) Set the XTAL switch to VMO.
- (5) Tune the MASTER OSCILLATOR FREQUENCY control to the check-out frequency ((6) below) closest to the desired frequency dial reading. In this case, tune the control to 3,450,000 since the exact check-point (45,000) appears in the list. Note the direction of rotation used in approaching the checkout frequency.

Note: Only the 2- to 4-mc band is used on the O-330B/FR when it is used as part of the AN/FRT-53. Refer to TM 11-5820-277-12 for operation of the O-330B/FR with other equipment.

- (6) In this list of checkout frequencies, the two left-hand digits of the dial reading are omitted. The last five digits listed holds true to any frequency from 2.0 to 4.0 mc.

-, -00,000	-, -50,000
-, -05,000	-, -55,000
-, -10,000	-, -60,000
-, -12,500	-, -66,667
-, -20,000	-, -71,428
-, -25,000	-, -75,000
-, -28,571	-, -80,000
-, -30,000	-, -83,333
-, -33,333	-, -85,714
-, -40,000	-, -90,000
-, -45,000	-, -95,000

- (7) Use the headset and the ZERO BEAT indicator and vary the CALIBRATE control for a zero beat. (At exact zero beat, the indicator should go out; near zero beat, it will flicker on and off.) At some checkout frequencies, zero beat indication will be obtained only from the headset and not from the ZERO BEAT indicator. When the CALIBRATE control is set on the zero beat point, use the LOCK knob to lock it in place.
- (8) Tune the MASTER OSCILLATOR FREQUENCY control to the desired operating frequency dial reading.

Note: For accurate calibration and resetability, rotate the MASTER OSCILLATOR FREQUENCY control in the same direction as directed in (5) above to prevent any error due to backlash in the gears.

- (9) Set the BEAT switch to the off (down) position.
 - (10) Turn the METER switch to HFO.
 - (11) Set the TUNING control to the position numerically closest to the MASTER OSCILLATOR FREQUENCY dial reading.
 - (12) Vary the OUTPUT control to obtain a one-quarter-scale (approximately) reading on the meter.
 - (13) Adjust the TUNING control for the highest meter reading obtainable.
 - (14) Adjust the OUTPUT control until an rf output level of 1.5 volts is indicated on the meter.
- d. To tune the sideband exciter to the rf carrier frequency, proceed as follows:
- (1) Rotate the BAND MCS switch until the associated BAND MCS indicator is set at 26.25-28.25.
 - (2) Rotate the CARRIER INSERT control to the 10 position.
 - (3) Set the METER SW switch to MF.
 - (4) Set the OUTPUT TUNING switch to 16-32MC.
 - (5) Rotate the OUTPUT TUNING control for a setting on the high frequency scale of the tuning dial (fig. 13) which is slightly lower than the selected carrier frequency; in this case, it is slightly less than 26.8 mc.

- (6) Rotate the MF TUNING control until a maximum indication is obtained on the meter. If necessary, decrease the setting of the CARRIER INSERT control to avoid an off-scale meter reading.

Note: The medium frequency scale of the tuning dial should now correspond with the vmo frequency supplied by the O-330E/FR (3.45 mc).

- (7) Set the METER SW switch to RF.
- (8) Increase the frequency setting of the OUTPUT TUNING control to the first peak reading obtainable on the meter.
- (9) If a specific output level of the rf carrier is desired, adjust the OUTPUT control until that level is obtained on the meter.

37. Tuning Sideband Exciter for Single-Sideband Operation

a. To tune the sideband exciter for ssb operation, first tune the rf circuits to the rf carrier frequency (para 36a); then inject the modulating signal input into either the lower or upper sideband. The sideband exciter provides the facilities for injecting either no carriage (for suppressed carrier operation) or any specified degree of carrier level. The modulating signal must be cabled to either the channel 1 or channel 2 inputs on terminal boards E501 and E502 of the power distribution panel (para 23) or may be applied as a microphone input at the MIKE jack on the front panel of the sideband carrier.

Note: This procedure assumes that the lower sideband is used, with a modulating signal applied at the channel 1 input terminals of the AN/FRT-53. To operate with a modulating signal from channel 2 or from a microphone, use the CH2 or MIKE setting respectively, of the LSB switch, rather than the CH1 setting specified in b below. To use the upper sideband rather than the lower sideband, use the USB switch and USB GAIN control rather than the corresponding LSB controls.

b. To tune the sideband exciter for ssb operation, perform the procedures described in paragraph 36; then operate the sideband exciter as follows:

- (1) Set the LSB switch to the CH 1

position and rotate the LSB GAIN control to approximately midposition. The USB switch should be set to OFF.

- (2) Rotate the CARRIER INSERT control to 0.
- (3) Set the METER SW switch to LSB. Adjust the LSB GAIN control until the meter indicates a maximum of 100 on audio peaks.

Note: When the METER SW switch is placed in the LSB, USB, or RF position, do not permit the meter peaks to exceed 100, since intermodulation distortion may become excessive beyond this point.

- (4) Set the METER SW switch to RF. Simultaneously, adjust the OUTPUT and CARRIER INSERT controls for the desired degree of carrier insertion. (The exact amount of carrier insertion is determined by the receiving equipment that is used to receive the transmitted signal.)

Note: For suppressed carrier operation, leave the CARRIER INSERT control in the 0 position. For any degree of carrier insertion, reduce the level of the audio peaks on the meter (using the OUTPUT control) by an amount equal to the carrier insertion desired; then return the level to 100 with the CARRIER INSERT control. For example: for 10-percent carrier injection (carrier down 20 decibels (db) from full power), set the OUTPUT control so that the meter reads 90 on audio peaks with the CARRIER INSERT control set to the 0 position; then rotate the CARRIER INSERT control clockwise until the meter reading rises from 90 to 100 on audio peaks.

- (5) Adjust the setting of the OUTPUT control so that the required sideband exciter level is obtained for operation of the transmitter. Be careful not to disturb the settings of the CARRIER INSERT or LSB GAIN controls.

38. Tuning Sideband Exciter for Double-Sideband Operation

a. To tune the sideband exciter of the AN/FRT-53 for dsb operation, tune the O-330B/FR and the sideband exciter to the

rf carrier frequency (para 36) and inject the modulating signal input into both the lower and upper sidebands.

Note: This procedure assumes that the audio modulating signal is connected to the channel 1 input of the power distribution panel. If operation from channel 2 or the MIKE input is desired use the corresponding CH 2 or MIKE settings of the LSB and USB switches rather than the CH 1 settings.

b. To tune the sideband exciter for dsb operation, proceed as follows:

- (1) Set the LSB switch to CH 1. Advance the LSB GAIN control 1/4-turn to the right (from maximum counterclockwise (ccw)).
- (2) Turn the CARRIER INSERT control to the 0 position.
- (3) Set the USB switch to OFF. Advance the USB GAIN control 1.4-turn to the right (from maximum ccw).
- (4) Set the METER SW switch to LSB.
- (5) Adjust the LSB GAIN control for the degree of carrier insertion required. For suppressed carrier operation, adjust this control so that the meter indicates 50 on audio peaks. For 10-percent carrier insertion, adjust this control so that the meter indicates 45 on audio peaks; for 20-percent carrier insertion, adjust this control so that the meter indicates 40 on audio peaks. For other values, decrease the meter reading by 5 for each 10-percent increase in carrier insertion.
- (6) Set the LSB switch to OFF and the USB switch to CH 1.
- (7) Set the METER SW switch to USB.
- (8) Adjust the USB GAIN control for the degree of carrier insertion required. For suppressed carrier operation, adjust this control so that the meter indicates 50 on audio peaks. For 10-percent carrier insertion, adjust this control so that the meter indicates 45 on audio peaks.
- (9) Set the METER SW switch to RF.
- (10) Advance the OUTPUT control from the 0 position to the position which causes the meter reading to be the same as that noted in (8) above.

- (11) Set the USB switch to OFF and the LSB switch to CH 1.
 - (12) Adjust the LSB GAIN control until the meter reading is the same as that noted in (5) above.
 - (13) Set the USB switch to CH 1. If the sideband levels were previously set for suppressed carrier operation, the meter should now read 100 on audio peaks. If set for 10-percent carrier insertion, the meter should read 90 on audio peaks.
 - (14) Adjust the CARRIER INSERT control so that the desired degree of carrier insertion is obtained. For suppressed carrier operation, leave this control in the 0 position. For 10-percent carrier insertion, turn the CARRIER INSERT control so that the peak readings on the meter rise from 90 to 100.
- (4) Set the METER SW switch to LSB.
 - (5) Adjust the LSB GAIN control for the degree of carrier insertion desired. For suppressed carrier operation, adjust this control so that the meter reads 50 on audio peaks. For 10-percent carrier injection, adjust this control so that the meter reads 45 on audio peaks. For other values, decrease the meter reading by 5 for each 10-percent increase in carrier insertion.
 - (6) Set the LSB switch to OFF and the USB switch to CH 2.
 - (7) Set the METER SW switch to USB.
 - (8) Adjust the USB GAIN control for the degree of carrier insertion desired. For suppressed carrier operation, adjust this control so that the meter reads 50 on audio peaks. For 10-percent carrier injection, adjust this control so that the meter reads 45 on audio peaks.
 - (9) Set the METER SW switch to RF.
 - (10) Rotate the OUTPUT control to the position that causes the meter reading to correspond to that obtained as instructed in (8) above.
 - (11) Set the USB switch to OFF and the LSB switch to CH 1.
 - (12) Note the reading on the meter. If necessary, readjust the LSB GAIN control until the meter reading is the same as that obtained as instructed in (5) above.
 - (13) Set the USB switch to CH 2. If the sideband levels were previously set for suppressed carrier operation, the meter reading should now be 100 on audio peaks. If set for 10-percent carrier insertion, the meter reading should now be 90 on audio peaks.
 - (14) Adjust the CARRIER INSERT control for the desired degree of carrier insertion. For suppressed carrier operation, leave this control in the 0 position. For 10-percent carrier insertion, turn the CARRIER INSERT control until the reading on the meter rises from 90 to 100 on audio peaks.

39. Tuning Sideband Exciter for Independent-Sideband Operation

a. To tune the sideband exciter for isb operation, tune the O-330B/FR and the sideband exciter to the rf carrier frequency (para 36) and inject one modulating signal into the lower sideband and another modulating signal into the upper sideband.

Note: This procedure assumes that the channel 1 modulating signal is injected into the lower sideband, and the channel 2 modulating signal is injected into the upper sideband. To switch the channel inputs, or to use the microphone input as one of the modulating signals, use the corresponding CH 1, CH 2, or MIKE settings of the LSB and USB switches.

b. To tune the sideband exciter for isb operation, proceed as follows:

- (1) Set the LSB switch to CH 1. Advance the LSB GAIN control one-quarter turn to the right (from maximum ccw).
- (2) Rotate the CARRIER INSERT control to the 0 position.
- (3) Set the USB switch to OFF. Advance the USB GAIN control one-quarter turn to the right (from maximum ccw).

40. Tuning Sideband Exciter for Amplitude Modulation

a. To tune the sideband exciter for am. operation, tune the O-330B/FR and the sideband exciter to the rf carrier frequency (para 36), and inject the modulating signal input into both the lower and upper sidebands. Except for the amount of carrier insertion, this operating procedure is similar to the dsb operation.

Note: This procedure assumes that the audio modulating signal is connected to the channel 1 input of the power distribution panel. If operation from channel 2 or the MIKE input is desired, use the corresponding CH 2 or MIKE settings of the LSB and USB switches rather than the CH 1 settings.

b. To tune the sideband exciter for conventional am. operation, proceed as follows:

- (1) Set the LSB switch to CH 1. Advance the LSB GAIN control one-quarter turn to the right (from maximum ccw).
- (2) Turn the CARRIER INSERT control to the 0 position.
- (3) Set the USB switch to OFF. Advance the USB GAIN control one-quarter turn to the right (from maximum ccw).
- (4) Set the METER SW switch to LSB.
- (5) Adjust the LSB GAIN control until the meter indicates 25 on audio peaks.
- (6) Set the LSB switch to OFF and the USB switch to CH 1.
- (7) Set the METER SW switch to USB.
- (8) Adjust the USB GAIN control until the meter indicates 25 on audio peaks.
- (9) Set the METER SW switch to RF.
- (10) Advance the OUTPUT control from 0 to the position that causes the meter reading to be the same as that obtained as instructed in (8) above.
- (11) Set the USB switch to OFF and the LSB switch to CH 1.
- (12) Note the meter reading. If necessary, adjust the LSB GAIN control until the meter reading is the same as that obtained as instructed in (5) above.

- (13) Set the USB switch to CH 1. The meter should now read 50 on audio peaks.
- (14) Adjust the CARRIER INSERT control so that the peak readings on the meter rise from 50 to 100. This adjustment corresponds to a carrier insertion level of 50 percent.

41. Tuning Sideband Exciter for Cw Operation

To tune the sideband exciter for cw telegraph operation, tune the O-330B/FR and the sideband exciter to the rf carrier frequency (para 36) and key the carrier on and off with an externally connected telegraph key (para 23d). To obtain cs operation, proceed as follows:

- a. Rotate the CARRIER INSERT control extremely clockwise.
- b. Set the LSB and USB switches to OFF.
- c. Set the METER SW switch to RF.
- d. With the telegraph key depressed, adjust the OUTPUT control until the proper rf output is obtained for driving the rf amplifier.

42. Tuning Procedure for Rf Amplifier

When the starting procedure has been performed (para 35) and the sideband exciter has been tuned for the desired mode of transmission, apply a modulating signal to the sideband exciter and operate the rf amplifier and the associated power supplies as follows:

- a. Set the PA BAND and DRIVER BAND switches on the rf amplifier for the frequency range into which the sideband exciter signal frequency falls. For example, if the sideband exciter has been tuned to 26.8 mc (as in the example presented in previous paragraphs), the PA BAND and DRIVER BAND switches should be set to 22-32 position.
- b. Set the MULTI METER switch on the rf amplifier to PA DC BIAS. The MULTI METER meter should indicate approximately -100 volts dc.
- c. Set the TRANSMITTER VOLTAGES switch on the low voltage power supply or the XMTR switch on the sideband exciter to ON. The TRANSMITTER VOLTAGES

lamp on the low voltage power supply should light.

d. Set the MULTI METER switch on the rf amplifier to RF 1ST AMPL PLATE. Rotate the OUTPUT control on the sideband exciter slightly clockwise.

e. Rotate the 1ST AMPL TUNING control on the rf amplifier until a peak indication is obtained on the MULTI METER meter. Adjust the OUTPUT control on the sideband exciter for an indication of 7 on the MULTI METER meter.

f. Set the MULIT METER switch to RF PA GRID. Adjust the PA GRID TUNING control until a peak indication is obtained on the MULTI METER meter.

g. Turn the OUTPUT control on the sideband exciter maximum ccw.

Note: The tuning charts will vary for each AN/FRT-53. The readings on these charts were prepared with the AN/FRT-53 connected to a dummy load. These readings will differ from those obtained when the equipment is in actual use.

h. Set the PA TUNING control to the setting shown in the tuning chart supplied with AN/FRT-53.

i. Set the PA LOADING switch to the setting shown in the tuning chart supplied with the AN/FRT-53.

j. Rotate the PA LOADING control to the setting shown in the tuning chart supplied with the AN/FRT-53.

k. Set the FINAL VOLTAGES switch on the low voltage power supply to ON. The FINAL VOLTAGES pilot lamp should light.

l. Slowly increase the setting of the OUTPUT control on the sideband exciter until the reading of the PA PLATE CURRENT meter on the rf amplifier is approximately 300 milliamperes. (With no modulation, plate current should be approximately 220 milliamperes.)

m. Adjust the PA TUNING control until a pronounced dip is produced on the PA PLATE CURRENT meter.

n. Adjust the setting of the PA LOADING control until the reading on the PA PLATE CURRENT meter rises.

o. Readjust the setting of the OUTPUT control on the sideband exciter until the reading on the PA PLATE CURRENT meter is 300 milliamperes.

p. Set the MULTI METER switch to RF OUT and note the level of rf output.

q. Repeat the procedure given in m through p above to increase the excitation until the desired power output is obtained.

Note: Full-rated power output will be obtained with approximately 400 to 450 milliamperes of plate current.

Caution: If the transmitter turns off automatically as a result of a temporary pa overload, reduce the sideband exciter output before turning on the associated circuit breaker.

43. Stopping Procedure

The AN/FRT-53 may be placed in standby or completely turned off. For standby, or when the off time of the AN/FRT-53 will not exceed 48 hours, the O-330B/FR should be left on to maintain maximum stability. The normal stopping procedure for the AN/FRT-53 takes at least 5 minutes. In an emergency, the entire AN/FRT-53 may be stopped immediately.

a. *Standby.* To place the AN/FRT-53 in standby operation, set the switches indicated in the chart below to the positions listed in the chart.

Component	Switch	Position
Low voltage power supply.	FINAL VOLTAGES TRANSMITTER VOLTAGES.	OFF STANDBY
Sideband exciter	XMTR EXCITER	OFF STANDBY

b. *Normal Stopping.* The normal stopping procedure for the AN/FRT-53 is listed in the chart below. Do not turn off the O-330B/FR unless the AN/FRT-53 is to remain off for more than 48 hours.

Caution: Wait at least 5 minutes from the time the FINAL VOLTAGES switch on the low voltage power supply and either the TRANSMITTER VOLTAGES switch on the low voltage power supply or the XMTR switch on the sideband exciter are turned off before turning off the MAIN POWER circuit breaker on the low voltage power supply. This delay will gradually cool the pa tube in the rf amplifier chassis.

Component	Control	Position
Low voltage power supply	FINAL VOLTAGES switch	OFF
	TRANSMITTER VOLTAGES switch	STANDBY
Sideband exciter	XMTR switch	OFF
Low voltage power supply	MAIN POWER circuit breaker	OFF
Sideband exciter	POWER switch	OFF
O-330E/FR	POWER switch	Off ^a
Power distribution panel	MAIN POWER circuit breaker	Off ^a

^aTurn off only if the transmitter-off time will exceed 48 hours.

c. *Emergency Stopping.* To turn off the AN/FRT-53 in an emergency, set the MAIN POWER circuit breaker on the power distribution panel to off.

CHAPTER 4

MAINTENANCE INSTRUCTIONS

Section I. OPERATOR'S MAINTENANCE

44. Scope of Operator's Maintenance

The following maintenance duties are normally performed by the operator of the AN/FRT-53. These procedures do not require special tools or test equipment.

- a. Preventive maintenance (para 45).
- b. Visual inspection (para 46).
- c. Operational checks (para 47).
- d. Replacement of pilot lamps and fuses (para 48).

45. Preventive Maintenance

a. *DA Form 11-238.* DA Form 11-238 (fig. 17) is a preventive maintenance checklist to be used by the operator. Items not applicable to the AN/FRT-53 are lined out in the figures. Instructions for using the form appear on the form.

b. *Items.* The information shown in the chart below is supplementary to DA Form 11-238. The item numbers correspond to the ITEM numbers on the form.

Item	Maintenance procedure
1	Refer to the table of components (para 6) for a complete listing of the equipment and running spares.
2	Use a clean cloth to remove dust, dirt, moisture, and grease from the front panel controls, and component panels. If necessary, wet the cloth with Cleaning Compound (Federal stock No. 7930-395-9542) and then wipe the parts with a dry, clean cloth.
3	All control knobs should work smoothly, be tight on the shaft, and should not bind. Tighten all loose knobs and be sure that the knobs do not rub against the component panels.
5	Use a clean cloth to remove dust and dirt from equipment rack. Turn off the power before cleaning near the antenna connector.
6	Remove rust from rack-mounted components.
11	To gain access to the air filter in the high voltage power supply, turn the Dzus fasteners on the front panel access door and open the door.

Warning: Cleaning compound is flammable and its fumes are toxic. Do not use near a flame; provide adequate ventilation.

46. Visual Inspection

a. When the equipment fails to perform properly, turn off the power and check all the items listed below.

Caution: Do not check any item with the power on.

- (1) Wrong settings of switches and controls (para 27 through 32).
- (2) Interlock switch open because component in equipment rack is not properly seated.
- (3) Burned-out fuses (usually indicates some other fault).

Caution: Do not replace a fuse with one of a higher rating. If a fuse burns out immediately after replacement, DO NOT replace it again. Troubleshooting at higher echelon is necessary.

b. If the above checks do not locate the trouble, proceed to the operational checklist (para 47).

47. Operational Checklist

a. *General.* The operational checklist consists of preliminary starting and operating procedures and is supplemented by the operator's repair procedures (para 48). The corrective measures listed are those the operator can perform. When no corrective measures are listed or if the measures suggested do not restore normal equipment performance, troubleshooting is required by higher echelon personnel. Note on the repair tag what corrective measures were taken, and how the equipment performed at the time of failure.

b. *Procedure.* To check the operation of the equipment, set the front panel controls as indicated in paragraph 35 and perform the steps listed below. Do not proceed with later steps until abnormal condition is corrected.

LEGEND for marking conditions: Satisfactory, ✓ Adjustment, Repair or Replacement required, X. Defect corrected, ⊗.		DAILY CONDITION FOR MONTH OF MARCH 1962												2D ECH- ELON				
		1	2	3	4	5	6	7	8	9	10	11	12		13	14	15	16
NO. DAILY ITEM	1. COMPLETENESS AND GENERAL CONDITION OF EQUIPMENT. (Transmitters, receivers, carrying cases, wire, cables, microphones, tubes, spare parts, technical manuals).	17	18	19	20	21	22	23	24	25	26	27	28	29	30	31		
		18	19	20	21	22	23	24	25	26	27	28	29	30	31			
		19	20	21	22	23	24	25	26	27	28	29	30	31				
		20	21	22	23	24	25	26	27	28	29	30	31					
NO. WEEKLY	2. CLEAN DIRT AND MOISTURE FROM ANTENNA, MICRO- PHONES, HEADSETS, KEYS, JACKS, PLUGS, COMPONENT PANELS.	1	2	3	4	5	6	7	8	9	10	11	12	13	14	15	16	
		2	3	4	5	6	7	8	9	10	11	12	13	14	15	16		
		3	4	5	6	7	8	9	10	11	12	13	14	15	16			
		4	5	6	7	8	9	10	11	12	13	14	15	16				
NO. WEEKLY	3. INSPECT CONTROLS FOR NORMAL OPERATION. TAP CONTROLS LIGHTLY FOR EVIDENCE OF CUT-OUT FROM LOOSE CONTACTS.	1	2	3	4	5	6	7	8	9	10	11	12	13	14	15	16	
		2	3	4	5	6	7	8	9	10	11	12	13	14	15	16		
		3	4	5	6	7	8	9	10	11	12	13	14	15	16			
		4	5	6	7	8	9	10	11	12	13	14	15	16				
NO. WEEKLY	4. CHECK FOR NORMAL OPERATION OF EQUIPMENT. BE ALERT FOR UNUSUAL OPERATION OR CONDITION.	1	2	3	4	5	6	7	8	9	10	11	12	13	14	15	16	
		2	3	4	5	6	7	8	9	10	11	12	13	14	15	16		
		3	4	5	6	7	8	9	10	11	12	13	14	15	16			
		4	5	6	7	8	9	10	11	12	13	14	15	16				
NO. WEEKLY	5. CLEAN AND TIGHTEN EXTERIORS OF CASES, RACKS, MOUNTS, TRANSMISSION LINES.	1	2	3	4	5	6	7	8	9	10	11	12	13	14	15	16	
		2	3	4	5	6	7	8	9	10	11	12	13	14	15	16		
		3	4	5	6	7	8	9	10	11	12	13	14	15	16			
		4	5	6	7	8	9	10	11	12	13	14	15	16				
NO. WEEKLY	6. INSPECT CASES, MOUNTS, ANTENNA TOWERS AND EXPOSED METAL SURFACES FOR RUST, CORROSION.	1	2	3	4	5	6	7	8	9	10	11	12	13	14	15	16	
		2	3	4	5	6	7	8	9	10	11	12	13	14	15	16		
		3	4	5	6	7	8	9	10	11	12	13	14	15	16			
		4	5	6	7	8	9	10	11	12	13	14	15	16				
NO. WEEKLY	7. INSPECT CORDS, CABLE, WIRE, SHOCK MOUNTS FOR CUTS, KINKS, BREAKS, FRAVING, UNDUCE STRAIN.	1	2	3	4	5	6	7	8	9	10	11	12	13	14	15	16	
		2	3	4	5	6	7	8	9	10	11	12	13	14	15	16		
		3	4	5	6	7	8	9	10	11	12	13	14	15	16			
		4	5	6	7	8	9	10	11	12	13	14	15	16				
NO. WEEKLY	8. CHECK ANTENNA CUV-WIRES FOR -PROPER TENSION OR DAMAGE.	1	2	3	4	5	6	7	8	9	10	11	12	13	14	15	16	
		2	3	4	5	6	7	8	9	10	11	12	13	14	15	16		
		3	4	5	6	7	8	9	10	11	12	13	14	15	16			
		4	5	6	7	8	9	10	11	12	13	14	15	16				
NO. WEEKLY	9. INSPECT CANNAS AND LEATHER ITEMS FOR INDETERMINATE FRAYING.	1	2	3	4	5	6	7	8	9	10	11	12	13	14	15	16	
		2	3	4	5	6	7	8	9	10	11	12	13	14	15	16		
		3	4	5	6	7	8	9	10	11	12	13	14	15	16			
		4	5	6	7	8	9	10	11	12	13	14	15	16				
NO. WEEKLY	10. INSPECT ACCESSIBLE ITEMS FOR LOOSE- NESS: SWITCHES, KNOBS, JACKS, CONNECTORS, RELAYS, TRANSFORMERS, MOTORS, PILOT LIGHTS, BLOWERS, ETC.	1	2	3	4	5	6	7	8	9	10	11	12	13	14	15	16	
		2	3	4	5	6	7	8	9	10	11	12	13	14	15	16		
		3	4	5	6	7	8	9	10	11	12	13	14	15	16			
		4	5	6	7	8	9	10	11	12	13	14	15	16				
NO. WEEKLY	11. CLEAN AND/OR INSPECT AIR FILTERS, BRASS NAME PLATES, DIAL AND METER WINDOWS.	1	2	3	4	5	6	7	8	9	10	11	12	13	14	15	16	
		2	3	4	5	6	7	8	9	10	11	12	13	14	15	16		
		3	4	5	6	7	8	9	10	11	12	13	14	15	16			
		4	5	6	7	8	9	10	11	12	13	14	15	16				
NO. WEEKLY	12. INSPECT STORAGE BATTERIES FOR DIRT-LOOSE TERMINALS-REPAIR OR WITH-DRAWED-CHARGE. -INSPECT DRY BATTERIES FOR LEAKAGE.	1	2	3	4	5	6	7	8	9	10	11	12	13	14	15	16	
		2	3	4	5	6	7	8	9	10	11	12	13	14	15	16		
		3	4	5	6	7	8	9	10	11	12	13	14	15	16			
		4	5	6	7	8	9	10	11	12	13	14	15	16				
NO. WEEKLY	ADDITIONAL ITEMS FOR 2D AND 3D ECHELON INSPECTIONS	1	2	3	4	5	6	7	8	9	10	11	12	13	14	15	16	
		2	3	4	5	6	7	8	9	10	11	12	13	14	15	16		
		3	4	5	6	7	8	9	10	11	12	13	14	15	16			
		4	5	6	7	8	9	10	11	12	13	14	15	16				
NO. WEEKLY	ADDITIONAL ITEMS FOR 2D AND 3D ECHELON INSPECTIONS	1	2	3	4	5	6	7	8	9	10	11	12	13	14	15	16	
		2	3	4	5	6	7	8	9	10	11	12	13	14	15	16		
		3	4	5	6	7	8	9	10	11	12	13	14	15	16			
		4	5	6	7	8	9	10	11	12	13	14	15	16				
NO. WEEKLY	ADDITIONAL ITEMS FOR 2D AND 3D ECHELON INSPECTIONS	1	2	3	4	5	6	7	8	9	10	11	12	13	14	15	16	
		2	3	4	5	6	7	8	9	10	11	12	13	14	15	16		
		3	4	5	6	7	8	9	10	11	12	13	14	15	16			
		4	5	6	7	8	9	10	11	12	13	14	15	16				
NO. WEEKLY	ADDITIONAL ITEMS FOR 2D AND 3D ECHELON INSPECTIONS	1	2	3	4	5	6	7	8	9	10	11	12	13	14	15	16	
		2	3	4	5	6	7	8	9	10	11	12	13	14	15	16		
		3	4	5	6	7	8	9	10	11	12	13	14	15	16			
		4	5	6	7	8	9	10	11	12	13	14	15	16				
NO. WEEKLY	ADDITIONAL ITEMS FOR 2D AND 3D ECHELON INSPECTIONS	1	2	3	4	5	6	7	8	9	10	11	12	13	14	15	16	
		2	3	4	5	6	7	8	9	10	11	12	13	14	15	16		
		3	4	5	6	7	8	9	10	11	12	13	14	15	16			
		4	5	6	7	8	9	10	11	12	13	14	15	16				
NO. WEEKLY	ADDITIONAL ITEMS FOR 2D AND 3D ECHELON INSPECTIONS	1	2	3	4	5	6	7	8	9	10	11	12	13	14	15	16	
		2	3	4	5	6	7	8	9	10	11	12	13	14	15	16		
		3	4	5	6	7	8	9	10	11	12	13	14	15	16			
		4	5	6	7	8	9	10	11	12	13	14	15	16				
NO. WEEKLY	ADDITIONAL ITEMS FOR 2D AND 3D ECHELON INSPECTIONS	1	2	3	4	5	6	7	8	9	10	11	12	13	14	15	16	
		2	3	4	5	6	7	8	9	10	11	12	13	14	15	16		
		3	4	5	6	7	8	9	10	11	12	13	14	15	16			
		4	5	6	7	8	9	10	11	12	13	14	15	16				
NO. WEEKLY	ADDITIONAL ITEMS FOR 2D AND 3D ECHELON INSPECTIONS	1	2	3	4	5	6	7	8	9	10	11	12	13	14	15	16	
		2	3	4	5	6	7	8	9	10	11	12	13	14	15	16		
		3	4	5	6	7	8	9	10	11	12	13	14	15	16			
		4	5	6	7	8	9	10	11	12	13	14	15	16				
NO. WEEKLY	ADDITIONAL ITEMS FOR 2D AND 3D ECHELON INSPECTIONS	1	2	3	4	5	6	7	8	9	10	11	12	13	14	15	16	
		2	3	4	5	6	7	8	9	10	11	12	13	14	15	16		
		3	4	5	6	7	8	9	10	11	12	13	14	15	16			
		4	5	6	7	8	9	10	11	12	13	14	15	16				
NO. WEEKLY	ADDITIONAL ITEMS FOR 2D AND 3D ECHELON INSPECTIONS	1	2	3	4	5	6	7	8	9	10	11	12	13	14	15	16	
		2	3	4	5	6	7	8	9	10	11	12	13	14	15	16		
		3	4	5	6	7	8	9	10	11	12	13	14	15	16			
		4	5	6	7	8	9	10	11	12	13	14	15	16				
NO. WEEKLY	ADDITIONAL ITEMS FOR 2D AND 3D ECHELON INSPECTIONS	1	2	3	4	5	6	7	8	9	10	11	12	13	14	15	16	
		2	3	4	5	6	7	8	9	10	11	12	13	14	15	16		
		3	4	5	6	7	8	9	10	11	12	13	14	15	16			
		4	5	6	7	8	9	10	11	12	13	14	15	16				
NO. WEEKLY	ADDITIONAL ITEMS FOR 2D AND 3D ECHELON INSPECTIONS	1	2	3	4	5	6	7	8	9	10	11	12	13	14	15	16	
		2	3	4	5	6	7	8	9	10	11	12	13	14	15	16		
		3	4	5	6	7	8	9	10	11	12	13	14	15	16			
		4	5	6	7	8	9	10	11	12	13	14	15	16				
NO. WEEKLY	ADDITIONAL ITEMS FOR 2D AND 3D ECHELON INSPECTIONS	1	2	3	4	5	6	7	8	9	10	11	12	13	14	15	16	
		2	3	4	5	6	7	8	9	10	11	12	13	14	15	16		
		3	4	5	6	7	8	9	10	11	12	13	14	15	16			
		4	5	6	7	8	9	10	11	12	13	14	15	16				
NO. WEEKLY	ADDITIONAL ITEMS FOR 2D AND 3D ECHELON INSPECTIONS	1	2	3	4	5	6	7	8	9	10	11	12	13	14	15	16	
		2	3	4	5	6												

Note: When input power is applied to the AN/FRT-53 (MAIN POWER lamp on the power distribution panel is lighted) and the O-330B/FR is on (MAIN POWER lamp on O-330B/FR is lighted) and OUTER OVEN and INNER OVEN pilot lamps on

O-330B/FR are cycling on and off normally, proceed to step 4 directly. If the MAIN POWER pilot lamp and both the OUTER OVEN and INNER OVEN pilot lamps on the O-330B/FR are off, proceed with step 1.

c. Checklist.

Action	Normal indication	Corrective measure
1. Turn on MAIN POWER circuit breaker on power distribution panel.	MAIN POWER lamp on power distribution panel lights and equipment rack blower fans go on.	Check to see that power is applied from the station's power distribution system.
2. Turn POWER switch on O-330B/FR to ON.	MAIN POWER lamp on O-330B/FR lights. OUTER OVEN and INNER OVEN lamps light.	Check MAIN POWER lamp. Check MAIN POWER lamp. Check OUTER OVEN and INNER OVEN lamps.
3. Determine vmo frequency required for operation at the desired output frequency (para 34a). Tune O-330B/FR to this frequency (para 36c).		
4. Turn POWER switch on sideband exciter to ON.	Power lamp on the sideband exciter power supply lights. OVEN lamp on sideband exciter lights.	Check power lamp. Check MAIN fuse on sideband exciter power supply. Check OVEN lamp. Check OVEN fuse on sideband exciter power supply.
5. Turn EXCITER switch on sideband exciter to ON.	EXCITER lamp on sideband exciter lights.	Check EXCITER lamp. Check B+ fuse on sideband exciter power supply.
6. Tune sideband exciter to carrier frequency (para 36d).		
7. Set MAIN POWER circuit breaker on low voltage power supply to ON.	MAIN POWER lamp on low voltage power supply lights. Blower in rf amplifier goes on. Blower in high voltage power supply goes on.	Check MAIN POWER lamp. Check LINE fuse on low voltage power supply. Check BLOWER fuse on low voltage power supply.
8. Set the MULTI METER switch on the rf amplifier to PA DC BIAS.	MULTI METER meter indicates -100 volts dc.	Check that door interlock on high voltage power supply is closed.
9. After at least 3 minutes, turn TRANSMITTER VOLTAGES switch on low voltage power supply to ON.	TRANSMITTER VOLTAGES lamp lights.	Check TRANSMITTER VOLTAGES lamp.
10. Tune driver stages of rf amplifier (para 42a through j).		Check L. V. B- and M. V. B+ fuses on the low voltage power supply.
11. Set FINAL VOLTAGES switch on low voltage power supply to ON.	FINAL VOLTAGES lamp on low voltages power supply lights.	Check to see that access door on front panel of high voltage power supply is firmly closed and that top and bottom covers of rf amplifier are securely in place.
12. Tune final power amplifier (para 42l through q).	Full-rated output is obtained at desired frequency.	Check to see that PA OVERLOAD PLATE and PA OVERLOAD SCRNL GRID circuit breakers are on. Reset if necessary. If circuit breakers go off again, higher echelon repair is required. Check FINAL VOLTAGES lamp.

48. Operator's R pairs

a. Replacement of Pilot Lamps.

- (1) Turn the glass pilot lamp jewel counterclockwise and pull it out to expose the pilot lamp.
- (2) Press in on the lamp and turn it counterclockwise to unlock.
- (3) Remove the lamp and replace it with a new one. Push the new lamp in and twist it clockwise to lock.
- (4) Replace the glass pilot lamp jewel and turn it clockwise to lock.

b. Replacement of Fuses.

- (1) Press in on the fuseholder cap and turn it counterclockwise to unlock.
- (2) Remove the fuseholder cap.
- (3) Remove the fuse from the fuseholder and replace it with a spare fuse.

Caution: Always replace a fuse with one of identical value. The equipment may become damaged by the use of an improper fuse.

- (4) Replace the fuseholder cap and turn it clockwise to lock.

Section II. SECOND ECHELON MAINTENANCE

49. Scope of Second Echelon Maintenance

The following maintenance duties are performed by second echelon personnel:

- a. Preventive maintenance (para 51).
- b. Visual inspection (para 52).
- c. Equipment performance checks (para 53).
- d. Replacement of components (para 54).
- e. Replacement of tubes (para 55).
- f. Replacement of crystals (para 56).
- g. Replacement of sideband exciter tuning dial lamp (para 57).

Items not applicable to the equipment are lined out. For additional preventive maintenance information concerning items 1 through 12 on DA Form 11-238, refer to paragraph 45b.

Warning: Obtain permission to disconnect all power before performing the operations listed in DA Form 11-238. When power to the equipment is disconnected, some capacitors may retain dangerous voltages. Before touching any exposed electrical parts, short-circuit the part to ground.

b. The information in the chart below is supplementary to DA Form 11-238. The item numbers correspond to ITEM numbers on the form.

50. Test Equipment, Tools, and Materials Required

a. Test Equipment and Tools.

- (1) Audio Oscillator TS-382A/U.
- (2) Test Set, Electron Tube TV-7/U.
- (3) Multimeter ME-26B/U.
- (4) Headset HS-33A.
- (5) Tool Kit TK-87/U.

b. Materials.

- (1) Cleaning Compound (FSN 7930-395-9542).
- (2) Cleaning cloth.
- (3) Lubricating oil, general purpose (LO) (FSN 9150-252-6173).

Item	Maintenance procedures
11	The air filters should be cleaned once every 3 months. Remove the air filters (para 54d) and clean as follows: Use blowers to blow out dust. Pour cleaning compound over the filter. Place a large basin under the filter to catch the compound. After the dirt particles settle, the clear compound can be re-used. Use a light water spray to flush out the loosened dirt. After the filter is dry, spray oil (LO) <i>very sparingly</i> on the side of the filter that faces the flow of air. To prevent oil from being spread throughout the equipment by air suction, avoid using excess oil.
15	Be sure that the tubes, crystals, and relays are firmly seated in their sockets.

51. Preventive Maintenance

a. DA Form 11-238 (fig. 18 and 19) is a preventive maintenance checklist for use by organizational maintenance personnel.

Item	Maintenanc procedures
19	Tighten screws, bolts, and nuts carefully. Fittings tightened beyond the pressure for which they were designed will become damaged or broken.

Warning: Cleaning compound is flammable and its fumes are toxic. Do not use near a flame; provide adequate ventilation.

52. Visual Inspection

Before performing the procedures given in the equipment performance checklist (para 53), the organizational repairman should visually inspect the AN/FRT-53. In addition to the items listed in paragraph 46, inspect the items given below for obvious defects:

Caution: Do not inspect any item with the power on.

- a. Disconnected cables or plugs between units of the AN/FRT-53.
- b. Interlock switch connections.
- c. Terminal board connections.
- d. Chassis wiring and parts (for burned insulation).

Note: Refer to figures 20 through 26 for the tube locations and figures 21, 22, and 27 for crystal location.

	Step	Unit	Action	Normal indication	Corrective measur s
P R E P A R A T O R Y	1	Low voltage power supply.	Set FINAL VOLTAGES switch to OFF. Set TRANSMITTER VOLTAGES switch to STAND BY. Set MAIN POWER circuit breaker to off position.		
	2	Sideband exciter	Set XMTR switch to OFF. Set EXCITER switch to STANDBY. Set POWER switch to OFF. Set MF XTAL SW switch to VMO. Set BAND MCS switch to 26.25-28.25 (15). Set OUTPUT TUNING switch to 16-32MC. Rotate VOX GAIN and SQUELCH GAIN controls maximum counterclockwise. Set LSB and USB switches to OFF.		

53. Equipment Performance Checklist

a. *General.* The equipment performance checklist is a procedure used to systematically check equipment performance. All corrective measures which organizational repairmen can perform are given in the *Corrective measures* column. All pilot lamps and all fuses (except the OVENS and POWER fuses on the rear panel of the O-330B/FR) are assumed to have been checked by the operator and are *not* listed in the *Corrective measures* column of this checklist. When using the checklist, follow each step in the order given. If the corrective measures indicated do not restore normal performance, or no corrective measures indicated do not restore normal performance, or no corrective measures are given, troubleshooting is required by higher echelon. Note on the repair tag how the equipment performed and what corrective measures were taken.

Note: When the main power input circuit to the AN/FRT-53 is on (MAIN POWER lamp on the power distribution panel is lit) and the O-330B/FR OVEN lamps are cycling normally, proceed directly to step 10 to avoid turning off the oven heater in the O-330B/FR. If the MAIN POWER lamp and the OVEN lamps on the O-330B/FR are off, begin with st p 1.

b. Checklist.

	Step	Unit	Action	Normal indication	Corrective measures
P R E P A R A T O R Y	3	O-330B/FR	Rotate OUTPUT TUNING control for reading just below 26.800 mc on hf portion of tuning dial. Plug a microphone into MIKE jack.		
	4	Power distribution panel.	Set HFO, IFO, and BFO switches to their off positions.		
	5	Power distribution panel.	Set POWER switch to its off position.		
	6	Rf amplifier	Set BAND-MCS switch to 2-4.		
	7	All components	Plug a headset into PHONES jack.		
			Set MAIN POWER circuit breaker to off position.		
			Apply a 2,000-cps audio signal to channel 1 (terminals 13 and 15 on E501 (fig. 29). (Signal level is adjusted in step 19.)		
E Q U I P M E N T P E R F O R M A N C E	8	Power distribution panel.	Set ALDC control fully counterclockwise. Connect suitable antenna or dummy load to E203 (fig. 29).		
E Q P O P E R	8	Power distribution panel.	Set MAIN POWER circuit breaker to on position.	MAIN POWER lamp lights. Cabinet blower fans operate.	Check cable connections between primary power source and power distribution panel. Check seating of plug P623 in jack J614 on ac power strip in equipment rack.
E Q U I P M E N T P E R F O R M A N C E	9	O-330B/FR	Set POWER switch to ON.	MAIN POWER pilot lamp lights. After several hours OUTER OVEN pilot lamp blinks on for approximately 5 seconds and off for approximately 30 seconds.	Check O-330B/FR power connection to J612 on the ac power strip. Check OVENS fuse.
	10	O-330B/FR	Set HFO switch to ON. Turn METER switch to HFO. Turn XTAL switch to VMO. Set OUTPUT control to midposition.	After several hours, INNER OVEN pilot lamp blinks on for approximately 90 seconds and off for approximately 90 seconds. Meter indicates rf output level.	Check OVENS fuse.
	11	O-330B/FR	Turn BEAT switch to ON. Turn HFO switch to ON. Turn XTAL switch to VMO. Turn MASTER	Headset indicates zero beat at many intervals throughout frequency range.	Check tubes V101, V102, V202 through V207, V301, and V302. Check headset. Check tubes V103 and V104.

	Step	Unit	Action	Normal indication	Corrective measures
E Q U I P M E N T P E R F O R M A N C E	12	O-330B/FR	OSCILLATOR FREQUENCY dial through entire frequency range. Turn MASTER OSCILLATOR FREQUENCY dial to 2,000 KCS (000) CPS reading. Adjust CALIBRATE control for zero beat.	ZERO BEAT pilot lamp lights at all times except at many of the zero beat intervals. Headset, and possibly ZERO BEAT pilot lamp, indicates zero beat when proper calibration is reached.	
	13	O-330B/FR	Turn MASTER OSCILLATOR FREQUENCY dial to 2,500 KCS, then to 3,000 KCS, then to 3,500 KCS, and then to 4,000 KCS. Adjust CALIBRATE control at each frequency setting listed above, but <i>do not</i> make more than two complete revolutions of the CALIBRATE control from its position at 2,000 KCS to effect calibration at any dial frequency. Upon completion of this step, tune O-330B/FR to 3.45 mc (para 36c).	Headset, and possibly ZERO BEAT pilot lamp, indicates zero beat within the limits of adjustment of CALIBRATE control.	Calibrate the O-330B/FR (para 26).
	14	Sideband exciter	Turn POWER switch to ON.	Power lamp on sideband exciter power supply, illuminating lamp behind tuning dial, and the OVEN lamp on sideband exciter power supply light.	Check to see that terminating plugs on cables W101 and W401 are connected as shown in figure 29.
	15	Sideband exciter	Turn EXCITER switch on sideband exciter to on.	EXCITER lamp on sideband exciter lights.	Check V401 and V402 in sideband exciter power supply.
	16	Sideband exciter	Set METER SW switch to CAL. Adjust CAL control for zero reading on meter.	Meter can be zeroed.	Check tube V112.
	17	Sideband exciter	Turn CARRIER INSERT control to 10. Set METER SW switch to MF. Rotate MF TUNING control for maximum reading on front panel meter.	Maximum meter reading is obtained at approximately 3.45 mc.	Check cable connections between J104 on sideband exciter and J208 of O-330B/FR (fig. 29). Check tubes V105, V113, V114, V115, and V126.
	18	Sideband exciter	Set METER SW switch to RF. Increase frequency setting of OUTPUT TUNING control to first peak reading obtainable on meter. If necessary, readjust OUTPUT control for optimum meter reading.	Maximum meter reading is obtained at approximately 26.8 mc.	Check tubes V116 through V120. Replace crystal Y102.
	19	Sideband exciter	Set LSB switch to CH 1. Set METER SW switch to LSB and adjust LSB GAIN control for -20 dbm meter indication.	Front panel meter indicates -20 dbm.	Adjust audio input from TS-382A/U. Check tube V123B. Check connections between

	Step	Unit	Action	Normal indication	Corrective measures
E Q U I P M E N T P E R F O R M A N C E	20	Sideband exciter	Set LSB switch to OFF and USB switch to CH 1. Set METER SW switch to USB and adjust LSB GAIN control for -20 dbm meter indication.	Front panel meter indicates -20 dbm.	E101 on sideband exciter and J501 power distribution panel. Adjust audio input from TS-382A/U.
	21	Sideband exciter	Rotate CARRIER INSERT control to 0 and adjust USB GAIN control for maximum meter reading of 100. Set METER SW switch to RF and adjust OUTPUT control for desired level. <i>Note:</i> The rf level required depends on the type of operation and the amount of carrier insertion desired. Refer to tuning procedures in paragraph 37 through 41 for carrier insertion instruction.	Front panel meter indicates desired output level.	Check tube V122B. Check tubes V123A and V125. Check diode assembly CR116 (pluckout unit).
	22	Sideband exciter	Set USB switch to OFF and LSB switch to CH 1. Set METER SW switch to LSB and adjust LSB GAIN control for maximum meter reading of 100. Set METER SW switch to RF and adjust OUTPUT control for desired rf level.	Front panel meter indicates desired output level.	Check tubes V122A and V124. Check diode assembly CR115 (pluckout unit).
	23	Sideband exciter	Set METER SW switch to LSB; set LSB switch to MIKE and speak into microphone.	Front panel meter indicates audio level.	Check tube V101. Check microphone connection at MIKE jack.
	24	Sideband exciter	Set EXCITER switch to STANDBY.	EXCITER lamp goes out.	
	25	Sideband exciter	Speak into microphone and adjust VOX GAIN control until EXCITER lamp lights.	EXCITER lamp lights as long as microphone is spoken into.	Check tubes V110, V111, and V127.
	26	Sideband exciter	With microphone connected but with no direct speech input, increase room noise (such as turning up an associated loudspeaker).	EXCITER lamp lights as a result of the extraneous room noise.	Check setting of VOX GAIN control; increase if necessary.
	27	Sideband exciter	Apply an audio signal (similar to that in step 5) to squelch input of AN/FRT-53 (terminals 11 and 12 of E501 on power distribution panel). Turn up setting of SQUELCH GAIN control.	EXCITER lamp goes out.	
	28	Low voltage power supply	Set PA OVERLOAD circuit breakers (PLATE, SCRNGRID, and CONT GRID) to on position. Set MAIN POWER circuit breaker to on position.	MAIN POWER pilot lamp lights.	

	Step	Unit	Action	Normal indication	Corrective measures
E Q U I P M E N T P E R F O R M A N C E	29	Rf amplifier	Set MULTI METER switch to PA DC BIAS.	PA FIL PRI meter indicates 115 volts ac. Blower motor B201 in rf amplifier, and blower motor B401 in high voltage power supply go on. MULTI METER meter indicates -100 volts dc.	Set PA FIL PRI ADJUST switch to position that produces 115 volts ac on meter. Check to see that door interlock on high voltage power supply front panel is secure. If no reading is obtained, check to see that PA OVERLOAD CONT GRID circuit breaker on low voltage power supply is on. If trouble persists, check bias rectifier V701 on low voltage power supply.
	30	Low voltage power supply	Set TRANSMITTER VOLTAGES switch to ON.	TRANSMITTER VOLTAGES lamp lights after 3 minutes have elapsed from time MAIN POWER circuit breaker was placed in its on position.	Check tubes V704 through V708.
		Rf amplifier	Set MULTI METER switch to RF 1ST AMPL PLATE; then tune 1ST AMPL TUNING control (para 42d and e).	A peak reading is obtained at operating frequency.	Check rf amplifier V201.
	32	Rf amplifier	Set MULTI METER switch to RF PA GRID; then tune PA GRID TUNING control (para 42f).	A peak reading is obtained at operating frequency.	Check driver tube V202.
	33	Rf amplifier	Set PA TUNING and PA LOADING controls and PA LOADING switch to settings in tuning chart (supplied with equipment) which correspond to operating frequency.		
	34	Sideband exciter	Set OUTPUT control maximum counterclockwise.	With MULTI METER switch on rf amplifier set to any RF position, reading on MULTI METER drops to zero.	
	35	Low voltage power supply	Set MULTI METER switch on rf amplifier to RF PA PLATE; set FINAL VOLTAGES switch on low voltage power supply to ON.	FINAL VOLTAGES lamp lights. Reading appears on the rf amplifier MULTI METER meter.	Check to see that all cover interlocks are closed. Check to see that cables between J401 on high voltage power supply and P202 on rf amplifier, and between J702 on low voltage power supply and P401 on high voltage power supply are secure.
					Check rectifiers V401 and V402.
	36	Rf amplifier	Increase setting on OUTPUT control on sideband exciter.	PA PLATE CURRENT meter indicates 300 milliamperes.	Check power amplifier V203.

	Step	Unit	Action	Normal indication	Corrective measures
E Q U I P M E N T P E R F O R M A N C E	37	Rf amplifier	Tune PA TUNING control.	A pronounced dip is detected at operating frequency.	Check cable connections between J113 on sideband exciter and J704 on low voltage power supply.
	38	Rf amplifier	Adjust setting of PA LOADING control.	PA PLATE CURRENT meter indicates an increase in current.	
	39	Rf amplifier	Set MULTI METER switch to RF OUT.	MULTI METER indicates rf output of rf amplifier.	
	40	Rf amplifier	With MULTI METER switch set to RF OUT adjust OUTPUT control on sideband exciter for desired reading on rf amplifier MULTI METER. Set ALDC switch to EXT. Rotate ALDC control clockwise until MULTI-METER reading just begins to decrease. Attempt to increase rf output by rotating OUTPUT, CARRIER INSERT, or LSB GAIN control on sideband exciter (LSB switch must be in CH 1 position for LSB GAIN control to be effective).	MULTI METER reading does not go beyond preset level.	
S T O P	41	Low voltage power supply.	Set FINAL VOLTAGES switch to OFF.	FINAL VOLTAGES lamp goes out.	
	42	Low voltage power supply.	Set TRANSMITTER VOLTAGES switch to STANDBY. <i>Note: Wait 5 minutes before proceeding with remaining steps.</i>	PA PLATE CURRENT meter on rf amplifier reads zero. FINAL VOLTAGES lamp goes out. MULTI METER on rf amplifier reads zero (in any position of MULTI METER switch).	
	43	Low voltage power supply.	Set MAIN POWER circuit breaker to off position.	MAIN POWER lamp goes out. PA FIL PRI meter reads zero. Blower motor B201 in rf amplifier and blower motor B401 in high voltage power supply go off.	
	44	Sideband exciter	Set POWER switch to OFF.	Indicator lamp on sideband exciter power supply goes out. EXCITER lamp goes out. OVEN lamp stays out. Tuning dial illuminating lamp goes out.	
	45	O-330B/FR	Set HFO switch in off position. <i>Note: If AN/FRT-53 is to be turned on again within 48 hours, do not disturb remaining power controls. If AN/FRT-53 will be off for any extended period greater than 48 hours or if repairs of O-330B/FR are necessary, proceed with following steps.</i>	Meter reads zero.	

	Step	Unit	Action	Normal indication	Corrective measures
S T O P	46	Power distribution panel.	Set POWER switch to off position.	MAIN POWER lamp goes out. INNER OVEN and OUTER OVEN lamps stay out. MAIN POWER lamp goes out. Equipment rack blower fans go off.	
			Set the MAIN POWER circuit breaker to off position.		

54. Removal and Replacement of Components and Air Filters

The various components of the AN/FRT-53 are either slide mounted or panel mounted. Procedures for removing and replacing these components are given in a through c below. Refer to d below for air filter removal and replacement instructions.

a. Panel-Mounted Components.

- (1) On the front panel of the component, remove the screws that secure the component to the equipment rack.
- (2) Slide the component out of the equipment rack until the cable connections at the rear are accessible.
- (3) Tag and disconnect all cables and wires connected to the jacks and terminal boards of the component being replaced.
- (4) Remove the component.
- (5) Set the replacement component in position in the equipment rack.
- (6) Connect all cables and wires.
- (7) Push the component into the equipment rack; be sure the cables do not kink or bind.
- (8) Replace the screws that secure the component to the equipment rack.

b. Slide-Mounted Components (fig 8).

Warning: Two men should replace heavy components such as the O-330B/FR, and the power supplies.

- (1) Remove the screws that secure the component to the front of the equipment rack.
- (2) Pull the component out of the equipment rack until the release buttons on the chassis slides engage the holes in the tracks.
- (3) Tag and disconnect all cables and

wires connected to the rear of the component being replaced.

- (4) Press the release buttons and slide the component off the tracks.
- (5) Set the replacement component in position on the tracks.

Note: It may be necessary to hold the tracks in the extended position while positioning the component.

- (6) Slide the component on the tracks until the release buttons catch.
- (7) Press the release buttons and push the component into the equipment rack until the release buttons engage the holes in the tracks.
- (8) Make all cable and wire connections at the rear of the component.
- (9) Press the release buttons and push the component into the equipment rack; be sure the cables do not kink or bind.
- (10) Replace the screws that secure the component to the equipment rack.

c. *Tilting Slide-Mounted Components* (fig. 8). To tilt the component to reach the top or bottom of the chassis:

- (1) Remove the screws that secure the component to the equipment rack.
- (2) Pull the component out of the equipment rack until the release buttons engage the hole in the tracks.
- (3) Pull out the tilt lever and tilt the component to the desired position.
- (4) Pull out the tilt lever to return the component to the horizontal position.
- (5) Press the release buttons and slide the component into the equipment rack; be sure that the cables do not kink or bind.
- (6) secure the component to the equipment rack.

<p>ADDITIONAL ITEMS FOR 2D AND 3D ECHELON INSPECTIONS</p> <p>26. INSPECT ANTENNA FOR ECCENTRICITIES, CORROSION, LOOSE FIT, DAMAGED INSULATORS AND REFLECTORS.</p> <p>27. CHECK FOR NORMAL OPERATION. ✓</p> <p>28. BEFORE SHIPPING OR STORING, REMOVE BATTERIES</p> <p>IF DEFICIENCIES NOTED ARE NOT CORRECTED DURING THE INSPECTION, INDICATE ACTION TAKEN FOR CORRECTION.</p> <p style="font-size: 1.2em; text-align: center;"><i>ITEM 7. REPLACED CRACKED PLUS P202 ON RF AMPLIFIER CHASSIS.</i></p>	<p style="text-align: center;">MAINTENANCE CHECK LIST FOR SIGNAL EQUIPMENT SOUND EQUIPMENT, RADIO, DIRECTION FINDING RADAR, CARRIER, RADIOSONDE AND TELEVISION (AR 750-625)</p> <p>EQUIPMENT NOMENCLATURE <i>RADIO TRANSMITTING SET AN/FRT-53</i></p> <p>EQUIPMENT SERIAL NUMBER <i>000</i></p> <p style="text-align: center;">INSTRUCTIONS</p> <p>This form may be used for a period of one month by using the correct dates and weeks of the month. It is to be used as a Preventive Maintenance check list for Signal equipment in actual use, or for a check on equipment prior to issue.</p> <ol style="list-style-type: none"> 1. For detailed Preventive Maintenance instructions see: <ol style="list-style-type: none"> a. The Technical Manual (in TM 11 series) for the equipment. (See DA Pamphlet Number 310-4) b. The Supply Bulletin (SB 11-100 series) for the equipment. (See DA Pamphlet Number 310-4) c. The Department of the Army Lubrication Order. (See DA Pamphlet Number 310-4) 2. The following action will be taken by either the Communications Officer/Chief for 1st echelon, or the Inspector for higher echelon: <ol style="list-style-type: none"> a. Enter Equipment Nomenclature and Serial Number. b. Strike out items that do not apply to the equipment. 3. Operator/Inspector will enter in the columns entitled CONDITION, on the proper line, a notation regarding the condition, using symbols specified under LEGEND. 4. After operator completes each daily inspection he will initial over the appropriate dates under "Daily Condition for Month", then return form to his supervisor. <p style="text-align: center;">TYPE OF INSPECTION <i>PREVENTIVE MAINTENANCE</i></p> <table border="1" style="width:100%; border-collapse: collapse;"> <thead> <tr> <th style="width: 10%;">OPERATOR</th> <th style="width: 10%;">2/3 ECHELON</th> <th style="width: 10%;">DATE</th> <th style="width: 70%;">SIGNATURE</th> </tr> </thead> <tbody> <tr> <td style="text-align: center;">✓</td> <td></td> <td style="text-align: center;"><i>2 MAR 62</i></td> <td style="text-align: center;"><i>Redney Stephen</i></td> </tr> <tr> <td> </td> <td> </td> <td> </td> <td> </td> </tr> <tr> <td> </td> <td> </td> <td> </td> <td> </td> </tr> <tr> <td> </td> <td> </td> <td> </td> <td> </td> </tr> </tbody> </table>	OPERATOR	2/3 ECHELON	DATE	SIGNATURE	✓		<i>2 MAR 62</i>	<i>Redney Stephen</i>												
OPERATOR	2/3 ECHELON	DATE	SIGNATURE																		
✓		<i>2 MAR 62</i>	<i>Redney Stephen</i>																		

DA FORM 11-238
 MAY 57

REPLACES DA FORMS 11-238, 1 NOV 55; 11-239, 11-244, 11-246, 11-248, 11-249, 11-250, AND 11-251; WHICH ARE OBSOLETE.

TM 6620-472-12-9

Figure 18. DA Form 11-238, pages 2 and 3 (second echelon check).

LEGEND for marking conditions: Satisfactory, ✓. Adjustment, Repair or Replacement required, X. Defect corrected, ⊗.		DAILY CONDITION FOR MONTH OF MARCH 1962																		
		1	2	3	4	5	6	7	8	9	10	11	12	13	14	15	16			
NO.	DAILY ITEM	CONDITION EACH WEEK							2D ECH ECH	CONDITION										
		1ST	2D	3D	4TH	5TH	6TH	7TH												
1.	COMPLETENESS AND GENERAL CONDITION OF EQUIPMENT. (Transmitter, receiver, carrying cases, wire, cables, microphones, tubes, spare parts, technical manuals).																			
2.	CLEAN DIRT AND MOISTURE FROM ANTENNA, MICRO-PHONES, HEADSETS, KEYS, JACKS, PLUGS, COMPONENT PANELS.																			
3.	INSPECT CONTROLS FOR NORMAL OPERATION. TAP CONTROLS LIGHTLY FOR EVIDENCE OF CUT-OUT FROM LOOSE CONTACTS.																			
4.	CHECK FOR NORMAL OPERATION OF EQUIPMENT. BE ALERT FOR UNUSUAL OPERATION OR CONDITION.																			
	WEEKLY																			
5.	CLEAN AND TIGHTEN EXTERIORS OF CASES, RACKS, MOUNTS, TRANSMISSION LINES.																			✓
6.	INSPECT CASES, MOUNTS, ANTENNA TOWERS AND EXPOSED METAL SURFACES FOR RUST, CORROSION.																			✓
7.	INSPECT CORDS, CABLE, WIRE, SHOCK MOUNTS FOR CUTS, KINKS, BREAKS, FRAYING, UNDUCE STRAIN.																			⊗
8.	CHECK ANTENNA-COX WIRE FOR PROPER TENSION OR DAMAGE.																			
9.	INSPECT SHAWNS AND LEATHER BELTS FOR MILDew, TEAR, FRAYING.																			
10.	INSPECT ACCESSIBLE ITEMS FOR LOOSENESS: SWITCHES, KNOBS, JACKS, CONNECTORS, RELAYS, TRANSFORMERS, MOTORS, PILOT LIGHTS, BLOWERS, ETC.																			✓
11.	CLEAN AND/OR INSPECT AIR FILTERS, BRASS NAME PLATES, DIAL AND METER WINDOWS.																			✓
12.	INSPECT STORAGE BATTERIES FOR CORROSION, TERMINAL SPECIFIC GRAVITY, DAMAGED CELLS, INSPECT SOLY BATTERIES FOR LEAKAGE.																			✓
	ADDITIONAL ITEMS FOR 2D AND 3D ECHELON INSPECTIONS																			
13.	INSPECT SHELVES AND COVERS FOR ABSENCE OF WEATHER PROTECTING, TEAR, FELLING.																			
14.	CHECK TERMINAL BOX COVERS FOR CRACKS, SHIRT LEAK, DAMAGED GASKETS, GREASE.																			

ADDITIONAL ITEMS FOR 2D AND 3D ECHELON INSPECTIONS

18. INSPECT SEATING OF READILY ACCESSIBLE PLUCK-OUT ITEMS: TUBES, LAMPS, FUSES, CRYSTALS, CONNECTORS, VIBRATORS, PLUG-IN COILS.

19. INSPECT RELAYS AND CIRCUIT BREAKERS FOR LOOSE MOUNTINGS, BAD CONTACTS, MIS-ALIGNMENT OF CONTACTS AND SPRINGS, PROPER SPRING TENSION.

17. INSPECT VARIABLE CAPACITORS FOR DIRT, MIS-ALIGNMENT OF PLATES, LOOSE MOUNTINGS, MOISTURE.

18. INSPECT RESISTORS, BUSHINGS AND INSULATORS FOR CRACKS, CHIPPING, BLISTERING, MOISTURE, DISCOLORATION.

19. CLEAN AND TIGHTEN SWITCHES, TERMINAL BLOCKS, BLOWERS, RELAY CASES AND INTERIORS OF CHASSIS AND CABINETS NOT READILY ACCESSIBLE.

20. INSPECT TERMINAL BLOCKS FOR LOOSE CONNECTIONS, CRACKS AND BREAKS.

21. INSPECT TERMINALS OF LARGE FIXED CAPACITORS AND RESISTORS FOR DIRT, CORROSION, LOOSE CONTACTS.

22. INSPECT TRANSFORMERS, CHOKES, POTENTIOMETERS AND RHEOSTATS FOR OVERHEATING AND OIL LEAKAGE.

23. INSPECT GENERATORS, AMPLIFIERS, MOTORS FOR BRUSH WEAR, SERVICING TENSION, WORN AND FITTING OF COMMUTATOR.

24. INSPECT CATHODE RAY TUBES FOR BURNIN, SCREEN SEALS.

25. INSPECT WATERPROOF GASKETS FOR TEARS, WORN OR LOOSE PARTS.

CONTINUED ON PAGE 4

Figure 19. DA Form 11-238, pages 1 and 4 (second echelon check).

d. *Air Filters.*

- (1) *High voltage power supply air filter.* To remove the air filter from the high voltage power supply, open the door on the front of the component and slide the air filter up through the opening in the air filter frame. To replace the air filter in the high voltage power supply, insert the filter in the frame and then lock the door.
- (2) *Rf amplifier air filter.* To remove the air filter from the rf amplifier, remove the screw and air filter holding bracket from the top of the rear panel of the component and slide the air filter up through the opening in the air filter frame. To replace the air filter, insert the filter in the air filter frame and secure the air filter holding bracket in position with the screw.

55. Tube Removal and Replacement

Warning: Turn off all power before attempting tube replacement.

To reach the tubes in the various components of the AN/FRT-53, follow the directions in paragraph 54. Most of the tubes are easily replaceable. Certain tubes require special procedures for removal and replacement. These procedures are detailed in a through c below.

a. *Replacing Tube V203 in Rf Amplifier* (fig. 20).

- (1) Slide the rf amplifier chassis out of the equipment rack and remove the top cover plate.
- (2) Loosen the tube clamp screw on V203.
- (3) Swing the tube clamp over the top of the tube and remove the tube.
- (4) Seat the replacement tube in the tube socket and place the tube clamp over the tube.
- (5) Tighten the tube clamp screw.
- (6) Replace the top cover plate and and slide the rf amplifier back into the equipment rack.

b. *Replacing V401 or V402 in High Voltage Power Supply* (fig. 26).

Warning: Before proceeding, allow enough time for the tubes to cool.

- (1) Slide the high voltage power supply out of the equipment rack and remove the top cover plate.
- (2) Remove the Phillips screw that holds the bracket over the tubes and remove the bracket.
- (3) Remove the connection to the top plate cap of the tube being replaced and remove the tube.
- (4) Seat the replacement tube in the tube socket, and replace the connection to the top plate cap.
- (5) Replace the bracket over the tubes and secure it with the Phillips screw.
- (6) Replace the top cover plate and slide the high voltage power supply back into the equipment rack.

c. *Replacing V201 Through V207 in O-330B/FR* (fig. 22).

- (1) Slide the O-330B/FR out of the equipment rack and remove the top cover plate.
- (2) To reach the V200 series tubes, removal of the O-330B/FR power supply chassis is necessary. Disconnect the following plugs:
 - (a) Plug P301 from jack J101.
 - (b) Plug P101 from jack J201.
 - (c) Plug P102 from jack J203.
- (3) Loosen the four 1/4-turn fasteners (two on the front panel and two under the rear of the power supply chassis).
- (4) Remove the power supply chassis from the O-330B/FR by sliding the chassis to the rear.
- (5) Replace a defective tube with a known good tube. Be sure to replace the tube shield.
- (6) Replace the power supply chassis into the O-330B/FR by sliding the chassis to the front.
- (7) Tighten the four 1/4-turn fasteners.
- (8) Mate the plugs and jacks that were disconnected in (2) above.
- (9) Replace the top cover plate and slide the O-330B/FR back into the equipment rack.

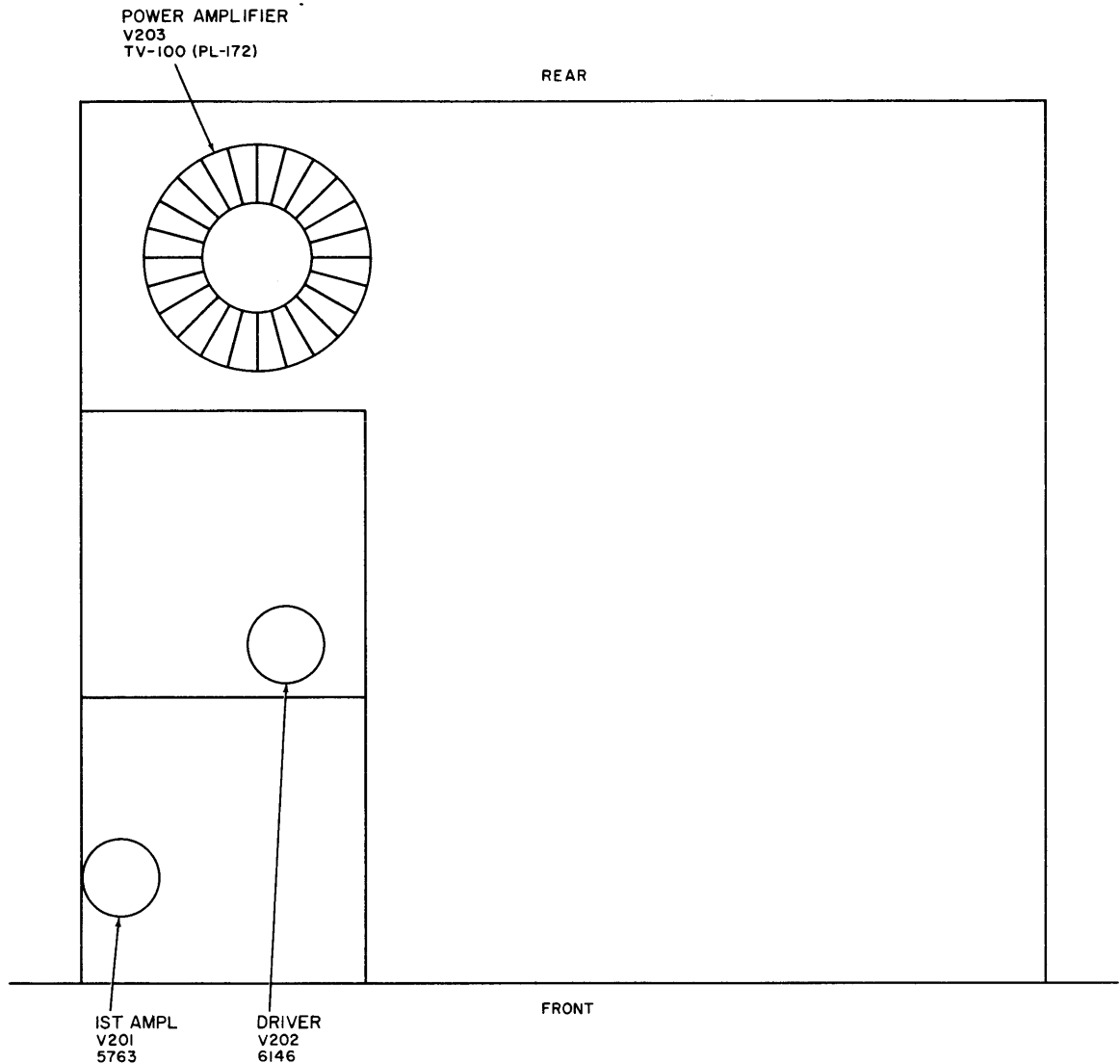

TM5820-472-12-10

Figure 20. Rf amplifier, tube location.

56. Replacement of Crystals

Crystals are contained in the sideband exciter and the O-330B/FR. Removal and replacement procedures for these crystals are contained in *a* and *b* below:

a. Sideband Exciter (fig. 27).

- (1) Slide the sideband exciter out of the equipment rack and remove the bottom cover plate.
- (2) Remove the six screws that hold the bottom cover plate of the oven and oscillator assemblies and remove the plate.
- (3) To remove the crystal (Y101

through Y108), pull up on the crystal holder.

- (4) Insert the replacement crystal firmly into the socket.
- (5) Replace the cover plate over the bottom of the oven and oscillator assemblies.
- (6) Replace the bottom cover plate on the sideband exciter and slide the component into the equipment rack.

b. O-330B/FR (fig. 21 and 22).

Note: Crystal Y301, in the variable master oscillator oven, is not replaced at this echelon.

- (1) To reach the Y200 series crystals,

the crystal-holding spring. Replace the power supply chassis (para 55c(6) through (9)).

57. Replacement of Sideband Exciter Tuning Dial Lamp

a. Remove the four screws from the sides of the front panel of the sideband exciter and slide the sideband exciter out of the equipment rack.

b. Loosen the four 1/4-turn fasteners at the rear of the sideband exciter and remove the top meshed cover plate (sliding it toward the rear of the chassis).

c. Press in on the tuning dial lamp and turn it counterclockwise to unlock.

d. Pull out the lamp and replace it with a new one.

e. Press the new lamp in and turn it clockwise to lock.

f. Slide the meshed cover plate back over the chassis and tighten the four 1/4-turn fasteners.

g. Slide the sideband exciter into the equipment rack and secure it with the four screws previously removed.

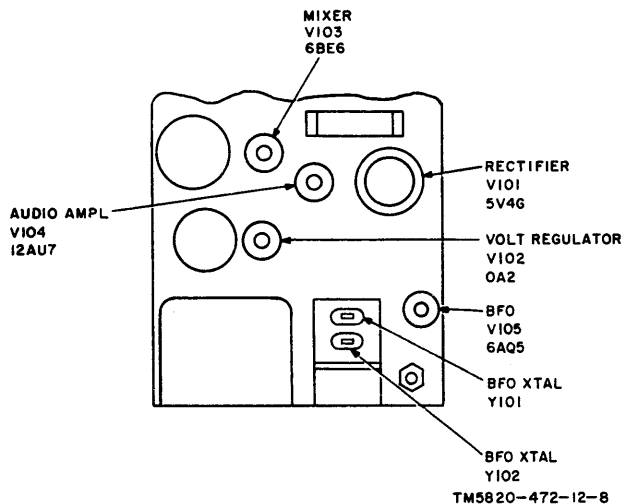

Figure 21. O-330B/FR, variable frequency oscillator, top view.

refer to the procedure for the V200 series tube access (para 55c).

- (2) Push aside the crystal-holding spring to remove the Y100 or Y200 series crystals.
- (3) Pull up the crystal holders to remove them from the socket.
- (4) Insert the replacement crystal firmly into the socket, and replace

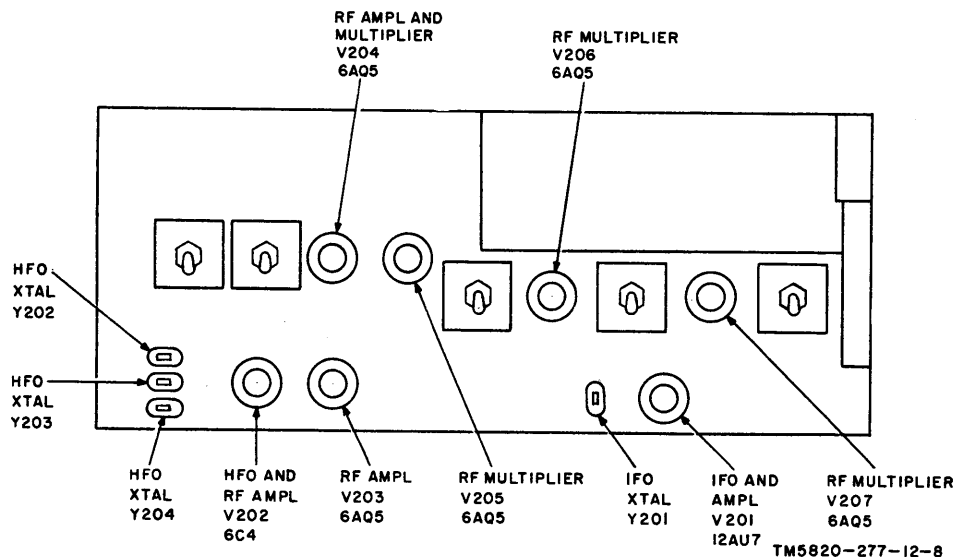
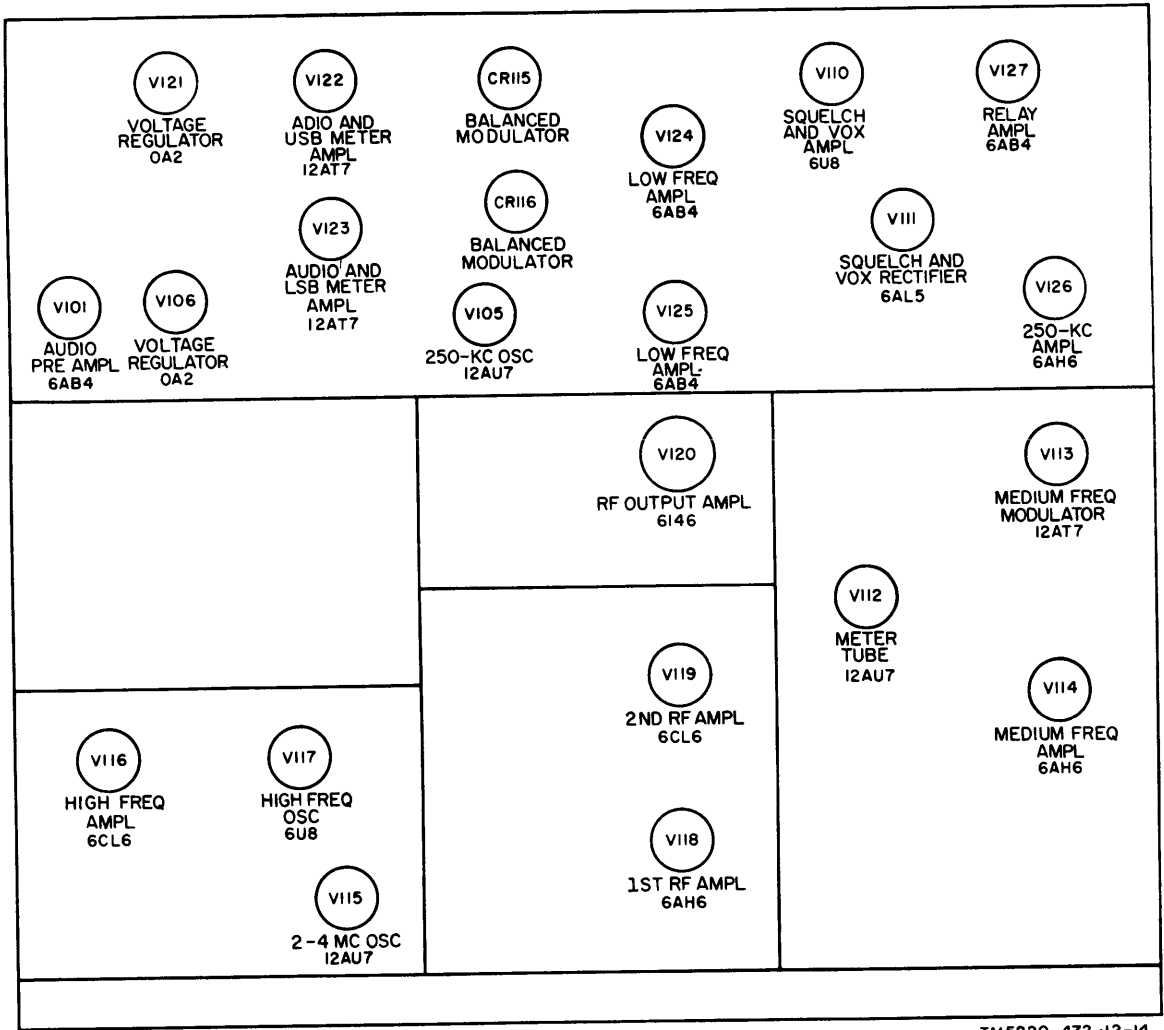

Figure 22. O-330B/FR, rf multiplier chassis, top view.



FRONT

TM5820-472-12-14

Figure 23. Sideband exciter, tube location.

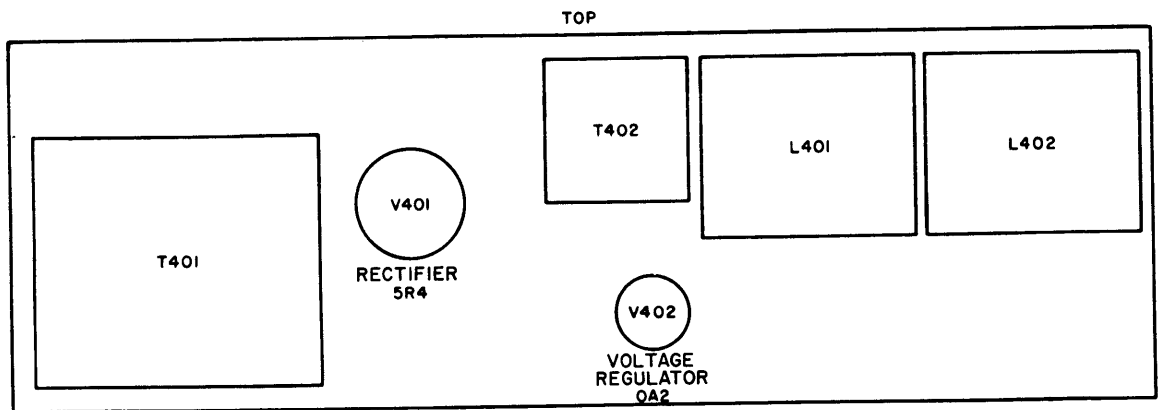

TM5820-472-12-15

Figure 24. Sideband exciter power supply, tube location.

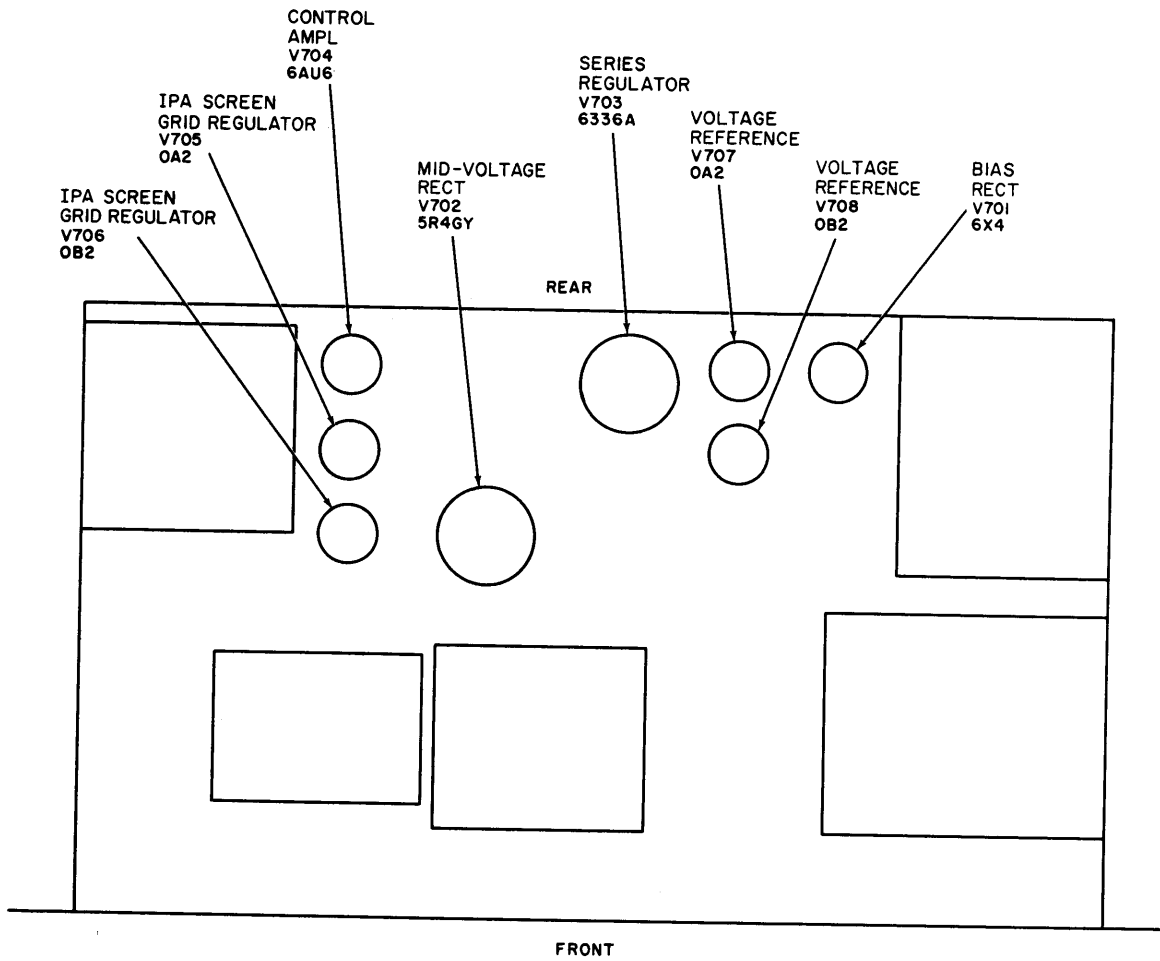

TM5820-472-12-16

Figure 25. Low voltage power supply, tube location.

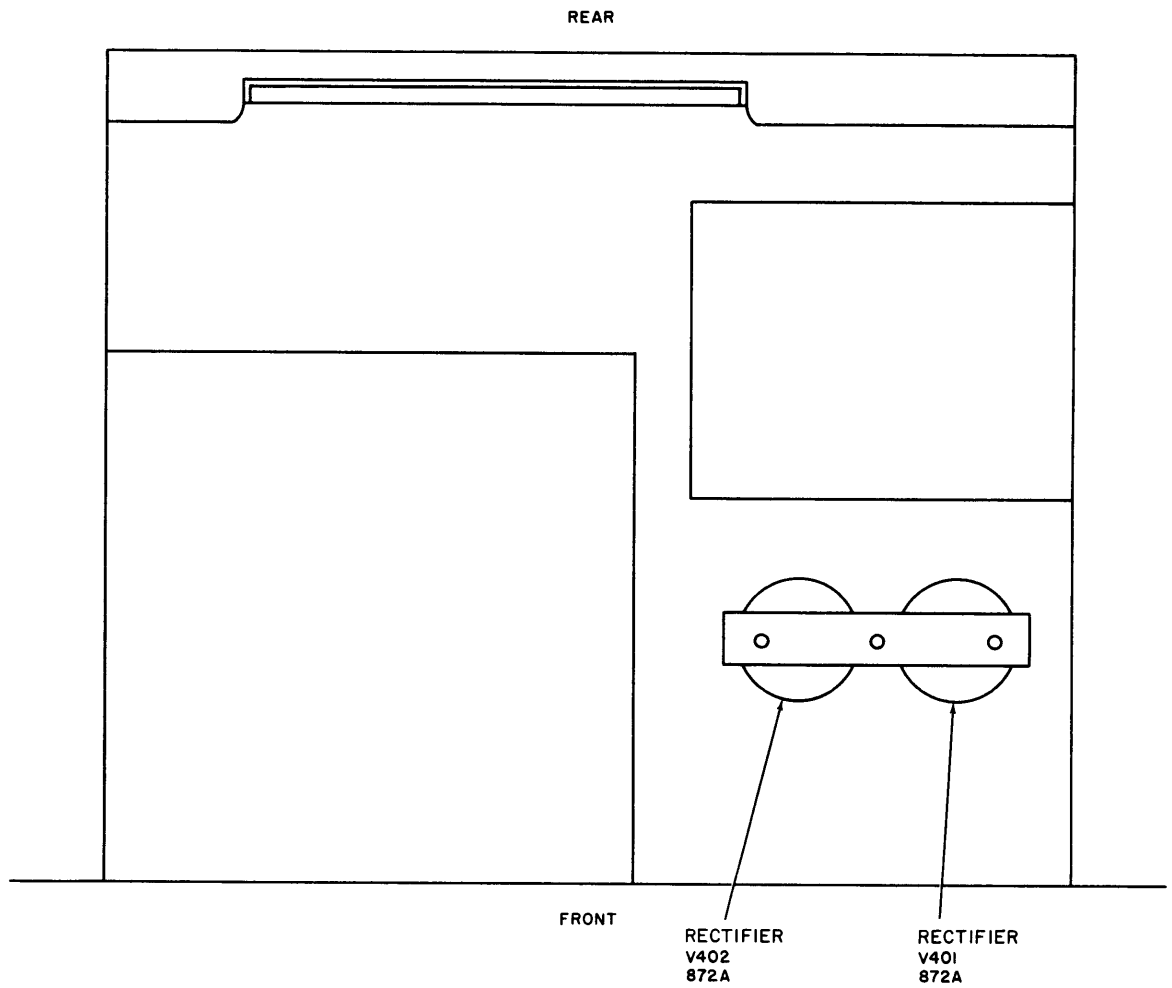

TM5820-472-12-17

Figure 26. High voltage power supply, tube location.

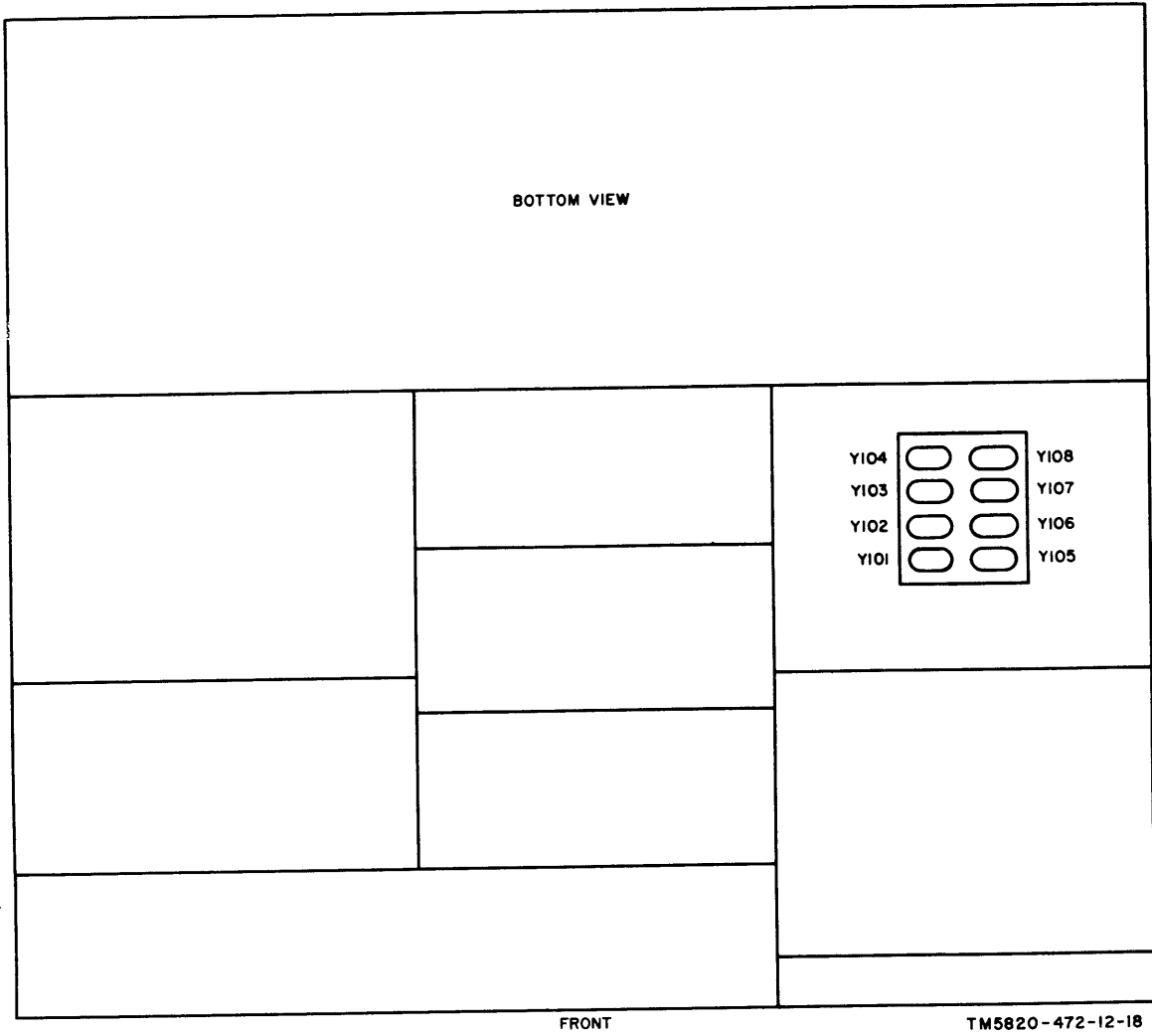

Figure 27. Sideband exciter, crystal location.

CHAPTER 5

BASIC THEORY

58. General

(fig. 28)

Radio Transmitting Set AN/FRT-53 consists of an rf amplifier and power supplies, a sideband exciter assembly, and a variable master oscillator (O-330B/FR). The initial carrier frequency, derived by the O-330B/FR, is applied to the sideband exciter. (Internal crystals, not supplied with this equipment, may be used to derive a fixed carrier frequency within the sideband exciter.) Modulating circuits with the sideband exciter balance out the carrier frequency and produce sideband energy within the 2- to 32-mc rf spectrum that is delivered to the rf amplifier for linear rf amplification. Primary power and audio input channels are routed through the power distribution panel.

59. Power Distribution Panel

(fig. 28)

The power distribution panel controls the application of ac primary power to the components of the AN/FRT-53. All inputs to the AN/FRT-53, except the push-to-talk microphone, are applied to the power distribution panel for routing to the individual components. The channel 1 and channel 2 voice frequency signals from the associated telephone or teletypewriter equipment are fed to the power distribution panel and routed directly to the sideband exciter.

60. Sideband Exciter Assembly

(fig. 28)

The sideband exciter assembly consists of the sideband exciter chassis and a power supply. The sideband exciter develops the sideband energy for application to

the rf amplifier. The multiplexed teletypewriter and audio inputs to the sideband exciter (or voice frequencies from a push-to-talk microphone) are passed through modulator and rf amplifier stages to develop a 2- to 32-mc output. The input frequency to one of the modulator stages within the sideband exciter is supplied by a variable master oscillator in the O-330B/FR. The rf amplifier stages within the sideband exciter provide an output level of 1-watt maximum to the rf amplifier. An automatic load and drive control voltage, fed back from the rf amplifier, controls the signal level delivered to the input of the rf amplifier chassis. Operating potentials for the sideband exciter are obtained from the sideband exciter power supply which obtains its primary power through the power distribution panel.

61. Rf Amplifier and Power Supply

Assembly

(fig. 28)

The rf amplifier and power supply assembly consists of a linear rf power amplifier and two power supplies. The 2- to 32-mc rf output of the sideband exciter is fed to the rf amplifier. The rf amplifier consists of three rf amplifier stages which produce an output of 1-kw peak envelope power (pep). The two power supplies provide all the operating potentials for the rf stages. Voltage peaks in the AN/FRT-53 output are limited by the aldc signal developed in the rf amplifier. This signal may be used to limit the gain of various stages in the rf amplifier, or it may be routed through the low voltage power supply to limit the signal level at the output of the sideband exciter. The rf output stage supplies a 2- to 32-mc signal that is applied to an antenna system.

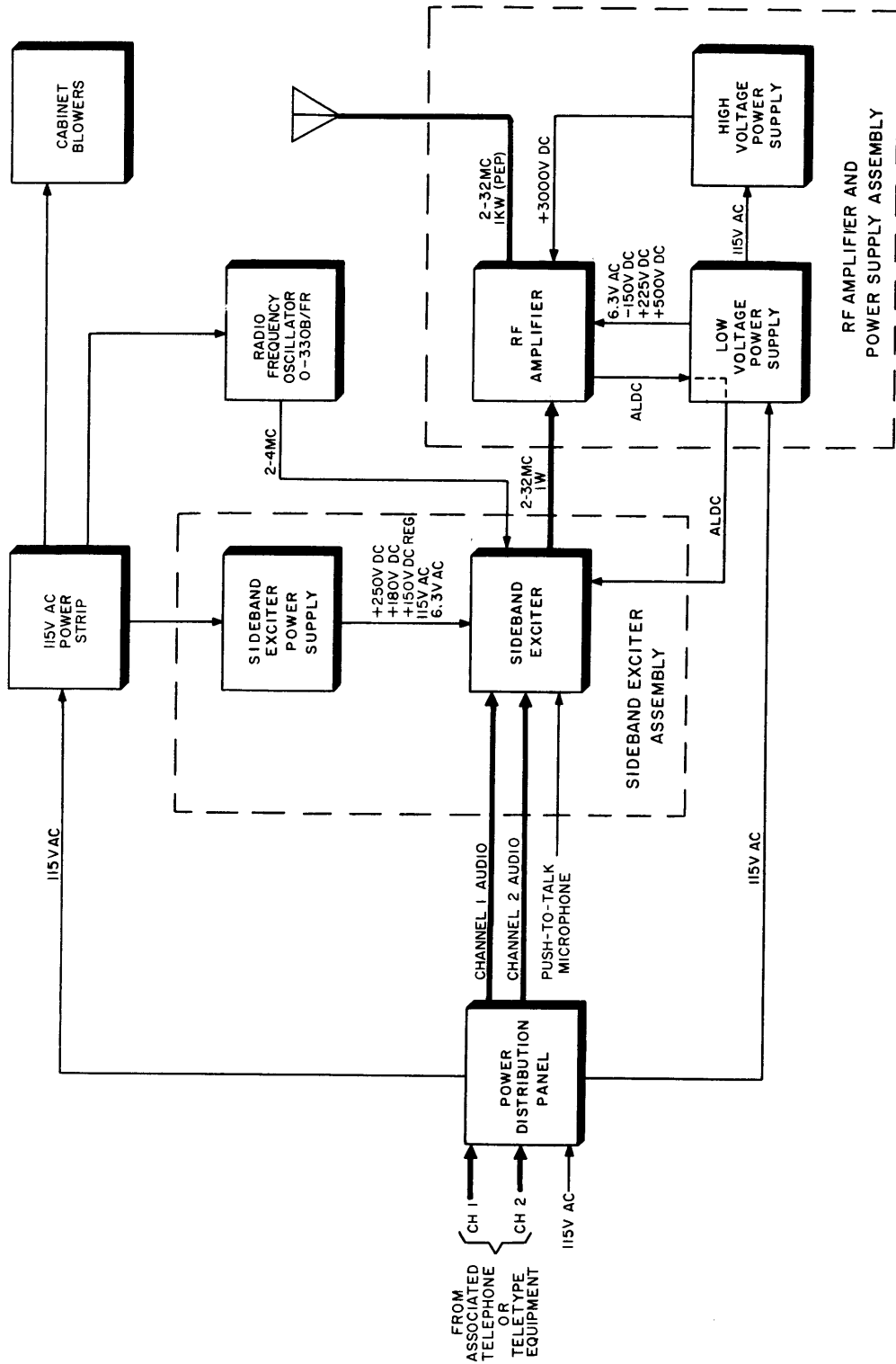

TM5820-472-12-9

Figure 28. AN/FRT-53, block diagram.

CHAPTER 6

SHIPMENT AND LIMITED STORAGE AND DEMOLITION TO PREVENT ENEMY USE

Section I. SHIPMENT AND LIMITED STORAGE

62. Disassembly of Equipment

The AN/FRT-53 is normally shipped with all components (except the power distribution panel) removed from the equipment rack. Use the procedures detailed below to disassemble the equipment.

Warning: Be sure that all power is turned off.

a. Removing Interunit Connections.

- (1) Remove the power input connections on the rear panel of the power distribution panel.
- (2) Remove all connections between external equipment and terminal strips at the rear of the power distribution panel.
- (3) Disconnect the antenna from J202 at the rear of the rf amplifier chassis.
- (4) Refer to figure 29 and remove all interunit cables.

b. Component Removal. Follow the instructions in paragraph 54 to remove all the panel-mounted and slide-mounted components. Coil all loose cables and place them on top of the components associated with the cables.

63. Repacking Equipment for Shipment or Limited Storage

a. Material Requirements. The exact procedure for repacking depends on the material available and the conditions under which the equipment is to be stored or shipped. Use the procedures outlined below whenever circumstances permit. A separate box is required for each component. The following list gives the packing personnel an indication of the materials necessary. For stock numbers of materials, refer to SB 38-100.

Material	Quantity
Wooden box (O-330B/FR)	16 x 22 x 25 in.
Wooden box (rf amplifier)	15 x 24 x 25 in.
Wooden box (low voltage power supply).	17 x 18 x 25 in.
Wooden box (high voltage power supply).	22 x 23 x 25 in.
Wooden box (sideband exciter)	15 x 21 x 25 in.
Wooden box (sideband exciter power supply).	11 x 21 x 25 in.
Waterproof-vaporproof barrier material.	210 sq ft.
Waterproof tape	100 ft.
Corrugated cardboard	180 sq ft.
Adhesive tape	80 ft.
Filler material	50 lb.
Flat steel strapping	225 ft.
Desiccant bags (each component) . .	4.
Humidity indicators (each component).	2.
Cushioning material (each component).	2 cu ft.
Steel strap locks	24.

b. Equipment Rack. When the equipment rack is to be shipped a short distance or stored for a short time, it may be moved without crating. However, if it is necessary to package the equipment rack, a crate should be constructed. Obtain a wooden skid (27 by 28 inches) and set a sheet of waterproof-vaporproof barrier material, a sheet of corrugated paper, and another sheet of moisture-vaporproof barrier material on top of the skid. The sheets should be approximately 26 by 27 inches. Set the equipment rack on top of the skid and cover the rack with moisture-vaporproof barrier material and corrugated cardboard. Use waterproof tape to secure all edges. Construct a crate over the equipment rack; use three steel bands to secure the crate. Set wooden blocks within the crate to position the equipment rack securely. The quantities of materials listed in a above does not include the material needed to crate the equipment rack.

The overall dimensions of the equipment rack are 66-3/4 by 20-5/8 by 21-1/2 inches.

c. Packaging.

- (1) Cushion each component on all surfaces with pads of filler material. Place the cushioned equipment within a wrap of corrugated cardboard. Secure the wrap with adhesive tape.
- (2) Tie the coiled cables in three places. Wrap the spare parts in corrugated cardboard and secure with adhesive tape.
- (3) Line the inside of each wooden box

with waterproof-vaporproof barrier material.

- (4) Place the packaged components inside the lined boxes. Also place the technical manuals and the spare parts within the lined wooden boxes. Fill excess space in the boxes with pads of corrugated cardboard and filler material. Secure the waterproof-vaporproof barrier material with waterproof tape.
- (5) Nail the covers on the boxes and apply three bands of metal strapping around each box.

Section II. DEMOLITION OF MATERIEL TO PREVENT ENEMY USE

64. Authority for Demolition

The demolition procedures given in paragraph 66 will be used to prevent the enemy from using or salvaging this equipment. Demolition of the equipment will be accomplished only upon the order of the commander.

65. Destruction Plan

If a destruction plan is not provided by higher authority, one should be prepared by the organization using the equipment. In this plan, personnel should be assigned specific destruction tasks, but all personnel in the using organization should be familiar with all aspects of the complete destruction plan. The plan must be adequate and easily carried out in the field and must provide for as complete a destruction as available time, equipment, and personnel will permit. Because the time required for complete destruction may not always be available, the destruction plan must establish priorities so that essential parts of the equipment will be destroyed in the order of their importance. Systematic destruction of the same important units of equipment of a given type will prevent the enemy from learning the important features of the equipment or assembling a complete equipment by cannibalization of partially destroyed equip-

ments. Adequate destruction of some units of the equipment should always be accomplished in preference to partial destruction of all units. Which of the methods of destruction listed in paragraph 66 is to be used depends on the time available for destruction.

66. Methods of Destruction

The following information is for guidance only. Some of the procedures outlined require the use of explosives and incendiary grenades which normally may not be authorized items for the AN/FRT-53. The issue of these and related materiel, and the conditions under which destruction will be effected, are command decisions in each case, according to the tactical situation.

<i>Method</i>	<i>Requirements</i>
Mechanical ...	Axe, pick, mattock, sledge, crowbar, or similar implement.
Burning	Gasoline, oil, incendiary grenades, or other flammables.
Demolition	Suitable explosives or ammunition.

Prior to performing destruction by any of the following methods, mechanically smash all front panel meters and indicators.

a. Demolition. Plan for simultaneous detonation, and prepare charges of explosive, TNT (using 1-pound blocks or

equivalent) together with the necessary detonating cord to make up each charge, as indicated below:

<i>Charge</i>	<i>Location of charge</i>
1 pound	Open cover of rf amplifier and place the charge next to the tuning mechanism.
1 pound	Place charge on right side of O-330E/FR (above the variable master oscillator oven).
1 pound	Place 1-pound charges within each of the remaining components.

Connect these charges for simultaneous detonation with detonating cord. Provide for dual priming to minimize the possibility of a misfire. For priming, either a nonelectric blasting cap crimped to at least 5 feet of safety fuse (safety fuse burns at the rate of 1 foot in 30 to 45 seconds; test before using), or an electric blasting cap and firing wire may be used. Safety fuse, which contains black powder, and nonelectric blasting caps must be protected from moisture at all times. The safety fuse is ignited by a fuselight or match before personnel take cover. The electric blasting cap requires a blasting machine or equivalent source of electricity and is fired after personnel takes cover.

Warning: Keep the blasting caps, detonating cord, and safety fuse separated from the charges until required for use.

Notes:

1. For the successful execution of methods of destruction involving the use of demolition materials, all personnel concerned will become thoroughly familiar with the pertinent provisions of FM 5-25. Training and careful planning are essential. The danger area is approximately 300 yards.

2. If time and means are not available to carry out the above demolition procedure, place a hand grenade in the equipment rack through the access door on the front of the high voltage power supply chassis. Smash items not demolished by the grenade, as time permits.

b. Burning. See that instruction manuals and the equipment tuning charts are burned, regardless of other methods of destruction used for other components of the equipment.

- (1) Pile burnable materials, such as wood, rags, and sections of the cable system, on and under the materiel.
- (2) Pour gasoline and oil in and over all components of the AN/FRT-53. From a safe distance, ignite the materiel by means of incendiary grenade, flamethrower, or other suitable means.

Warning: When igniting the gasoline, consideration should be given to the highly flammable nature of gasoline and its vapors. Carelessness in its use may result in painful burns.

c. Disposal. Burn or scatter the destroyed parts in slit trenches, foxholes, or other holes, or throw them into streams.

APPENDIX I

REFERENCES

Following is a list of applicable references available to the operator and second echelon repairman of Radio Transmitting Set AN/FRT-53:

- | | |
|-------------------|---|
| DA Pam 310-4 | Index of Technical Manuals, Technical Bulletins, Supply Bulletins, Lubrication Orders, and Modification Work Orders. |
| FM 5-25 | Explosives and Demolition. |
| SB 38-100 | Preservation, Packaging, and Packing Materials, Supplies, and Equipment Used By the Army. |
| TB SIG 225 | Radioactive Electron Tube Handling. |
| TM 11-5820-277-12 | Operator's and Organizational Maintenance Manual: Oscillators, Radio Frequency O-330A/FR and O-330B/FR. |
| TM 6625-200-12 | Operation and Organizational Maintenance: Multimeter, Meter ME-26B/U. |
| TM 11-6625-261-12 | Operator's and Organizational Maintenance Manual: Audio Oscillator TS-382A/U, TS-382B/U, TS-382D/U, TS-382E/U, and TS-382F/U. |
| TM 11-6625-274-12 | Operator's and Organizational Maintenance Manual: Test Sets, Electron Tube TV-7/U, TV-7A/U, TV-7B/U, and TV-7D/U. |

APPENDIX II

MAINTENANCE ALLOCATION

Section I. INTRODUCTION

1. General

a. This appendix assigns maintenance functions to be performed on the major components by the lowest appropriate maintenance echelon.

b. Columns in the maintenance allocation chart are as follows:

- (1) *Part or component.* This column shows only the nomenclature or standard item name. Additional descriptive data are included only where clarification is necessary to identify the component.
- (2) *Maintenance function.* This column indicates the various maintenance functions allocated to the echelons.
 - (a) *Adjust.* To regulate periodically to prevent malfunction.
 - (b) *Inspect.* To verify serviceability and to detect incipient electrical or mechanical failure, by scrutiny.
 - (c) *Replace.* To substitute serviceable components, assemblies, or subassemblies, for unserviceable components, assemblies, or subassemblies.
 - (d) *Repair.* To restore an item to serviceable condition through correction of a specific failure or unserviceable condition. This function includes, but is not limited to, welding, grinding, riveting, straightening, and replacement of parts other than the trial and error replacement of running spare type items such as fuses, lamps, or electron tubes.
 - (e) *Align.* To adjust two or more components of an electrical system so that their functions are properly synchronized.

(f) *Rebuild.* To restore an item to a standard as near as possible to original or new condition in appearance, performance, and life expectancy. This is accomplished through the maintenance technique of complete disassembly of the item, inspection of all parts or components, repair or replacement of worn or unserviceable elements using original manufacturing tolerances and/or specifications and subsequent re-assembly of the item.

(3) *1st, 2d, 3d, 4th, 5th echelon.* The symbol X indicates the echelon responsible for performing that particular maintenance operation, but does not necessarily indicate that repair parts will be stocked at that level. Echelons higher than the echelon marked by X are authorized to perform the indicated operation.

(4) *Tools required.* This column indicates codes assigned to each individual tool equipment, test equipment, and maintenance equipment referenced. The grouping of the codes in this column of the maintenance allocation chart indicates the tool, test, and maintenance equipment required to perform the maintenance function.

(5) *Remarks.* Entries in this column will be utilized when necessary to clarify and of the data cited in the preceding columns.

c. Columns in the section allocation of tools for maintenance functions are as follows:

- (1) *Tools required for maintenance functions.* This column lists tool, test, and maintenance equipment

required to perform the maintenance functions.

- (2) *1st, 2d, 3d, 4th, 5th echelon.* The dagger (†) symbol indicates the echelons normally allocated the facility.
- (3) *Tool code.* This column lists the tool code assigned.

2. Maintenance by Using Organizations

When this equipment is used by signal service organizations organic to theater headquarters or communication zones to provide theater communications, those maintenance functions allocated up to and including fourth echelon are authorized to the organization operating this equipment.

Section II. MAINTENANCE ALLOCATION CHART

(1) Part or component	(2) Maintenance function	(3) 1st ech	(4) 2nd ech	(5) 3d ech	(6) 4th ech	(7) 5th ech	(8) Tools required	(9) Remarks
Radio Transmitting Set SBT-1KJ (AN/FRT-53)	adjust		x				none	
	inspect		x				none	
	replace		x				none	
	repair		x	x			2,3,7,8,9,10,11,12,13,15,16	
Cable assembly group	align				x		1,2,4,5,6,7,8,9,10,12,15,16,17,18	
	rebuild					x	1,2,4,5,6,7,8,9,10,12,14,16,17,18	
Exciter signal sideband SBE-3	replace		x					
	replace		x				2,3,7,8,9,10,11,12,13,15,16	
Oscillator, radio frequency AO-101	repair			x		x	1,2,4,5,6,7,8,9,10,12,14,16,17,18	
	rebuild							
Pow r supply A1397	replace		x				2,3,7,8,9,10,11,12,13,15,16	
	repair		x	x			1,2,4,5,6,7,8,9,10,12,14,16,17,18	
Oscillator Radio Frequency O-330B/FR	rebuild		x					
	replace		x	x		x	2,3,7,8,9,10,11,12,13,15,16	Separate MAC
Power panel APP-4	repair		x					
	rebuild			x			2,3,7,8,9,10,11,12,13,15,16	
Power supply, high voltage PAL-1KA	replace		x				1,2,4,5,6,7,8,9,10,12,14,16,17,18	
	repair			x				
Amplifier radio frequency RFD-1A	rebuild		x				2,3,7,8,9,10,11,12,13,15,16	
	replace			x		x	1,2,4,5,6,7,8,9,10,12,14,16,17,18	
Power supply PS-4A	replace		x				2,3,7,8,9,10,11,12,13,15,16	
	repair			x			1,2,4,5,6,7,8,9,10,12,14,16,17,18	
Power supply PS-5	rebuild		x				2,3,7,8,9,10,11,12,13,15,16	
	replace			x		x	1,2,4,5,6,7,8,9,10,12,14,16,17,18	
Rack assembly RAK-10A	replace		x				2,3,7,8,9,10,11,12,13,15,16	
	repair			x			1,2,4,5,6,7,8,9,10,12,14,16,17,18	
	rebuild			x			2,3,7,8,9,10,11,12,13,15,16	
	replace		x			x	1,2,4,5,6,7,8,9,10,12,14,16,17,18	

Section III. ALLOCATION OF TOOLS FOR MAINTENANCE FUNCTIONS

(1)	(2)	(3)	(4)	(5)	(6)	(7)	(8)
Tools required for maintenance functions	1st ech	2d ech	3d ech	4th ech	5th ech	Tool code *	Remarks
Analyzer, Spectrum TS-723/U	1	
Audio Oscillator TS-382/U	2	
Frequency Meter AN/URM-32	3	
Frequency Meter AN/URM-79	4	
Frequency Meter AN/URM-80	5	
Frequency Meter AN/USM-26	6	
*Headset HS-33A	7	
Multimeter TS-352/U	8	
Multimeter, Meter ME-26/U	9	
Oscilloscope OS-8/U	10	
Power Supply PP-1243/U	11	
Rf Signal Generator AN/URM-25	12	
Test Set AN/GRM-33	13	
Test Set, Electron Tube TV-2/U	14	
Test Set, Electron Tube TV-7/U	15	
Tool Kit TK-87/U	16	
Tool Kit TK-88/U	17	
Voltmeter, Meter ME-30/U	18	

*To be provided as shop support.

INDEX

	Paragraph	Page		Paragraph	Page
Additional equipment required -----	14	9	High voltage power supply, description--	13	9
Air filter, removal and replacement ----	54d	52	Housing requirements -----	17	13
Amplitude modulation, tuning procedure -----	40	36	Indicators and fuses, sideband exciter power supply -----	30	25
AN/FRT-53, description -----	7	6	Initial calibration, O-330B/FR -----	26	21
Calibration, O-330B/FR -----	26	21	Installation: -----		
Checking cable connections -----	24	20	Components -----	22	15
Checking unpacked equipment -----	18	13	Equipment rack -----	22	15
Checklist: -----			Wiring diagram, fig. 29 -----	71	
Equipment performance -----	53	43	Isb, tuning procedure -----	39	35
Operators -----	47	39	Low voltage power supply: -----		
Common names -----	4	3	Controls and indicators -----	31	27
Components: -----			Description -----	11	8
Installation: -----			Maintenance: -----		
Intercomponent connection diagram, fig. 29 -----	71		First echelon -----	44-48	39-42
Procedure -----	22	15	Second echelon -----	49-57	42-54
Removal and replacement -----	54	49	Test equipment, tools, materials ---	50	42
Table -----	6	5	Materials, maintenance -----	50	42
Connections: -----			Operator's: -----		
Checking cables -----	24	20	Checklist -----	47	39
External equipment -----	23	17	Maintenance, scope -----	44	39
Controls and Indicators: -----			Preventive maintenance -----	45	39
Low voltage power supply -----	31	27	Repairs -----	48	42
O-330B/FR -----	28	22	Visual inspection -----	46	39
Power distribution panel -----	32	27	Oscillator, Radio Frequency O-330B/FR, description -----	9	8
Rf amplifier -----	27	22	O-330B/FR: -----		
Sideband exciter -----	29	24	Calibration -----	26	21
Controls, preliminary settings -----	34c	31	Controls and indicators -----	28	22
Conversion, power, 115 to 230 volts ----	21	15	Description -----	9	8
Crystals: -----			Power distribution panel: -----		
Mf crystal, frequency determination	34b	30	Controls and indicators -----	32	27
Preoperational check -----	25	20	Description -----	12	8
Replacement -----	56	53	Theory -----	59	59
Cw, tuning procedure -----	41	36	Preliminary: -----		
Description: -----			Control settings -----	34c	31
AN/FRT-53 -----	7	6	Starting procedure -----	34	28
Equipment rack -----	7	6	Preoperational check -----	25	20
High voltage power supply -----	13	9	Preventive maintenance: -----		
Low voltage power supply -----	11	8	Operator -----	45	39
O-330B/FR -----	9	8	Second echelon -----	51	42
Power distribution panel -----	12	8	Purpose and use -----	3	3
Rf amplifier -----	8	6	Removal and replacement: -----		
Sideband exciter assembly -----	10	8	Air filters -----	54d	52
Destruction: -----			Components -----	54	49
Authority -----	64	62	Tubes -----	55	52
Methods -----	66	62	Repacking equipment -----	63	61
Plan -----	65	62	Repairs -----	48	42
Determination: -----			Replacement: -----		
Medium frequency crystal frequency	34b	30	Crystals -----	56	53
Vmo frequency -----	34a	28	Dial lamp -----	57	54
Dial lamp replacement -----	57	54	Rewiring for 115 volts or 230 volts --	21	15
Disassembly -----	62	61	Rf amplifier: -----		
Equipment: -----			Controls and indicators -----	27	22
Disassembly -----	62	61	Description -----	7	6
Performance checklist -----	53	43	Theory -----	61	59
Rack: -----			Tuning procedure -----	42	36
Description -----	7	6	Scope: -----		
Installation -----	20	14	Operators maintenance -----	44	39
Repacking -----	63	61	Second echelon maintenance -----	49	42
External equipment connections -----	23	17	Second echelon: -----		
Filters, removal and replacement -----	54d	52	Preventive maintenance -----	51	42
Forms and records -----	2	3	Visual inspection -----	52	43
Fuses, preoperational check -----	25	20			

	Paragraph	Page		Paragraph	Page
Sideband exciter:			Tilting panel-mounted components -----	54c	49
Controls and indicators -----	29	24	Tools, maintenance -----	50	42
Power supply, indicator and fuses---	30	25	Tubes:		
Tuning procedure -----	36	32	Preoperational check -----	25	20
Sideband exciter assembly:			Removal and replacement -----	55	52
Description -----	10	8	Tuning dial lamp replacement -----	57	54
Theory -----	60	59	Tuning procedure:		
Siting -----	16	13	Amplitude modulation -----	40	36
Ssb, tuning procedure -----	37	33	Cw -----	41	36
Starting procedure:			Isb -----	39	35
General -----	35	31	Rf amplifier -----	42	36
Preliminary -----	34	28	Sideband exciter -----	36	32
System application -----	15	9	Ssb -----	37	33
Table of components -----	6	5	Types of operation -----	33	28
Technical characteristics -----	5	4			
Test equipment, maintenance -----	50	42	Uncrating and unpacking -----	19	13
Theory:			Visual inspection:		
Power distribution panel -----	59	59	Operators -----	46	39
Rf amplifier and power supply group	61	59	Second echelon -----	52	43
Sideband exciter assembly -----	60	59			

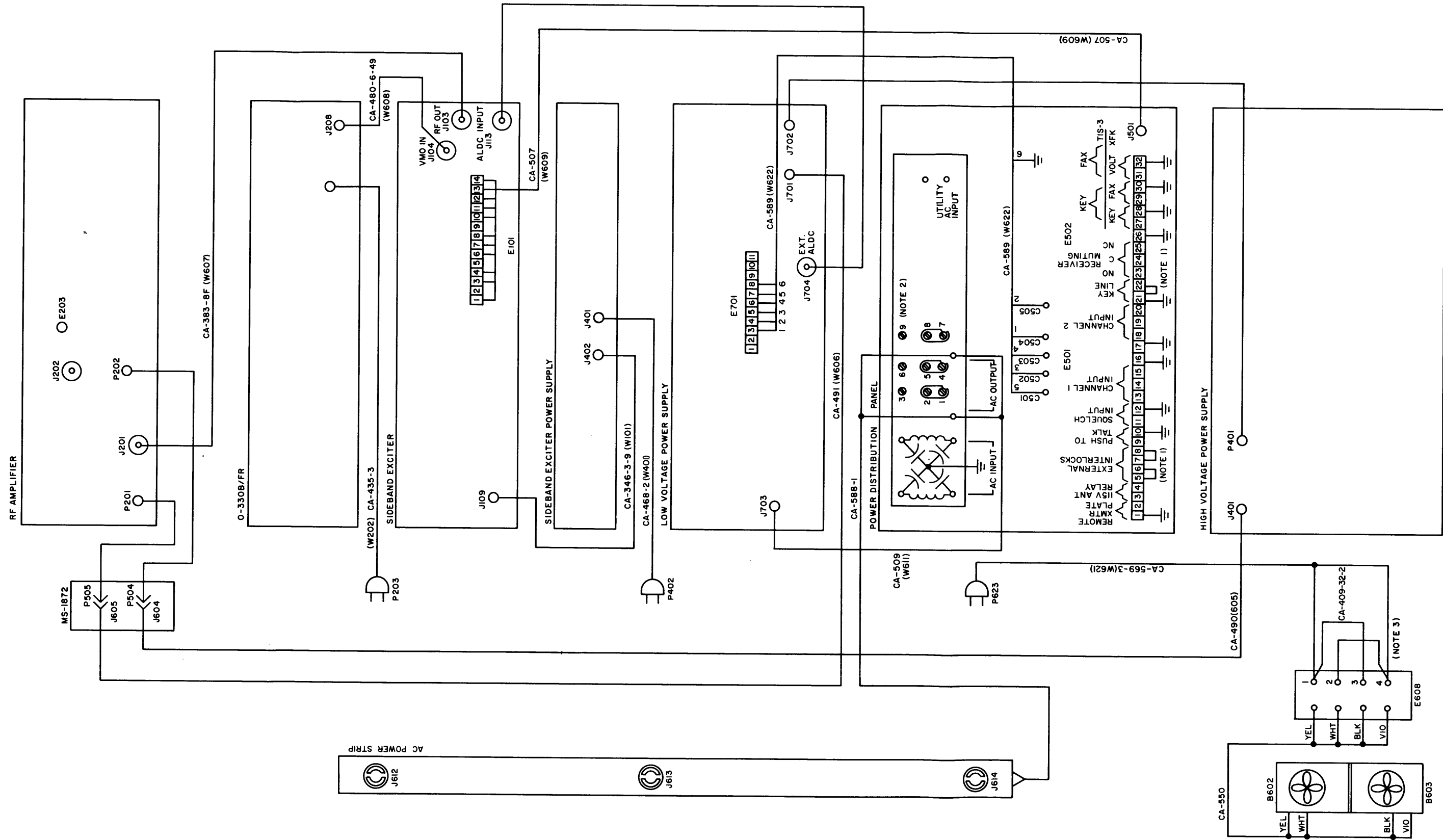

- NOTES:
1. WHEN NOT USING EXTERNAL INTERLOCKS OR KEYING, CONNECT JUMPERS BETWEEN TERMINALS 5 AND 6, 7 AND 8, 21 AND 22 AS SHOWN.
 2. FOR 115V OPERATION, CONNECT: 1 AND 2, 4 AND 5, 7 AND 8 FOR 230V OPERATION, CONNECT: 2 AND 3, 5 AND 6, 8 AND 9.
 3. FOR 230V OPERATION REMOVE JUMPERS BETWEEN TERMINALS 1-3 AND 2-4. ADD A JUMPER BETWEEN TERMINALS 2 AND 3.

Figure 29. Intercomponent cabling and connection diagram.

By Order of Secretary of the Army:

G. H. DECKER,
General, United States Army,
Chief of Staff.

Official:

J. C. LAMBERT,
Major General, United States Army,
The Adjutant General.

Distribution:

Active Army:

DASA (6)	WtAMC (1)
USASA (2)	USA Trans Tml Comd (1)
CNGB (1)	Army Tml (1)
Tech Stf, DA (1) except	POE (1)
CSigO (18)	OSA (1)
Tech Stf Bd (1)	USAEPG (2)
USCONARC (5)	AFIP (1)
USAARTYBD (1)	AMS (1)
USAARMBD (2)	Army Pictorial Cen (2)
USAIB (1)	EMC (1)
USARADB (2)	Yuma Test Sta (2)
USAAVNBD (1)	USACA (3)
USABELCTBD (1)	USASSA (20)
USAATBD (1)	USASSAMRO (1)
ARADCOM (2)	USASEA (1)
ARADCOM Rgn (2)	USA Carib Sig Agcy (1)
OS Maj Comd (3)	USA Sig Msl Spt Agcy (13)
OS Base Comd (2)	Sig Fld Maint Shops (3)
LOGCOMD (2)	USA Corps (3)
MDW (1)	AFSSC (1)
Armies (2)	JBUSMC (2)
Corps (2)	Units org under fol TOE:
Instl (2)	2 copies to each UNOINDC:
Ft Monmouth (63)	11-7
USATC AD (2)	11-16
USATC Armor (2)	11-57
USATC Engr (2)	11-98
USATC Inf (2)	11-117
USATC FA (2)	11-155
USAOMC (3)	11-157
Svc College (2)	11-500 (AA-AE) (4)
Br Svc Sch (2)	11-557
GENDEP (2) except	11-587
Atlanta GENDEP (None)	11-592
Sig Sec, GENDEP (5)	11-597
Sig Dep (12)	

NG: None.

USAR: None.

For explanation of abbreviations used, see AR 320-50.