

SPECIFICATION FOR LCD MODULE

Model No. TM12232BBC6

Prepared by:	Date:
Checked by :	Date:
Verified by :	Date:
Approved by:	Date:

TIANMA MICROELECTRONICS CO., LTD

REVISION RECORD

Date	Ref. Page	Revision No.	Revision Items	Check & Approval

1. General Specifications:

1.1 Display type:	STN
1.2 Display color* ¹ :	
Display color:	Blue-Black
Background* ² :	Yellow-Green
1.3 Polarizer mode:	Transflective/Positive
1.4 Viewing Angle:	6:00
1.5 Driving Method:	1/32 Duty 1/6 Bias
1.6 Backlight:	LED
1.7 Controller:	SED1520D0A OR NJU6450AC
1.8 Data Transfer:	8 Bit Parallel
1.9 Operating Temperature:	0----+50°C
Storage Temperature:	-20----+60°C
1.10 Outline Dimensions:	Refer to outline drawing on next page
1.11 Dot Matrix:	122 X 32 Dots
1.12 Dot Size:	0.36 X 0.41(mm)
1.13 Dot Pitch:	0.40 X 0.45 (mm)
1.14 Weight:	50g(Approx.)

*¹ Color tone is slightly changed by temperature and driving voltage.

*² Color tone will be changed by backlight.

2. Outline Drawing

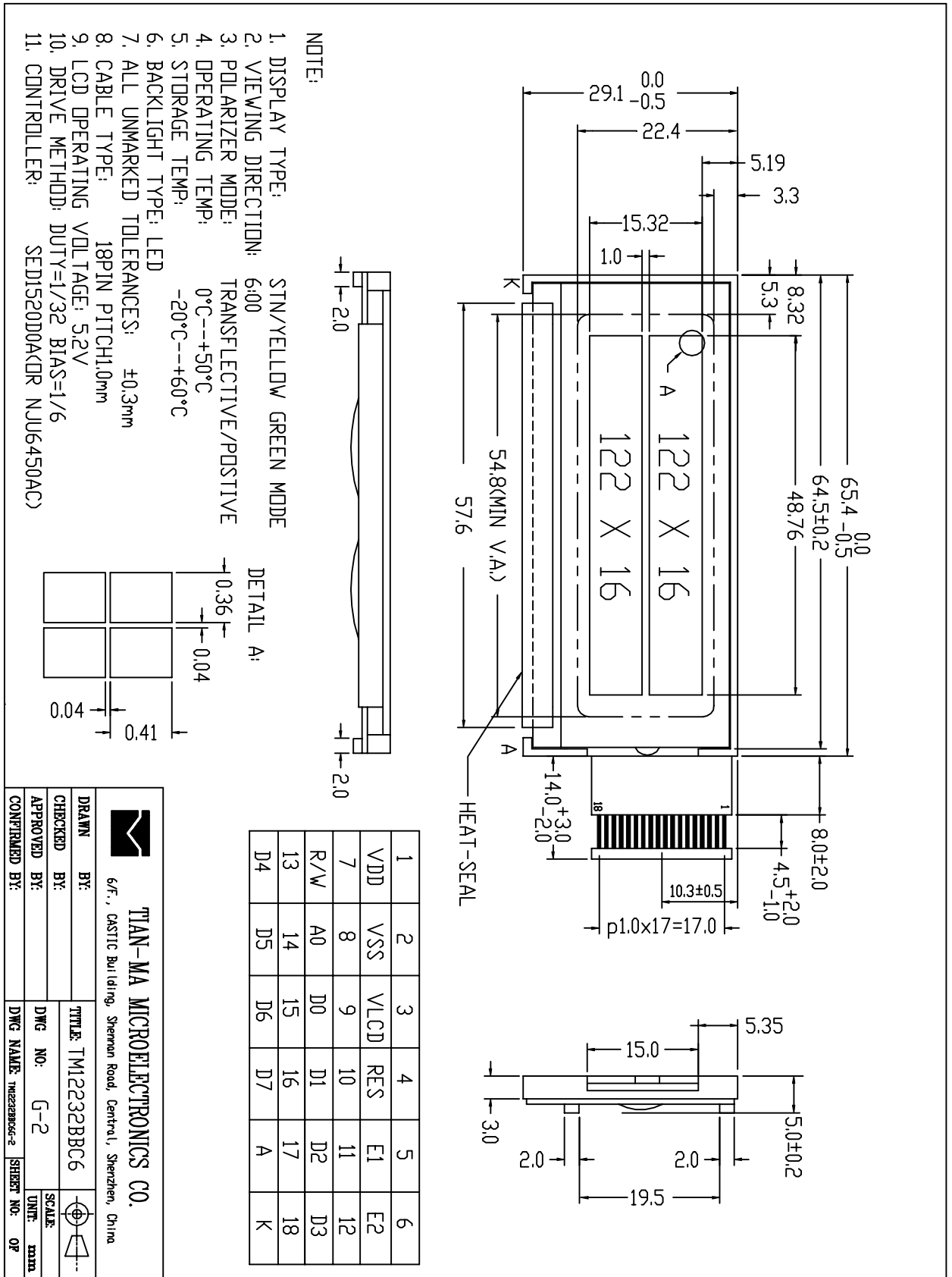

3. LCD Module Part Numbering System

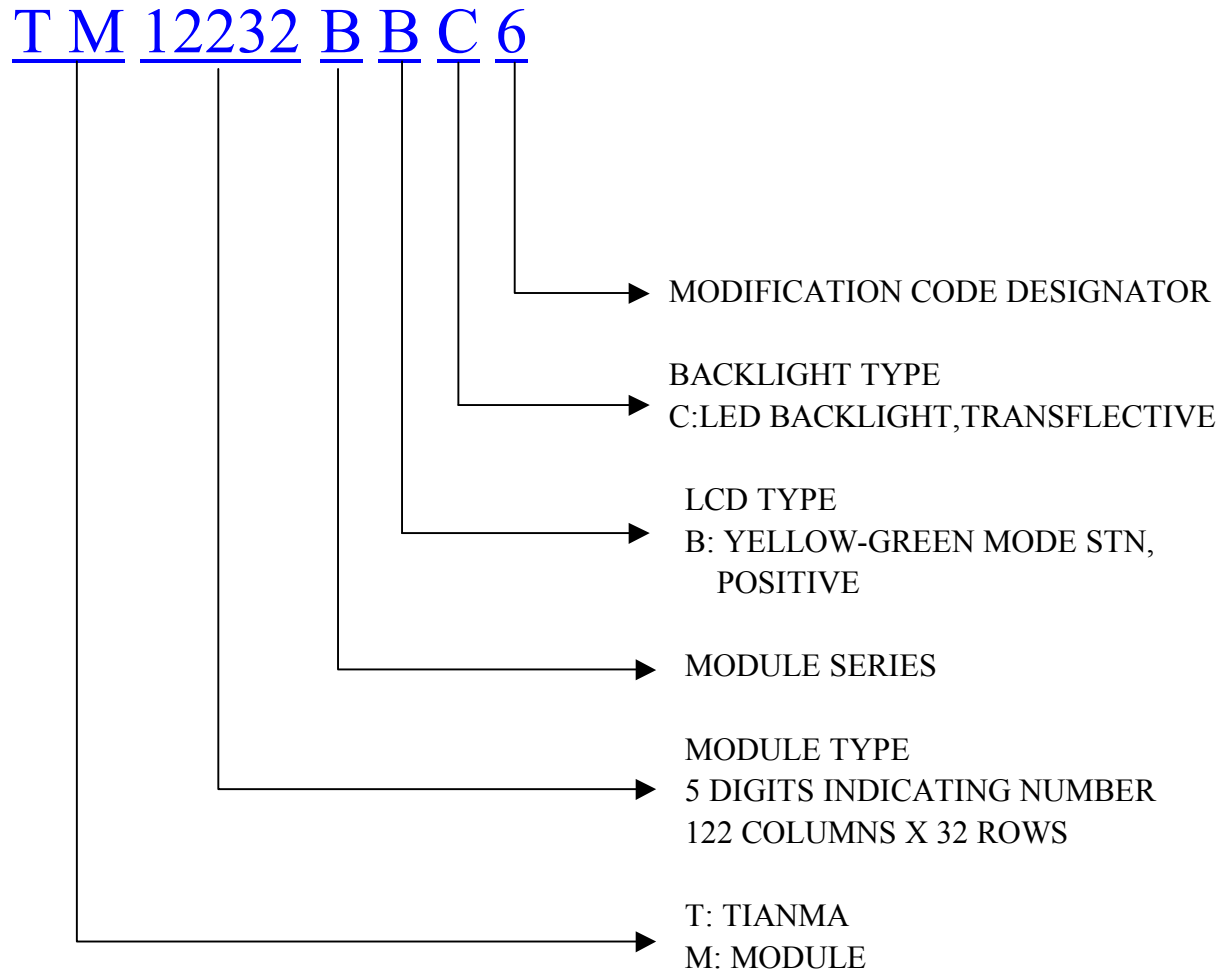

4. Circuit Block Diagram

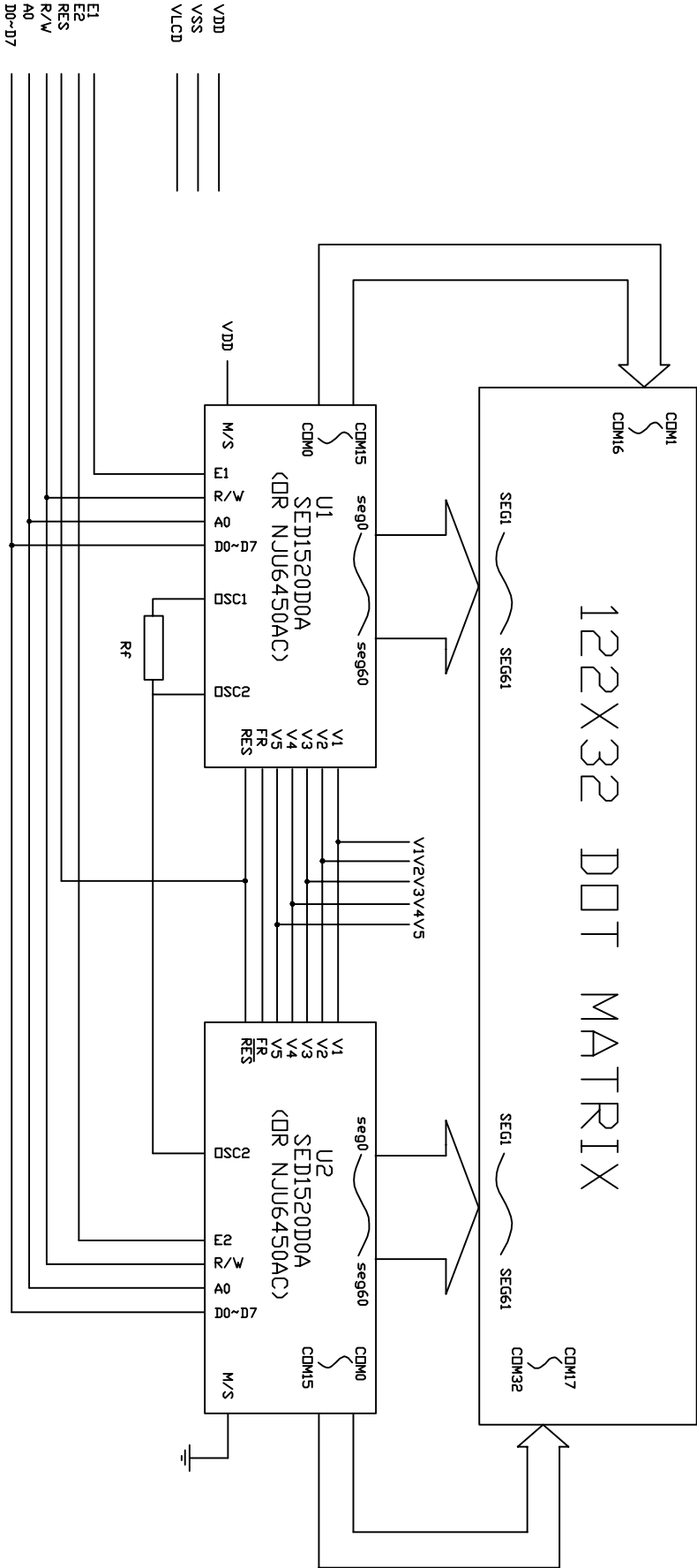

5. Absolute Maximum Ratings

Item	Symbol	Min.	Max.	Unit	Remark
Power Supply Voltage	$V_{DD}-V_{SS}$	-0.3	7.0	V	
LCD Driving Voltage	V_{LCD}	-0.3	13.0		
Operating Temperature Range	T_{OP}	0	+50	°C	No Condensation
Storage Temperature Range	T_{ST}	-20	+60		

6. Electrical Specifications and Instruction Code

6.1 Electrical characteristics

Item	Symbol	Min.	Typ.	Max.	Unit
Supply Voltage (Logic)	$V_{DD}-V_{SS}$	4.5	5.0	5.5	V
Supply Voltage (LCD Drive)	V_{LCD}	-	5.2	-	V
Input Signal Voltage	High V_{IH} ($V_{DD}=5.0$)	$0.7V_{DD}$	-	$V_{DD}+0.3$	V
	Low V_{IL} ($V_{DD}=5.0$)	-0.3	-	$0.2V_{DD}$	V
Supply current (Logic)	I_{DD} ($V_{DD}-V_{SS}=5.0$)	-	-	5.5	mA
Supply current (LCD Drive)	I_{EE}	-	-	1.0	mA
Supply current (LED)	I_{LED}	-	-	100	mA

6.2 Interface Signals

Pin No.	Symbol	Level	Description
1	VDD	5.0V	Power supply voltage for logic and LCD(+)
2	VSS	0V	Ground
3	VLCD	-0.2V	Power supply voltage for LCD(-)
4	RES	H/L	Reset Signal
5	E1	H/L	Read/Write enable Signal for IC1
6	E2	H/L	Read/Write enable Signal for IC2
7	R/W	H/L	Read/Write Select Signal
8	A0	H/L	H: Display Data L: Instructions
9	D0	H/L	Data Bus Line
10	D1	H/L	Data Bus Line
11	D2	H/L	Data Bus Line
12	D3	H/L	Data Bus Line
13	D4	H/L	Data Bus Line
14	D5	H/L	Data Bus Line
15	D6	H/L	Data Bus Line
16	D7	H/L	Data Bus Line
17	A	4.2V	Power supply voltage for LED(+)
18	K	0	Power supply voltage for LED(-)

6.3 Interface Timing Chart

AC Characteristics ($V_{DD}=4.5V\sim 5.5V, T_a=-20\sim +75\text{ }^{\circ}C$)

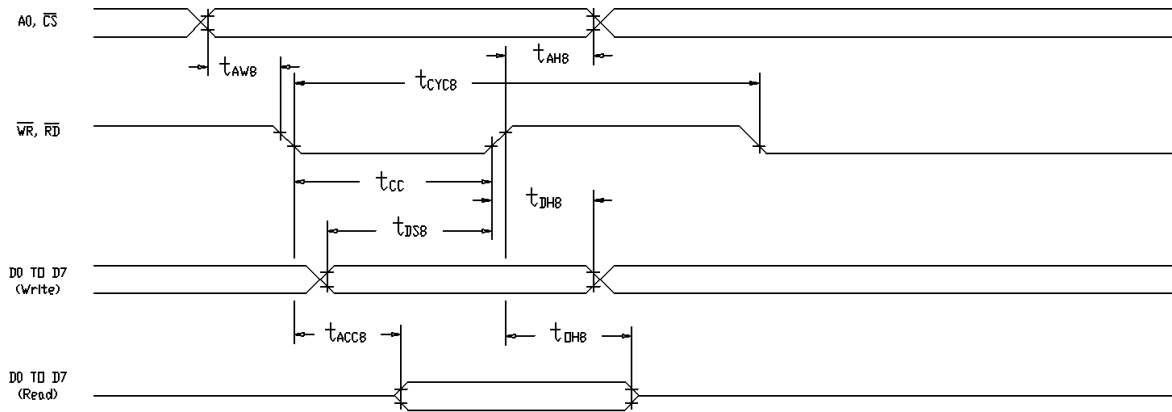

$T_a = -20$ to 75 deg. C

Signal	Symbol	Parameter	$V_{DD}=4.5$ to $5.5V$		$V_{DD}=2.7$ to $5.5V$		Unit	Condition
			min	max	min	max		
A0, \overline{CS}	t _{AH8}	Address hold time	10	-	10	-	ns	CL=100pF
	t _{AW8}	Address setup time	0	-	0	-	ns	
$\overline{WR}, \overline{RD}$	t _{CYC8}	System cycle time	See note.	-	See note.	-	ns	
	t _{CC}	Strobe pulsewidth	120	-	150	-	ns	
D0 to D7	t _{DS8}	Data setup time	120	-	120	-	ns	
	t _{DH8}	Data hold time	5	-	5	-	ns	
	t _{ACC8}	\overline{RD} access time	-	50	-	80	ns	
	t _{OH8}	Output disable time	10	50	10	55	ns	

Note

For memory control and system control commands:

$$t_{CYC8} = 2 t_c + t_{CC} + t_{CEA} + 75 > t_{ACV} + 245$$

for all other commands:

$$t_{CYC8} = 4 t_c + t_{CC} + 30$$

6800 family interface timing

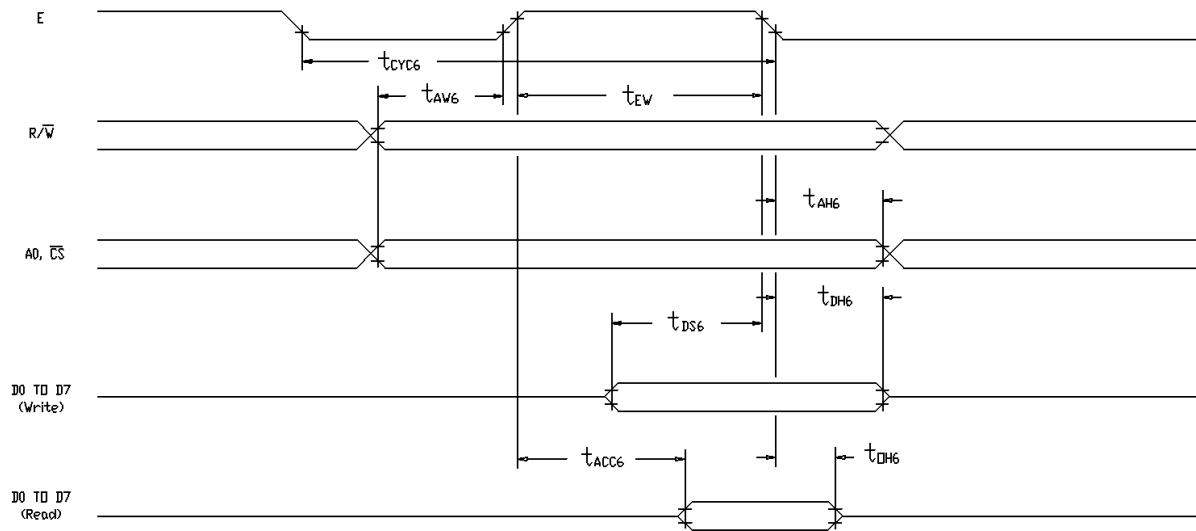

Note

t_{CYC6} indicates the interval during which CS is LOW and E is HIGH

Ta=-20 to 75 deg. C

Signal	Symbol	Parameter	$V_{DD}=4.5$ to $5.5V$		$V_{DD}=2.7$ to $5.5V$		Unit	Condition
			min	Max	min	max		
A0, \overline{CS}	t_{CYC6}	System cycle time	See note.	-	See note.	-	ns	CL=100pF
	t_{AW6}	Address setup time	0	-	10	-	ns	
$\overline{R/W}$	t_{AH6}	Address hold time	0	-	0	-	ns	
D0 to D7	t_{DS6}	Data setup time	100	-	120	-	ns	
	t_{DH6}	Data hold time	0	-	0	-	ns	
	t_{OH6}	Output disable time	10	50	10	75	ns	
	t_{ACC6}	Access time	-	85	-	130	ns	
E	t_{EW}	Enable pulsewidth	120	-	150	-	ns	

Note

For memory control and system control commands:

$$t_{CYC8} = 2 t_C + t_{CC} + t_{CEA} + 75 > t_{ACV} + 245$$

for all other commands:

$$t_{CYC8} = 4 t_C + t_{EW} + 30$$

6.4 Instruction Code

Command	Code											Command description	
	RD	WR	A0	D7	D6	D5	D4	D3	D2	D1	D0		
Display On/Off	1	0	0	1	0	1	0	1	1	1	0/1	Switch the entire display on or off	
Display Start Line	1	0	0	1	1	0	Display start line					Determine the line of RAM data to be displayed at the display top line(COM0)	
Page Address Set	1	0	0	1	0	1	1	1	0	Page (0-3)		Sets the page of the display RAM in the page address register	
Column(SEG) Address Set	1	0	0	0	0 Column Address (0 - 79)								Set the column address of the display RAM in the column address register
Status Read	0	1	0	Busy	ADC	ON/OFF	RESET	0	0	0	0	Read the status	
Write Display Data	1	0	1	Write Data									Write Data on the data bus to RAM
Read Display Data	0	1	1	Read Data									Read Data on the data bus to RAM
ADC Select	1	0	0	1	0	1	0	0	0	0	0/1	Used to reverse the correspondence between the display RAM's column addresses and segment driver output ports (0:forward 1:reverse)	
Static Drive On/Off	1	0	0	1	0	1	0	0	1	0	0/1	Select normal display operation or static all-lit drive display operation (0::normal 1:static drive*)	
Duty Select	1	0	0	1	0	1	0	1	0	0	0/1	Select the duty factor for driving LCD cells (0;1/16 1;1/32)	
Read Modify Write	1	0	0	1	1	1	0	0	0	0	0	Increment the column address counter by one only when display data is written but not when it is read	
End	1	0	0	1	1	1	0	1	1	1	0	Cancel the read modify write mode	
Reset	1	0	0	1	1	1	0	0	0	1	0	Reset the display	

* Power Save mode is entered by selecting static drive in the Display OFF status

Notes

7. Optical Characteristics

7.1 Optical Characteristics

Ta=25°C

Item	Symbol	Condition	Min.	Typ.	Max.	Unit	
Viewing Angle	θ_x	$C_r \geq 2$	$\theta_y = 0^\circ$	-35	--	20	Deg
	θ_y		$\theta_x = 0^\circ$	-30	--	30	
Contrast Ratio	C_r	$\theta_x = 0^\circ$ $\theta_y = 0^\circ$	4.0	-	-		
Response Time	Turn on	T_{on}	$\theta_x = 0^\circ$ $\theta_y = 0^\circ$	-	-	250	ms
	Turn off	T_{off}		-	-	250	

7.2 Definition of Optical Characteristics

7.2.1 Definition of Viewing Angle

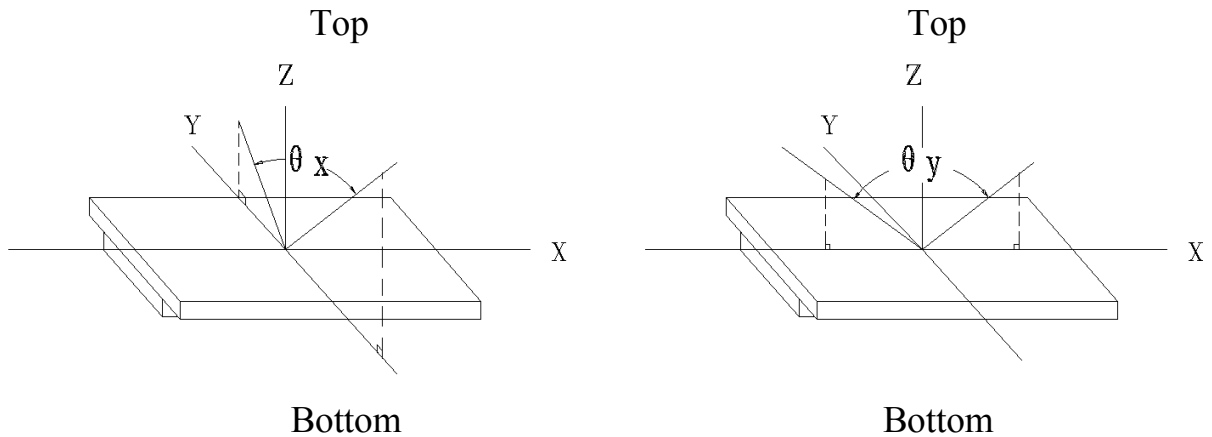

7.2.2 Definition of Contrast Ratio

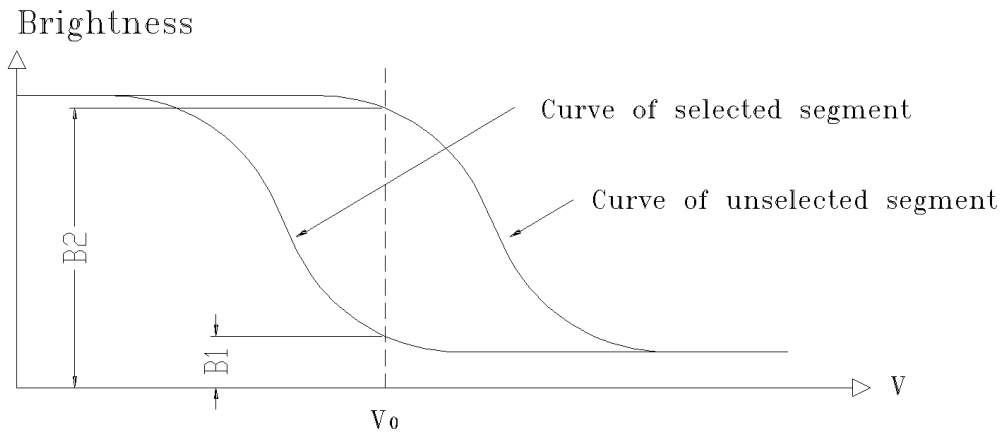

$$\text{Contrast Ratio} = B2/B1 = \frac{\text{unselected state brightness}}{\text{selected state brightness}}$$

Measuring Conditions:

- 1) Ambient Temperature: 25°C ;
- 2) Frame frequency: 64.0Hz

7.2.3 Definition of Response time

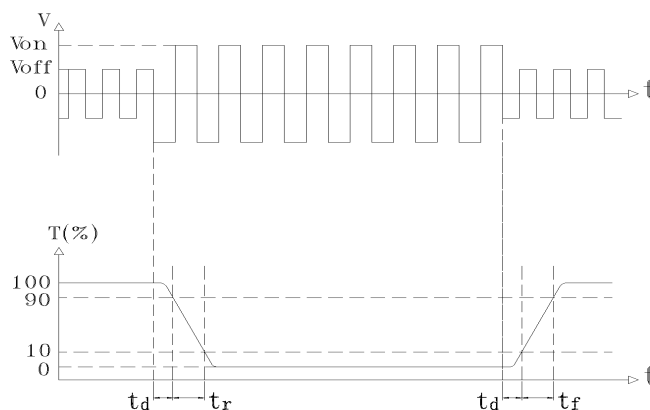

Turn on time: $t_{on} = t_d + t_r$

Turn off time: $t_{off} = t_d + t_f$

Measuring Condition:

- 1) Operating Voltage: 5.2V

- 2) Frame frequency: 64.0Hz

8. Reliability

8.1 Content of Reliability Test

Ta=25°C

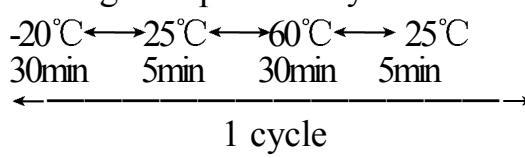
No.	Test Item	Content of Test	Test condition
1	High Temperature Storage	Endurance test applying the high storage temperature for a long time	60°C 96H
2	Low Temperature Storage	Endurance test applying the low storage temperature for a long time	-20°C 96H
3	High Temperature Operation	Endurance test applying the electric stress (voltage & current) and the thermal stress to the element for a long time	50°C 96H
4	Low Temperature Operation	Endurance test applying the electric stress under low temperature for a long time	0°C 96H
5	High Temperature /Humidity Storage	Endurance test applying the high temperature and high humidity storage for a long time	40°C 90%RH 96H
6	Temperature Cycle	Endurance test applying the low and high temperature cycle 	-20°C/60°C 10 cycles
7	Vibration Test (package state)	Endurance test applying the vibration during transportation	10Hz~150Hz, 50m/s ² , 40min
8	Shock Test (package state)	Endurance test applying the shock during transportation	Half-sinewave, 100m/s ² , 11ms
9	Atmospheric Pressure Test	Endurance test applying the atmospheric pressure during transportation by air	40kPa 16H

8.2 Failure Judgment Criterion

Criterion Item	Test Item No.									Failure Judgment Criterion
	1	2	3	4	5	6	7	8	9	
Basic Specification	√	√	√	√	√	√	√	√	√	Out of the basic Specification
Electrical specification	√	√	√	√	√					Out of the electrical specification
Mechanical Specification							√	√		Out of the mechanical specification
Optical Characteristic	√	√	√	√	√	√			√	Out of the optical specification
Note	For test item refer to 8.1									
Remark	Basic specification = Optical specification + Mechanical specification									

9. QUALITY LEVEL

Examination or Test	At Ta=25°C (unless otherwise stated)	Inspection				
		Min.	Max.	Unit	IL	AQL
External Visual Inspection	Under normal illumination and eyesight condition, the distance between eyes and LCD is 25cm.	See Appendix A			II	Major 1.0 Minor 2.5
Display Defects	Under normal illumination and eyesight condition, display on inspection.	See Appendix B			II	Major 1.0 Minor 2.5
<p>Note: Major defects: Open segment or common, Short, Serious damages, Leakage Minor defects: Others Sampling standard conforms to GB2828</p>						

10. Precautions for Use of LCD Modules

10.1 Handling Precautions

10.1.1 The display panel is made of glass. Do not subject it to a mechanical shock by dropping it from a high place, etc.

10.1.2 If the display panel is damaged and the liquid crystal substance inside it leaks out, be sure not to get any in your mouth, if the substance comes into contact with your skin or clothes, promptly wash it off using soap and water.

10.1.3 Do not apply excessive force to the display surface or the adjoining areas since this may cause the color tone to vary.

10.1.4 The polarizer covering the display surface of the LCD module is soft and easily scratched. Handle this polarizer carefully.

10.1.5 If the display surface is contaminated, breathe on the surface and gently wipe it with a soft dry cloth. If still not completely clear, moisten cloth with one of the following solvents:

- Isopropyl alcohol
- Ethyl alcohol

Solvents other than those mentioned above may damage the polarizer. Especially, do not use the following:

- Water
- Ketone
- Aromatic solvents

10.1.6 Do not attempt to disassemble the LCD Module.

10.1.7 If the logic circuit power is off, do not apply the input signals.

10.1.8 To prevent destruction of the elements by static electricity, be careful to maintain an optimum work environment.

- a. Be sure to ground the body when handling the LCD Modules.
- b. Tools required for assembly, such as soldering irons, must be properly ground.
- c. To reduce the amount of static electricity generated, do not conduct assembly and other work under dry conditions.
- d. The LCD Module is coated with a film to protect the display surface. Be care when peeling off this protective film since static electricity may be generated.

10.2 Storage precautions

10.2.1 When storing the LCD modules, avoid exposure to direct sunlight or to the light of fluorescent lamps.

10.2.2 The LCD modules should be stored under the storage temperature range. If the LCD modules will be stored for a long time, the recommend condition is:

Temperature : $0^{\circ}\text{C} \sim 40^{\circ}\text{C}$

Relatively humidity: $\leq 80\%$

10.2.3 The LCD modules should be stored in the room without acid, alkali and harmful gas.

10.3 The LCD modules should be no falling and violent shocking during transportation, and also should avoid excessive press, water, damp and sunshine.

Appendix A

Inspection items and criteria for appearance defects

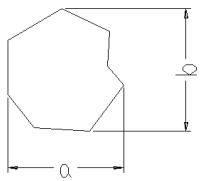
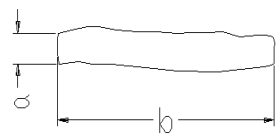
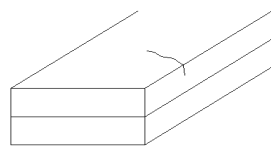
Items	Contents	Criteria			
Leakage		Not permitted			
Rainbow		According to the limit specimen			
Polarizer	Wrong polarizer attachment	Not permitted			
	Bubble between polarizer and glass	Not counted	Max. 3 defects allowed		
		$\phi < 0.3\text{mm}$	$0.3\text{mm} \leq \phi \leq 0.5\text{mm}$		
	Scratches of polarizer	According to the limit specimen			
Black spot (in viewing area)		Not counted	Max. 3 spots allowed	Max. 3 spots (lines) allowed	
		$X < 0.20\text{mm}$	$0.20\text{mm} \leq X \leq 0.5\text{mm}$		
		$X = (a+b)/2$			
Black line (in viewing area)		Not counted	Max. 3 lines allowed	Max. 3 spots (lines) allowed	
		$a < 0.02\text{mm}$	$0.02\text{mm} \leq a \leq 0.05\text{mm}$ $b \leq 2.0\text{mm}$		
Progressive cracks		Not permitted			

Appendix B

Inspection items and criteria for display defects

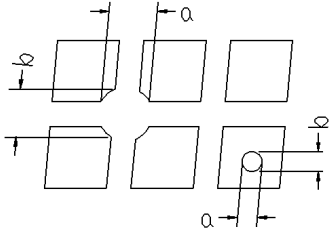
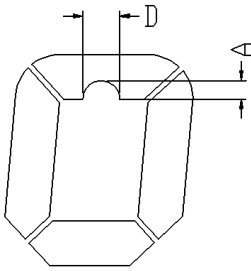
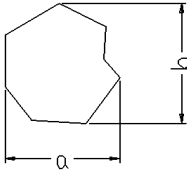
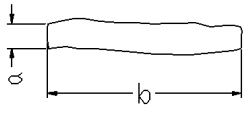
Items	Contents	Criteria				
Open segment or open common		Not permitted				
Short		Not permitted				
Wrong viewing angle		Not permitted				
Contrast ratio uneven		According to the limit specimen				
Crosstalk		According to the limit specimen				
Pin holes and cracks in segment (DOT)		Not counted	Max.3 dots allowed	Max.3 dots allowed		
		$X < 0.1\text{mm}$	$0.1\text{mm} \leq X \leq 0.2\text{mm}$			
		$X = (a+b)/2$				
		Not counted	Max.2 dots allowed			
$A < 0.1\text{mm}$	$0.1\text{mm} \leq A \leq 0.2\text{mm}$ $D < 0.25\text{mm}$					
Black spot (in viewing area)		Not counted	Max.3 spots allowed		Max.3 spots (lines) allowed	
		$X < 0.1\text{mm}$	$0.1\text{mm} \leq X \leq 0.2\text{mm}$			
		$X = (a+b)/2$				
Black line (in viewing area)		Not counted	Max.3 lines allowed			
		$a < 0.02\text{mm}$	$0.02\text{mm} \leq a \leq 0.05\text{mm}$ $b \leq 0.5\text{mm}$			

Appendix B

Inspection items and criteria for display defects (continued)

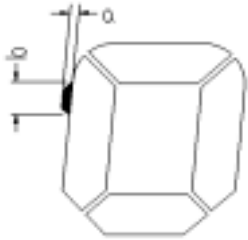
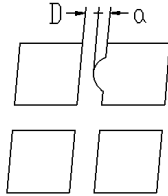
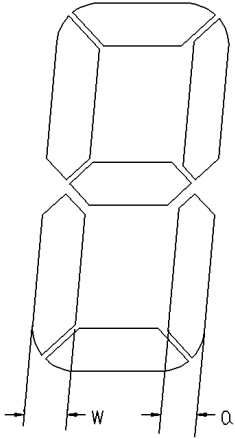
Items	Content	Criteria	
Transformation of segment		Not counted	Max. 2 defects allowed
		$x < 0.1\text{mm}$	$0.1\text{mm} \leq x \leq 0.2\text{mm}$
		$x = (a+b)/2$	
		Not counted	Max. 1 defects allowed
		$a < 0.1\text{mm}$	$0.1\text{mm} \leq a \leq 0.2\text{mm}$ $D > 0$
		<p>Max.2 defects allowed</p> $0.8W \leq a \leq 1.2W$ <p>a=measured value of width W=nominal value of width</p>	