

TIAN-MA
MICROELECTRONICS CO., LTD

DEVICE SPECIFICATION FOR LCD MODULE

Model No. TM12232ECA6

Prepared by: 梁斌	Date: 99.10.13.
Checked by: 潘武	Date: 13/10-99
Verified by: 王彩荣	Date: 14/10-99
Approved by: [Signature]	Date: 15/10-99

To: _____

CUSTOMER'S APPROVAL

DATE _____

By: _____

Presented

By: _____

Sell and Market Dep.

TIAN-MA MICRO ELECTRONICS
CO., LTD



REVISION RECORD

Date	Ref. Page	Revision No.	Revision Items	Check & Approval

模块部
受控文件

1 Display Specifications

1.1 Display type: STN

1.2 Display color*:

Display color: Blue-Black

Background color: Black-White

1.3 Polarizer mode: Reflective/Positive

1.4 Viewing Angle: 6:00

1.5 Driving Duty: 1/32

1.6 Backlight: None

* Color tone is slightly changed by temperature and driving voltage.

2 Mechanical Specifications

2.1 Outline Dimensions: Refer to outline drawing on page: 2

2.2 Dot Matrix: 122×32

2.3 Dot size: 0.38×0.38(mm)

2.4 Dot pitch: 0.43×0.43(mm)

2.5 Weight: 50g

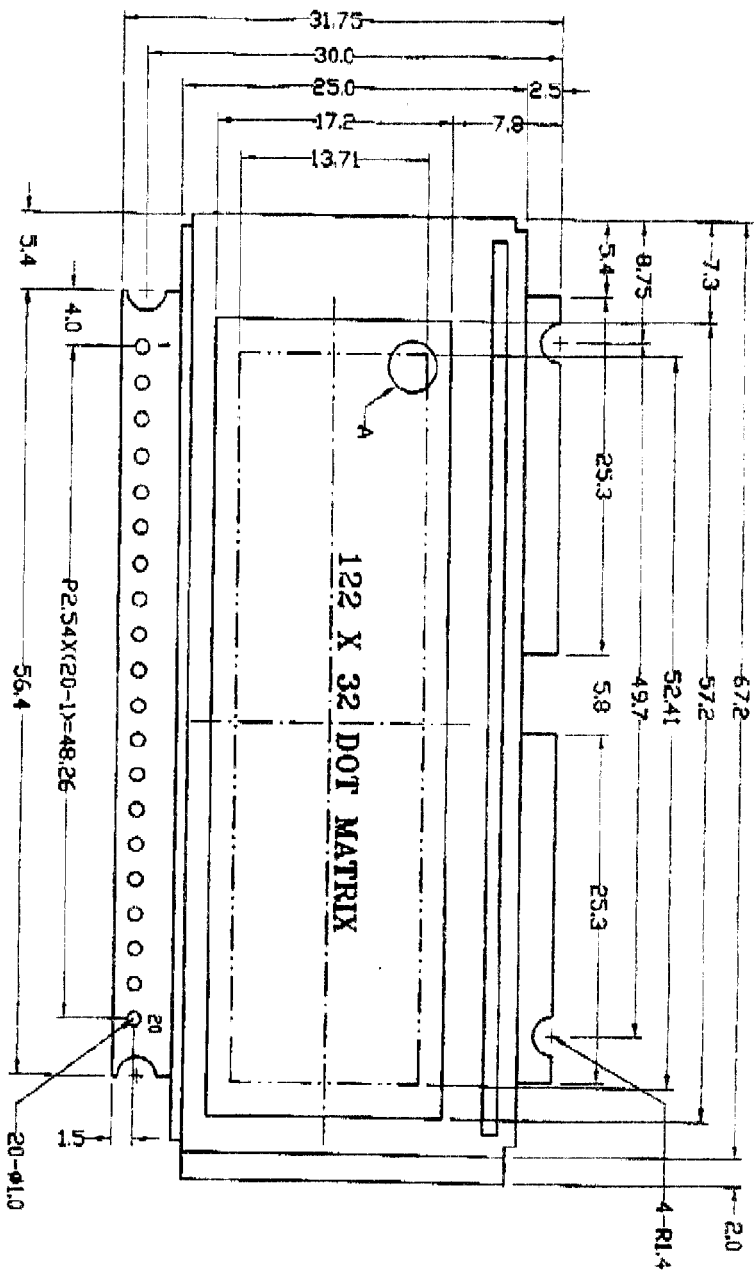

1	2	3	4	5	6	7	8	9	10	11	12	13	14	15	16	17	18	19	20
VSS	Vdd	V0	Vout	A0	E1	E2	D0	D1	NC	NC	D2	D3	D4	D5	D6	D7	NC	NC	NC

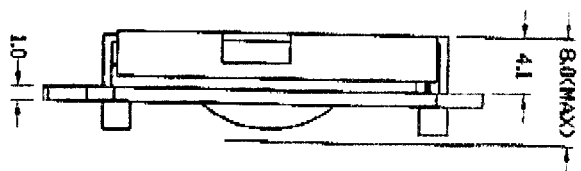

DETAIL A:

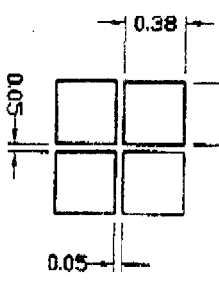

3 Circuit Block Diagram

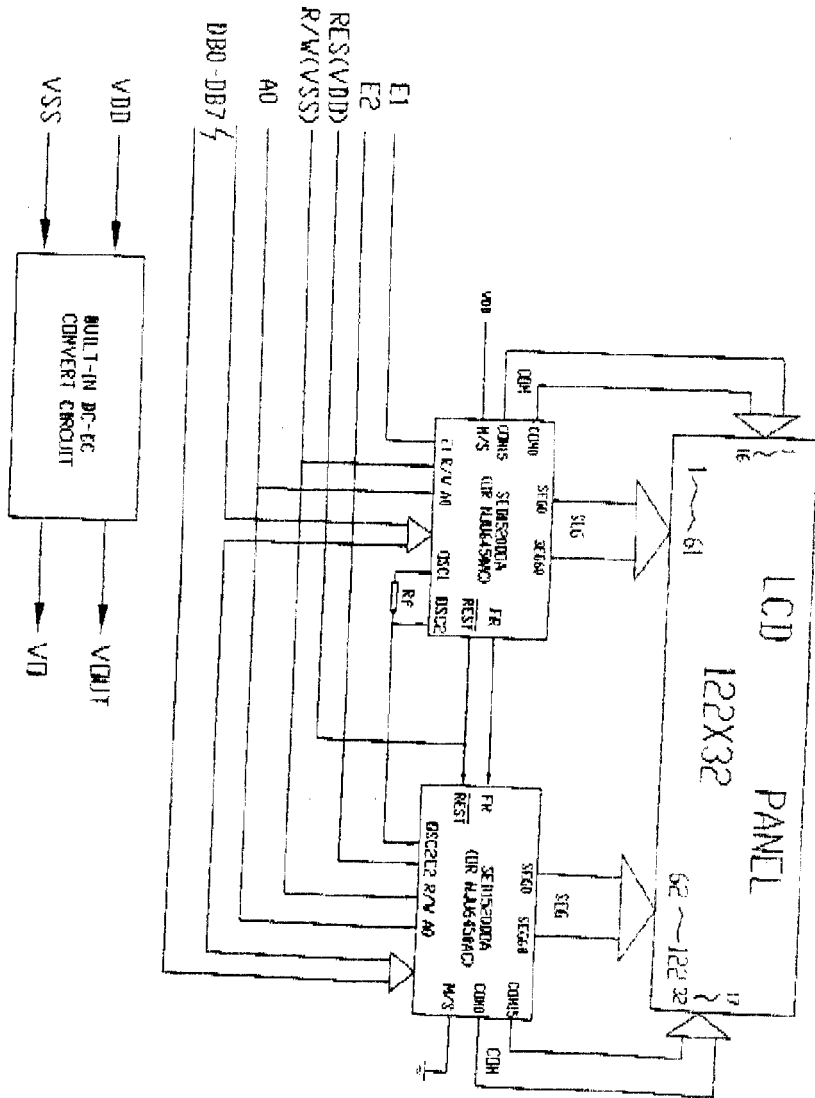

4 Absolute Maximum Ratings

Item	Symbol	Min.	Max.	Unit	Remark
Power Supply Voltage	$V_{DD}-V_{SS}$	0	6.5	V	
LCD Driving Voltage	$V_{DD}-V_{EE}$	-	10.0		
Operating Temperature Range	T_{OP}	0	+50	°C	No Condensation
Storage Temperature Range	T_{ST}	-20	+60		

5 Electrical Specifications and Instruction Code

5.1 Electrical characteristics

Item	Symbol	Min.	Typ.	Max.	Unit	Remark	
Supply Voltage (Logic)	$V_{DD}-V_{SS}$	4.5	5.0	5.5	V		
Supply Voltage (LCD Drive)	$V_{SS}-V_{EE}$	-	0.9	-	V		
Input Signal Voltage	'H'Level	V_{IH}	$0.7V_{DD}$	-	V_{DD}	V	
	'L'Level	V_{IL}	0	-	$0.3V_{DD}$	V	
Supply current (Logic)	I_{DD}	-	2.5	-	mA		
Supply current (LCD Drive)	I_{EE}	-	2.0	-	mA		

5.3 Interface Signals:

Pin No.	Symbol	Level	Description
1	V _{SS}	0V	Ground
2	V _{DD}	5.0V	Power supply voltage for logic and LCD(+)
3	V ₀	-0.9V	Power supply voltage for LCD(-)
4	V _{out}	-10.0V	Built-in DC-DC Convert Circuit Output
5	A0	H/L	Select registers
6	E1	H/L	Enable signal1
7	E2	H/L	Enable signal2
8	D0	H/L	Data bit0
9	D1	H/L	Data bit1
10	NC		No Connection
11	NC		No Connection
12	D2	H/L	Data bit2
13	D3	H/L	Data bit3
14	D4	H/L	Data bit4
15	D5	H/L	Data bit5
16	D6	H/L	Data bit6
17	D7	H/L	Data bit7
18	NC		No Connection
19	NC		No Connection
20	NC		No Connection

5.3 Interface Timing Chart:

○ Control timing for 80-port/68-port display

($T_A = -20$ to 75°C , $V_{SS} = -5.0\text{V} \pm 10\%$)

Item	Signal	Symbol	Condition	Min	Typ	Max	Unit
LOW pulse width	CL	tWLC		35	-	-	μs
HIGH pulse width		tWHCL		35	-	-	μs
Rising time		t _r		-	30	150	ns
Falling time		t _f		-	30	150	ns
FR delay time	FR	t _{DFR}	(Input timing)	-2.0	0.2	2.0	μs
			(Output timing, $C_L = 100\text{pF}$)		0.2	0.4	

* 5 The ratings when $V_{SS} = -3.0\text{V}$ are approximately 100% higher than when $V_{SS} = -5.0\text{V}$.

* 6 The input timing of the FR delay time is determined by the SED1520 (Slave).

The output timing of the FR delay time is determined by the SED1520 (Master).

● Timing Chart

○ Read/Write timing for the 80-port MPU

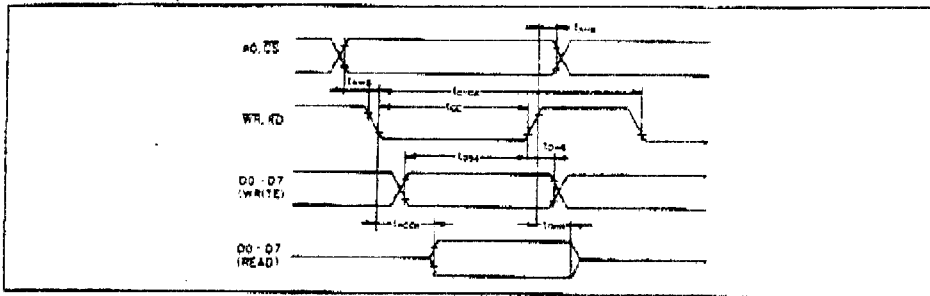

○ Read/Write timing for the 68-port MPU

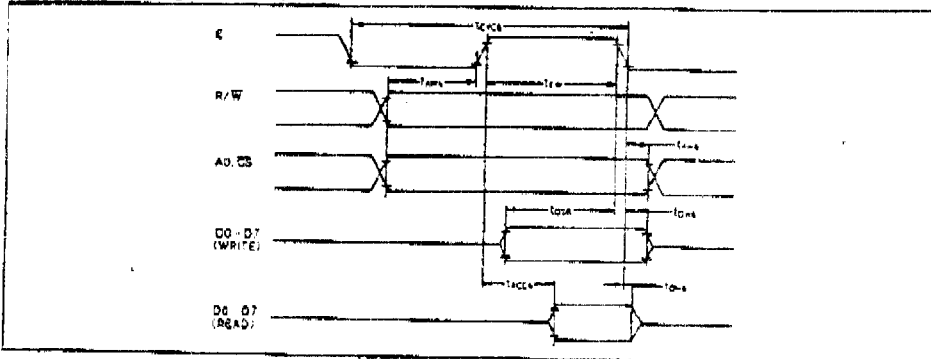

○ Control timing for 80-port/68-port display

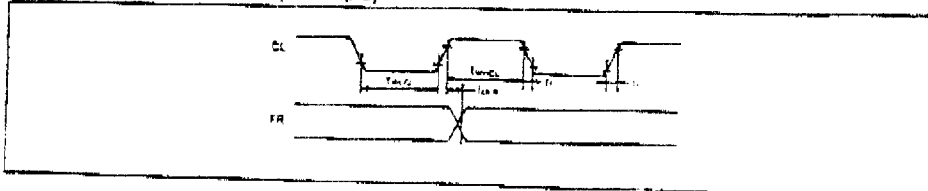

5.4 Instruction Code

■ DISPLAY COMMANDS (Based on the 80-port MPU; the RD and WR commands differ for the 68-port MPU.)

Command	R	D	W	A0	D7	D6	D5	D4	D3	D2	D1	D0	Function
1 Display ON/OFF	1	0	0		1	0	1	0	1	1	1	0/1	Switches the entire display ON or OFF, regardless of the Display RAM's data or the internal status. *7
2 Display START Line	1	0	0		1	1	0	Display START address (0~31)				Determines the line of RAM data to be displayed at the display's top line (COM0).	
3 Page Address Set	1	0	0		1	0	1	1	1	0	Page (0~3)		Sets the page of the Display RAM in the page address register.
4 Column (Segment) Address Set	1	0	0		0	Column address (0~79)						Sets the column address of the Display RAM in the column address register.	
5 Status Read	0	1	0		BUSY	ACC	ON/OFF	RESET	0	0	0	0	Reads the status. BUSY 1: Busy (internal processing) 0: READY status ACC 1: Rightward (forward) output ON/OFF 0: Leftward (reverse) output RESET 1: Resetting ON/OFF 1: Display OFF 0: Display ON RESET 1: Resetting 0: Normal
6 Write Display Data	1	0	1		Write Data						Writes the data on the data bus to RAM.	These commands access a previously-specified address of the Display RAM, after which the column address is incremented by one.	
7 Read Display Data	0	1	1		Read Data						Reads data from the Display RAM onto the data bus.		
8 ADC Select	1	0	0		1	0	1	0	0	0	0	0/1	Used to reverse the correspondence between the Display RAM's column addresses and segment driver output ports. 0: Rightward (forward) output 1: Leftward (reverse) output
9 Static Drive ON/OFF	1	0	0		1	0	1	0	0	1	0	0/1	Selects normal display operation or static all-bit drive display operation. 1: Static drive (Power Save) * 0: Normal display operation
10 Duty Select	1	0	0		1	0	1	0	1	0	0	0/1	Selects the duty factor for driving LCD cells. 1: 1/32 duty 0: 1/16 duty
11 Read Modify Write	1	0	0		1	1	1	0	0	0	0	0	Increments the column address counter by one only when display data is written but not when it is read.
12 End	1	0	0		1	1	1	0	1	1	1	0	Cancels the Ready Modify Write mode.
13 Reset	1	0	0		1	1	1	0	0	0	1	0	Resets the Display START line to the 1st line in the register. Resets the column address counter to 0 and page address register to 3.

*7 Power Save mode is entered by selecting static drive in the Display OFF status.

6. Optical Characteristics

6.1 Optical Characteristics

$T_a=25^{\circ}\text{C}$

Item	Symbol	Condition	Min.	Typ.	Max.	Unit	Remark
Viewing Angle	θ_x	$C_r > 3$	-20	--	20	Deg	
	θ_y						
Contrast Ratio	C_r	$\theta_x=0^{\circ}$ $\theta_y=15^{\circ}$	3.0				
Response Time	Turn on	T_{on}			200	ms	
	Turn off	T_{off}			360		

6.2 Definition of optical characteristics

6.2.1 Definition of viewing Angle(see fig. as follow)

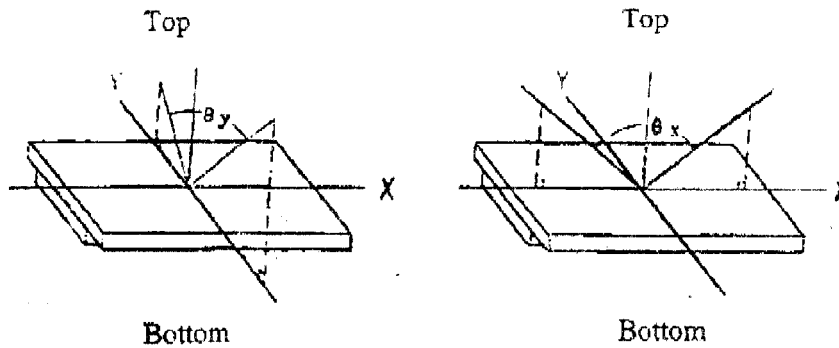

6.2.2 Definition of Contrast Ratio(see fig. as follow)

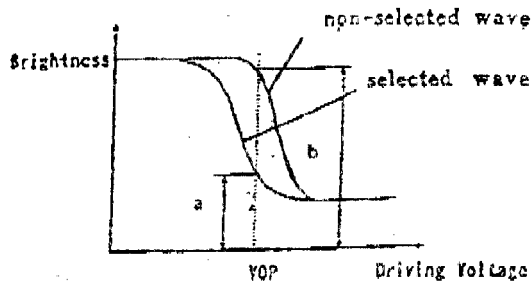

$$\text{Contrast Ratio} = b / a = \frac{\text{non-selected state brightness}}{\text{selected state brightness}}$$

Measuring Conditions:

- 1) Ambient Temperature: 25°C ;
- 2) Frame frequency: 64Hz

6.2.3 Definition of Response time(see fig. as follow)

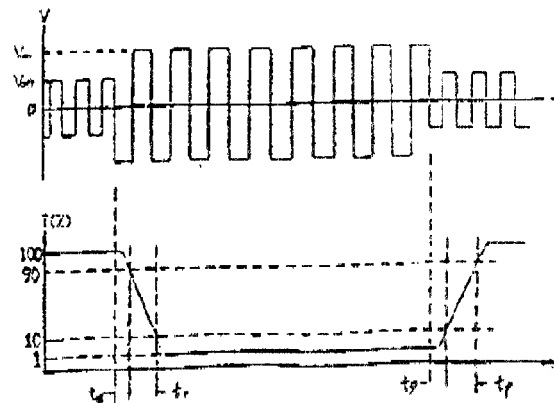

$$\text{Turn-on time: } t_{on} = t_d + t_r$$

$$\text{Turn-off time: } t_{off} = t_d + t_f$$

Measuring Condition:

- 1) Operating Voltage: 5.9V ;
- 2) Frame frequency: 64Hz

7. Reliability

7.1 Content of Reliability Test

($T_{Op}=25^{\circ}C$)

No.	Test Item	Content of Test	Test condition
1	High Temperature Storage	Endurance test applying the high storage temperature for a long time	60°C 500H
2	Low Temperature Storage	Endurance test applying the low storage temperature for a long time	-20°C 500H
3	High Temperature Operation	Endurance test applying the electric stress (voltage & current) and the thermal stress to the element for a long time	50°C 500H
4	Low Temperature Operation	Endurance test applying the electric stress under low temperature for a long time	0°C 500H
5	High Temperature /Humidity Storage	Endurance test applying the high temperature and high humidity storage for a long time	60°C 95%RH 360H
6	Temperature Cycle	Endurance test applying the low and high temperature cycle $-20^{\circ}C \longleftrightarrow 25^{\circ}C \longleftrightarrow 60^{\circ}C \longleftrightarrow 25^{\circ}C$ $30min \quad 5min \quad 30min \quad 5min$ <p style="text-align: center;">←————— 1 cycle —————→</p>	-20°C/60°C 10 cycles
7	Vibration Test (package state)	Endurance test applying the vibration during transportation	10Hz~500Hz, 100m/s ² , 120min
8	Shock Test (package state)	Endurance test applying the shock during transportation	Half-sinewave, 100m/s ² , 11ms
9	Atmospheric Pressure Test	Endurance test applying the atmospheric pressure during transportation by air	25kPa 16H

7.2 Failure Judgment Criterion

Criterion Item	Test Item No.									Failure Judgement Criterion
	1	2	3	4	5	6	7	8	9	
Basic Specification	0	0	0	0	0	0	0	0	0	Out of the basic Specification
Electrical specification	0	0	0	0	0					Out of the electrical specification
Mechanical Specification							0	0		Out of the mechanical specification
Optical Characteristic	0	0	0	0	0	0			0	Out of the optical specification
Remark	Basic specification = Optical specification + Mechanical specification									

8 Precautions for use of LCD Modules

8.1 Handling Precautions

- 8.1.1 The display panel is made of glass. Do not subject it to a mechanical shock by dropping it from a high place, etc.
- 8.1.2 If the display panel is damaged and the liquid crystal substance inside it leaks out, be sure not to get any in your mouth, if the substance comes into contact with your skin or clothes, promptly wash it off using soap and water.
- 8.1.3 Do not apply excessive force to the display surface or the adjoining areas since this may cause the color tone to vary.
- 8.1.4 The polarizer covering the display surface of the LCD module is soft and easily scratched. Handle this polarizer carefully.
- 8.1.5 If the display surface is contaminated, breathe on the surface and gently wipe it with a soft dry cloth. If still not completely clear, moisten cloth with one of the following solvents:
- Isopropyl alcohol
 - Ethyl alcohol
- Solvents other than those mentioned above may damage the polarizer. Especially, do not use the following:
- Water
 - Ketone
 - Aromatic solvents
- 8.1.6 Do not attempt to disassemble the LCD Module.
- 8.1.7 If the logic circuit power is off, do not apply the input signals.
- 8.1.8 To prevent destruction of the elements by static electricity, be careful to maintain an optimum work environment.
- a. Be sure to ground the body when handling the LCD Modules.
 - b. Tools required for assembly, such as soldering irons, must be properly ground.
 - c. To reduce the amount of static electricity generated, do not conduct assembly and other work under dry conditions.
 - d. The LCD Module is coated with a film to protect the display surface. Be care when peeling off this protective film since static electricity may be generated.