

TIANMA
MICROELECTRONICS CO., LTD

DEVICE SPECIFICATION FOR LCD MODULE

Model No. TM128128ADC

Prepared by: 罗邦虎	Date: 6/3-2000
Checked by: 潘武	Date: 7/3-2000
Verified by: 周建	Date: 7/3-2000
Approved by: 马政文	Date: 8/3-2000

To: _____

CUSTOMER'S APPROVAL

DATE _____

By: _____

Presented

By: _____
Sell and Market Dep.

TIANMA MICRO ELECTRONICS
CO., LTD



REVISION RECORD

Date	Ref. Page	Revision No.	Revision Items	Check & Approval

模块部
受控文件

1 Display Specifications

1.1 Display type: STN

1.2 Display color*:

Display color: BLUE-Black

Background: GRAY

1.3 Polarizer mode: Transflective/Positive

1.4 Viewing Angle: 6:00

1.5 Driving Duty: 1/128

1.6 Backlight: LED

* Color tone is slightly changed by temperature and driving voltage.

2 Mechanical Specifications

2.1 Outline Dimensions: Refer to outline drawing on page: 2

2.2 Dot Matrix: 128X128

2.3 Dot Size: 0.40X0.40(mm)

2.4 Dot Pitch: 0.43X0.43 (mm)

2.5 Weight: 180 g

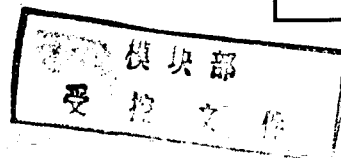

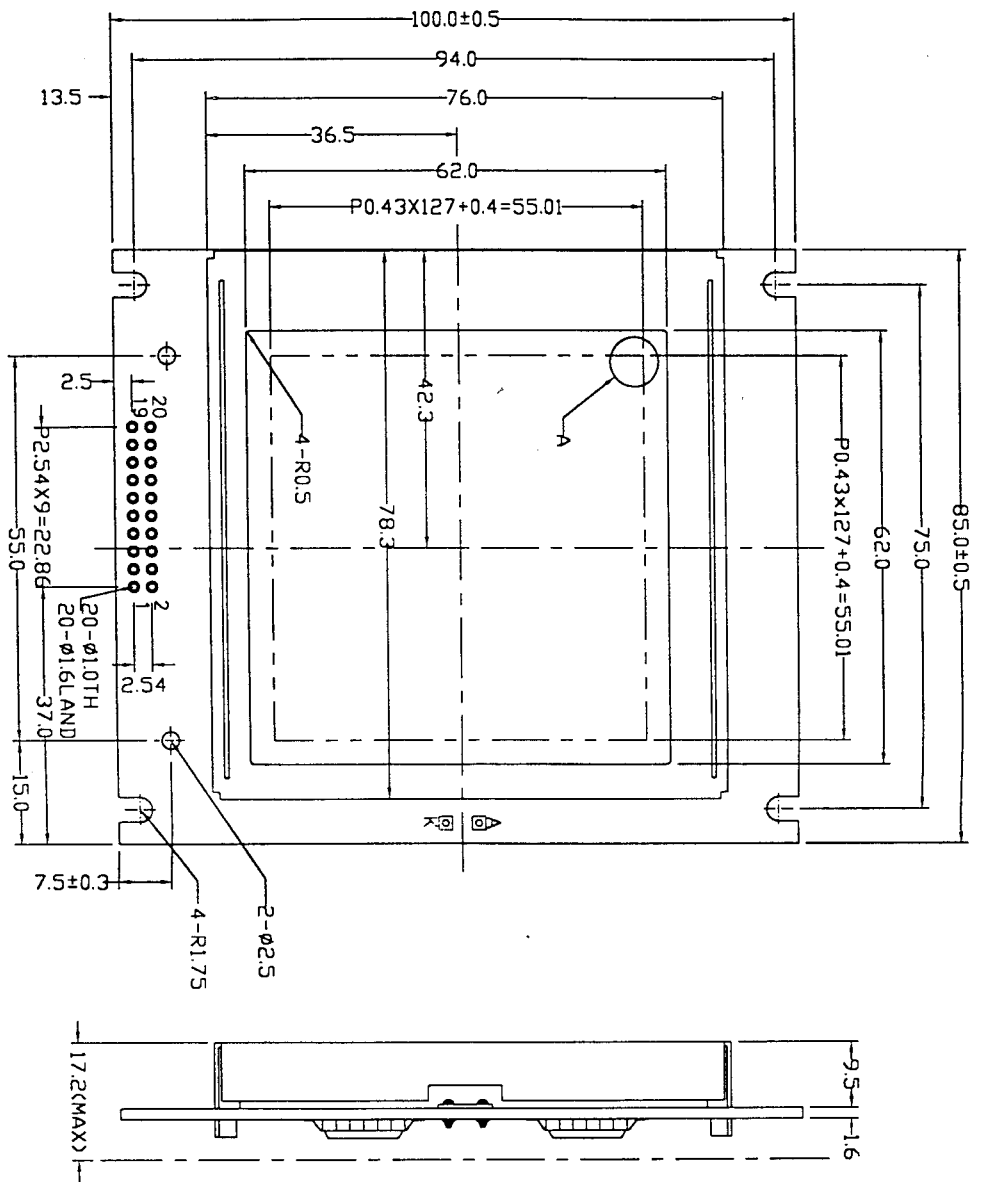

1	FG	11	D0
2	VSS	12	D1
3	VCC	13	D2
4	VEE	14	D3
5	WR	15	D4
6	RD	16	D5
7	CE	17	D6
8	C/D	18	D7
9	NC	19	FS
10	RESET	20	NC

DETAIL A:

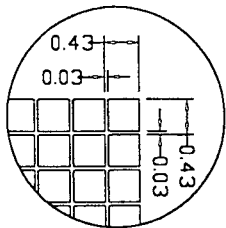

Circuit Block Diagram

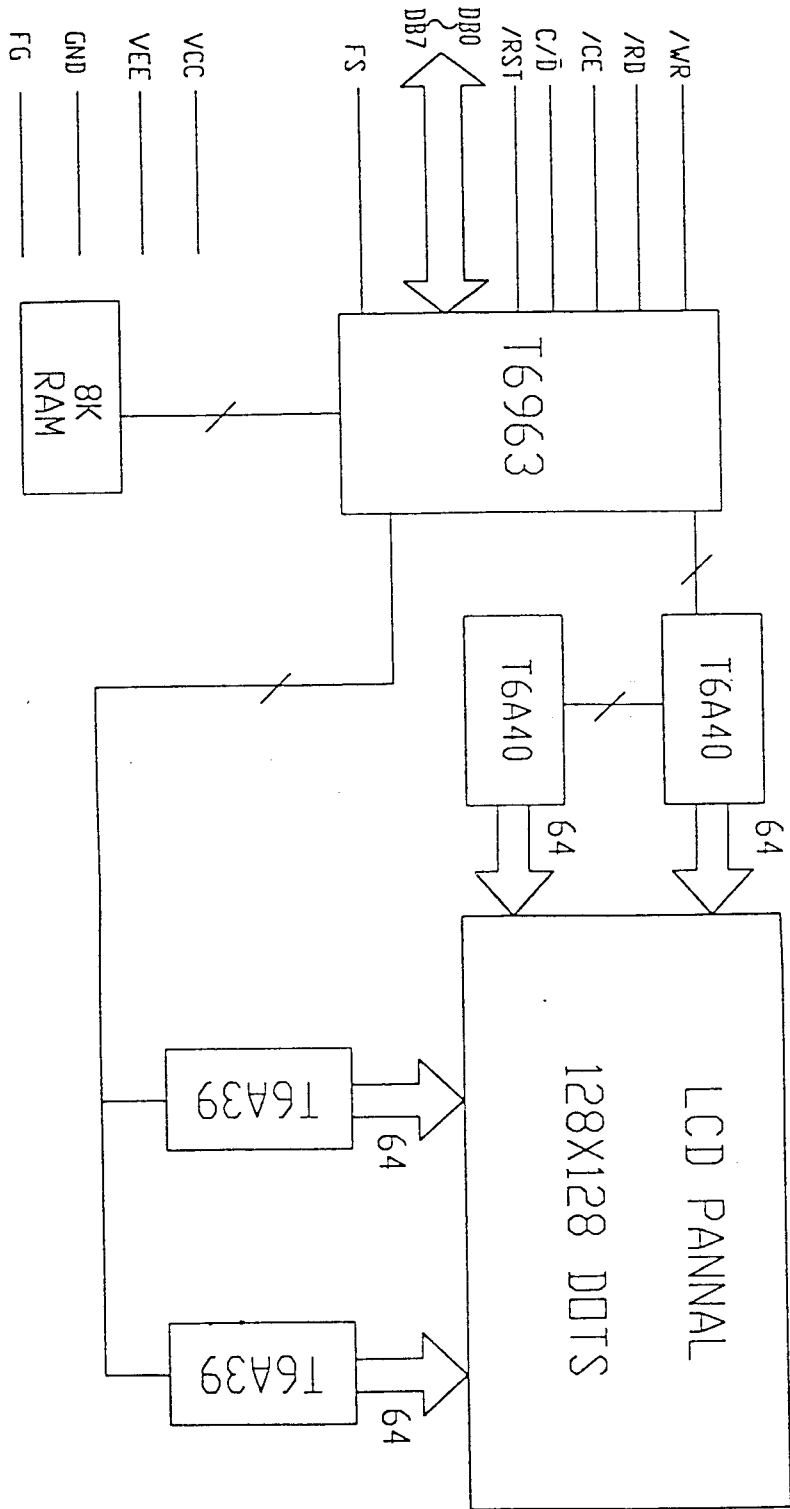

模块部
受控文件

4 Absolute Maximum Ratings

Item	Symbol	Min.	Max.	Unit	Remark
Power Supply Voltage	$V_{DD}-V_{SS}$	-0.3	6.0	V	
LCD Driving Voltage	$V_{DD}-V_{EE}$	—	25.0		
Operating Temperature Range	T_{OP}	0	+50	°C	No Condensation
Storage Temperature Range	T_{ST}	-20	+60		

5 Electrical Specifications and Instruction Code

5.1 Electrical characteristics

Item	Symbol	Min.	Typ.	Max.	Unit	Remark	
Supply Voltage (Logic)	$V_{DD}-V_{SS}$	4.75	5.0	5.25	V		
Supply Voltage (LCD Drive)	$V_{DD}-V_{EE}$	-	18.0	-	V		
Input Signal Voltage	'H'Level	V_{IH}	$0.8V_{DD}$	-	$V_{DD}+0.3$	V	
	'L'Level	V_{IL}	0	-	$0.2V_{DD}$	V	
Supply current (Logic)	I_{DD}	-	-	8.0	mA		
Supply current (LCD Drive)	I_{EE}	-	-	3.0	mA		
Supply current (LED)	I_{LED}	-	-	469.3	mA		

5.2 Interface Signals

Pin No.	Symbol	Level	Description
1	FG	0V	Module Frame Ground
2	VSS	0V	Ground
3	VCC	5.0V	Power supply voltage for logic (+5V)
4	VEE	-13.0V	Power supply voltage for LCD
5	$\overline{\text{WR}}$	H/L	Write Enable Signal
6	$\overline{\text{RD}}$	H/L	Read Enable Signal
7	$\overline{\text{CE}}$	H/L	Chip Enable Signal
8	C/ $\overline{\text{D}}$	H/L	Command/Data Signal
9	NC		
10	$\overline{\text{RESET}}$	H/L	Reset Signal
11	D0	H/L	Data bit0
12	D1	H/L	Data bit1
13	D2	H/L	Data bit2
14	D3	H/L	Data bit3
15	D4	H/L	Data bit4
16	D5	H/L	Data bit5
17	D6	H/L	Data bit6
18	D7	H/L	Data bit7
19	FS	H/L	Font Selection
20	NC		

模块部
受控文件

5.3 Interface Timing Chart:

Bus Timing

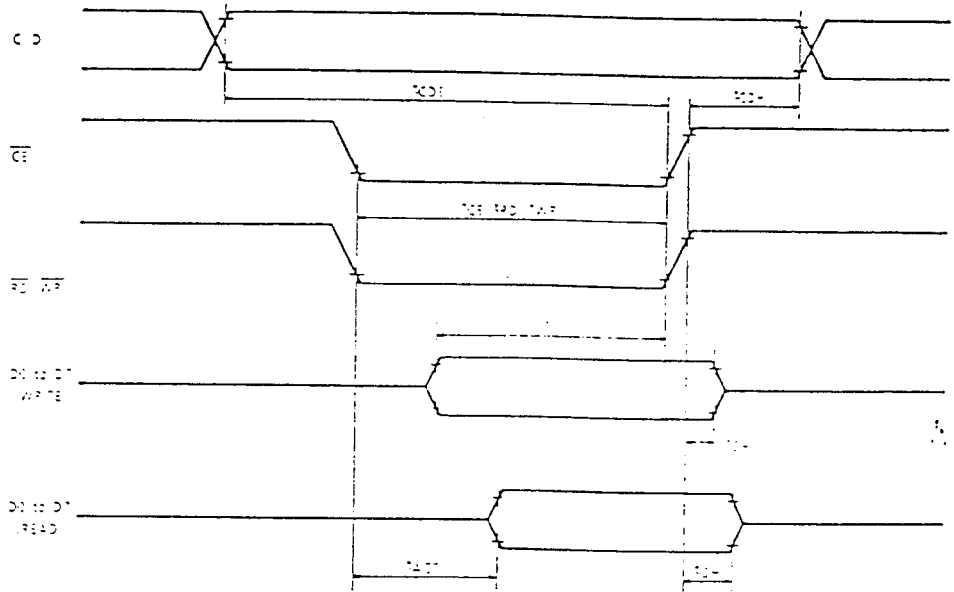

TEST CONDITIONS (Unless otherwise noted, $V_{DD} = 5.0 \pm 10\%$, $V_{SS} = 0V$, $T_a = -20$ to $75^\circ C$)

ITEM	SYMBOL	TEST CONDITIONS	MIN	MAX	UNIT
C/D Set-up Time	t_{COS}	—	100	—	ns
C/D Hold Time	t_{CDH}	—	10	—	ns
CE, RD, WR Pulse Width	t_{CE} , t_{RD} , t_{WR}	—	80	—	ns
Data Set-up Time	t_{DS}	—	80	—	ns
Data Hold Time	t_{DH}	—	40	—	ns
Access Time	t_{ACC}	—	—	150	ns
Output Hold Time	t_{OH}	—	10	50	ns

模块部
受控文件

5.4 Instruction Code

COMMAND DEFINITIONS

COMMAND	CODE	D1	D2	FUNCTION
REGISTERS SETTING	00100001	X address	Y address	Set Cursor Pointer
	00100010	Data	00H	Set Offset Register
	00100100	Low address	High address	Set Address Pointer
SET CONTROL WORD	01000000	Low address	High address	Set Text Home Address
	01000001	Columns	00H	Set Text Area
	01000010	Low address	High address	Set Graphic Home Address
	01000011	Columns	00H	Set Graphic Area
MODE SET	1000X000	—	—	OR mode
	1000X001	—	—	EXOR mode
	1000X011	—	—	AND mode
	1000X100	—	—	Text Attribute mode
	1000XXXX	—	—	Internal CG ROM mode
	10001XXX	—	—	External CG RAM mode
DISPLAY MODE	10010000	—	—	Display off
	1001XX10	—	—	Cursor on, blink off
	1001XX11	—	—	Cursor on, blink on
	100101XX	—	—	Text on, graphic off
	100110XX	—	—	Text off, graphic on
CURSOR PATTERN SELECT	10100000	—	—	1-line cursor
	10100001	—	—	2-line cursor
	10100010	—	—	3-line cursor
	10100011	—	—	4-line cursor
	10100100	—	—	5-line cursor
	10100101	—	—	6-line cursor
	10100110	—	—	7-line cursor
	10100111	—	—	8-line cursor
DATA AUTO READ/ WRITE	10110000	—	—	Set Data Auto Write
	10110001	—	—	Set Data Auto Read
	10110010	—	—	Auto Reset
DATA READ/WRITE	11000000	Data	—	Data Write and Increment ADP
	11000001	—	—	Data Read and Increment ADP
	11000010	Data	—	Data Write and Decrement ADP
	11000011	—	—	Data Read and Decrement ADP
	11000100	Data	—	Data Write and Nonvariable ADP
	11000101	—	—	Data Read and Nonvariable ADP
SCREEN PEEK	11100000	—	—	Screen Peek
SCREEN COPY	11101000	—	—	Screen Copy

X : invalid

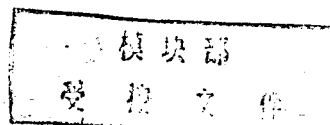

3.5 Character Code Map

ROM CODE 1111

LINE	1	2	3	4	5	6	7	8	9	A	B	C	D	E	F	
1	0	1	2	3	4	5	6	7	8	9	A	B	C	D	E	F
2	0	1	2	3	4	5	6	7	8	9	A	B	C	D	E	F
3	0	1	2	3	4	5	6	7	8	9	A	B	C	D	E	F
4	0	1	2	3	4	5	6	7	8	9	A	B	C	D	E	F
5	0	1	2	3	4	5	6	7	8	9	A	B	C	D	E	F
6	0	1	2	3	4	5	6	7	8	9	A	B	C	D	E	F
7	0	1	2	3	4	5	6	7	8	9	A	B	C	D	E	F

模块部
受控文件

6. Optical Characteristics

6.1 Optical Characteristics

Top=25°C

Item		Symbol	Condition	Min.	Typ.	Max.	Unit	Remark
Viewing Angle	θ_x	$Cr \geq 2$	$\theta_y = 0^\circ$	-30~30			Deg	
	θ_y		$\theta_x = 0^\circ$	-30~20				
Contrast Ratio		Cr	$\theta_x = 0^\circ$ $\theta_y = 0^\circ$	3.0				
Response Time	Turn on	T_{on}	$\theta_x = 0^\circ$ $\theta_y = 0^\circ$			300	ms	
	Turn off	T_{off}				300		

模塊部
受 控 文 件

6.2 Definition of optical characteristics

6.2.1 Definition of viewing Angle(see fig. as follow)

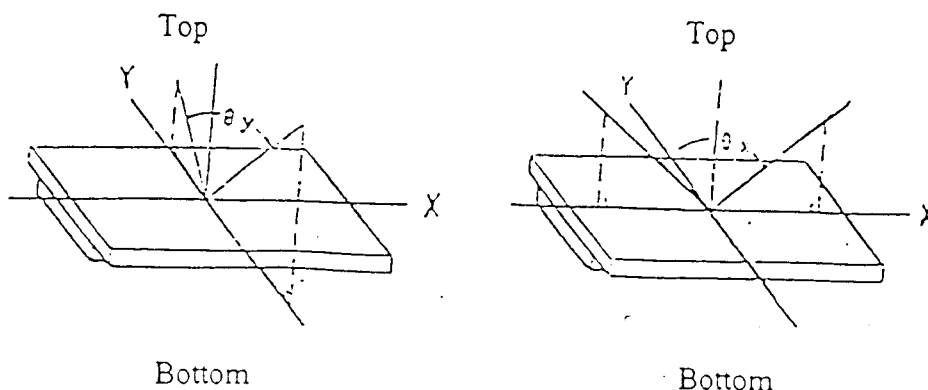

6.2.2 Definition of Contrast Ratio(see fig. as follow)

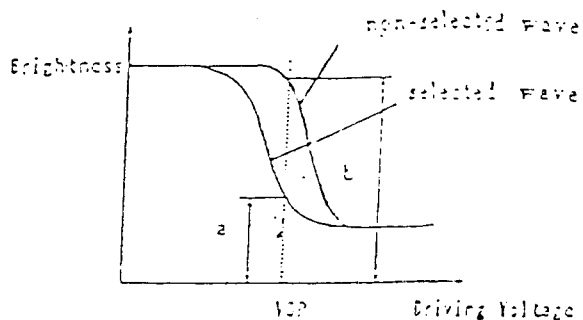

$$\text{Contrast Ratio} = b / a = \frac{\text{non-selected state brightness}}{\text{selected state brightness}}$$

Measuring Conditions:

- 1) Ambient Temperature: 25°C ;
- 2) Frame frequency: 64Hz

6.2.3 Definition of Response time(see fig. as follow)

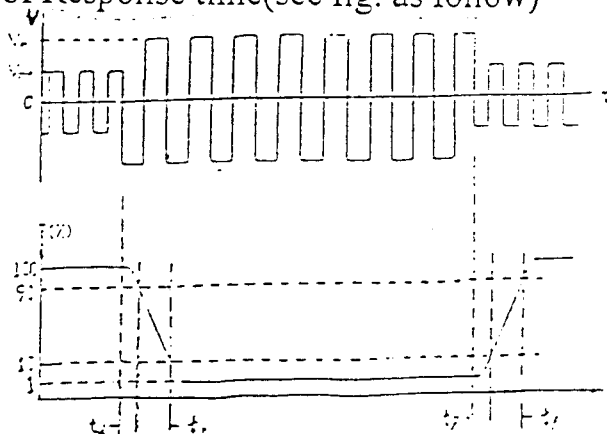

Turn-on time: $t_{on} = t_d + t_r$

Turn-off time: $t_{off} = t_d + t_r$

Measuring Condition:

- 1) Operating Voltage: 18.0V ;
- 2) Frame frequency: 64Hz

模塊部
受控文件

7. Reliability

7.1 Content of Reliability Test

($T_{OP}=25^{\circ}C$)

No.	Test Item	Content of Test	Test condition
1	High Temperature Storage	Endurance test applying the high storage temperature for a long time	60°C 96H
2	Low Temperature Storage	Endurance test applying the low storage temperature for a long time	-20°C 96H
3	High Temperature Operation	Endurance test applying the electric stress (voltage & current) and the thermal stress to the element for a long time	50°C 96H
4	Low Temperature Operation	Endurance test applying the electric stress under low temperature for a long time	0°C 96H
5	High Temperature /Humidity Storage	Endurance test applying the high temperature and high humidity storage for a long time	40°C 90%RH 96H
6	Temperature Cycle	Endurance test applying the low and high temperature cycle $ \begin{array}{ccccccc} -20^{\circ}C & \longleftrightarrow & 25^{\circ}C & \longleftrightarrow & 60^{\circ}C & \longleftrightarrow & 25^{\circ}C \\ 30min & & 5min & & 30min & & 5min \\ \longleftarrow & & & & & & \longrightarrow \\ & & & & & & \text{1 cycle} \end{array} $	-20°C~60°C 10 cycles
7	Vibration Test (package state)	Endurance test applying the vibration during transportation	10Hz~150Hz, 50m/s ² , 40min
8	Shock Test (package state)	Endurance test applying the shock during transportation	Half-sinewave, 100m/s ² , 11ms
9	Atmospheric Pressure Test	Endurance test applying the atmospheric pressure during transportation by air	40kPa 16H

製造部
受控文書

7.2 Failure Judgment Criterion

Criterion Item	Test Item No.									Failure Judgement Criterion
	1	2	3	4	5	6	7	8	9	
Basic Specification	0	0	0	0	0	0	0	0	0	Out of the basic Specification
Electrical specification	0	0	0	0	0					Out of the electrical specification
Mechanical Specification							0	0		Out of the mechanical specification
Optical Characteristic	0	0	0	0	0	0			0	Out of the optical specification
Remark	Basic specification = Optical specification + Mechanical specification									

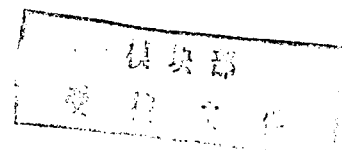

8 Precautions for use of LCD Modules

8.1 Handling Precautions

- 8.1.1 The display panel is made of glass. Do not subject it to a mechanical shock by dropping it from a high place, etc.
- 8.1.2 If the display panel is damaged and the liquid crystal substance inside it leaks out, be sure not to get any in your mouth, if the substance comes into contact with your skin or clothes, promptly wash it off using soap and water.
- 8.1.3 Do not apply excessive force to the display surface or the adjoining areas since this may cause the color tone to vary.
- 8.1.4 The polarizer covering the display surface of the LCD module is soft and easily scratched. Handle this polarizer carefully.
- 8.1.5 If the display surface is contaminated, breathe on the surface and gently wipe it with a soft dry cloth. If still not completely clear, moisten cloth with one of the following solvents:
- Isopropyl alcohol
 - Ethyl alcohol
- Solvents other than those mentioned above may damage the polarizer. Especially, do not use the following:
- Water
 - Ketone
 - Aromatic solvents
- 8.1.6 Do not attempt to disassemble the LCD Module.
- 8.1.7 If the logic circuit power is off, do not apply the input signals.
- 8.1.8 To prevent destruction of the elements by static electricity, be careful to maintain an optimum work environment.
- a. Be sure to ground the body when handling the LCD Modules.
 - b. Tools required for assembly, such as soldering irons, must be properly ground.
 - c. To reduce the amount of static electricity generated, do not conduct assembly and other work under dry conditions.
 - d. The LCD Module is coated with a film to protect the display surface. Be care when peeling off this protective film since static electricity may be generated.

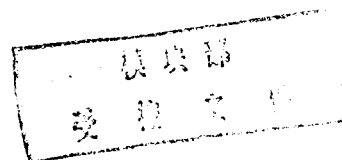

8.2 Storage precautions

8.2.1 When storing the LCD modules, avoid exposure to direct sunlight or to the light of fluorescent lamps.

8.2.2 The LCD modules should be stored under the storage temperature range. If the LCD modules will be stored for a long time, the recommend condition is:

temperature : $0^{\circ}\text{C} \sim 40^{\circ}\text{C}$

relatively humidity: $\leq 80\%$

8.2.3 The LCD modules should be stored in the room without acid, alkali and harmful gas.

8.3 The LCD modules should be no falling and violent shocking during transportation, and also should avoid excessive press, water, damp and sunshine.

