

SPECIFICATION FOR LCD MODULE

Model No. TM160240ACAWG1

Prepared by:	Date:
Checked by :	Date:
Verified by :	Date:
Approved by:	Date:

TIANMA MICROELECTRONICS CO., LTD

REVISION RECORD

Date	Ver.	Ref. Page	Revision No.	Revision Item

1. General Specifications:

- 1.1 Display type: FSTN
- 1.2 Display color*¹:
 - Display color: Blue-black
 - Background: White
- 1.3 Polarizer mode: Reflective/Positive
- 1.4 Viewing Angle: 6:00
- 1.5 Driving Method: 1/240 Duty 1/13 Bias
- 1.6 Lcd operating voltage: 21.5V
- 1.7 Backlight: None
- 1.8 Driver: S6B0794X01-B0CZ + S6B0796X01-B0CZ
- 1.9 Data Transfer: 4 Bit Parallel
- 1.10 Operating Temperature: -20----+70°C
 - Storage Temperature: -30----+80°C
- 1.11 Outline Dimensions: Refer to outline drawing on next page
- 1.12 Dot Matrix: 160 X 240Dots
- 1.13 Dot Size: 0.22X0.22 (mm)
- 1.14 Dot Pitch: 0.24X0.24 (mm)
- 1.15 Weight: Approx 150g

*¹ Color tone is slightly changed by temperature and driving voltage.

TOP VIEW

BACK VIEW

1/0 P008

NO.	1	2	3	4	5	6	7	8	9	10	11	12	13	14	15	16	17	18	19	20	21	22
-----	---	---	---	---	---	---	---	---	---	----	----	----	----	----	----	----	----	----	----	----	----	----

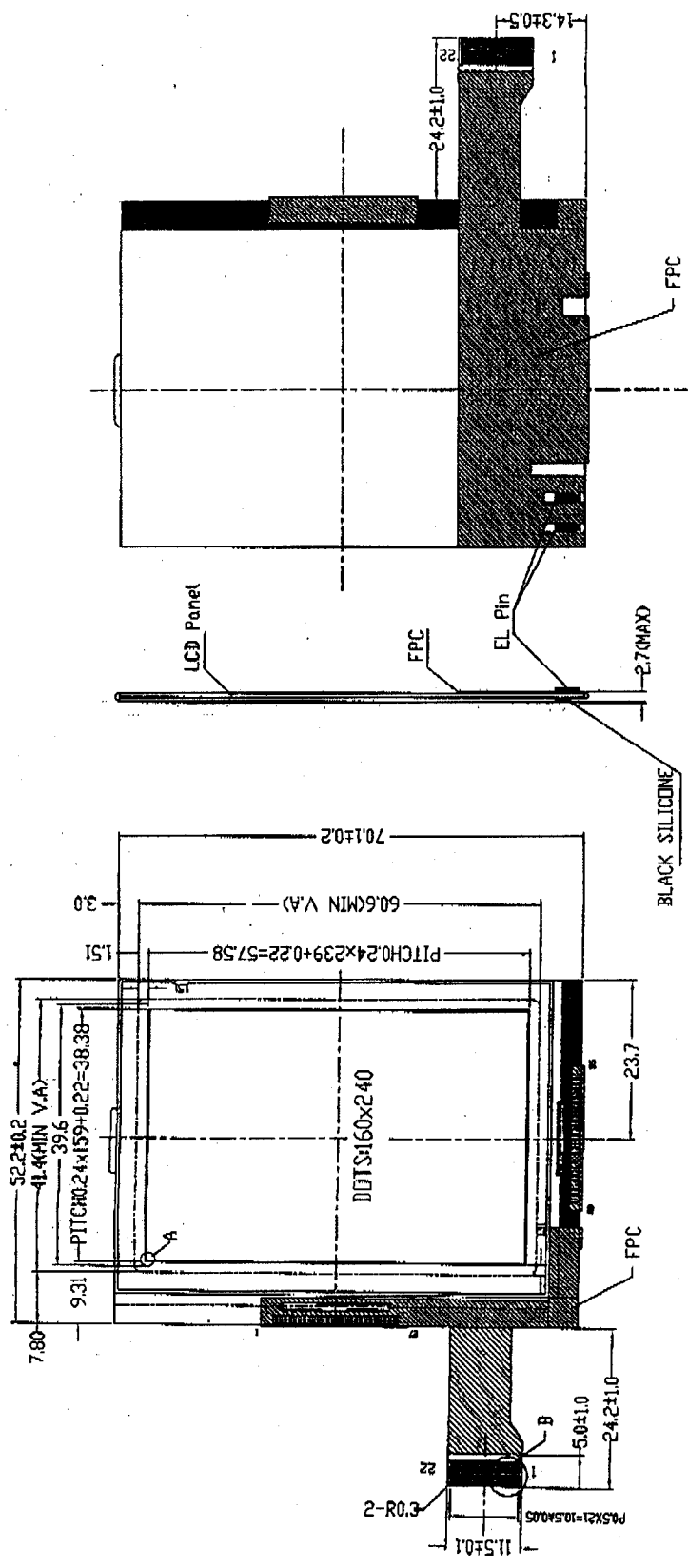

DETAIL B:

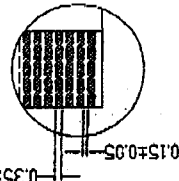

DETAIL A:

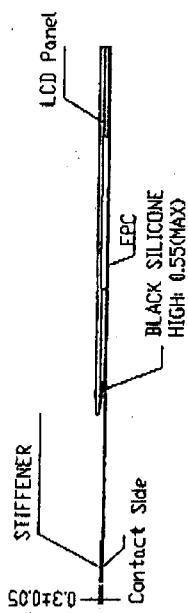
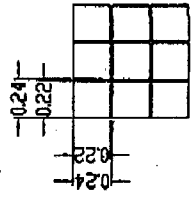

NOTES:

1. DISPLAY TYPE: FSTN
2. VIEWING DIRECTION: 6:00
3. POLARIZER MODE: REFLECTIVE/POSITIVE
4. DRIVE METHOD: 1/240 DUTY 1/13 BIAS
5. LCD OPERATING VOLTAGE: 21.5V VDD=2.4~5.5V
6. OPERATING TEMP: -20°C~+70°C
7. STORAGE TEMP: -30°C~+80°C
8. CONNECTOR: FPC
9. DRIVER: S6B0794X01-B0CZ + S6B0796X01-B0CZ
10. WITHOUT BACKLIGHT
11. UNMARKED TOLERANCES: ±0.3mm

TIAN-MA MICROELECTRONICS CO
 6/F., CASTIC Building, Sherman Road, Central, Shenzhen, PR

DRAWN BY:	Y. D. [Signature]	TITLE:	TM160240ACAVG1
CHECKED BY:	[Signature]	DATE:	
APPROVED BY:	[Signature]	FIG. NO.:	G-1
CONTROLLED BY:	[Signature]	FIG. NAME:	TM160240ACAVG1-SHEZ 10 C

3. LCD Module Part Numbering System

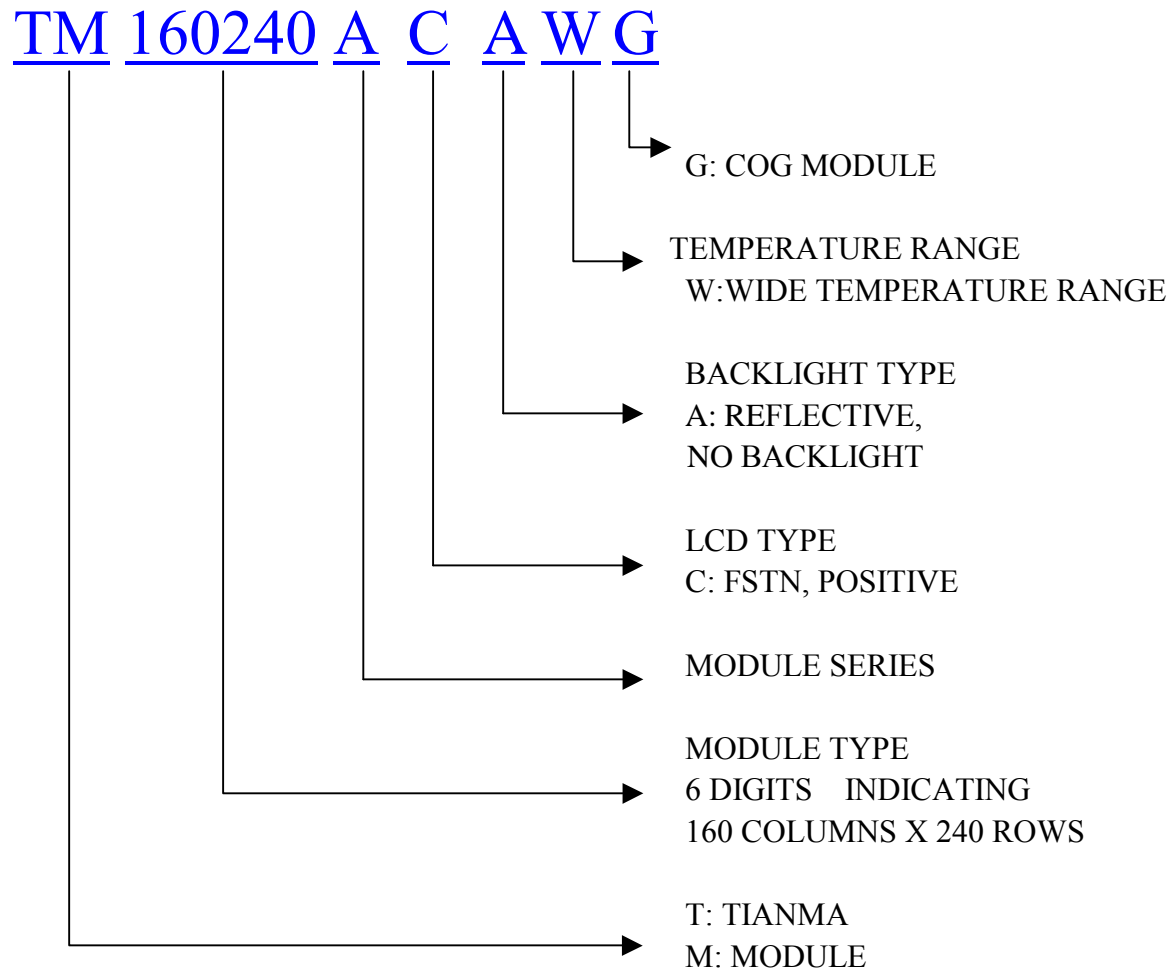

4. Circuit Block Diagram

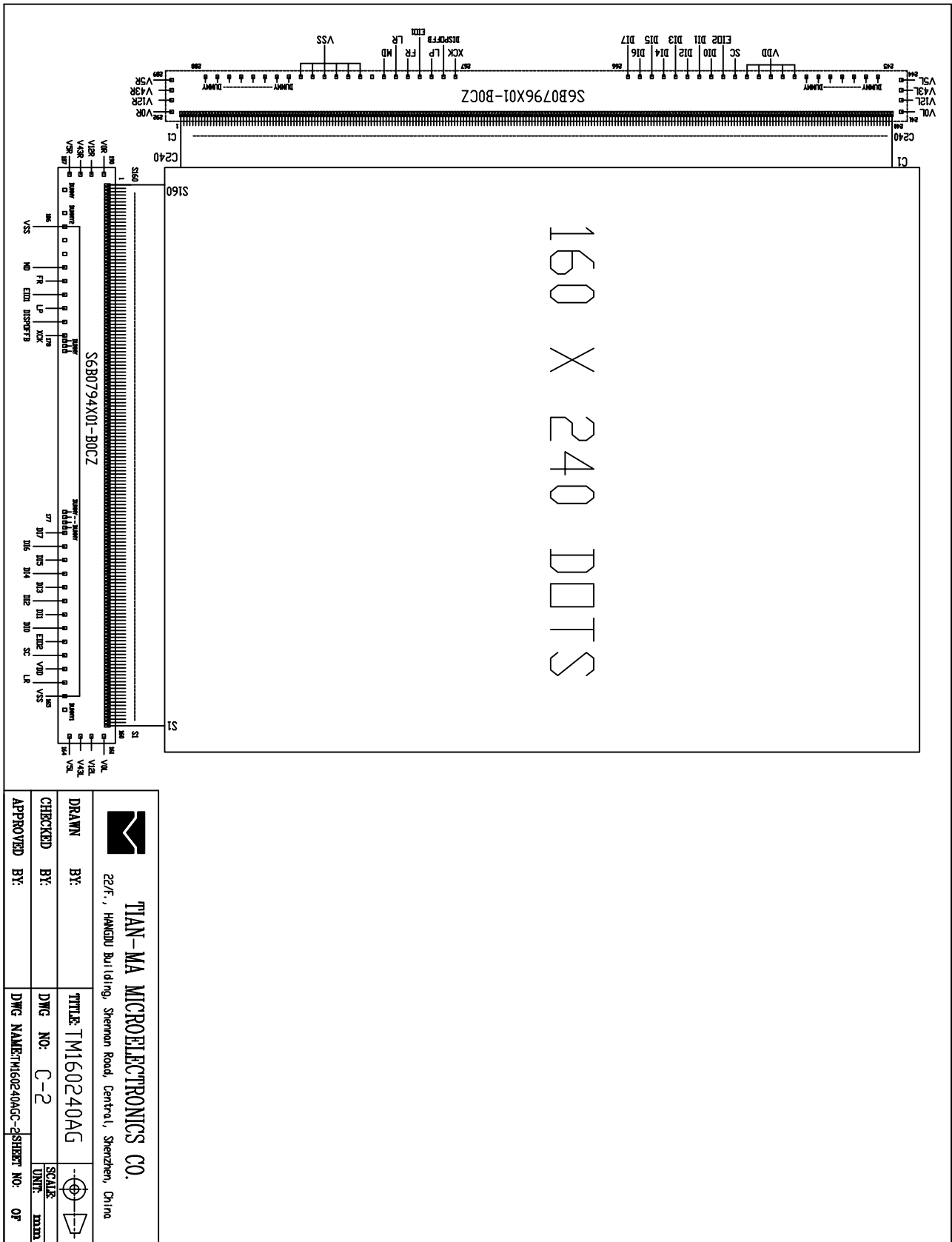

TIAN-MA MICROELECTRONICS CO.
 22/F., HANGOU Building, Shennan Road, Central, Shenzhen, China

DRAWN BY:	TM160240AG	SCALE:	1:1
CHECKED BY:	C-2	UNIT:	mm
APPROVED BY:	DWG NAME: TM160240AG-C-2 SHEET NO:	OP	

5. Absolute Maximum Ratings

Item	Symbol	Min.	Max.	Unit	Remark
Power Supply Voltage	$V_{DD}-V_{SS}$	-0.3	6.0	V	
LCD Driving Voltage	V_{LCD}	-	28.0		
Operating Temperature Range	T_{OP}	-20	+70	°C	No Condensation
Storage Temperature Range	T_{ST}	-30	+80		

6. Electrical Specifications and Instruction Code

6.1 Electrical characteristics

Item		Symbol	Min.	Typ.	Max.	Unit
Supply Voltage (Logic)		$V_{DD}-V_{SS}$	4.75	5.0	5.25	V
Supply Voltage (LCD Drive)		V_{LCD}	-	21.5	-	V
Input Signal Voltage	High	V_{IH} ($V_{DD}=5.0$)	$0.8V_{DD}$	-	$V_{DD}+0.3$	V
	Low	V_{IL} ($V_{DD}=5.0$)	0	-	$0.2V_{DD}$	V
Supply current (Logic)		I_{DD} ($V_{DD}-V_{SS}=5.0V$)	-	-	0.5	mA
Supply current (LCD Drive)		I_{EE}	-	-	0.7	mA

6.2 Interface Signals

Pin No.	Symbol	Level	Description
1	V5	-	Bias Voltage For Non-Select (Common Driver)
2	V2	-	Bias Voltage For Non-Select(Common Driver)
3	VEE	21.5V	Power Supply For LCD
4	VDD	5.0V	Power Supply For LOGIC
5	FRM	H/L	Frame Start Signal
6	VGND	0V	GROUND
7	LOAD	H/L	Latch Pulse of Display Data
8	VSS	0V	GROUND
9	DF	H/L	Switch Signal to Convert LCD Driver
10	D/OFF	H/L	H: Display On L: Display Off
11	CP	H/L	Clock Pules for Segment Shift Register
12	V4	-	Bias Voltage For Non-Select(Segment Driver)
13	V3	-	Bias Voltage For Non-Select(Segment Driver)
14	D3	H/L	Input Data Signal
15	D2	H/L	Input Data Signal
16	D1	H/L	Input Data Signal
17	D0	H/L	Input Data Signal
18	VGND	0V	GROUND
19	VSS	0V	GROUND
20	NC	-	No connection
21	VSS	0V	GROUND
22	NC	-	No connection

6.3 Interface Timing Chart

8080 family interface timing

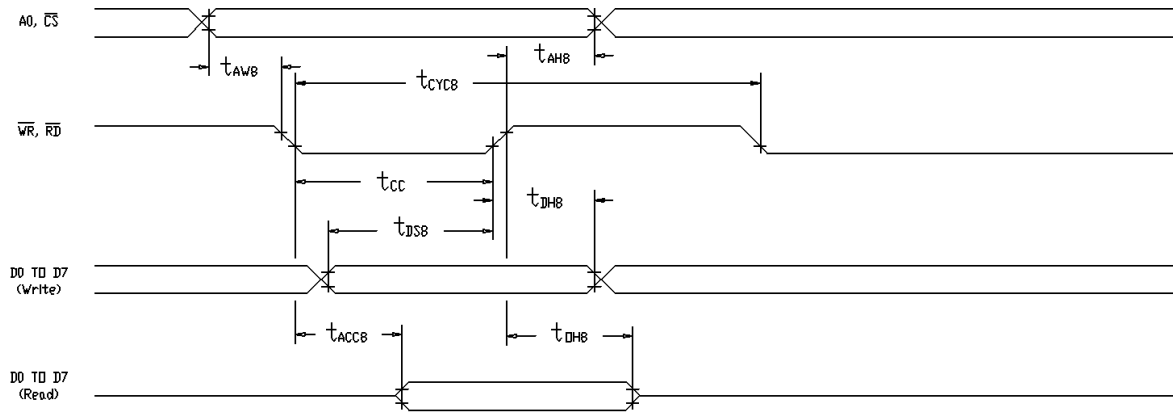

Ta=-20 to 75 deg. C

Signal	Symbol	Parameter	V _{DD} =4.5 to 5.5V		V _{DD} =2.7 to 5.5V		Unit	Condition
			min	max	min	max		
A0, \overline{CS}	t_{AH8}	Address hold time	10	-	10	-	ns	CL=100pF
	t_{AW8}	Address setup time	0	-	0	-	ns	
$\overline{WR}, \overline{RD}$	t_{CYC8}	System cycle time	See note.	-	See note.	-	ns	
	t_{CC}	Strobe pulsewidth	120	-	150	-	ns	
D0 to D7	t_{DS8}	Data setup time	120	-	120	-	ns	
	t_{DH8}	Data hold time	5	-	5	-	ns	
	t_{ACC8}	\overline{RD} access time	-	50	-	80	ns	
	t_{OH8}	Output disable time	10	50	10	55	ns	

Note

For memory control and system control commands:

$$t_{CYC8} = 2 t_c + t_{CC} + t_{CEA} + 75 > t_{ACV} + 245$$

for all other commands:

$$t_{CYC8} = 4 t_c + t_{CC} + 30$$

6800 family interface timing

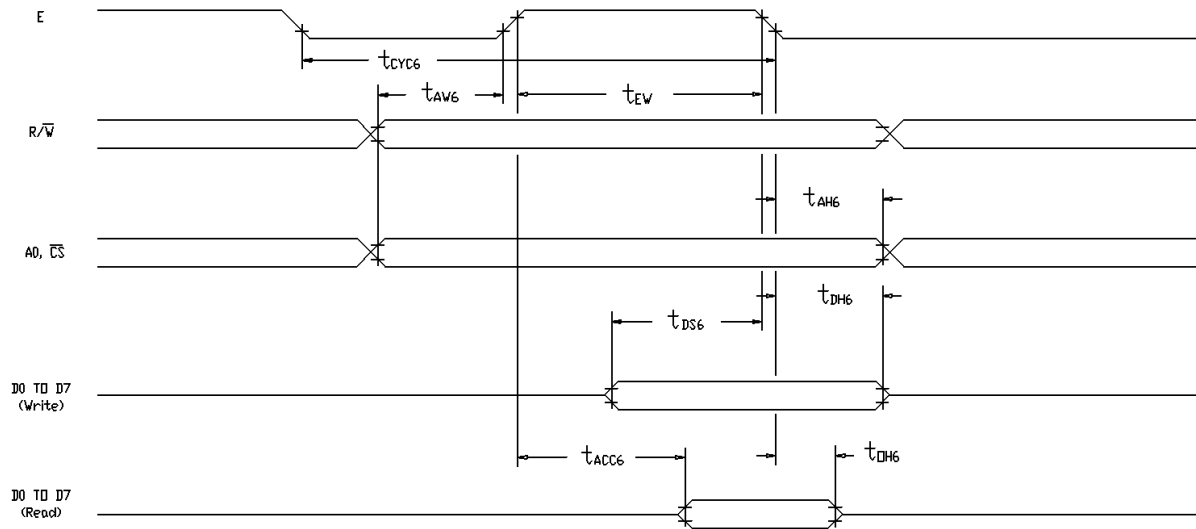

Note

t_{CYC6} indicates the interval during which CS is LOW and E is HIGH

Ta=-20 to 75 deg. C

Signal	Symbol	Parameter	$V_{DD}=4.5$ to $5.5V$		$V_{DD}=2.7$ to $5.5V$		Unit	Condition
			min	Max	min	max		
A0, \overline{CS}	t_{CYC6}	System cycle time	See note.	-	See note.	-	ns	CL=100pF
	t_{AW6}	Address setup time	0	-	10	-	ns	
$\overline{R/W}$	t_{AH6}	Address hold time	0	-	0	-	ns	
D0 to D7	t_{DS6}	Data setup time	100	-	120	-	ns	
	t_{DH6}	Data hold time	0	-	0	-	ns	
	t_{OH6}	Output disable time	10	50	10	75	ns	
	t_{ACC6}	Access time	-	85	-	130	ns	
E	t_{EW}	Enable pulsewidth	120	-	150	-	ns	

Note

For memory control and system control commands:

$$t_{CYC8} = 2 t_C + t_{CC} + t_{CEA} + 75 > t_{ACV} + 245$$

for all other commands:

$$t_{CYC8} = 4 t_C + t_{EW} + 30$$

6.4 Instruction Code (Controller: SED1335F)

Class	Command	Code											Command description	Number of Bytes	
		RD	WR	A0	D7	D6	D5	D4	D3	D2	D1	D0			
System control	SYSTEM SET	1	0	1	0	1	0	0	0	0	0	0	0	Initialize device and display	8
	SLEEP IN	1	0	1	0	1	0	1	0	0	1	1	0	Enter standby mode	0
Display control	DISP ON/OFF	1	0	1	0	1	0	1	1	0	0	D	Enable and disable display and display flashing	1	
	SCROLL	1	0	1	0	1	0	0	0	1	0	0	Set display start address and display regions	10	
	CSRFORM	1	0	1	0	1	0	1	1	1	0	1	Set cursor type	2	
	CGRAM ADR	1	0	1	0	1	0	1	1	1	0	0	Set start address of character generator RAM	2	
	CSRDIR	1	0	1	0	1	0	0	1	1	CD	CD	Set direction of cursor movement	0	
	HDOT SCR	1	0	1	0	1	0	1	1	0	1	0	Set horizontal scroll position	1	
	OVLAY	1	0	1	0	1	0	1	1	0	1	1	Set display overlay format	1	
Drawing control	CSRW	1	0	1	0	1	0	0	0	1	1	0	Set cursor address	2	
	CSRR	0	1	1	0	1	0	0	0	1	1	1	Read cursor address	2	
Memory control	MWRITE	1	0	1	0	1	0	0	0	0	1	0	Write to display memory	-	
	MREAD	0	1	1	0	1	0	0	0	0	1	1	Read from display memory	-	

Notes

- In general, the internal registers of the SED1335F/1336F are modified as each command parameter is input. However, the microprocessor does not have to set all the parameters of a command and may send a new command before all parameters have been input. The internal registers for the parameters that have been input will have been changed but the remaining parameter registers are unchanged.
2-byte parameters (where two bytes are treated as 1 data item) are handled as follows:
 - CSRW, CSRR: Each byte is processed individually. The microprocessor may read or write just the low byte of the cursor address.
 - SYSTEM SET, SCROLL, CGRAM ADR: Both parameter bytes are processed together. If the command is changed after half of the parameters has been input, the single byte is ignored.
- APL and APH are 2-byte parameters, but are treated as two 1-byte parameters.

7. Optical Characteristics

7.1 Optical Characteristics

Ta=25°C

Item	Symbol	Condition	Min.	Typ.	Max.	Unit	
Viewing Angle	θ_x	$C_r \geq 2$	$\theta_y = 0^\circ$	-30	--	20	Deg
	θ_y			$\theta_x = 0^\circ$	-30	--	
Contrast Ratio	C_r	$\theta_x = 0^\circ$ $\theta_y = 0^\circ$	3.0		-	-	
Response Time	Turn on	T_{on}	$\theta_x = 0^\circ$ $\theta_y = 0^\circ$	-	-	350	Ms
	Turn off	T_{off}		-	-	350	

7.2 Definition of Optical Characteristics

7.2.1 Definition of Viewing Angle

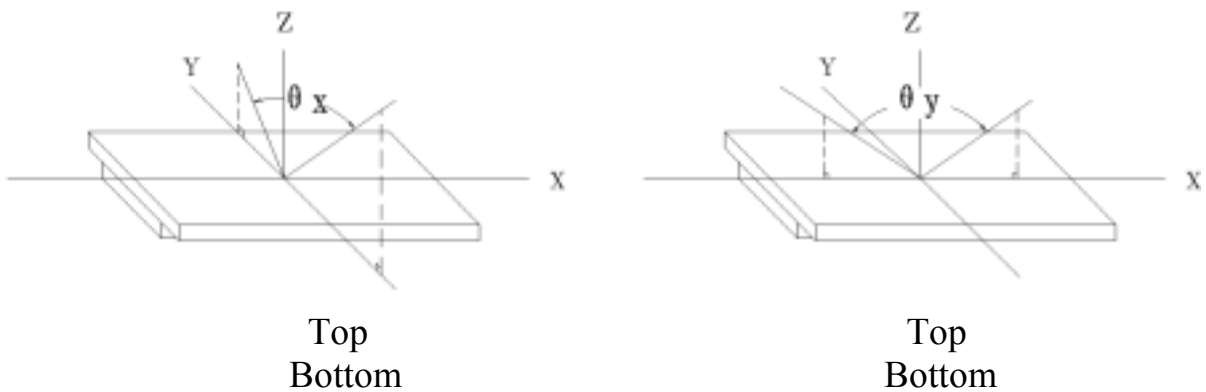

7.2.2 Definition of Contrast Ratio

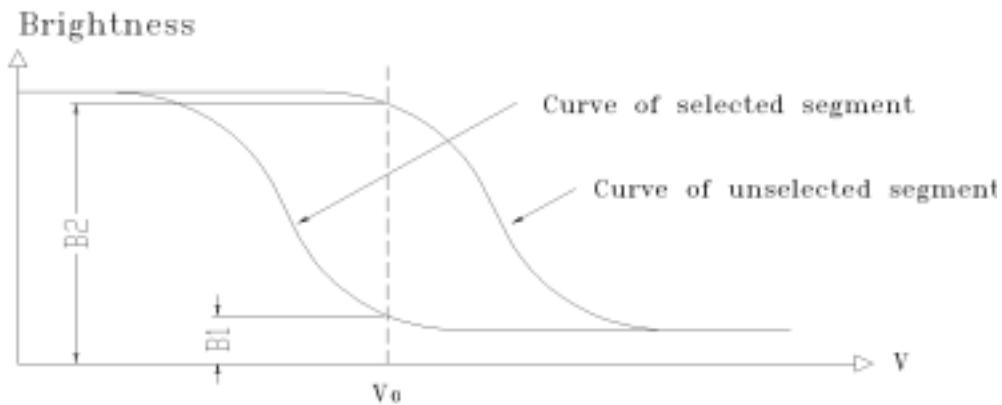

$$\text{Contrast Ratio} = B2/B1 = \frac{\text{unselected state brightness}}{\text{selected state brightness}}$$

Measuring Conditions:

- 1) Ambient Temperature: 25°C ;
- 2) Frame frequency: 64Hz

7.2.3 Definition of Response time

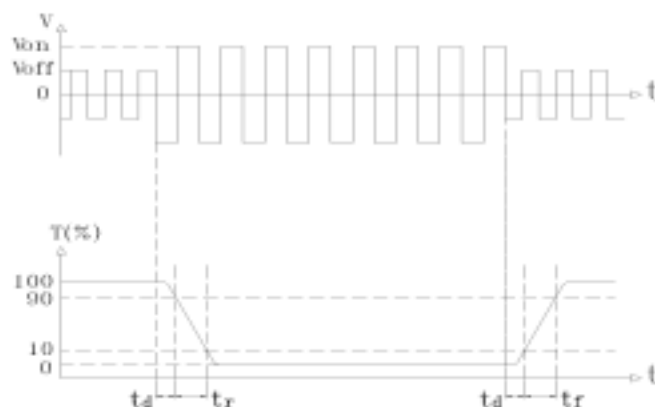

Turn on time: $t_{on} = t_d + t_r$ Turn off time: $t_{off} = t_d + t_r$

Measuring Condition:

- 1) Operating Voltage: 21.5V ;
- 2) Frame frequency: 64Hz

8. Reliability

8.1 Content of Reliability Test

Ta=25°C

No.	Test Item	Content of Test	Test condition
1	High Temperature Storage	Endurance test applying the high storage temperature for a long time	80°C 240H Restore 4H at 25°C
2	Low Temperature Storage	Endurance test applying the low storage temperature for a long time	-30°C 240H Restore 4H at 25°C
3	High Temperature Operation	Endurance test applying the electric stress (voltage & current) and the thermal stress to the element for a long time	70°C 240H
4	Low Temperature Operation	Endurance test applying the electric stress under low temperature for a long time	-20°C 240H
5	High Temperature /Humidity Storage	Endurance test applying the high temperature and high humidity storage for a long time	60°C 95%RH 240H Restore 4H at 25°C
6	Temperature Cycle	Endurance test applying the low and high temperature cycle $-30^{\circ}\text{C} \longleftrightarrow_{30\text{min}} 25^{\circ}\text{C} \longleftrightarrow_{5\text{min}} 80^{\circ}\text{C} \longleftrightarrow_{30\text{min}} 25^{\circ}\text{C} \longleftrightarrow_{5\text{min}} \leftarrow$ 1 cycle	-30°C/80°C 10 cycles Restore 4H at 25°C
7	Vibration Test (package state)	Endurance test applying the vibration during transportation	10Hz~500Hz, 100m/s ² , 120min
8	Shock Test (package state)	Endurance test applying the shock during transportation	Half- sine wave, 300m/s ² , 18ms
9	Atmospheric Pressure Test	Endurance test applying the atmospheric pressure during transportation by air	25kPa 16H Restore 2H

8.2 Failure Judgment Criterion

Criterion Item	Test Item No.									Failure Judgement Criterion
	1	2	3	4	5	6	7	8	9	
Basic Specification	√	√	√	√	√	√	√	√	√	Out of the basic Specification
Electrical Specification	√	√	√	√	√					Out of the electrical specification
Mechanical Specification							√	√		Out of the mechanical specification
Optical Characteristic	√	√	√	√	√	√			√	Out of the optical specification
Note	For test item refer to 8.1									
Remark	Basic specification = Optical specification + Mechanical specification									

9. QUALITY LEVEL

Examination or Test	At $T_a=25^{\circ}\text{C}$ (unless otherwise stated)	Inspection				
		Min.	Max.	Unit	IL	AQL
External Visual Inspection	Under normal illumination and eyesight condition, the distance between eyes and LCD is 25cm.	See Appendix A			II	Major 1.0 Minor 2.5
Display Defects	Under normal illumination and eyesight condition, display on inspection.	See Appendix B			II	Major 1.0 Minor 2.5
Note: Major defects: Open segment or common, Short, Serious damages, Leakage Miner defects: Others Sampling standard conforms to GB2828						

10. Precautions for Use of LCD Modules

10.1 Handling Precautions

10.1.1 The display panel is made of glass. Do not subject it to a mechanical shock by dropping it from a high place, etc.

10.1.2 If the display panel is damaged and the liquid crystal substance inside it leaks out, be sure not to get any in your mouth, if the substance comes into contact with your skin or clothes, promptly wash it off using soap and water.

10.1.3 Do not apply excessive force to the display surface or the adjoining areas since this may cause the color tone to vary.

10.1.4 The polarizer covering the display surface of the LCD module is soft and easily scratched. Handle this polarizer carefully.

10.1.5 If the display surface is contaminated, breathe on the surface and gently wipe it with a soft dry cloth. If still not completely clear, moisten cloth with one of the following solvents:

- Isopropyl alcohol
- Ethyl alcohol

Solvents other than those mentioned above may damage the polarizer. Especially, do not use the following:

- Water
- Ketone
- Aromatic solvents

10.1.6 Do not attempt to disassemble the LCD Module.

10.1.7 If the logic circuit power is off, do not apply the input signals.

10.1.8 To prevent destruction of the elements by static electricity, be careful to maintain an optimum work environment.

- a. Be sure to ground the body when handling the LCD Modules.
- b. Tools required for assembly, such as soldering irons, must be properly ground.
- c. To reduce the amount of static electricity generated, do not conduct assembly and other work under dry conditions.
- d. The LCD Module is coated with a film to protect the display surface. Be care when peeling off this protective film since static electricity may be generated.

10.2 Storage precautions

10.2.1 When storing the LCD modules, avoid exposure to direct sunlight or to the light of fluorescent lamps.

10.2.2 The LCD modules should be stored under the storage temperature range. If the LCD modules will be stored for a long time, the recommend condition is:

Temperature : $0^{\circ}\text{C} \sim 40^{\circ}\text{C}$

Relatively humidity: $\leq 80\%$

10.2.3 The LCD modules should be stored in the room without acid, alkali and harmful gas.

10.3 The LCD modules should be no falling and violent shocking during transportation, and also should avoid excessive press, water, damp and sunshine.

Appendix A

Inspection items and criteria for appearance defects

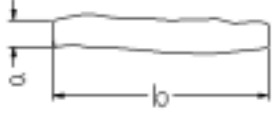
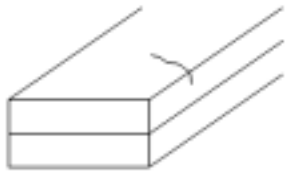
Items	Contents	Criteria			
Leakage		Not permitted			
Rainbow		According to the limit specimen			
Polarizer	Wrong polarizer attachment	Not permitted			
	Bubble between polarizer and glass	Not counted	Max. 3 defects allowed		
		$\phi < 0.3\text{mm}$	$0.3\text{mm} \leq \phi \leq 0.5\text{mm}$		
	Scratches of polarizer	According to the limit specimen			
Black spot (in viewing area)		Not counted	Max. 3 spots allowed	Max. 3 spots (lines) allowed	
		$X < 0.2\text{mm}$	$0.2\text{mm} \leq X \leq 0.5\text{mm}$		
		$X = (a+b)/2$			
Black line (in viewing area)		Not counted	Max. 3 lines allowed		
		$a < 0.02\text{mm}$	$0.02\text{mm} \leq a \leq 0.05\text{mm}$ $b \leq 2.0\text{mm}$		
Progressive cracks		Not permitted			

Appendix A

Inspection item and criteria for appearance defects (continued)

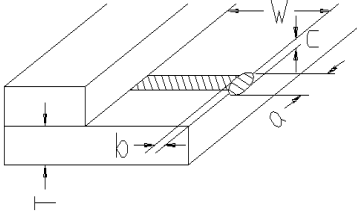
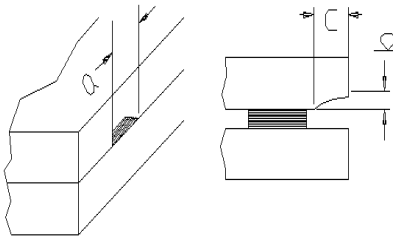
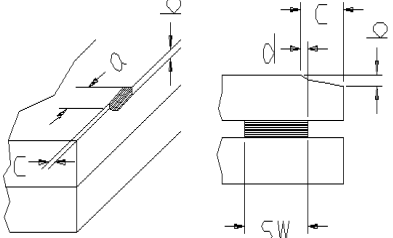
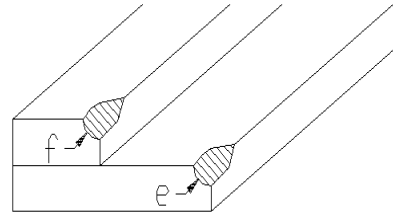
Items	Contents	Criteria				
Glass Cracks	Cracks on pads 	a	b	c	Max. 2 Cracks allowed	Max. 5 cracks allowed
	$\leq 3\text{mm}$	$\leq W/5$	$\leq T/2$			
	$\leq 2\text{mm}$	$\leq W/5$	$T/2 < C < T$			
	Cracks on contact side 	a	b		Max. 2 cracks allowed	
	$\leq 3\text{mm}$	$\leq T/2$				
	$\leq 2\text{mm}$	$T/2 < b < T$				
	C shall be not reach the seal area					
	Cracks on non-contact side 	a	b		Max. 2 cracks allowed	
	$\leq 3\text{mm}$	$\leq T/2$				
	$\leq 2\text{mm}$	$T/2 < b < T$				
$C \leq 0.5\text{mm}$						
$d \leq SW/3$						
Corner cracks 	$e < 2.0\text{mm}^2$ $f < 2.0\text{mm}^2$			Max. 3 cracks allowed		

Appendix B

Inspection items and criteria for display defects

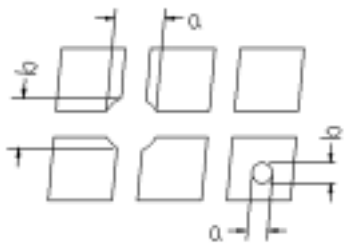
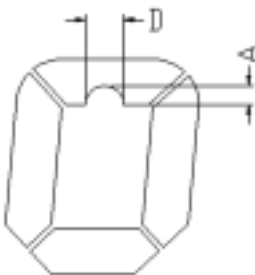
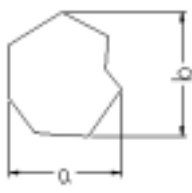
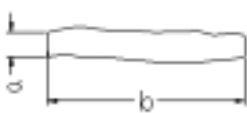
Items	Contents	Criteria			
Open segment or open common		Not permitted			
Short		Not permitted			
Wrong viewing angle		Not permitted			
Contrast ratio uneven		According to the limit specimen			
Crosstalk		According to the limit specimen			
Pin holes and cracks in segment (DOT)		Not counted	Max.3 dots allowed		Max.3 dots allowed
		$X < 0.1\text{mm}$	$0.1\text{mm} \leq X \leq 0.2\text{mm}$		
		$X = (a+b)/2$			
		Not counted	Max.2 dots allowed		
$A < 0.1\text{mm}$		$0.1\text{mm} \leq A \leq 0.2\text{mm}$ $D < 0.25\text{mm}$			
Black spot (in viewing area)		Not counted	Max.3 spots allowed		Max.3 spots (lines) allowed
		$X < 0.1\text{mm}$	$0.1\text{mm} \leq X \leq 0.2\text{mm}$		
		$X = (a+b)/2$			
Black line (in viewing area)		Not counted	Max.3 lines allowed		
		$a < 0.02\text{mm}$	$0.02\text{mm} \leq a \leq 0.05\text{mm}$ $b \leq 0.5\text{mm}$		

Appendix B

Inspection items and criteria for display defects (continued)

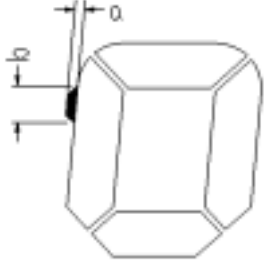
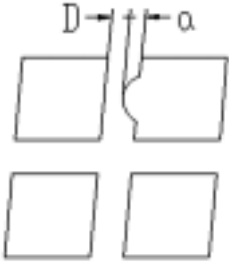
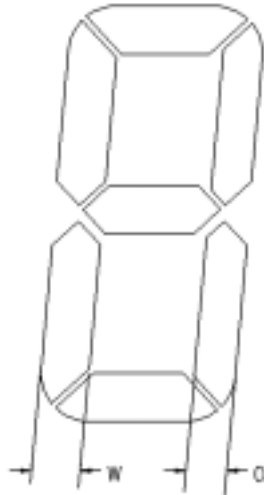
Items	Content	Criteria			
Transformation of segment		Not counted	Max. 2 defects allowed	Max.3 defects allowed	
	$x < 0.1 \text{ mm}$	$0.1 \text{ mm} \leq x \leq 0.2 \text{ mm}$			
	$x = (a+b)/2$				
		Not counted	Max. 1 defects allowed		
	$a < 0.1 \text{ mm}$	$0.1 \text{ mm} \leq a \leq 0.2 \text{ mm}$ $D > 0$			
		Max.2 defects allowed $0.8W \leq a \leq 1.2W$ $a = \text{measured value of width}$ $W = \text{nominal value of width}$			