

Characteristic description

TM1810 is a special circuit for single-channel LED (Light Emitting Diode) constant current driver; LED high-voltage drive circuit is integrated in TM1810; and constant current illumination control is realized by connecting periphery with LED. The product is characterized by excellent performance, simple connection and reliable quality. SOT-23 or TO-92 package type is adopted.

Functions and characteristics

- High-voltage power CMOS technology is adopted;
- Withstand voltage at output port is 24V;
- Any peripheral device is needless;
- Current constant of TM1810-2 is 18mA ($\pm 3\%$) ;
- Current constant of TM1810-3 is 30mA ($\pm 3\%$) ;
- Package type is SOT-23 TO-92.

Internal structure diagram

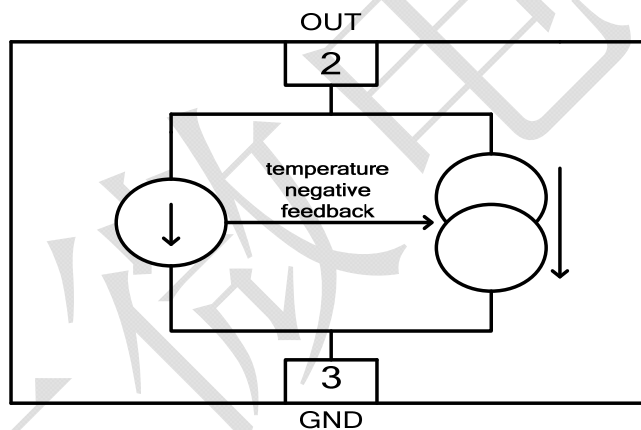

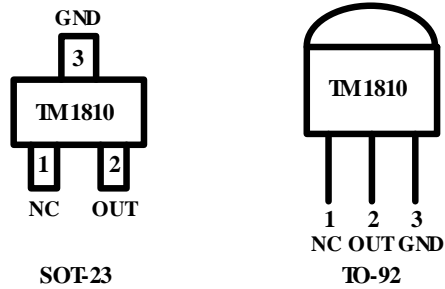
Pin information

Functions of pin

Symbol	SOT-23	TO-92	Name of pin	Introduction
NC	1	1	Empty pin	No internal connection
OUT	2	2	LED drive output	Control output of lighting LED; connecting LED cathode to the pin
GND	3	3	Logic ground	Connecting to system ground



As an electrostatic sensitive device, integrated circuit can generate a lot of static electricity easily in dry season or dry environment; electrostatic discharge is likely to damage integrated circuit, so Titan Micro Electronics suggests adopting all suitable electrostatic preventive measures for integrated circuit. Improper operation and welding may damage ESD or reduce performance of ESD so that chips cannot work normally.

Electric parameters
Limit parameters (Ta = 25°C, Vss = 0 V) ⁽¹⁾ ⁽²⁾

Parameter	Symbol	Scope (typical value)	Unit
Withstand voltage at output port	Vout	24	V
Power loss	PD	400	mW
Operating temperature	Topt	-40 ~ +80	°C
Storage temperature	Tstg	-65 ~ +150	°C

(1) Chips work under the limit parameters for a long time may reduce reliability of device or damage device permanently; and Titan Micro Electronics does not suggest that any parameter achieves or exceeds these limit values when being used.

(2) All voltage values are tested relatively to system.

Normal working scope (Ta = -20 ~ +70°C, Vss = 0 V)

Parameter	Symbol	Minimum	Typical case	Maximum	Unit	Testing condition
Logic power supply voltage	OUT	2.5	3	24	V	TM1810-2: 18mA TM1810-3: 30mA

Note: TM1810 is a temperature negative feedback type device; when temperature rises, current value which is 2mA at the highest is likely to reduce.

Application information

1. Application schematic diagram for typical constant current driver is as follows:

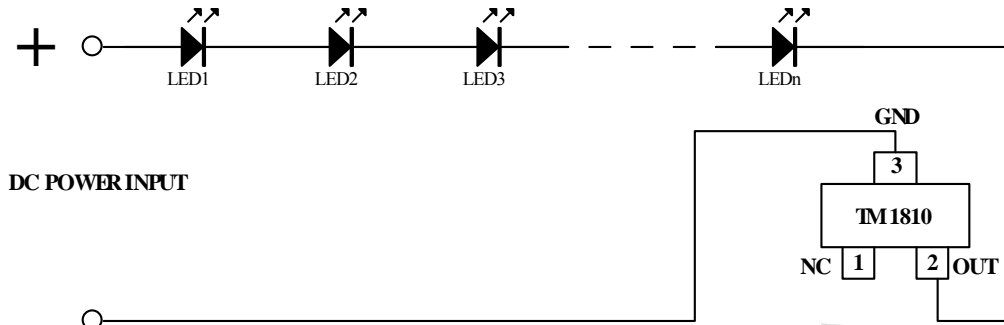

Figure 1

As shown in Figure 1, TM1810 can work under constant current state as long as voltage on OUT pin of chip is greater than 2.5V, that is to say, voltage between the second pin and the third pin of chip should be above 2.5V. In actual application, voltage added on OUT pin after power is serially connected with LED lamp is suggested being set around 3.0V. If chip continuously works under rated constant current state, OUT pin voltage of TM1810-2 and OUT pin voltage of TM1810-3 are respectively within 12.0V and 8.0V properly.

If OUT pin of chip keeps higher voltage for a long time, the power consumption of chip is greater and the chip can heat obviously so that the chip may be damaged; the device parameter should be reasonably configured according to actual use condition. If higher power voltage and little serial LED quantity result in higher working voltage on OUT pin of TM1810, resistance with suitable resistance value and package power is suggested to be serially connected for voltage division; and it is as shown in Figure 2:

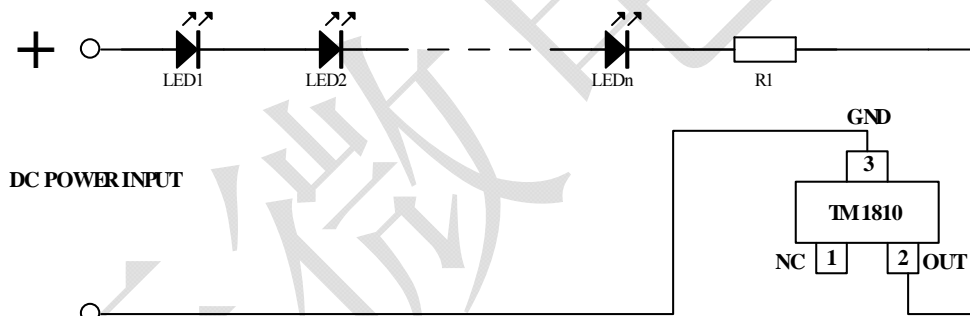

Figure 2

In Figure 2, resistance value of resistance R1 should be calculated according to power voltage, pressure drop of used LED lamp and quantity of serial LED lamp; the specific calculation formula is as follows: (working voltage on OUT pin of TM1810 is set as 3.0V)

When using TM1810-2, $R = (\text{power voltage} - \text{LED lamp voltage drop} \times \text{serial quantity} - 3.0V) / 0.018A$

When using TM1810-3, $R = (\text{power voltage} - \text{LED lamp voltage drop} \times \text{serial quantity} - 3.0V) / 0.03A$

For example: when power voltage is DC24V, TM1810-2 is used as constant current driver; and when five white-light LED lamp beads are serially connected, resistance value of R is calculated as follows:

$$R = (24V - 3.0V \times 5 \text{ beads} - 3.0V) / 0.018A = 330\Omega$$

Note: Pressure drop of red-light LED lamp is generally calculated within 2.0V; voltage drop of green-light and voltage drop of blue-light LED lamp are generally calculated with 3.0V; and specific calculation should be determined according to parameter specification of LED lamp beads actually used.

2. Application based on PWM dimming

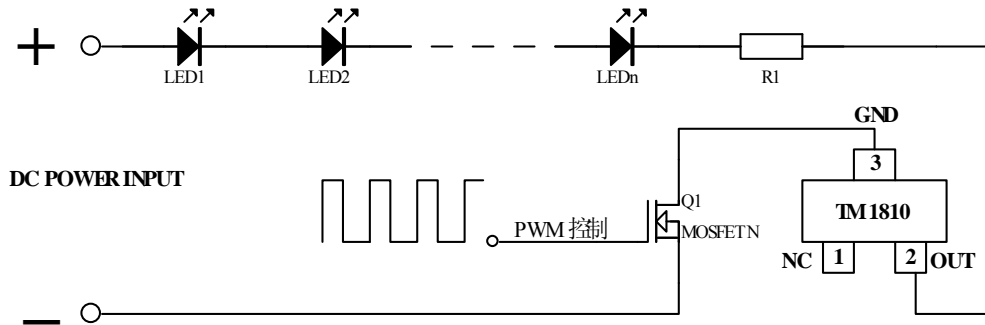

Figure 3

As shown in Figure 3, PWM signal controls the conduction and cutting off of TM1810 via the switch circuit; when chip works in periodic on-off state, withstand voltage at OUT pin of TM1810 can achieve 24V, that is to say, when PWM signal is turned off, voltage at OUT pin of TM1810 can be DC24.0V; while conduction duty cycle shouldn't be too high; and specific application reference is as follows:

TM1810-2: turn-on time duty cycle is less than 50%;

TM1810-3: turn-on time duty cycle is less than 30%.

If the remaining voltage that power voltage deducts overall voltage drop of serial LED lamp is higher, divider resistance R1 should be serially connected to circuit so as to share voltage and power according to Figure 3.

3. Notes of PCB design

In order to reduce working temperature of TM1810, area of PCB copper foil connected with TM1810 pin should be enlarged go the greatest extent so as to achieve better and quick radiating effect. Please refer to the figure below.

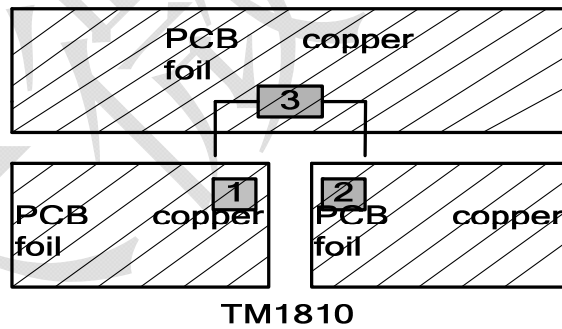

TM1810

Package diagram (SOT-23)

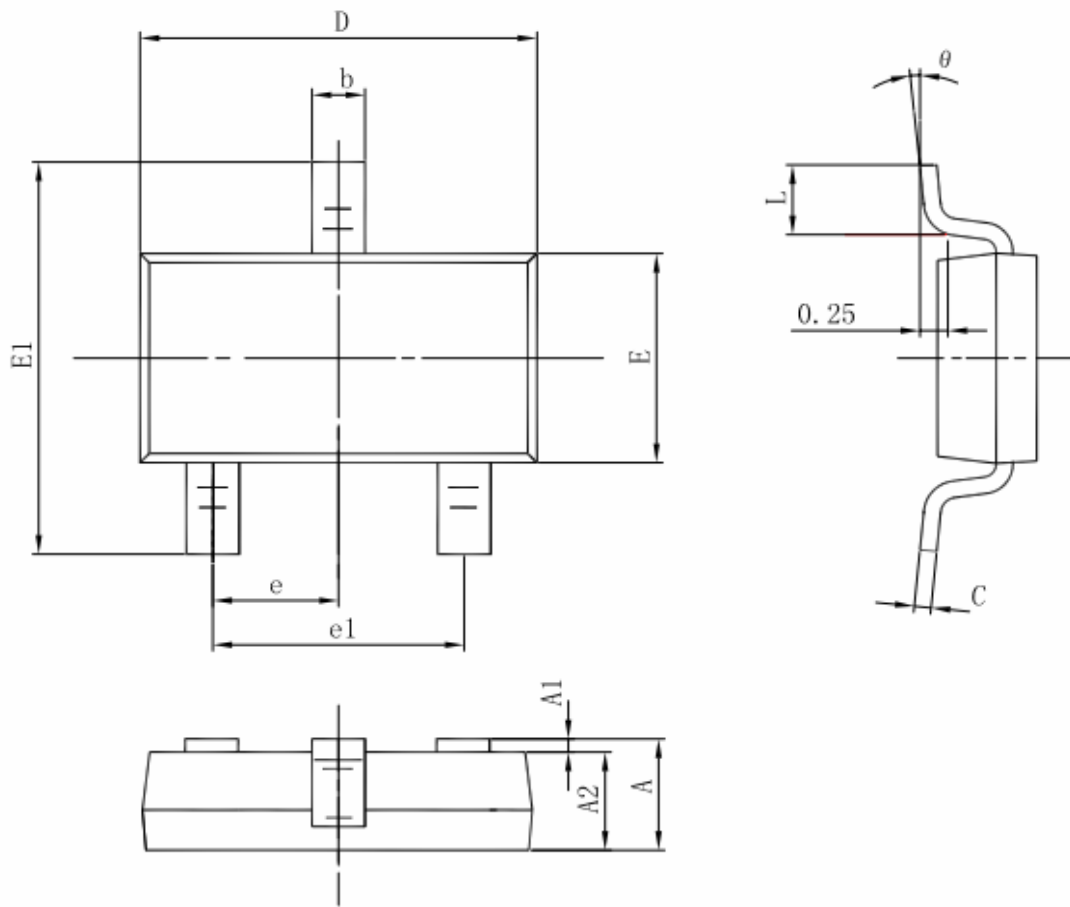

Symbol	Dimensions In Millimeters		Dimensions In Inches	
	Min	Max	Min	Max
A	0.700	0.900	0.028	0.035
A1	0.000	0.100	0.000	0.004
A2	0.700	0.800	0.028	0.031
b	0.350	0.500	0.014	0.020
c	0.080	0.200	0.003	0.008
D	2.820	3.020	0.111	0.119
E	1.600	1.700	0.063	0.067
E1	2.650	2.950	0.104	0.116
e	0.95 (BSC)		0.037(BSC)	
e1	1.90 (BSC)		0.075(BSC)	
L	0.300	0.600	0.012	0.024
θ	0°	8°	0°	8°

Package diagram (TO-92)

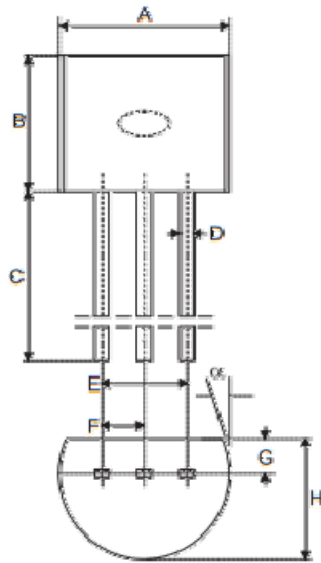

Symbol	Dimensions in inch		
	Min.	Nom.	Max.
A	0.170	—	0.200
B	0.170	—	0.200
C	0.500	—	—
D	0.011	—	0.020
E	0.090	—	0.110
F	0.045	—	0.055
G	0.045	—	0.065
H	0.130	—	0.160
α	0°	—	10°

Symbol	Dimensions in mm		
	Min.	Nom.	Max.
A	4.32	—	5.08
B	4.32	—	5.08
C	12.70	—	—
D	0.28	—	0.51
E	2.29	—	2.79
F	1.14	—	1.40
G	1.14	—	1.65
H	3.30	—	4.06
α	0°	—	10°

- All specs and applications shown above are subject to change without prior notice.