



十速

# TM52F1364

## *DATA SHEET Rev 0.91*

*(Please read the precautions on the second page before use)*

**tenx** reserves the right to change or discontinue the manual and online documentation to this product herein to improve reliability, function or design without further notice. **tenx** does not assume any liability arising out of the application or use of any product or circuit described herein; neither does it convey any license under its patent rights nor the rights of others. **tenx** products are not designed, intended, or authorized for use in life support appliances, devices, or systems. If Buyer purchases or uses **tenx** products for any such unintended or unauthorized application, Buyer shall indemnify and hold **tenx** and its officers, employees, subsidiaries, affiliates and distributors harmless against all claims, cost, damages, and expenses, and reasonable attorney fees arising out of, directly or indirectly, any claim of personal injury or death associated with such unintended or unauthorized use even if such claim alleges that **tenx** was negligent regarding the design or manufacture of the part.

---

## PRECAUTIONS

1. The chip cannot enter Halt/Stop mode if the INTn pin is low and the INTn wake-up function is enabled. (INTn=0 and EXn=1, n=0~2)
2. If you need to use LVR, it is recommended to set the LVR (SFR LVRSEL) first after the program is powered on, and then change the default value related to the pin.

## AMENDMENT HISTORY

Version	Date	Description
V0.90	Apr, 2023	
V0.91	Dec, 2023	Flash IAP needs to be written twice @ VCC = 5.0V~5.5V Added EEPROM writing condition: SFR.IVCPD=1

# CONTENTS

<b>PRECAUTIONS</b> .....	<b>2</b>
<b>AMENDMENT HISTORY</b> .....	<b>3</b>
<b>GENERAL DESCRIPTION</b> .....	<b>6</b>
<b>SYSTEM BLOCK DIAGRAM</b> .....	<b>6</b>
<b>FEATURES</b> .....	<b>7</b>
<b>PIN ASSIGNMENT</b> .....	<b>11</b>
<b>PIN DESCRIPTION</b> .....	<b>13</b>
<b>PIN SUMMERY</b> .....	<b>14</b>
<b>FUNCTIONAL DESCRIPTION</b> .....	<b>15</b>
1. CPU Core.....	15
1.1 Accumulator (ACC).....	15
1.2 B Register (B) .....	15
1.3 Stack Pointer (SP) .....	16
1.4 Dual Data Pointer (DPTRs).....	16
1.5 Program Status Word (PSW) .....	17
2. Memory.....	18
2.1 Program Memory (Support IAP).....	19
2.2 Information Memory (Support IAP) .....	24
2.3 EEPROM Memory .....	27
2.4 IRAM .....	29
2.5 XRAM.....	29
2.6 Special Function Register (SFR).....	29
3. Reset.....	31
3.1 Power on Reset (POR) .....	31
3.2 External Pin Reset (XRST) .....	31
3.3 Software Command Reset (SWRST).....	31
3.4 Watchdog Timer Reset (WDTR) .....	31
3.5 Low Voltage Reset (LVR) .....	31
4. Clock Circuitry & Operation Mode .....	35
4.1 System Clock .....	35
4.2 Operation Modes .....	37
4.3 IVC (Build-in VDD regulator).....	39
5. Interrupt & Wake-up.....	40
5.1 Interrupt Enable and Priority Control.....	41
5.2 Pin Interrupt .....	43
5.3 Idle mode Wake up and Interrupt.....	44
5.4 Halt/Stop mode Wake up and Interrupt.....	44
6. I/O Ports .....	49
7. Timers .....	59
7.1 Timer0 / Timer1 .....	59

7.2	Timer2	62
7.3	Timer3	64
8.	UART	65
9.	PWMs	68
9.1	PWM0	68
9.2	PWM1~PWM6	72
10.	Touch Key	79
11.	Low Voltage Detection (LVD)	84
12.	ADC	86
13.	S/W Controller LCD Driver	90
14.	Full Color LED Communication Format Waveform Generator	93
15.	Operational Amplifier and Comparator	96
16.	Serial Peripheral Interface (SPI)	101
17.	Cyclic Redundancy Check (CRC)	106
18.	Multiplier and Divider	107
19.	Master I <sup>2</sup> C Interface	109
20.	In Circuit Emulation (ICE) Mode	114
<b>SFR &amp; CFGW MAP</b>		<b>116</b>
<b>SFR &amp; CFGW DESCRIPTION</b>		<b>119</b>
<b>INSTRUCTION SET</b>		<b>135</b>
<b>ELECTRICAL CHARACTERISTICS</b>		<b>138</b>
1.	Absolute Maximum Ratings	138
2.	DC Characteristics	139
3.	Clock Timing	140
4.	Reset Timing Characteristics	140
5.	LVR Circuit Characteristics	140
6.	LVD Circuit Characteristics	141
7.	ADC Electrical Characteristics	141
8.	OPA Electrical Characteristics	142
9.	Comparator Characteristics	142
10.	EEPROM Characteristics	142
11.	Characteristic Graphs	143
<b>Package and Dice Information</b>		<b>146</b>

## GENERAL DESCRIPTION

TM52<sub>series</sub> F1364 are versions of a new, fast 8051 architecture for an 8-bit microcontroller single chip with an instruction set fully compatible with industry standard 8051, and retains most 8051 peripheral's functional block. Typically, the TM52 executes instructions six times faster than the standard 8051 architecture.

The TM52-F1364 provides improved performance, lower cost and fast time-to-market by integrating features on the chip, including 16K Bytes Flash program memory, 128 Bytes EEPROM, 1024 Bytes SRAM, Low Voltage Reset (LVR), Low Voltage Detector (LVD), dual clock power saving operation mode, 8051 standard UART and Timer0/1/2, real time clock Timer3, 7 sets 16-bit PWMs, 19 channels 12-bit A/D Converter, 8-channel Touch Key, master I<sup>2</sup>C interface, SPI interface, Full color LED communication format waveform generator, S/W control 1/2 bias LCD COM, OPA, CMP with DAC and Watch Dog Timer. It's a high reliability and low power consumption feature can be widely applied in consumer and home appliance products.

## SYSTEM BLOCK DIAGRAM

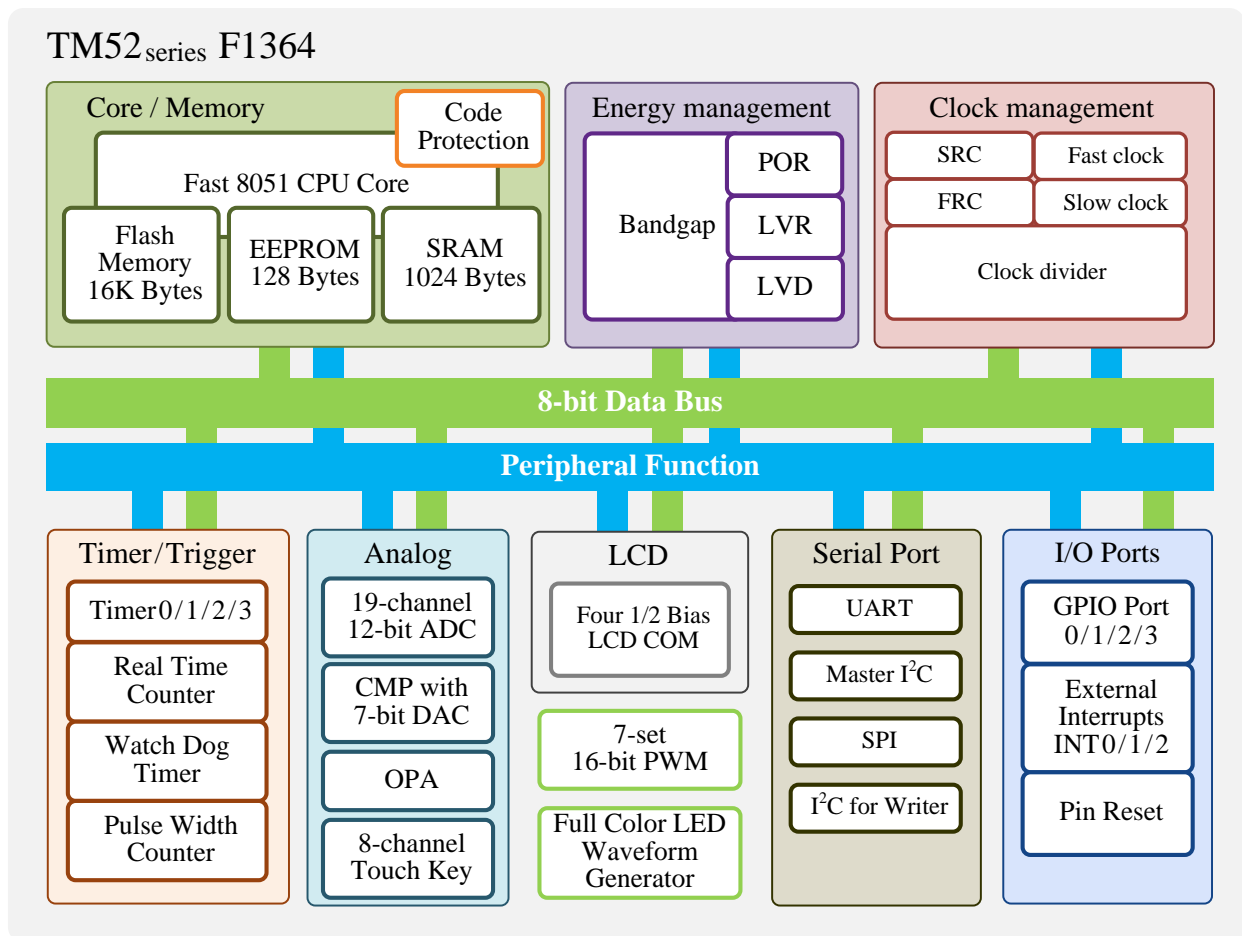

## FEATURES

- 1. Standard 8051 Instruction set, fast machine cycle**
  - Executes instructions six times faster than the standard 8051.
- 2. Flash Program Memory**
  - 16K Bytes Flash program memory
  - Support “In Circuit Programming” (ICP) or “In System Programming” (ISP) for the Flash code
  - Code Protection Capability
  - BOOT vector option
  - 10K erase times at least
  - 10 years data retention at least
- 3. 128 Bytes EEPROM Memory**
  - 50K erase times at least
  - 10 years data retention at least
- 4. Total 1024 Bytes SRAM (IRAM + XRAM)**
  - 256 Bytes IRAM in the 8051 internal data memory area
  - 768 Bytes XRAM in the 8051 external data memory area (accessed by MOVX Instruction)
- 5. Two System Clock type selections**
  - Fast clock from Internal RC (FRC, 16.588 MHz)
  - Slow clock from Internal RC (SRC, 41 KHz)
  - System Clock can be divided by 1/2/4/16 option
- 6. 8051 Standard Timer – Timer0/1/2**
  - 16-bit Timer0, also supports T0O clock output for Buzzer application
  - 16-bit Timer1, also supports T1O clock output for Buzzer application
  - 16-bit Timer2, also supports T2O clock output for Buzzer application
- 7. 15-bit Timer3**
  - Clock source is Slow clock
  - Interrupt period can be clock divided by 32768/4096/2048/512/25600/3200/1600/400 option
- 8. One UART**
  - 8051 standard UART, One Wire UART option can be used for ISP or other application
  - Additional baud rate generator option

\*Support one UART, pin select to P30/P31 or P02/P16 by TXRXSEL (SFR 93h.7)

**9. Seven 16-bit PWMs with prescaler/ period-adjustment****10. One Master I<sup>2</sup>C interface (MIIC)**

\*Support one MIIC, pin select to P35/P16 by MSDASEL (SFR B7h.7) , pin select to P13/P02 by MSCLSEL (SFR B7h.6)

**11. One SPI interface****12. Full Color LED Communication Format Waveform Generator****13. 12-bit ADC with 19 channels External Pin Input and 3 channels Internal Reference Voltage**

- Internal Reference Voltage VBG, OPO,  $1/4V_{CC}$

**14. 8-channel Touch Key****15. Operational Amplifier**

- Build-in 4-level OPA gain 1/20/50/100

**16. Comparator**

- With 7-bit DAC output for comparator negative input
- DAC reference voltage can select VCC or VBG (1.20V/2.49V)
- DAC can output to PAD

**17. LDO 1.2V High Driver Current Output (60mA)****18. 4-level LDO Regulator for Internal Digital Circuit**

- 1.70V/1.95V/2.20V/2.45V

**19. LCD Driver**

- Software controlled COM0~3
- 1/2 LCD Bias

**20. 14 Sources, 4-level priority Interrupt**

- Timer0/Timer1/Timer2/Timer3 Interrupt
- INT0/INT1 pin Falling-Edge/Low-Level Interrupt
- INT2 pin Falling-Edge Interrupt
- Port0/1/2/3 Pin Change Interrupt
- UART TX/RX Interrupt
- ADC/TK Interrupt
- MIIC/SPI Interrupt
- LVD Interrupt
- CMP Interrupt
- PWM0/PWM1 Interrupt

**21. Pin Interrupt can Wake up CPU from Power-Down (Halt/Stop) mode**

- INT0~INT2 Interrupt & Wake-up
- Each Port0/1/2/3 pin can be defined as Interrupt & Wake-up pin (by pin change)

**22. Max. 26 Programmable I/O pins**



- CMOS Output
- Pseudo-Open-Drain, or Open-Drain Output
- Schmitt Trigger Input
- Pin Pull-up can be Enabled or Disabled

### 23. Independent RC Oscillating Watch Dog Timer

- 400ms/200ms/100ms/50ms selectable WDT timeout options

### 24. Five types Reset

- Power on Reset
- Selectable External Pin Reset
- Selectable Watch Dog Reset
- Software Command Reset
- Selectable Low Voltage Reset

### 25. 16-level Low Voltage Reset

- 2.05V / 2.19V / 2.33V / 2.47V / 2.61V / 2.75V / 2.89V / 3.03V / 3.17V / 3.31V / 3.45V / 3.59V / 3.73V / 3.87V / 4.01V / 4.15V

### 26. 15-level Low Voltage Detect

- 2.19V / 2.33V / 2.47V / 2.61V / 2.75V / 2.89V / 3.03V / 3.17V / 3.31V / 3.45V / 3.59V / 3.73V / 3.87V / 4.01V / 4.15V
- LVD detect polarity option
- LVD Hysteresis 30mV~80mV

### 27. Five Power Operation Modes

- Fast/Slow/Idle/Halt/Stop mode

### 28. Integrated 16-bit Cyclic Redundancy Check function

### 29. Multiplication and division

- 8 bits Multiplier & Divider (standard 8051)
- 16 bits Multiplier & Divider
- 32 bits ÷ 16 bits Divider

### 30. On-chip Debug/ICE interface

- Use P3.0/P3.1 pin or P2.0/P2.1 pin
- Share with ICP programming pin
- Mass production writer only supports P3.0/P3.1

### 31. Operating Voltage and Current

- $V_{CC} = 2.2V \sim 5.5V$  @ $F_{SYS} = 16.588$  MHz
- $I_{CC} = 0.2\mu A$  @Stop mode, PWRSAV=1,  $V_{CC} = 3V$
- $I_{CC} = 2.4\mu A$  @Halt mode, PWRSAV=1,  $V_{CC} = 3V$
- $I_{CC} = 4.1\mu A$  @Idle mode, PWRSAV=1, PORPD=1,  $V_{CC} = 3V$

**32. Operating Temperature Range**

- $-40^{\circ}\text{C} \sim +105^{\circ}\text{C}$

**33. Package Types**

- 28-pin SOP (300 mil)
- 28-pin SSOP (150 mil)
- 28-pin QFN (4x4x0.75-0.4mm)

## PIN ASSIGNMENT

\*UART default pin is P30, P31; user can set P02, P16 instead by TXRXSEL (SFR 93h.7)

\*Master I<sup>2</sup>C SDA default pin is P35; user can set P16 instead by MSDASEL (SFR B7h.7)

\*Master I<sup>2</sup>C SCL default pin is P13; user can set P02 instead by MSCLSEL (SFR B7h.6)

For low power applications, all digital I/Os (including unbonding or unused) should avoid high-impedance settings.

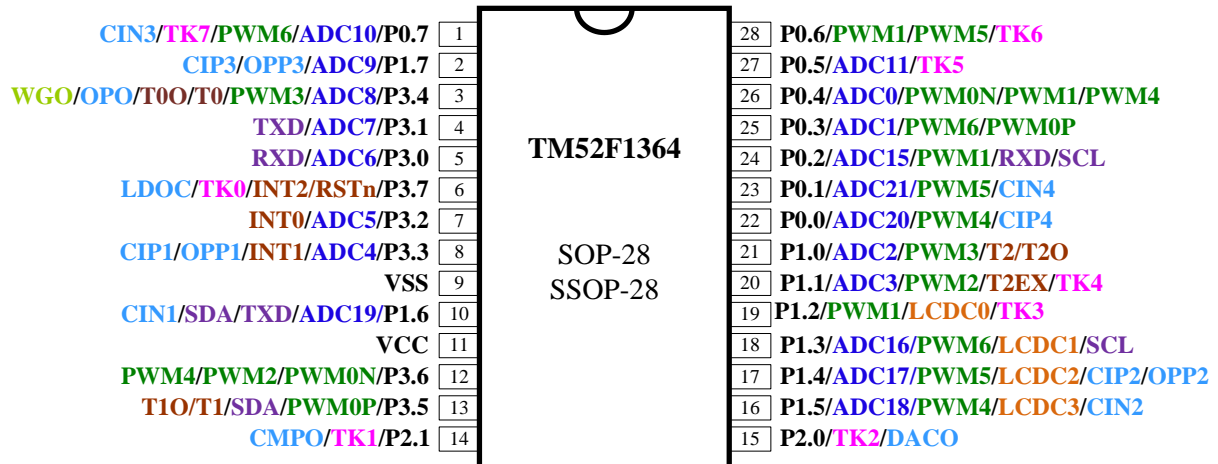

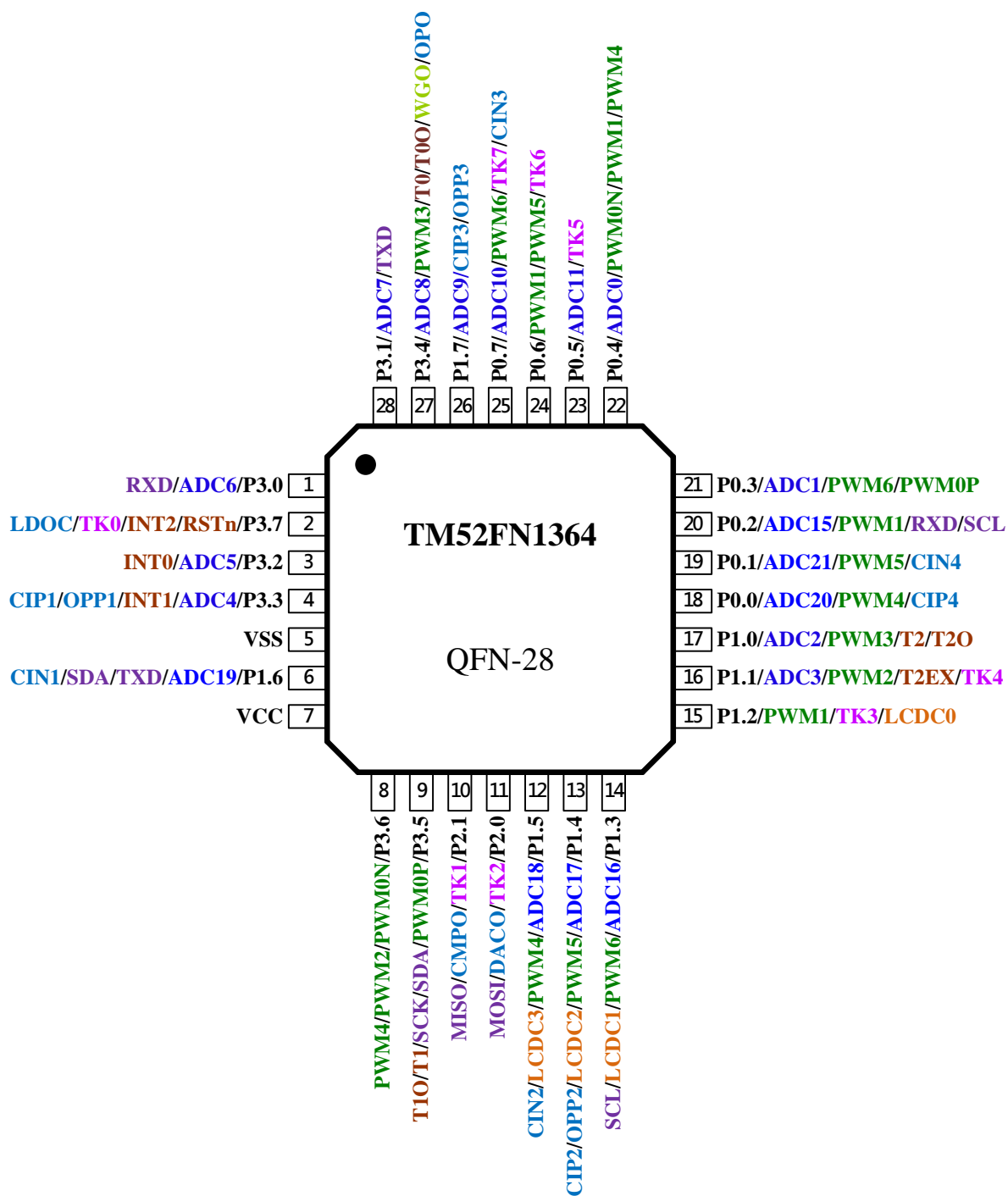

**PIN DESCRIPTION**

Name	In/Out	Pin Description
P0.0~P0.7 P1.0~P1.7 P2.0~P2.1 P3.3~P3.7	I/O	Bit-programmable I/O port for Schmitt-trigger input or CMOS push-pull output. Pull-up resistors are assignable by software. These pin's level change can interrupt/wake up CPU from Idle/Stop mode.
P3.0~P3.2	I/O	Bit-programmable I/O port for Schmitt-trigger input, CMOS push-pull output or " <b>pseudo open drain</b> " output. Pull-up resistors are assignable by software. These pin's level change can interrupt/wake up CPU from Idle/Stop mode.
INT0, INT1	I	External low level or falling edge Interrupt input, Idle/Stop mode wake up input.
INT2	I	External falling edge Interrupt input, Idle/Stop mode wake up input.
RXD	I/O	UART Mode0 transmit & receive data, Mode1/2/3 receive data
TXD	I/O	UART Mode0 transmit clock, Mode1/2/3 transmit data. In One Wire UART mode, this pin transmits and receives serial data.
T0, T1, T2	I	Timer0, Timer1, Timer2 event count pin input.
T2EX	I	Timer2 external trigger input.
T0O	O	Timer0 overflow divided by 64 output
T1O	O	Timer1 overflow divided by 2 output
T2O	O	Timer2 overflow divided by 2 output
PWM1~PWM6 PWM0P/PWM0N	O	16 bit PWM output
ADC0~ADC11, ADC15~ADC21	I	ADC input
LCDC0~LCDC3	O	LCD 1/2 bias output
SCL	I/O	Master I <sup>2</sup> C (MIIC) SCL
SDA	I/O	Master I <sup>2</sup> C (MIIC) SDA
SCK	I/O	SPI clock
MISO, MOSI	I/O	SPI data input and output
TK0~TK7	I	Touch Key input
CIN1~CIN4	I	Comparator negative port input
CIP1~CIP4	I	Comparator positive port input
CMPO	O	Comparator status output
DACO	O	DAC output
OPP1~OPP4	I	OPA positive port input
OPO	O	OPA output
LDOC	O	LDO 1.2V high driver current output
WGO	O	Full color LED waveform generator output
RSTn	I	External active low reset input, Pull-up resistor is fixed enable.
VCC, VSS	P	Power input pin and ground

**PIN SUMMERY**

Pin Number	Pin Name	Type	Input			Output			Alternative Function					MISC		
			Pull-up Control	Wake up	Ext. Interrupt	CMOS Push-Pull	Pseudo Open Drain	Open Drain	LCD	ADC	Touch Key	PWM	OPA / CMP / DAC		MHC / SPI	
1	RXD/ADC6/P3.0	I/O	•	•		•	•	•		•						
2	INT2/RSTn/LDOC/TK0/P3.7	I/O	•	•	•	•		•			•					Reset
3	INT0/VBGO/ADC5/P3.2	I/O	•	•	•	•	•	•		•						VBGO
4	INT1/CIP1/OPP1/ADC4/P3.3	I/O	•	•	•	•		•		•			•			
5	VSS	P														
6	CIN1/SDA/TXD/ADC19/P1.6	I/O	•	•		•		•		•			•	•		
7	VCC	P														
8	PWM4/PWM2/PWM0N/P3.6	I/O	•	•		•		•				•				
9	T1O/T1/SCK/SDA/PWM0P/P3.5	I/O	•	•		•		•				•		•		T1O
10	CMPO/MISO/TK1/P2.1	I/O	•	•		•		•			•		•	•		
11	DACO/MOSI/TK2/P2.0	I/O	•	•		•		•			•		•	•		
12	CIN2/LCDC3/PWM4/ADC18/P1.5	I/O	•	•		•		•	•	•			•	•		
13	CIP2/OPP2/LCDC2/PWM5/ADC17/P1.4	I/O	•	•		•		•	•	•			•	•		
14	SCL/LCDC1/PWM6/ADC16/P1.3	I/O	•	•		•		•	•	•			•		•	
15	LCDC0/PWM1/TK3/P1.2	I/O	•	•		•		•	•		•	•				
16	T2EX/PWM2/TK4/ADC3/P1.1	I/O	•	•		•		•		•	•	•				
17	T2O/T2/PWM3/ADC2/P1.0	I/O	•	•		•		•		•		•				T2O
18	CIP4/PWM4/ADC20/P0.0	I/O	•	•		•				•		•	•			
19	CIN4/PWM5/ADC21/P0.1	I/O	•	•		•				•		•	•			
20	SCL/RXD/PWM1/ADC15/P0.2	I/O	•	•		•				•		•		•		
21	PWM0P/PWM6/ADC1/P0.3	I/O	•	•		•				•		•				
22	PWM4/PWM1/PWM0N/ADC0/P0.4	I/O	•	•		•				•		•				
23	TK5/ADC11/P0.5	I/O	•	•		•				•	•					
24	PWM5/PWM1/TK6/P0.6	I/O	•	•		•					•	•				
25	CIN3/PWM6/TK7/ADC10/P0.7	I/O	•	•		•				•	•	•	•			
26	CIP3/OPP3/ADC9/P1.7	I/O	•	•		•		•		•			•			
27	T0O/T0/OPO/WGO/PWM3/ADC8/P3.4	I/O	•	•		•		•		•		•	•			T0O/WGO
28	TXD /ADC7/P3.1	I/O	•	•		•	•	•		•						

## FUNCTIONAL DESCRIPTION

### 1. CPU Core

In the 8051 architecture, the C programming language is used as a development platform. The TM52 device features a fast 8051 core in a highly integrated microcontroller, allowing designers to be able to achieve improved performance compared to a classic 8051 device. TM52 series microcontrollers provide a complete binary code with standard 8051 instruction set compatibility, ensuring an easy migration path to accelerate the development speed of system products. The CPU core includes an ALU, a program status word (PSW), an accumulator (ACC), a B register, a stack point (SP), DPTRs, a program counter, an instruction decoder, and core special function registers (SFRs).

#### 1.1 Accumulator (ACC)

This register provides one of the operands for most ALU operations. Accumulators are generally referred to as A or Acc and sometimes referred to as Register A. In this document, the accumulator is represented as “A” or “ACC” including the instruction table. The accumulator, as its name suggests, is used as a general register to accumulate the intermediate results of a large number of instructions. The accumulator is the most important and frequently used register to complete arithmetic and logical operations. It holds the intermediate results of most arithmetic and logic operations and assists in data transportation.

SFR E0h	Bit 7	Bit 6	Bit 5	Bit 4	Bit 3	Bit 2	Bit 1	Bit 0
<b>ACC</b>	ACC.7	ACC.6	ACC.5	ACC.4	ACC.3	ACC.2	ACC.1	ACC.0
R/W	R/W	R/W	R/W	R/W	R/W	R/W	R/W	R/W
Reset	0	0	0	0	0	0	0	0

E0h.7~0 **ACC**: Accumulator

#### 1.2 B Register (B)

The “B” register is very similar to the ACC and may hold a 1 Byte value. This register provides the second operand for multiply or divide instructions. Otherwise, it may be used as a scratch pad register. The B register is only used by two 8051 instructions, MUL and DIV. When A is to be multiplied or divided by another number, the other number is stored in B. For MUL and DIV instructions, it is necessary that the two operands are in A and B.

ex: DIV AB

When this instruction is executed, data inside A and B are divided, and the answer is stored in A.

SFR F0h	Bit 7	Bit 6	Bit 5	Bit 4	Bit 3	Bit 2	Bit 1	Bit 0
<b>B</b>	B.7	B.6	B.5	B.4	B.3	B.2	B.1	B.0
R/W	R/W	R/W	R/W	R/W	R/W	R/W	R/W	R/W
Reset	0	0	0	0	0	0	0	0

F0h.7~0 **B**: B register

### 1.3 Stack Pointer (SP)

The SP register contains the Stack Pointer. The Stack Pointer is used to load the program counter into memory during LCALL and ACALL instructions and is used to retrieve the program counter from memory in RET and RETI instructions. The stack may also be saved or loaded using PUSH and POP instructions, which also increment and decrement the Stack Pointer.

SFR 81h	Bit 7	Bit 6	Bit 5	Bit 4	Bit 3	Bit 2	Bit 1	Bit 0
<b>SP</b>	SP							
R/W	R/W							
Reset	0	0	0	0	0	1	1	1

81h.7~0 **SP:** Stack Point

### 1.4 Dual Data Pointer (DPTRs)

TM52 device has two DPTRs, which share the same SFR address. Each DPTR is 16 bits in size and consists of two registers: the DPTR high byte (DPH) and the DPTR low byte (DPL). The DPTR is used for 16-bit-address external memory accesses, for offset code byte fetches, and for offset program jumps. Setting the DPSEL control bit allows the program code to switch between the two physical DPTRs.

SFR 82h	Bit 7	Bit 6	Bit 5	Bit 4	Bit 3	Bit 2	Bit 1	Bit 0
<b>DPL</b>	DPL							
R/W	R/W							
Reset	0	0	0	0	0	0	0	0

82h.7~0 **DPL:** Data Point low byte

SFR 83h	Bit 7	Bit 6	Bit 5	Bit 4	Bit 3	Bit 2	Bit 1	Bit 0
<b>DPH</b>	DPH							
R/W	R/W							
Reset	0	0	0	0	0	0	0	0

83h.7~0 **DPH:** Data Point high byte

SFR F8h	Bit 7	Bit 6	Bit 5	Bit 4	Bit 3	Bit 2	Bit 1	Bit 0
<b>AUX1</b>	CLRWDT	CLRTM3	–	ADSOC	CLRPWM0	CLRPWM1	LDOCOUT	DPSEL
R/W	R/W	R/W	–	R/W	R/W	R/W	R/W	R/W
Reset	0	0	–	0	1	1	0	0

F8h.0 **DPSEL:** Active DPTR Select



### 1.5 Program Status Word (PSW)

This register contains status information resulting from CPU and ALU operations. The instructions that affect the PSW are listed below.

Instruction	Flag			Instruction	Flag		
	C	OV	AC		C	OV	AC
ADD	X	X	X	CLR C	0		
ADDC	X	X	X	CPL C	X		
SUBB	X	X	X	ANL C, bit	X		
MUL	0	X		ANL C, /bit	X		
DIV	0	X		ORL C, bit	X		
DA	X			ORL C, /bit	X		
RRC	X			MOV C, bit	X		
RLC	X			CJNE	X		
SETB C	1						

A “0” means the flag is always cleared, a “1” means the flag is always set and an “X” means that the state of the flag depends on the result of the operation.

SFR D0h	Bit 7	Bit 6	Bit 5	Bit 4	Bit 3	Bit 2	Bit 1	Bit 0
<b>PSW</b>	CY	AC	F0	RS1	RS0	OV	F1	P
R/W	R/W	R/W	R/W	R/W	R/W	R/W	R/W	R/W
Reset	0	0	0	0	0	0	0	0

- D0h.7 **CY**: ALU carry flag
- D0h.6 **AC**: ALU auxiliary carry flag
- D0h.5 **F0**: General purpose user-definable flag
- D0h.4~3 **RS1, RS0**: The contents of (RS1, RS0) enable the working register banks as:
  - 00: Bank 0 (00h~07h)
  - 01: Bank 1 (08h~0Fh)
  - 10: Bank 2 (10h~17h)
  - 11: Bank 3 (18h~1Fh)
- D0h.2 **OV**: ALU overflow flag
- D0h.1 **F1**: General purpose user-definable flag
- D0h.0 **P**: Parity flag. Set/cleared by hardware each instruction cycle to indicate odd/even number of “one” bits in the accumulator.

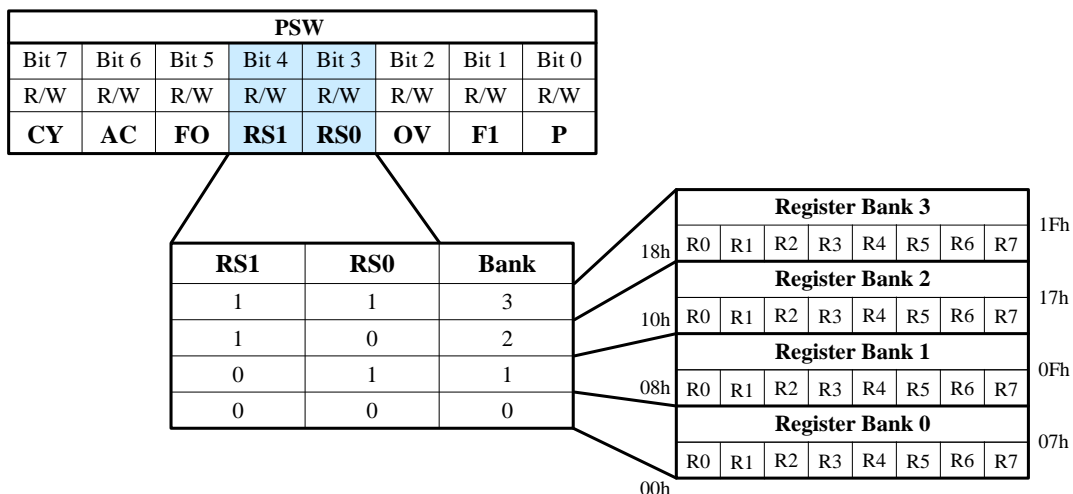

## 2. Memory

As the standard 8051, the Chip has both Internal and External Data Memory space. The Internal Data Memory space consists of 256 bytes IRAM and SFRs, which are accessible through a rich instruction set. The External Data Memory space consists of 768 bytes XRAM, 128 bytes EEPROM, 24 bytes WG RAM, 64 bytes INFO memory and 16K bytes Program memory, which can be only accessed by MOVX instruction, Program memory also can be accessed by MOVC instruction.

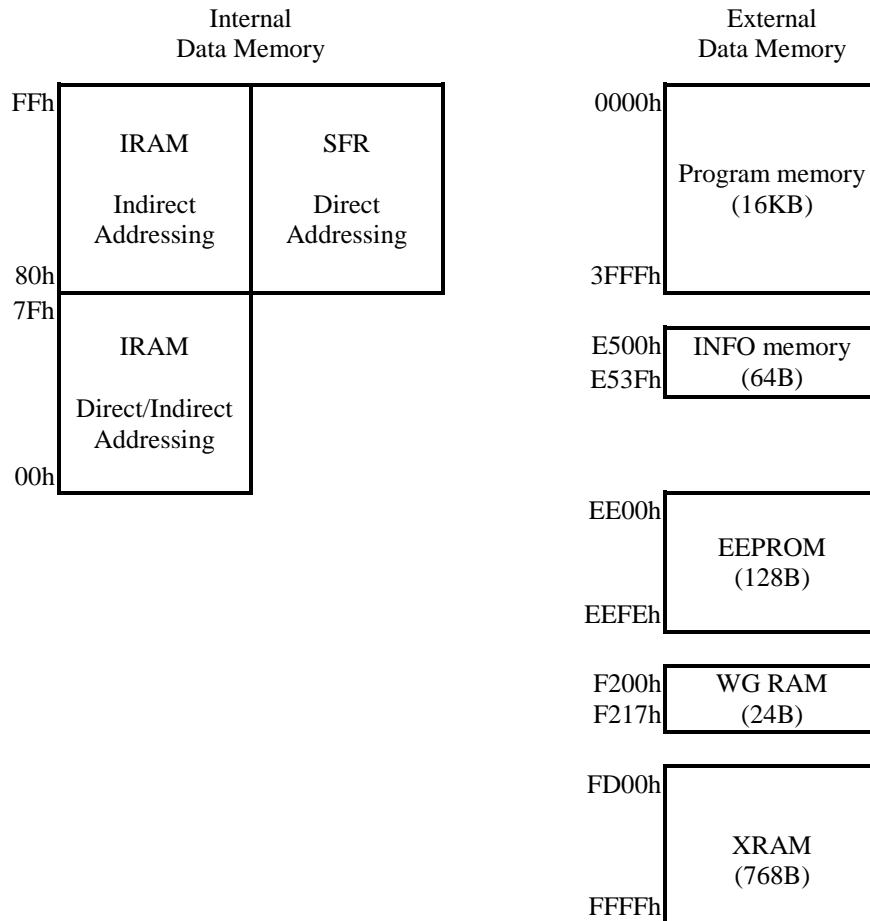

## 2.1 Program Memory (Support IAP)

The Chip has a 16K bytes Flash program memory which can support In Circuit Programming (ICP), In Application Programming (IAP) and In System Programming (ISP) function modes. The program memory address continuous space (0000h~3FFFh) is partitioned to several sectors for device operation.

### 2.1.1 Functional Partition

The last 16 bytes (3FF0h~3FFFh) of program memory is defined as chip Configuration Word (CFGW), which is loaded into the device control registers upon power on reset (POR). The 0000h~007Fh is occupied by Reset/Interrupt vectors as standard 8051 definition. In the in-circuit emulation (ICE) mode, user also needs to reserve the address space 2D00h~2FFFh for ICE System communication. CRC16H/L is the reserved area of the checksum. Tenx can provide a CRC verification subroutine. The user can calculate the checksum by the CRC verification subroutine to compare with CRC16H/L and check the validity of the ROM code.

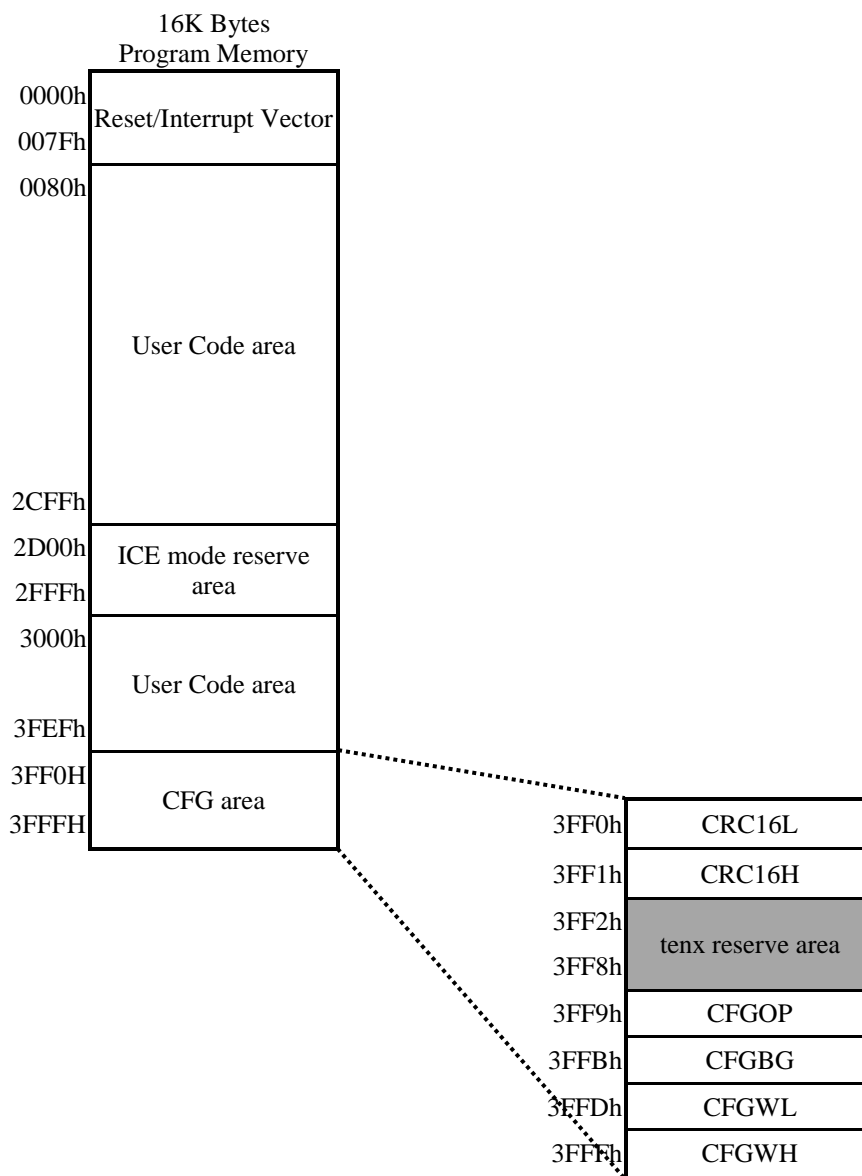

Program Memory Partition

User can select different BOOT mode by CFGH.3~2. If CFGH.3~2=0, reset vector=0x3800 and BOOT area is 2KB, if CFGH.3~2=1, reset vector=0x3000 and BOOT area is 4KB, if CFGH.3~2=2 or 3, Boot mode is disable. User also can keep reset vector to 0x0000 in BOOT mode by set RSTV=0 (BFh.2).

Only App area can IAP write. In different BOOT modes, the writable area is also different; see the figure below for details.

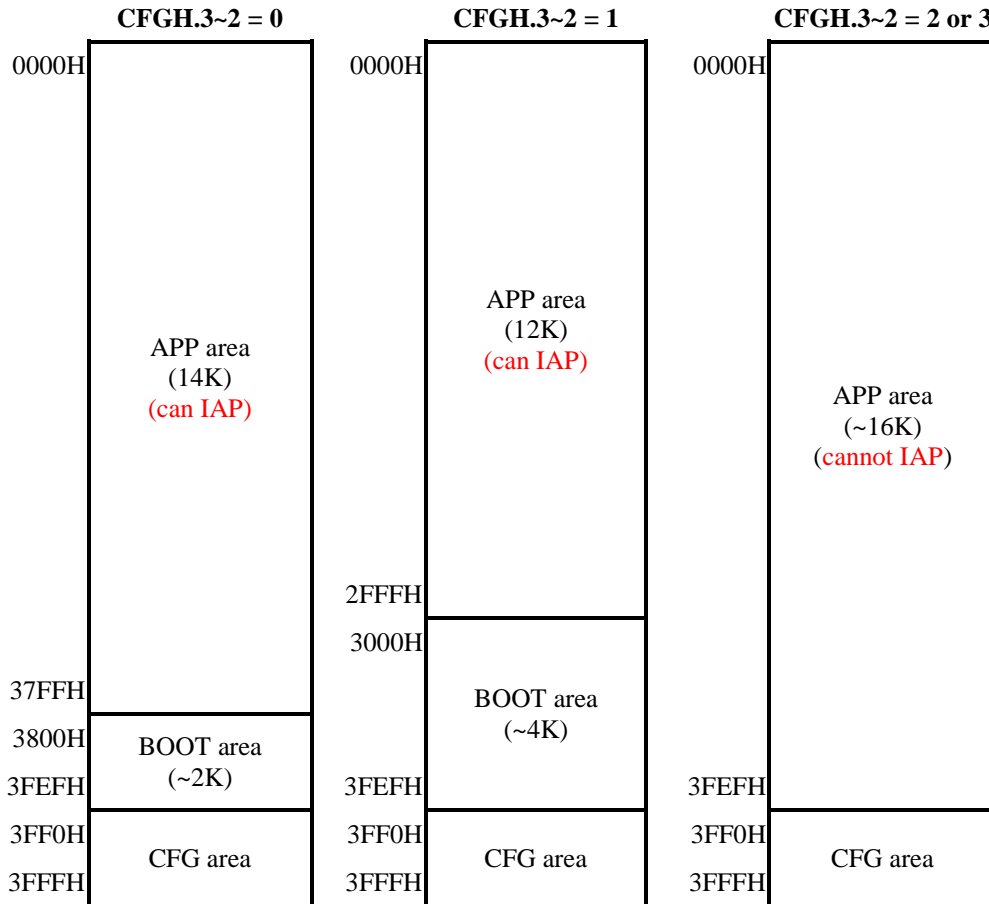

**Flash partition determined by different BOOT modes**

### 2.1.2 Flash IAP Mode

The chip has “In Application Program” (IAP) capability, which allows software to read/write data from/to the Flash memory during CPU run time as conveniently as data EEPROM access. The IAP function is byte writable, meaning that the chip does not need to erase one Flash page before write.

Both write 47h and 74h to IAPCON (C9h.7~0) can let IAPWE=1, the difference is when user write 47h to IAPCON, user can write one byte at once, when user write 74h to IAPCON, user can write two byte at once to save write time.

When IAPALL=1 and IAPWE=1, the user is allowed to use the IAP function to write to the APP area in BOOT mode.

To use IAP function, user need to meet the following conditions:

1. In BOOT mode.
2. Only APP area can be written by IAP.
3. Set IAPALL=1 and IAPWE=1.

**Flash IAP Write** is simply achieved by a “MOVX @DPTR, A” instruction while the DPTR contains the target Flash address, and the ACC contains the data being written. The Flash IAP need to be written twice. Flash writing requires approximately 0.6 ms @ $V_{CC}=5.0V\sim 5.5V$ , VCC capacitance greater than 220uF. During the period of IAP, the CPU stays in a waiting state, but all peripheral modules continue running during the writing time. The software must handle the pending interrupts after an IAP write. The chip has a build-in write Time-out function selected by IAPTE (F7h.2~1) to escape write fail state. Besides, S/W must disable WDT before IAP write. The IVC function must be turned off when writing to the Flash.

**Flash IAP Read** can be performed by the “MOVC” or “MOVX” instruction as long as the target address points to the 0000h~3FFFh area. A Flash IAP read does not require extra CPU wait time.

One-byte IAP Example: (In BOOT mode)

```

; need 5.0V < VCC < 5.5V & WDT disable
ANL    AUX2, #3Fh        ; Disable WDT
ORL    PWRCON, #80h      ; IVCPD=1
MOV    DPTR, #1F00h      ; DPTR=1F00h=target IAP address
MOV    A, #5Ah           ; A=5Ah=target IAP write data
ORL    AUX2, #04h        ; IAP Time-Out function select
MOV    SWCMD, #65h       ; IAPALL flag=1
MOV    IAPCON, #47h      ; IAPWE flag=1, one-byte write
                                ; Flash IAP write enable if IAPALL=IAPWE=1
MOVX   @DPTR, A          ; IAP Write Flash
                                ; Flash[1F00h] =5Ah after IAP write
MOVX   @DPTR, A          ; IAP Write Flash twice
MOV    IAPCON, #00h      ; IAP write disable, immediately after IAP write
ANL    PWRCON, #7Fh      ; IVCPD=0
MOVX   A, @DPTR          ; Read Flash. A=5Ah

```

Two-byte IAP Example: (In BOOT mode)

```

; need 5.0V < VCC < 5.5V & WDT disable
ANL    AUX2, #3Fh        ; Disable WDT
ORL    PWRCON, #80h      ; IVCPD=1
MOV    DPTR, #1F01h      ; DPTR=1F01h mean target IAP address=1F00h~1F01h
                                ; DPTR must be “odd” if user want to use two-byte IAP.
MOV    A, #ABh           ; A=ABh=target IAP write high byte data
MOV    B, #CDh           ; B=CDh=target IAP write low byte data
ORL    AUX2, #04h        ; IAP Time-Out function select
MOV    SWCMD, #65h       ; IAPALL flag=1
MOV    IAPCON, #74h      ; IAPWE flag=1, two-byte write
                                ; Flash IAP write enable if IAPALL=IAPWE=1
MOVX   @DPTR, A          ; IAP Write Flash
                                ; Flash[1F00h] =5Ah after IAP write
MOVX   @DPTR, A          ; IAP Write Flash twice
MOV    IAPCON, #00h      ; IAP write disable, immediately after IAP write
ANL    PWRCON, #7Fh      ; IVCPD=0
MOVX   A, @DPTR          ; Read Flash. A=ABh

```

MOV DPTR, #1F00h ;  
 MOVX A, @DPTR ; Read Flash. A=CDh

SFR 97h	Bit 7	Bit 6	Bit 5	Bit 4	Bit 3	Bit 2	Bit 1	Bit 0
<b>SWCMD</b>	IAPALL/SWRST							
R/W	W							
Reset	-							

97h.7~0 **IAPALL (W):**  
 Write 65h to set IAPALL flag. Write other value to clear IAPALL flag.

SFR 97h	Bit 7	Bit 6	Bit 5	Bit 4	Bit 3	Bit 2	Bit 1	Bit 0
<b>SWCMD</b>	-						WDTO	IAPALL
R/W	R						R	R
Reset	0						0	0

97h.0 **IAPALL (R):** Flag indicates Flash can be written by IAP or not  
 0: Flash IAP disable  
 1: Flash IAP enable, only for BOOT mode upgrade APP area.

SFR C9h	Bit 7	Bit 6	Bit 5	Bit 4	Bit 3	Bit 2	Bit 1	Bit 0
<b>IAPCON</b>	IAPCON							
R/W	W							
Reset	-	-	-	-	-	-	-	-

C9h.7~0 **IAPCON (W):**  
 Write 47h or 74h to set IAPWE flag; Write 47h can write 1 byte at once, write 74h can write 2 bytes at once. Write other value to clear IAPWE flag. It is recommended to clear it immediately after IAP write.  
 Write A1h to set INFOWE flag; write other value to clear INFOWE flag. It is recommended to clear it immediately after IAP write.  
 Write E2h to set EEPWE flag; write other value to clear EEPWE flag. It is recommended to clear it immediately after EEPROM write.

SFR C9h	Bit 7	Bit 6	Bit 5	Bit 4	Bit 3	Bit 2	Bit 1	Bit 0
<b>IAPCON</b>	IAPWE	IAPTO	EEPWE	INFOWE	-	-	-	-
R/W	R	R	R	R	-	-	-	-
Reset	0	0	0	0	-	-	-	-

C9h.7 **IAPWE (R):** Flag indicates Flash memory can be written by IAP or not  
 0: IAP Write disable  
 1: IAP Write enable

C9h.6 **IAPTO (R):** Time-Out flag of IAP write/EEPROM write/INFO write. Set by H/W when IAP or EEPROM write or INFO write Time-out occurs. Cleared this flag by H/W when IAPWE=0 or EEPWE=0 or INFOWE=0.

SFR F7h	Bit 7	Bit 6	Bit 5	Bit 4	Bit 3	Bit 2	Bit 1	Bit 0
<b>AUX2</b>	WDTE		PWRSVAV	VBGOUT	DIV32	IAPTE		MULDIV16
R/W	R/W	R/W	R/W	R/W	R/W	R/W		R/W
Reset	0	0	0	0	0	1	1	0

F7h.7~6 **WDTE:** Watchdog Timer Reset control  
 0x: Watchdog Timer Reset disable  
 10: Watchdog Timer Reset enable in Fast/Slow mode, disable in Idle/Halt/Stop mode  
 11: Watchdog Timer Reset always enable

F7h.2~1 **IAPTE:** IAP (or EEPROM) write watchdog timer enable  
 00: Disable

- 01: wait 1.6ms trigger watchdog time-out flag, and escape the write fail state
- 10: wait 3.1ms trigger watchdog time-out flag, and escape the write fail state
- 11: wait 12.5ms trigger watchdog time-out flag, and escape the write fail state

### 2.1.3 Flash ICP Mode

The Flash memory can be programmed by the tenx writer, which needs at least four wires (VCC, VSS, P3.0 and P3.1) to connect to this chip. If user wants to program the Flash memory on the target circuit board (In Circuit Program, ICP), these pins must be reserved sufficient freedom to be connected to the Writer.

### 2.1.4 Flash ISP Mode

The “In System Programming” (ISP) usage is similar to IAP, except the purpose is to refresh the Program code. User can use UART or other method to get new Program code from external host, then writes code as the same way as IAP. ISP operation is complicated; basically it needs to assign a Boot code area to the Flash which does not change during the ISP process.

## 2.2 Information Memory (Support IAP)

The Chip has a 64 bytes Information memory. The Information memory address continuous space (E500h~E53Fh) is partitioned to several sectors for device operation.

Chip Info area is tenx reserved defined as production information, such as ID, Special Regulations, Code Num, checksum. BOOT Info area allow IAP write in BOOT mode, user can store new checksum code in this area after Flash IAP.

The IVC function must be turned off when writing to the Information memory.

To use IAP function, user need to meet the following conditions:

1. In BOOT mode.
2. Only BOOT Info Area can be written by IAP.
3. Set INFOWE=1.

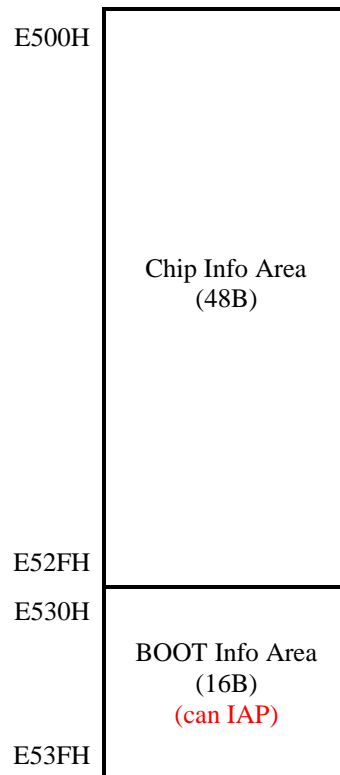

**Info ROM partition**

**Info ROM IAP Write** is simply achieved by a “MOVX @DPTR, A” instruction while the DPTR contains the target Flash address, and the ACC contains the data being written. Flash writing requires approximately 0.6 ms @V<sub>CC</sub>=4.0V~5.5V, VCC capacitance greater than 220uF. During the period of IAP, the CPU stays in a waiting state, but all peripheral modules continue running during the writing time. The software must handle the pending interrupts after an IAP write. The chip has a build-in write Time-out function selected by IAPTE(F7h.2~1) to escape write fail state. Besides, S/W must disable WDT before IAP write.



**Info ROM IAP Read** only can be performed by the “MOVX” instruction as long as the target address points to the E500h~E53Fh area. A Info ROM IAP read does not require extra CPU wait time.

Info ROM IAP Example: (In BOOT mode)

; need 4.0V < V<sub>CC</sub> < 5.5V & WDT disable

```

ANL    AUX2, #3Fh      ; Disable WDT
ORL    PWRCON, #80h    ; IVCPD=1
MOV    DPTR, #E530h    ; DPTR=E530h=target IAP address
MOV    A, #5Ah         ; A=5Ah=target IAP write data
ORL    AUX2, #04h     ; IAP Time-Out function select
MOV    IAPCON, #A1h   ; Info ROM IAP write enable.
MOVX   @DPTR, A        ; IAP Write Info ROM
                          ; Info ROM[E530h] =5Ah after IAP write
MOVX   @DPTR, A        IAP Write Info ROM twice
MOV    IAPCON, #00h   ; IAP write disable, immediately after IAP write
ANL    PWRCON, #7Fh   ; IVCPD=0
MOVX   A, @DPTR       ; Read Info ROM. A=5Ah
    
```

SFR C9h	Bit 7	Bit 6	Bit 5	Bit 4	Bit 3	Bit 2	Bit 1	Bit 0
<b>IAPCON</b>	IAPCON							
R/W	W							
Reset	–	–	–	–	–	–	–	–

C9h.7~0 **IAPCON (W):**

Write 47h or 74h to set IAPWE flag; Write 47h can write 1 byte at once, write 74h can write 2 bytes at once. Write other value to clear IAPWE flag. It is recommended to clear it immediately after IAP write.

Write A1h to set INFOWE flag; write other value to clear INFOWE flag. It is recommended to clear it immediately after IAP write.

Write E2h to set EEPWE flag; write other value to clear EEPWE flag. It is recommended to clear it immediately after EEPROM write.

SFR C9h	Bit 7	Bit 6	Bit 5	Bit 4	Bit 3	Bit 2	Bit 1	Bit 0
<b>IAPCON</b>	IAPWE	IAPTO	EEPWE	INFOWE	–	–	–	–
R/W	R	R	R	R	–	–	–	–
Reset	0	0	0	0	–	–	–	–

C9h.6 **IAPTO (R):** Time-Out flag of IAP write/EEPROM write/INFO write. Set by H/W when IAP or EEPROM write or INFO write Time-out occurs. Cleared this flag by H/W when IAPWE=0 or EEPWE=0 or INFOWE=0.

C9h.4 **INFOWE (R):** Flag indicates INFO memory can be written by IAP or not

0: INFO IAP Write disable

1: INFO IAP Write enable

SFR F7h	Bit 7	Bit 6	Bit 5	Bit 4	Bit 3	Bit 2	Bit 1	Bit 0
<b>AUX2</b>	WDTE		PWRSAV	VBGOUT	DIV32	IAPTE		MULDIV16
R/W	R/W	R/W	R/W	R/W	R/W	R/W		R/W
Reset	0	0	0	0	0	1	1	0

F7h.7~6 **WDTE:** Watchdog Timer Reset control

0x: Watchdog Timer Reset disable



10: Watchdog Timer Reset enable in Fast/Slow mode, disable in Idle/Halt/Stop mode  
11: Watchdog Timer Reset always enable

F7h.2~1 **IAPTE:** IAP write/EEPROM write/INFO write watchdog timer enable

00: Disable

01: wait 1.6ms trigger watchdog time-out flag, and escape the write fail state

10: wait 3.1ms trigger watchdog time-out flag, and escape the write fail state

11: wait 12.5ms trigger watchdog time-out flag, and escape the write fail state

### 2.3 EEPROM Memory

The chip contains 128 bytes of data EEPROM memory. It is organized as a separate data space, in which single bytes can be read and written. The EEPROM has an endurance of at least 50K write/erase cycles.

<b>EEPROM Memory</b>	
EE00h	EEPROM[0]
EE02h	EEPROM[1]
EE04h	.
	.
	.
EEFCh	EEPROM[126]
EEFEh	EEPROM[127]

**(Only even addresses can be used, odd addresses are invalid)**

**The EEPROM Write** usage is similar to Flash IAP mode. It is simply achieved by a “MOVX @DPTR, A” instruction while the DPTR contains the target EEPROM address, and the ACC contains the data being written. EEPROM writing requires approximately 0.6 ms @V<sub>CC</sub>=3.5V~5.5V, VCC capacitance greater than 220uF. When the EEPROM is being written, the CPU stays in a waiting state, but all peripheral modules (Timers, LED, and others) continue running during the writing time. The software must handle the pending interrupts after an EEPROM write. The chip has a build-in EEPROM Time-out function shared with Flash IAP for escaping write fail state. The chip has a build-in write Time-out function selected by IAPTE (F7h.2~1) to escape write fail state. Besides, S/W must disable WDT before EEPROM write.

The IVC function must be turned off when writing to the EEPROM.

**The EEPROM Read** can be performed by the “MOVX A, @DPTR” instruction as long as the target address points to the EE00h~EEFEh area.

EEPROM example code:

```

; need 3.5V < VDD < 5.5V & WDT disable
ANL     AUX2, #3Fh           ; Disable WDT
ORL     PWRCON, #80h        ; IVC PD=1
MOV     DPTR, #EE00h        ; DPTR=EE00h=target EEPROM[0] address
MOV     A, #A5h             ; A=A5h=target EEPROM[0] write data
ORL     AUX2, #04h          ; IAP Time-Out function select.
MOV     IAPCON, #E2h        ; EEPROM write enable
MOVX    @DPTR, A            ; Write EEPROM.
MOV     IAPCON, #00h        ; EEPROM write disable, immediately after EEPROM write
ANL     PWRCON, #7Fh        ; IVC PD=0
MOVX    A, @DPTR            ; Read EEPROM. A=A5h.

```

SFR C9h	Bit 7	Bit 6	Bit 5	Bit 4	Bit 3	Bit 2	Bit 1	Bit 0
<b>IAPCON</b>	IAPCON							
R/W	W							
Reset	-	-	-	-	-	-	-	-

**C9h.7~0 IAPCON (W):**

Write 47h or 74h to set IAPWE flag; Write 47h can write 1 byte at once, write 74h can write 2 bytes at once. Write other value to clear IAPWE flag. It is recommended to clear it immediately after IAP write.

Write A1h to set INFOWE flag; write other value to clear INFOWE flag. It is recommended to clear it immediately after IAP write.

Write E2h to set EEPWE flag; write other value to clear EEPWE flag. It is recommended to clear it immediately after EEPROM write.

SFR C9h	Bit 7	Bit 6	Bit 5	Bit 4	Bit 3	Bit 2	Bit 1	Bit 0
<b>IAPCON</b>	IAPWE	IAPTO	EEPWE	INFOWE	-	-	-	-
R/W	R	R	R	R	-	-	-	-
Reset	0	0	0	0	-	-	-	-

**C9h.6 IAPTO (R):** Time-Out flag of IAP write/EEPROM write/INFO write. Set by H/W when IAP or EEPROM write or INFO write Time-out occurs. Cleared this flag by H/W when IAPWE=0 or EEPWE=0 or INFOWE=0.

**C9h.5 EEPWE (R):** Flag indicates EEPROM can be written or not  
 0: EEPROM Write disable  
 1: EEPROM Write enable

SFR F7h	Bit 7	Bit 6	Bit 5	Bit 4	Bit 3	Bit 2	Bit 1	Bit 0
<b>AUX2</b>	WDTE		PWRSAV	VBGOUT	DIV32	IAPTE		MULDIV16
R/W	R/W	R/W	R/W	R/W	R/W	R/W		R/W
Reset	0	0	0	0	0	1	1	0

**F7h.7~6 WDTE:** Watchdog Timer Reset control

0x: Watchdog Timer Reset disable

10: Watchdog Timer Reset enable in Fast/Slow mode, disable in Idle/Halt/Stop mode

11: Watchdog Timer Reset always enable

**F7h.2~1 IAPTE:** IAP write/EEPROM write/INFO write watchdog timer enable

00: Disable

01: wait 1.6ms trigger watchdog time-out flag, and escape the write fail state

10: wait 3.1ms trigger watchdog time-out flag, and escape the write fail state

11: wait 12.5ms trigger watchdog time-out flag, and escape the write fail state

### 2.4 IRAM

IRAM is located in the 8051 internal data memory space. The whole 256 Bytes IRAM are accessible using indirect addressing but only the lower 128 Bytes are accessible using direct addressing. There are four directly addressable register banks (switching by PSW), which occupy IRAM space from 00h to 1Fh. The address 20h to 2Fh 16 Bytes IRAM space is bit-addressable. IRAM can be used as scratch pad registers or program stack.

### 2.5 XRAM

XRAM is located in the 8051 external data memory space (address from FD00h to FFFFh). The 768 bytes XRAM can be only accessed by “MOVX” instruction.

### 2.6 Special Function Register (SFR)

All peripheral functional modules such as I/O ports, Timers and UART operations for the chip are accessed via Special Function Registers (SFRs). These registers occupy upper 128 Bytes of direct Data Memory space locations in the range 80h to FFh. There are 14 bit-addressable SFRs (which means that eight individual bits inside a single byte are addressable), such as ACC, B register, PSW, TCON, SCON, and others. The remaining SFRs are only byte addressable. SFRs provide control and data exchange with the resources and peripherals of the Chip. The TM52 series of microcontrollers provides complete binary code with standard 8051 instruction set compatibility. Beside the standard 8051 SFRs, the Chip implements additional SFRs used to configure and access subsystems such as the ADC/LCD, which are unique to the Chip.

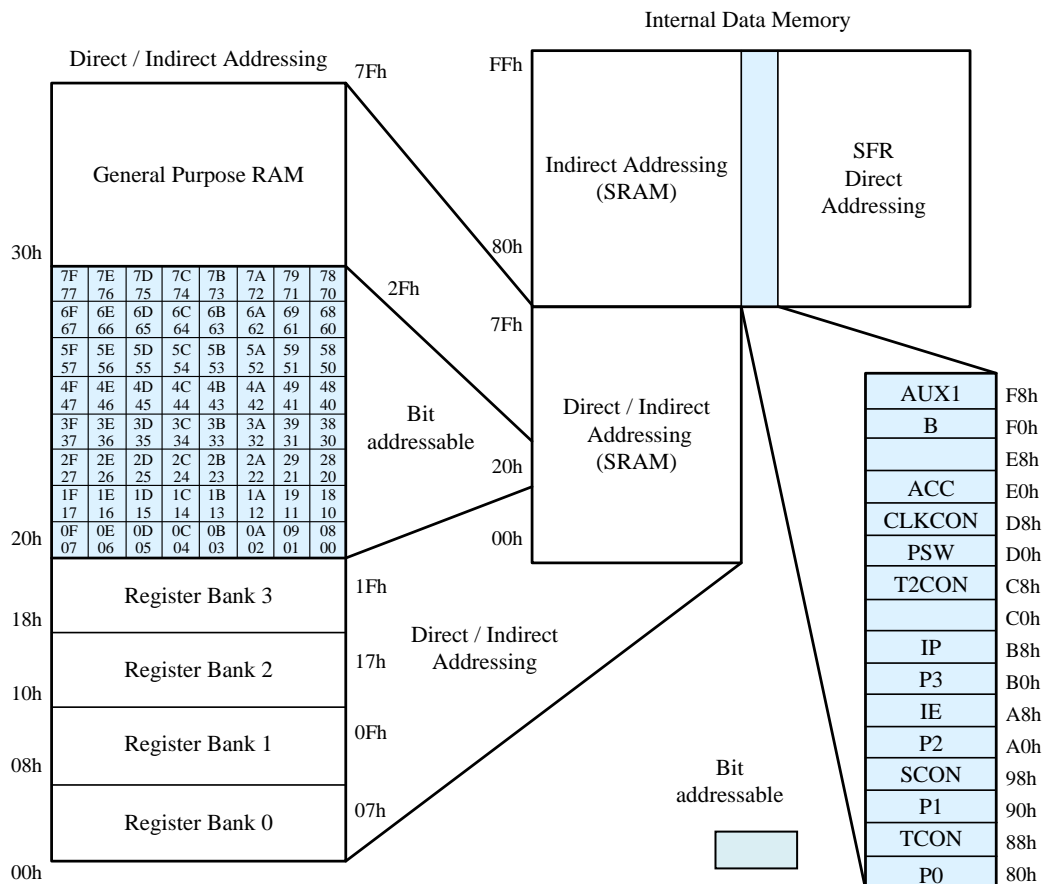

	8/0	9/1	A/2	B/3	C/4	D/5	E/6	F/7
F8h	AUX1							
F0h	B	CRCDL	CRCDH	CRCIN		CFGBG	CFGWL	AUX2
E8h		PWM4DH	PWM4DL	PWM5DH	PWM5DL	PWM6DH	PWM6DL	PWRCON
E0h	ACC	MICON	MIDAT	LVRCON	LVDCON	EFTCON	EXA	EXB
D8h	CLKCON	PWM0PRDH	PWM0PRDL	PWM1PRDH	PWM1PRDL	PWM3DH	PWM3DL	UARTCON
D0h	PSW	PWM0DH	PWM0DL	PWM1DH	PWM1DL	PWM2DH	PWM2DL	CFGOP
C8h	T2CON	IAPCON	RCP2L	RCP2H	TL2	TH2	EXA2	EXA3
C0h		TKBTMRL	TKBTMRH	TKBKCP	TKBREFC	P0WKUP	P2WKUP	P3WKUP
B8h	IP	IPH	IP1	IP1H	SPCON	SPSTA	SPDAT	BOOTV
B0h	P3	TKAREFC	TKADH	TKCHS	TKATMRL	TKATMRH	PWMOE1	PWMOE2
A8h	IE	INTE1	ADCDL	ADCDH	TKADL	TKCON	CHSEL	PILOE
A0h	P2	PWMCON	P1MODL	P1MODH	P3MODL	P3MODH	PWMOE0	PWMCON2
98h	SCON	SBUF	WGCON	WGCON2	DACON	CMPCON	CMPPNS	OPCON
90h	P1	P0MODL	P0MODH	PINMOD	OPTION	INTFLG	P1WKUP	SWCMD
88h	TCON	TMOD	TL0	TL1	TH0	TH1	TKBDL	TKBDH
80h	P0	SP	DPL	DPH	INTE2	INTFLG2	DACON2	PCON

**SFR table**

### 3. Reset

The chip has five types of reset (Reset) methods. Power-on reset (POR), external pin reset (XRST), software reset (SWRST), watchdog timer reset (WDTR) and low voltage reset (LVR), SFR returns to default values after reset.

After reset, the Program memory address will start at 0000h, 3000h or 3800h depended by RSTV (BFh.2) and CFGH.3~2.

#### 3.1 Power on Reset (POR)

After power-on reset, the device stays in the reset state and the preheating time of this chip is about 40ms. A power-on reset requires the voltage on the VCC pin to discharge to near the VSS level before rising above 2.2V(TBD). POR is automatically turned off when the chip enters HALT/STOP mode and can be enabled or disabled by PORPD (E3h.5) when the chip is not in HALT/STOP mode.

#### 3.2 External Pin Reset (XRST)

External Pin Reset is active low. It needs to keep at least 2 SRC clock cycle long to be seen by the Chip. External Pin Reset can be enabled or disabled by CFGWH.6.

#### 3.3 Software Command Reset (SWRST)

Software reset is generated by writing data 56h to SWCMD (97h).

#### 3.4 Watchdog Timer Reset (WDTR)

WDT overflow reset is controlled by WDTE (F7h.7~6). The WDT uses SRC as the count time base, runs in FAST/SLOW clock mode, and optionally runs or stops in IDLE/HALT/STOP clock mode. The watchdog timer overflow speed can be defined by WDTOSC (94h.5~4). WDT is cleared by CLRWDT (F8h.7) or reset.

#### 3.5 Low Voltage Reset (LVR)

Low voltage reset (LVR) can select 16 different voltage thresholds through LVRCON (E3h.3~0). When PWRSAV (F7h.5) =1, the LVR will automatically turn off when the chip enters IDLE/HALT/STOP mode. It can be enabled or disabled by LVRPD (E3h.4).

*Note: refer to AP-TM52XXXXX\_02S for LVR setting information*

Operation Mode	SFR		CFGWH	LVR	Function	Note
	LVRPD	PWRSVAV	LVRE			
Fast Slow	0	X	0000	ON	LVR 2.05V	
	0	X	0001	ON	LVR 2.19V	
	0	X	0010	ON	LVR 2.33V	
	0	X	0011	ON	LVR 2.47V	
	0	X	0100	ON	LVR 2.61V	
	0	X	0101	ON	LVR 2.75V	
	0	X	0110	ON	LVR 2.89V	
	0	X	0111	ON	LVR 3.03V	
	0	X	1000	ON	LVR 3.17V	
	0	X	1001	ON	LVR 3.31V	
	0	X	1010	ON	LVR 3.45V	
	0	X	1011	ON	LVR 3.59V	
	0	X	1100	ON	LVR 3.73V	
	0	X	1101	ON	LVR 3.87V	
	0	X	1110	ON	LVR 4.01V	
0	X	1111	ON	LVR 4.15V		
Idle Halt Stop	0	0	0000	ON	LVR 2.05V	Current consumption about 60uA(TBD)
	0	0	0001	ON	LVR 2.19V	
	0	0	0010	ON	LVR 2.33V	
	0	0	0011	ON	LVR 2.47V	
	0	0	0100	ON	LVR 2.61V	
	0	0	0101	ON	LVR 2.75V	
	0	0	0110	ON	LVR 2.89V	
	0	0	0111	ON	LVR 3.03V	
	0	0	1000	ON	LVR 3.17V	
	0	0	1001	ON	LVR 3.31V	
	0	0	1010	ON	LVR 3.45V	
	0	0	1011	ON	LVR 3.59V	
	0	0	1100	ON	LVR 3.73V	
	0	0	1101	ON	LVR 3.87V	
	0	0	1110	ON	LVR 4.01V	
0	0	1111	ON	LVR 4.15V		
Idle	0	1	XXXX	ON	Disable LVR Enable POR	Current consumption about 20uA(TBD)
Halt Stop	0	1	XXXX	OFF	Disable	Minimum current consumption about 0.1uA
Fast Slow Idle	1	X	XXXX	ON	Disable LVR Enable POR	Current consumption about 20uA(TBD)
Halt Stop	1	X	XXXX	OFF	Disable	Minimum current consumption about 0.1uA

**Note:** The current consumption of Halt mode is more than STOP mode about 2 ~ 5uA, because SRC is enabled.



SFR 94h	Bit 7	Bit 6	Bit 5	Bit 4	Bit 3	Bit 2	Bit 1	Bit 0
<b>OPTION</b>	UART1W	TM3CKS	WDTPSC		ADCKS		TM3PSC	
R/W	R/W	R/W	R/W		R/W		R/W	
Reset	0	0	0	0	0	0	0	0

94h.5~4 **WDTPSC:** Watchdog Timer pre-scalar time select.  
 00: 400ms WDT overflow rate  
 01: 200ms WDT overflow rate  
 10: 100ms WDT overflow rate  
 11: 50ms WDT overflow rate

SFR 97h	Bit 7	Bit 6	Bit 5	Bit 4	Bit 3	Bit 2	Bit 1	Bit 0
<b>SWCMD</b>	IAPALL/SWRST							
R/W	W							
Reset	-							

97h.7~0 **SWRST:** Write 56h to generate S/W Reset

SFR E3h	Bit 7	Bit 6	Bit 5	Bit 4	Bit 3	Bit 2	Bit 1	Bit 0
<b>LVRCON</b>	-	-	PORPD	LVRPD	LVRSEL			
R/W	-	-	R/W	R/W	R/W	R/W	R/W	R/W
Reset	-	-	0	0	0	0	0	0

E3h.5 **PORPD:** POR Power Down.  
 0: POR Enable, 1: POR Disable

E3h.4 **LVRPD:** LVR Power Down.  
 0: LVR Enable, 1: LVR Disable

E3h.3~0 **LVRSEL:** Low Voltage Reset function select.  
 0000: Set LVR at 2.05V  
 0001: Set LVR at 2.19V  
 0010: Set LVR at 2.33V  
 0011: Set LVR at 2.47V  
 0100: Set LVR at 2.61V  
 0101: Set LVR at 2.75V  
 0110: Set LVR at 2.89V  
 0111: Set LVR at 3.03V  
 1000: Set LVR at 3.17V  
 1001: Set LVR at 3.31V  
 1010: Set LVR at 3.45V  
 1011: Set LVR at 3.59V  
 1100: Set LVR at 3.73V  
 1101: Set LVR at 3.87V  
 1110: Set LVR at 4.01V  
 1111: Set LVR at 4.15V

SFR F7h	Bit 7	Bit 6	Bit 5	Bit 4	Bit 3	Bit 2	Bit 1	Bit 0
<b>AUX2</b>	WDTE		PWRSAB	VBGOUT	DIV32	IAPTE		MULDIV16
R/W	R/W	R/W	R/W	R/W	R/W	R/W		R/W
Reset	0	0	0	0	0	1	1	0

F7h.7~6 **WDTE:** Watchdog Timer Reset control  
 0x: Watchdog Timer Reset disable  
 10: Watchdog Timer Reset enable in Fast/Slow mode, disable in Idle/Halt/Stop mode  
 11: Watchdog Timer Reset always enable

F7h.5 **PWRSAB:** chip power-saving option  
 Set 1 to reduce the chip's power consumption at Idle/Halt/Stop Mode

SFR F8h	Bit 7	Bit 6	Bit 5	Bit 4	Bit 3	Bit 2	Bit 1	Bit 0
<b>AUX1</b>	CLRWDT	CLRTM3	–	ADSOC	CLRPWM0	CLRPWM1	LDOCOUT	DPSEL
R/W	R/W	R/W	–	R/W	R/W	R/W	R/W	R/W
Reset	0	0	–	0	1	1	0	0

F8h.7 **CLRWDT:** Set to clear WDT, H/W auto clear it at next clock cycle

## 4. Clock Circuitry & Operation Mode

### 4.1 System Clock

The Chip is designed with dual-clock system. During runtime, user can directly switch the System clock from fast to slow or from slow to fast. It also can directly select a clock divider of 1, 2, 4 or 16. The Fast clock can be selected as FRC (Fast Internal RC, 16.588 MHz). The Slow clock can be selected as SRC (Slow Internal RC, 32 KHz). Fast mode and Slow mode are defined as the CPU running at Fast and Slow clock speeds.

After Reset, the device is running at Slow mode with 32 KHz SRC. S/W should select the proper clock rate for chip operation safety. The higher  $V_{CC}$  allows the chip to run at a higher System clock frequency.

The **CLKCON** SFR controls the System clock operating. H/W automatically blocks the S/W abnormally setting for this register. S/W can only change the Slow clock type in Fast mode and change the Fast clock type in Slow mode. Never to write both **STPFCK=1** & **SELFCK=1**. It is recommended to write this SFR bit by bit.

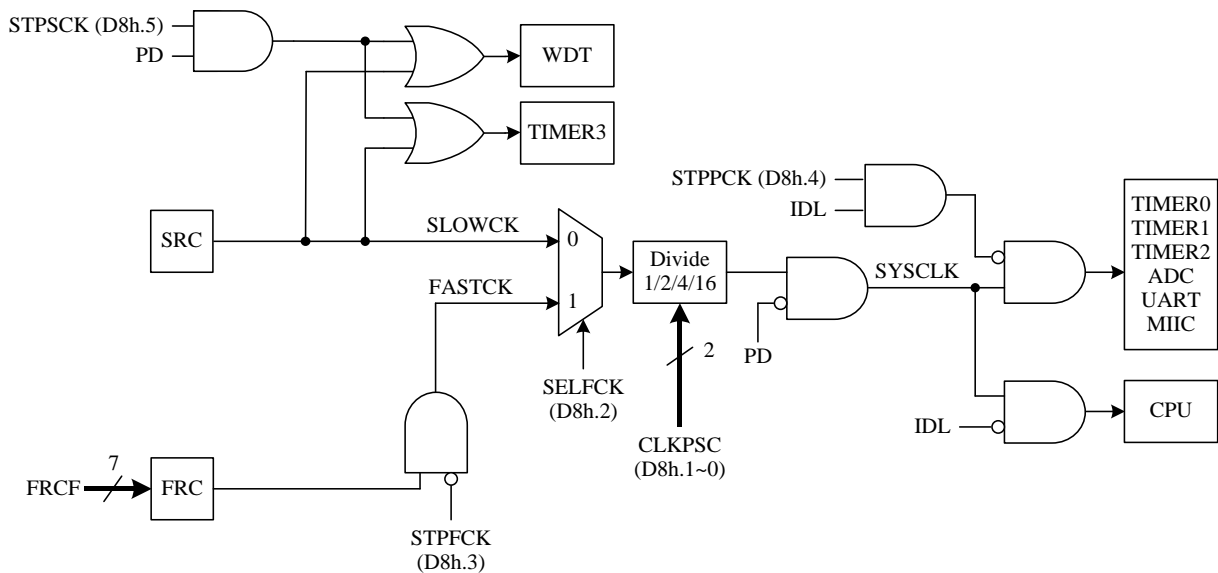

**Clock Structure**

**Note:** Because of the **CLKPSC** delay, it needs to wait for 16 clock cycles (max.) before switching Slow clock to Fast clock. Also refer to **AP-TM52XXXXX\_01S** and **AP-TM52XXXXX\_02S** about System Clock Application Note.

SYSCLK	CLKCON (D8h)	
	bit3 STPFCK	bit2 SELFCK
Fast FRC	0	1
Slow SRC	0/1	0
Stop FRC	0 → 1	0
Switch to FRC	0	0 → 1
Switch to SRC	0	1 → 0

Flash 1FFDh	Bit 7	Bit 6	Bit 5	Bit 4	Bit 3	Bit 2	Bit 1	Bit 0
<b>CFGWL</b>	–	FRCF						

1FFDh.6~0 **FRCF**: FRC frequency adjustment.

FRC is trimmed to 16.588 MHz in chip manufacturing. FRCF records the adjustment data.

SFR F6h	Bit 7	Bit 6	Bit 5	Bit 4	Bit 3	Bit 2	Bit 1	Bit 0
<b>CFGWL</b>	–	FRCF						
R/W	–	R/W						
Reset	–	–	–	–	–	–	–	–

F6h.6~0 **FRCF**: FRC frequency adjustment

00h= lowest frequency, 7Fh=highest frequency.

SFR D8h	Bit 7	Bit 6	Bit 5	Bit 4	Bit 3	Bit 2	Bit 1	Bit 0
<b>CLKCON</b>	–	–	STPSCK	STPPCK	STPFCK	SELFCK	CLKPSC	
R/W	–	–	R/W	R/W	R/W	R/W	R/W	
Reset	–	–	0	0	0	0	1	1

D8h.5 **STPSCK**: Set 1 to stop slow clock in Stop mode.

D8h.4 **STPPCK**: Set 1 to stop UARTs/Timer0/Timer1/Timer2/ADC clock in Idle mode for current reducing. If set, only Timer3 and pin interrupts are alive in Idle Mode.

D8h.3 **STPFCK**: Set 1 to stop Fast clock for power saving in Slow/Idle mode. This bit can be changed only in Slow mode.

D8h.2 **SELFCK**: System clock source selection. This bit can be changed only when STPFCK=0.  
 0: Slow clock  
 1: Fast clock

D8h.1~0 **CLKPSC**: System clock prescaler. Effective after 16 clock cycles (Max.) delay.

00: System clock is Fast/Slow clock divided by 16

01: System clock is Fast/Slow clock divided by 4

10: System clock is Fast/Slow clock divided by 2

11: System clock is Fast/Slow clock divided by 1

## 4.2 Operation Modes

There are 5 operation modes for this device. The power consumption is lower when the system clock speed is lower.

### Fast Mode:

Fast Mode is defined as the CPU running at Fast clock speed.

### Slow Mode:

Slow Mode is defined as the CPU running at Slow clock speed.

### Idle Mode:

Idle Mode is entered by setting the **IDL** bit in PCON SFR.

Both Fast and Slow clock can be set as the System clock source in Idle Mode, but Slow clock is better for power saving. In Idle mode, the CPU puts itself to sleep while the on-chip peripherals stay active. The “STPPCK” bit in CLKCON SFR can be set to furthermore reduce Idle mode current. If STPPCK is set, only Timer3 and pin interrupts are alive in Idle Mode, others peripherals such as Timer0/1/2, UARTs and ADC are stop. The slower System clock rate also helps current saving. It can be achieved by setup the CLKPSC SFR to divide System clock frequency. Idle mode is terminated by Reset or Interrupts.

### Halt Mode:

Halt Mode is entered by setting the **PD** bit in PCON SFR and clearing the **STPSCK** bit in CLKCON SFR. In Halt mode, all clocks are stopped, but Timer3 and WDT may be on if they are enabled. Halt mode can be terminated by Reset, Interrupt or Pin wakeup.

### Stop Mode:

Stop Mode is entered by setting the **PD** bit in PCON SFR and setting the **STPSCK** bit in CLKCON SFR.

This mode is the so-called “Power Down” mode in standard 8051. In Stop mode, all clocks stop except the WDT could be alive if it is enabled. Stop Mode is terminated by Reset or Pin wakeup.

*Note: The chip cannot enter Halt/Stop Mode if the INTn pin is low and the INTn wake-up function is enabled. (INTn=0 and EXn=1, n=0,1,2)*

SFR 87h	Bit 7	Bit 6	Bit 5	Bit 4	Bit 3	Bit 2	Bit 1	Bit 0
<b>PCON</b>	SMOD	–	–	–	GF1	GF0	PD	IDL
R/W	R/W	–	–	–	R/W	R/W	R/W	R/W
Reset	0	–	–	–	0	0	0	0

87h.1 **PD:** Power down control bit, set 1 to enter HALT/STOP mode.

87h.0 **IDL:** Idle mode control bit, set 1 to enter IDLE mode.

SFR F7h	Bit 7	Bit 6	Bit 5	Bit 4	Bit 3	Bit 2	Bit 1	Bit 0
<b>AUX2</b>	WDTE		PWRSVAV	VBGOUT	DIV32	IAPTE		MULDIV16
R/W	R/W	R/W	R/W	R/W	R/W	R/W		R/W
Reset	0	0	0	0	0	1	1	0

F7h.4 **VBGOUT:** VBG voltage output to P3.2

0: Disable 1: Enable

SFR D8h	Bit 7	Bit 6	Bit 5	Bit 4	Bit 3	Bit 2	Bit 1	Bit 0
<b>CLKCON</b>	–	–	STPSCK	STPPCK	STPFCK	SELFCK	CLKPSC	
R/W	–	–	R/W	R/W	R/W	R/W	R/W	
Reset	–	–	1	0	0	0	1	1

D8h.5 **STPSCK:** Set 1 to stop Slow clock in Stop mode.

D8h.4 **STPPCK:** Set 1 to stop UART/Timer0/Timer1/Timer2/ADC clock in Idle mode for current reducing. If set, only Timer3 and pin interrupts are alive in Idle Mode.

D8h.3 **STPFCK:** Set 1 to stop Fast clock for power saving in Slow/Idle mode. This bit can be changed only in Slow mode.

D8h.2 **SELFCK:** System clock source selection. This bit can be changed only when STPFCK=0.  
0: Slow clock 1: Fast clock

D8h.1~0 **CLKPSC:** System clock prescaler. Effective after 16 clock cycles (Max.) delay.

00: System clock is Fast/Slow clock divided by 16

01: System clock is Fast/Slow clock divided by 4

10: System clock is Fast/Slow clock divided by 2

11: System clock is Fast/Slow clock divided by 1

### 4.3 IVC (Build-in VDD regulator)

User can set IVC<sub>PD</sub> (EFh.7) = 0 to enable IVC function. it can reduce V<sub>DD</sub> voltage in **Fast mode** or **Slow mode** for power-saving, and be selected different V<sub>DD</sub> voltage by IVC<sub>VS</sub> (EFh.6~5).

User has to set IVC<sub>PD</sub>=1 before going to **Idle mode**, **Halt mode**, or **Stop mode**.

It is only recommended to use IVC<sub>VS</sub>=3 (highest level). Before using IVC, the LVR or LVD must be turned on first, and the user cannot turn off the LVD or LVR when IVC is enabled.

The IVC must be turned off temporarily during writing to Program Memory, Information Memory, or EEPROM.

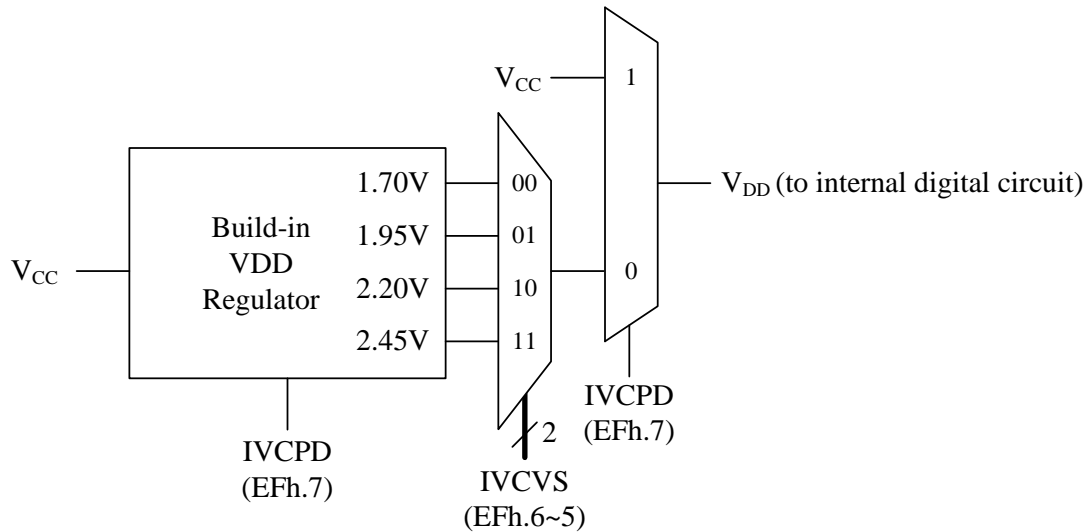

**IVC Schematic**

SFR EFh	Bit 7	Bit 6	Bit 5	Bit 4	Bit 3	Bit 2	Bit 1	Bit 0
<b>PWRCON</b>	IVCPD	IVCVS		–	WARMTIME	–	–	–
R/W	R/W	R/W		–	R/W	–	–	–
Reset	1	1	1	–	0	–	–	–

EFh.7 **IVCPD:** IVC(build-in VDD regulator) power down  
 0: IVC Enable (V<sub>DD</sub> = IVC's voltage)  
 1: IVC Disable (V<sub>DD</sub> = V<sub>CC</sub>)

EFh.6~5 **IVCVS:** IVC Voltage select  
 00: 1.70V  
 01: 1.95V  
 10: 2.20V  
 11: 2.45V (recommended )

*Note: The VCC voltage must be higher than the IVC voltage, when IVC is enabled.*

*Note: F/W must turn on LVR or LVD (LVR<sub>PD</sub>=0 or LVD<sub>PD</sub>=0), when IVC is enabled.*

*Note: F/W must turn off IVC to obtain Tiny Current (IVCPD=1) in Idle/Halt/Stop mode.*

*Note: F/W must turn off IVC (IVCPD=1) before using IAP function.*

### 5. Interrupt & Wake-up

This Chip has a 14-source with 4-level priority interrupt structure. All enabled interrupts can wake up CPU from Idle mode, but only the Pin interrupts (IE0, IE1, IE2, PXIF) and Timer3 (TF3) can wake up CPU from Halt/Stop mode.

Each interrupt source has its own enable control bit. An interrupt event will set its individual interrupt Flag, no matter whether its interrupt enable control bit is 0 or 1. The interrupt vectors and flags are list below.

Vector	Flag	Description
0003	IE0	INT0 external pin interrupt
000B	TF0	Timer0 interrupt
0013	IE1	INT1 external pin interrupt
001B	TF1	Timer1 interrupt
0023	RI+TI	UART interrupt
002B	TF2+EXF2	Timer2 interrupt
0033	–	Reserved for ICE mode
003B	TF3	Timer3 interrupt
0043	PXIF	Port0~Port3 external pin change interrupt
004B	IE2	INT2 external pin interrupt
0053	ADIF / TKIF	ADC interrupt / TK interrupt
005B	SPIF / MIIF	SPI interrupt / Master I <sup>2</sup> C interrupt
0063	LVDIF	LVD interrupt
006B	CMPIF	Comparator interrupt
0073	PWM0IF+PWM1IF	PWM interrupt

**Interrupt vector description**

Vector	Item	Interrupt enable	Sub-interrupt enable	Interrupt flag
0003	IE0	IE A8.0		TCON 88.1
000B	TF0	IE A8.1		TCON 88.5
0013	IE1	IE A8.2		TCON 88.3
001B	TF1	IE A8.3		TCON 88.7
0023	RI+TI	IE A8.4		SCON 98.1~0
002B	TF2+EXF2	IE A8.5		T2CON C8.7~6
0033	–			
003B	TF3	INTE1 A9.0		INTFLG 95.0
0043	PXIF	INTE1 A9.1		INTFLG 95.1
004B	IE2	INTE1 A9.2		INTFLG 95.2
0053	ADIF / TKIF	INTE1 A9.3	INTE2 84.1 INTE2 84.0	INTFLG 95.4 INTFLG 95.5
005B	SPIF / MIIF	INTE1 A9.4		SPSTA BD.7 MICON E1.5
0063	LVDIF	INTE1 A9.5		INTFLG 95.7
006B	CMPIF	INTE1 A9.6		INTFLG 95.6
0073	PWM0IF+PWM1IF	INTE1 A9.7	INTE2 84.6 INTE2 84.5	INTFLG2 85.6 INTFLG2 85.5

**Interrupt related SFRs**



## 5.1 Interrupt Enable and Priority Control

The IE and INTE1 SFRs decide whether the pending interrupt is serviced by CPU. The IP, IPH, IP1 and IP1H SFRs decide the interrupt priority. An interrupt will be serviced as long as an interrupt of equal or higher priority is not already being serviced. If an interrupt of equal or higher level priority is being serviced, the new interrupt will wait until it is finished before being serviced. If a lower priority level interrupt is being serviced, it will be stopped and the new interrupt serviced. When the new interrupt is finished, the lower priority level interrupt that was stopped will be completed.

SFR A8h	Bit 7	Bit 6	Bit 5	Bit 4	Bit 3	Bit 2	Bit 1	Bit 0
<b>IE</b>	EA	–	ET2	ES	ET1	EX1	ET0	EX0
R/W	R/W	–	R/W	R/W	R/W	R/W	R/W	R/W
Reset	0	–	0	0	0	0	0	0

- A8h.7 **EA**: Global interrupt enable control.  
 0: Disable all Interrupts.  
 1: Each interrupt is enabled or disabled by its individual interrupt control bit
- A8h.5 **ET2**: Timer2 interrupt enable  
 0: Disable Timer2 interrupt  
 1: Enable Timer2 interrupt
- A8h.4 **ES**: Serial Port (UART) interrupt enable  
 0: Disable Serial Port (UART) interrupt  
 1: Enable Serial Port (UART) interrupt
- A8h.3 **ET1**: Timer1 interrupt enable  
 0: Disable Timer1 interrupt  
 1: Enable Timer1 interrupt
- A8h.2 **EX1**: External INT1 pin Interrupt enable and Halt/Stop mode wake up enable  
 0: Disable INT1 pin Interrupt and Halt/Stop mode wake up  
 1: Enable INT1 pin Interrupt and Halt/Stop mode wake up, it can wake up CPU from Halt/Stop mode no matter EA is 0 or 1.
- A8h.1 **ET0**: Timer0 interrupt enable  
 0: Disable Timer0 interrupt  
 1: Enable Timer0 interrupt
- A8h.0 **EX0**: External INT0 pin Interrupt enable and Halt/Stop mode wake up enable  
 0: Disable INT0 pin Interrupt and Halt/Stop mode wake up  
 1: Enable INT0 pin Interrupt and Halt/Stop mode wake up, it can wake up CPU from Halt/Stop mode no matter EA is 0 or 1.

SFR A9h	Bit 7	Bit 6	Bit 5	Bit 4	Bit 3	Bit 2	Bit 1	Bit 0
<b>INTE1</b>	PWMIE	CMPIE	LVDIE	SPI2CE	ADTKIE	EX2	PXIE	TM3IE
R/W	R/W	R/W	R/W	R/W	R/W	R/W	R/W	R/W
Reset	0	0	0	0	0	0	0	0

- A9h.7 **PWMIE**: PWM0/PWM1~PWM6 interrupt enable  
 0: Disable PWM0/PWM1~PWM6 interrupt    1: Enable PWM0/PWM1~PWM6 interrupt
- A9h.6 **CMPIE**: CMP interrupt enable  
 0: Disable CMP interrupt    1: Enable CMP interrupt
- A9h.5 **LVDIE**: LVD interrupt enable  
 0: Disable LVD interrupt    1: Enable LVD interrupt
- A9h.4 **SPI2CE**: I<sup>2</sup>C interrupt enable  
 0: Disable SPI/I<sup>2</sup>C interrupt    1: Enable SPI/I<sup>2</sup>C interrupt
- A9h.3 **ADTKIE**: ADC interrupt enable  
 0: Disable ADC/TK interrupt    1: Enable ADC/TK interrupt
- A9h.2 **EX2**: External INT2 pin Interrupt enable and Halt/Stop mode wake up enable

0: Disable INT2 pin Interrupt and Halt/Stop mode wake up  
 1: Enable INT2 pin Interrupt and Halt/Stop mode wake up, it can wake up CPU from Halt/Stop mode no matter EA is 0 or 1.

A9h.1 **PXIE**: Port0~Port3 pin change interrupt enable. This bit does not affect the Port0~Port3 pin's Halt/Stop mode wake up capability.

0: Disable Port0~Port3 pin change interrupt  
 1: Enable Port0~Port3 pin change interrupt

A9h.0 **TM3IE**: Timer3 interrupt enable

0: Disable Timer3 interrupt  
 1: Enable Timer3 interrupt

SFR B9h	Bit 7	Bit 6	Bit 5	Bit 4	Bit 3	Bit 2	Bit 1	Bit 0
<b>IPH</b>	–	–	PT2H	PSH	PT1H	PX1H	PT0H	PX0H
R/W	–	–	R/W	R/W	R/W	R/W	R/W	R/W
Reset	–	–	0	0	0	0	0	0

SFR B8h	Bit 7	Bit 6	Bit 5	Bit 4	Bit 3	Bit 2	Bit 1	Bit 0
<b>IP</b>	–	–	PT2	PS	PT1	PX1	PT0	PX0
R/W	–	–	R/W	R/W	R/W	R/W	R/W	R/W
Reset	–	–	0	0	0	0	0	0

B9h.5, B8h.5 **PT2H, PT2** : Timer2 Interrupt Priority control. (PT2H, PT2) =

11: Level 3 (highest priority)  
 10: Level 2  
 01: Level 1  
 00: Level 0 (lowest priority)

B9h.4, B8h.4 **PSH, PS** : Serial Port (UART) Interrupt Priority control. Definition as above.

B9h.3, B8h.3 **PT1H, PT1** : Timer1 Interrupt Priority control. Definition as above.

B9h.2, B8h.2 **PX1H, PX1** : External INT1 pin Interrupt Priority control. Definition as above.

B9h.1, B8h.1 **PT0H, PT0** : Timer0 Interrupt Priority control. Definition as above.

B9h.0, B8h.0 **PX0H, PX0** : External INT0 pin Interrupt Priority control. Definition as above.

SFR BBh	Bit 7	Bit 6	Bit 5	Bit 4	Bit 3	Bit 2	Bit 1	Bit 0
<b>IP1H</b>	PPWMH	PCMPH	PLVDH	PSPI2CH	PADTKIH	PX2H	PPXH	PT3H
R/W	R/W	R/W	R/W	R/W	R/W	R/W	R/W	R/W
Reset	0	0	0	0	0	0	0	0

SFR BAh	Bit 7	Bit 6	Bit 5	Bit 4	Bit 3	Bit 2	Bit 1	Bit 0
<b>IP1</b>	PPWM	PCMP	PLVD	PSPI2C	PADTKI	PX2	PPX	PT3
R/W	R/W	R/W	R/W	R/W	R/W	R/W	R/W	R/W
Reset	0	0	0	0	0	0	0	0

BBh.7, BAh.7 **PPWMH, PPWM** : PWM0/PWM1 Interrupt Priority control. Definition as above.

BBh.6, BAh.6 **PCMPH, PCMP** : CMP Interrupt Priority control. Definition as above.

BBh.5, BAh.5 **PLVDH, PLVD** : LVD Interrupt Priority control. Definition as above.

BBh.4, BAh.4 **PSPI2CH, PSPI2C** : SPI / I2C Interrupt Priority control. Definition as above.

BBh.3, BAh.3 **PADTKIH, PADTKI** : ADC / TK Interrupt Priority control. Definition as above.

BBh.2, BAh.2 **PX2H, PX2** : External INT2 pin Interrupt Priority control. Definition as above.

BBh.1, BAh.1 **PPXH, PPX** : Port0~Port3 Pin Change Interrupt Priority control. Definition as above.

BBh.0, BAh.0 **PT3H, PT3** : Timer3 Interrupt Priority control. Definition as above.

### 5.2 Pin Interrupt

Pin Interrupts include Change Interrupt. These pins also have the Idle/Halt/Stop mode wake up capability. INT0 and INT1 are falling edge or low level triggered as the 8051 standard. INT2 is falling edge triggered and Port Change Interrupt is triggered by Port pin state change.

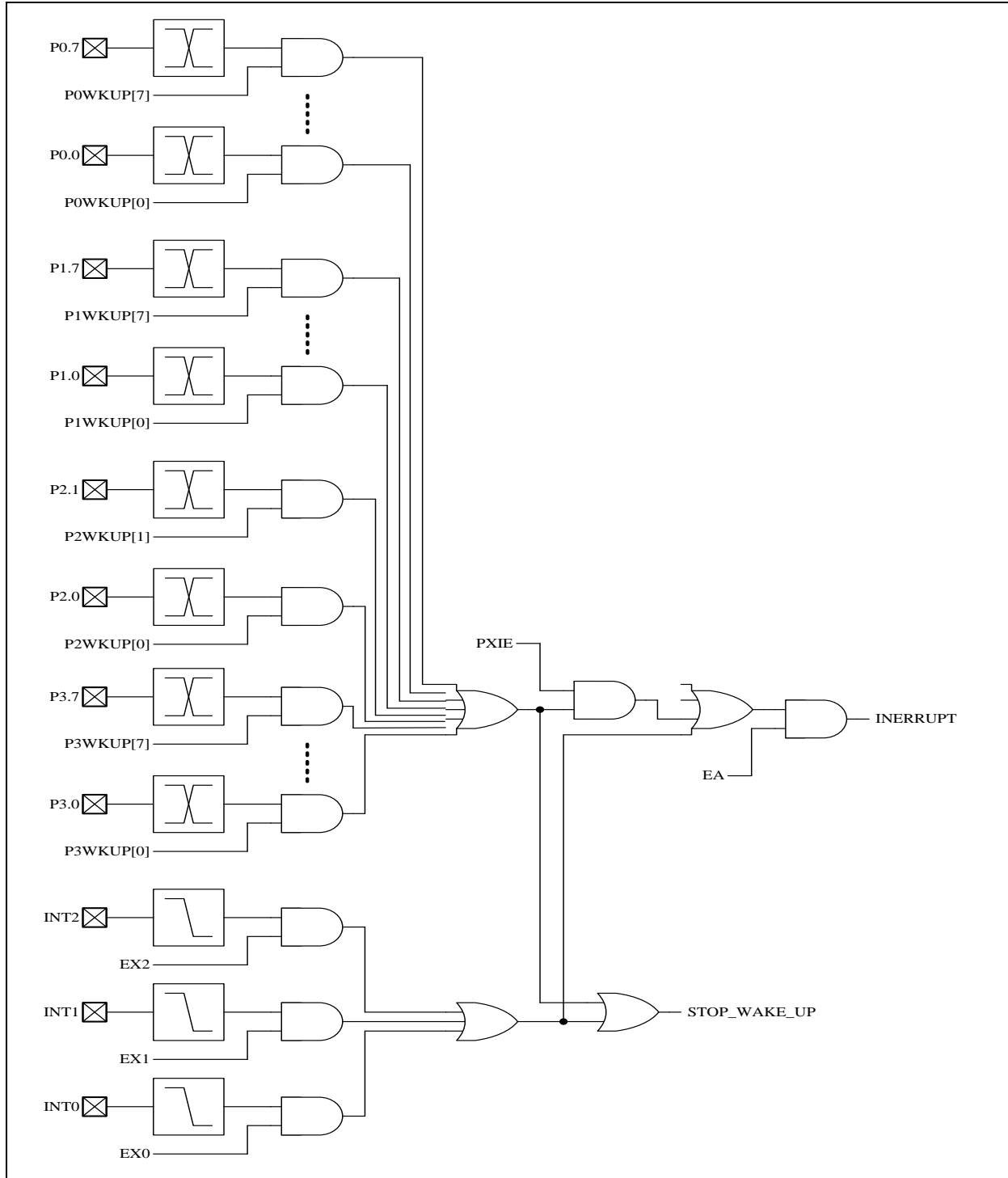

**Pin Interrupt & Wake up**

**Note:** The chip cannot enter Halt/Stop Mode if the INTn pin is low and the INTn wake-up function is enabled. (INTn=0 and EXn=1, n=0~2)

### 5.3 Idle mode Wake up and Interrupt

Each interrupt enable bit (e.g. ET0, EX0) and the EA bit must be set to establish the wake-up function from Idle mode. All enabled interrupts (pins, timers, ADC, touch buttons, SPI and UART) can wake up the CPU from idle mode. When the idle is woken up, immediately enter the interrupt subroutine. When the interrupt subroutine returns, "the first instruction after IDL(PCON.0) is set" will be executed.

For all pin interrupts to be triggered, each interrupt enable bit (e.g. EX0) and the EA bit must be set to 1 and the pin trigger state must stay long enough (greater than 1 system clock) to be sampled by the system clock. When the EA is not set to 1 or the pin trigger state does not stay long enough, it will not wake up and will not generate an interrupt subroutine.

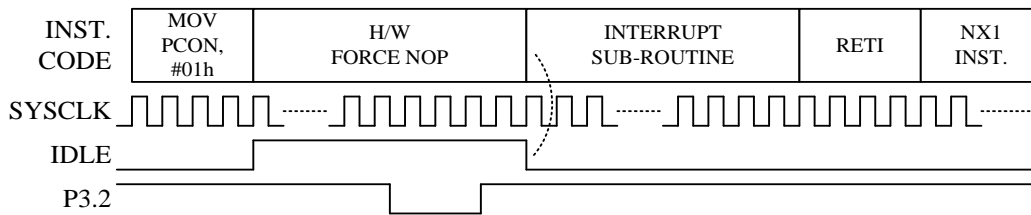

**EA=EX0=1, Idle mode wake-up and Interrupt by P3.2 (INT0)**

SFR 87h	Bit 7	Bit 6	Bit 5	Bit 4	Bit 3	Bit 2	Bit 1	Bit 0
<b>PCON</b>	SMOD	–	–	–	GF1	GF0	PD	IDL
R/W	R/W	–	–	–	R/W	R/W	R/W	R/W
Reset	0	–	–	–	0	0	0	0

87h.1 **PD:** Power down control bit, set 1 to enter HALT/STOP mode.

87h.0 **IDL:** Idle mode control bit, set 1 to enter IDLE mode.

### 5.4 Halt/Stop mode Wake up and Interrupt

Each interrupt enable bit (e.g. ET3, EX0) and the EA bit must be set to 1 to establish the Halt/Stop mode interrupt function. All enabled interrupts (pins, Timer3) can wake up the CPU from Halt/Stop mode. Once Halt/Stop is woken up, if "the first instruction after PD (PCON.1) is set" is a two-cycle instruction, it will execute immediately before the interrupt is serviced, if "the first instruction after PD (PCON.1) is set" is a four-cycle or more long instruction, it will execute after the interrupt is serviced.

In addition to setting EX0/EX1/EX2, the INT0~2 pin interrupt needs to set EA=1 and the pin trigger state stays long enough (greater than 128 system clocks) to be sampled by the system clock, that is to say, when EA is not set to 1 or if the pin trigger state does not stay long enough, the CPU will only wake up without entering the interrupt subroutine.

In addition to setting P0WKUP/P1WKUP/P2WKUP/P3WKUP, Port0~3 WKUP pin interrupt needs to set EA=1, that is to say, when EA is not set to 1, the CPU will only be woken up and will not enter the interrupt subroutine.

*Note:* It is recommended to place the NX1/NX2 with NOP Instruction in figures below.

*Note:* The chip cannot enter Halt/Stop mode if the INTn pin is low and the INTn wake-up function is enabled. (INTn=0 and EXn=1, n=0~2)

**INT0~2 Pin Interrupt:**

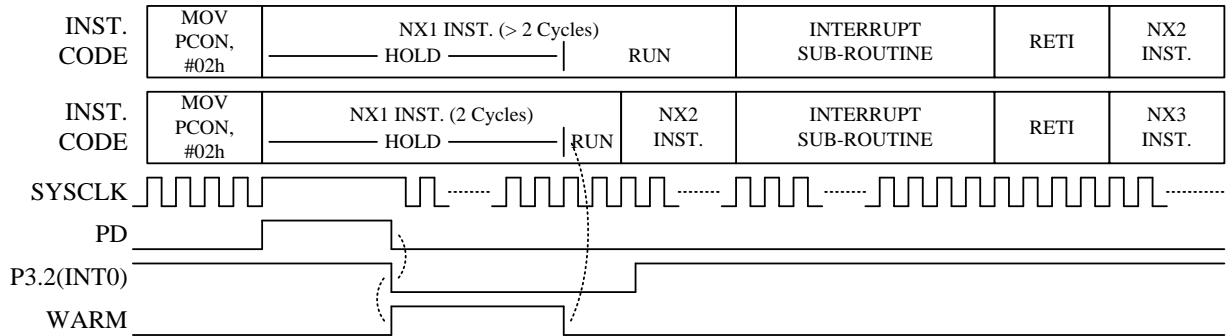

**EA=EX0=1**

**Input the interrupt pulse whose width is greater than 64 system clocks, then the Idle/Stop mode will wake up and enter the interrupt subroutine**

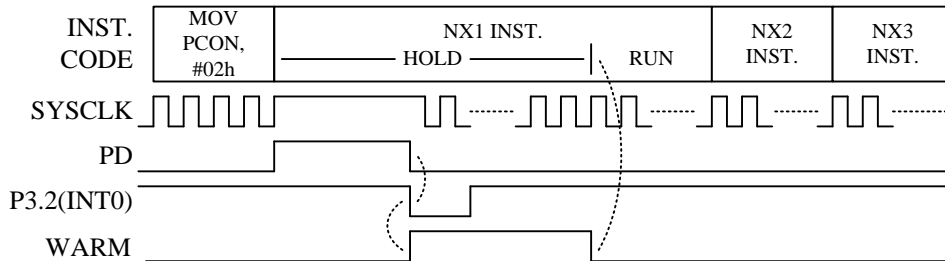

**EA=EX0= 1**

**Input the interrupt pulse whose width is less than 64 system clocks, then the Idle/Stop mode will wake up but will not enter the interrupt subroutine**

**Port0~3 WKUP Pin Interrupt:**

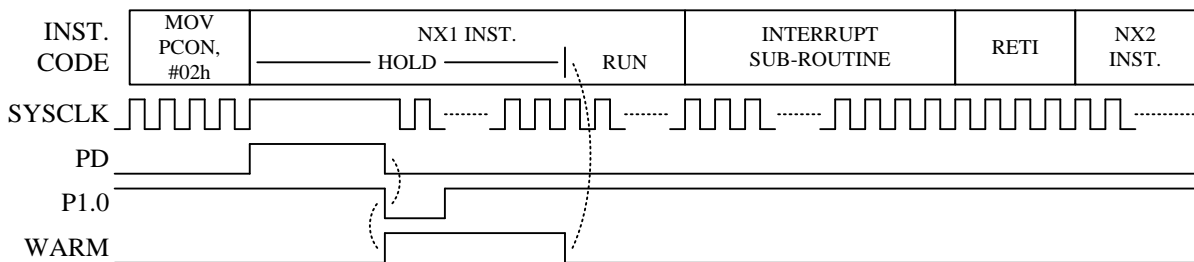

**EA=PXIE=1, P1WKUP[0]=1**

**Input any width WKUP pin interrupt, the Idle/Stop mode will wake up and enter the interrupt subroutine**

SFR 87h	Bit 7	Bit 6	Bit 5	Bit 4	Bit 3	Bit 2	Bit 1	Bit 0
<b>PCON</b>	SMOD	–	–	–	GF1	GF0	PD	IDL
R/W	R/W	–	–	–	R/W	R/W	R/W	R/W
Reset	0	–	–	–	0	0	0	0

87h.1 **PD:** Power down control bit, set 1 to enter HALT/STOP mode.

87h.0 **IDL:** Idle mode control bit, set 1 to enter IDLE mode.

SFR 88h	Bit 7	Bit 6	Bit 5	Bit 4	Bit 3	Bit 2	Bit 1	Bit 0
<b>TCON</b>	TF1	TR1	TF0	TR0	IE1	IT1	IE0	IT0
R/W	R/W	R/W	R/W	R/W	R/W	R/W	R/W	R/W
Reset	0	0	0	0	0	0	0	0

- 88h.3 **IE1:** External Interrupt 1 (INT1 pin) edge flag.  
Set by H/W when an INT1 pin falling edge is detected, no matter the EX1 is 0 or 1.  
It is cleared automatically when the program performs the interrupt service routine.
- 88h.2 **IT1:** External Interrupt 1 control bit  
0: Low level active (level triggered) for INT1 pin  
1: Falling edge active (edge triggered) for INT1 pin
- 88h.1 **IE0:** External Interrupt 0 (INT0 pin) edge flag  
Set by H/W when an INT0 pin falling edge is detected, no matter the EX0 is 0 or 1.  
It is cleared automatically when the program performs the interrupt service routine.
- 88h.0 **IT0:** External Interrupt 0 control bit  
0: Low level active (level triggered) for INT0 pin  
1: Falling edge active (edge triggered) for INT0 pin

SFR 95h	Bit 7	Bit 6	Bit 5	Bit 4	Bit 3	Bit 2	Bit 1	Bit 0
<b>INTFLG</b>	LVDIF	CMPIF	TKIF	ADIF	–	IE2	PXIF	TF3
R/W	R/W	R/W	R/W	R/W	–	R/W	R/W	R/W
Reset	0	0	0	0	–	0	0	0

- 95h.7 **LVDIF:** LVD interrupt flag  
Set by H/W when VCC less than the LVD voltage. S/W writes 7Fh to INTFLG to clear this flag.
- 95h.6 **CMPIF:** CMP interrupt flag  
Set by H/W while CMPO match trigger condition. It is cleared automatically when the program performs the interrupt service routine. S/W writes BFh to INTFLG to clear this flag.
- 95h.5 **TKIF:** Touch Key interrupt flag  
Set by H/W at the end of TK conversion. S/W writes DFh to INTFLG or sets the TKSOC bit to clear this flag. When user clears this flag, H/W will automatically clear TKAIF and TKBIF.
- 95h.4 **ADIF:** ADC interrupt flag  
Set by H/W at the end of ADC conversion. S/W writes EFh to INTFLG or sets the ADSOC bit to clear this flag.
- 95h.2 **IE2:** External Interrupt 2 (INT2 pin) edge flag  
Set by H/W when a falling edge is detected on the INT2 pin, no matter the EX2 is 0 or 1.  
It is cleared automatically when the program performs the interrupt service routine.  
S/W can write FBh to INTFLG to clear this bit.
- 95h.1 **PXIF:** Port0~Port3 pin change interrupt flag  
Set by H/W when Port0~Port3 pin state change is detected and its interrupt enable bit is set (P0WKUP/P1WKUP/P2WKUP/P3WKUP). PXIE does not affect this flag's setting.  
It is cleared automatically when the program performs the interrupt service routine.  
S/W can write FDh to INTFLG to clear this bit.
- 95h.0 **TF3:** Timer3 interrupt flag.  
Set by H/W when Timer3 reaches TM3PSC setting cycles. It is cleared automatically when the program performs the interrupt service routine. S/W can write FEh to INTFLG to clear this bit.

*Note: S/W can write 0 to clear a flag in the INTFLG, but writing 1 has no effect.*

SFR 96h	Bit 7	Bit 6	Bit 5	Bit 4	Bit 3	Bit 2	Bit 1	Bit 0
<b>P1WKUP</b>	P1WKUP							
R/W	R/W							
Reset	0	0	0	0	0	0	0	0

96h.7~0 **P1WKUP:** P1.7~P1.0 pin individual Wake-up / Interrupt enable control  
 0: Disable  
 1: Enable

SFR C5h	Bit 7	Bit 6	Bit 5	Bit 4	Bit 3	Bit 2	Bit 1	Bit 0
<b>P0WKUP</b>	P0WKUP							
R/W	R/W							
Reset	0	0	0	0	0	0	0	0

C5h.7~0 **P0WKUP:** P0.7~P0.0 pin individual Wake-up / Interrupt enable control  
 0: Disable  
 1: Enable

SFR C6h	Bit 7	Bit 6	Bit 5	Bit 4	Bit 3	Bit 2	Bit 1	Bit 0
<b>P2WKUP</b>	P2WKUP							
R/W	R/W							
Reset	0	0	0	0	0	0	0	0

C6h.7~0 **P2WKUP:** P2.7~P2.0 pin individual Wake-up / Interrupt enable control  
 0: Disable  
 1: Enable

SFR C7h	Bit 7	Bit 6	Bit 5	Bit 4	Bit 3	Bit 2	Bit 1	Bit 0
<b>P3WKUP</b>	P3WKUP							
R/W	R/W							
Reset	0	0	0	0	0	0	0	0

C7h.7~0 **P3WKUP:** P3.7~P3.0 pin individual Wake-up / Interrupt enable control  
 0: Disable  
 1: Enable

FR 84h	Bit 7	Bit 6	Bit 5	Bit 4	Bit 3	Bit 2	Bit 1	Bit 0
<b>INTE2</b>	–	PWM1IE	PWM0IE	–	–	–	TKBIE	TKAIE
R/W	–	R/W	R/W	–	–	–	R/W	R/W
Reset	–	0	0	–	–	–	0	0

84h.6 **PWM1IE:** PWM1~PWM6 interrupt enable

0: Disable PWM1~PWM6 interrupt

1: Enable PWM1~PWM6 interrupt

84h.5 **PWM0IE:** PWM0 interrupt enable

0: Disable PWM0 interrupt

1: Enable PWM0 interrupt

84h.1 **TKBIE:** Touch Key B interrupt enable

0: Disable Touch Key B interrupt

1: Enable Touch Key B interrupt

84h.0 **TKAIE:** Touch Key A interrupt enable

0: Disable Touch Key A interrupt

1: Enable Touch Key A interrupt

SFR 85h	Bit 7	Bit 6	Bit 5	Bit 4	Bit 3	Bit 2	Bit 1	Bit 0
<b>INTFLG2</b>	–	PWM1IF	PWM0IF	–	–	–	TKBIF	TKAIF
R/W	–	R/W	R/W	–	–	–	R/W	R/W
Reset	–	0	0	–	–	–	0	0

85h.6 **PWM1IF:** PWM1~PWM6 interrupt flag

Set by H/W at the end of PWM1 period, S/W writes BFh to INTFLG2 to clear this flag.

85h.5 **PWM0IF:** PWM0 interrupt flag

Set by H/W at the end of PWM0 period, S/W writes DFh to INTFLG2 to clear this flag.

85h.1 **TKBIF:** Touch Key B interrupt flag

Set by H/W at the end of Touch Key B scan, S/W writes FDh to INTFLG2 to clear this flag.

85h.0 **TKAIF:** Touch Key A interrupt flag

Set by H/W at the end of Touch Key A scan, S/W writes FEh to INTFLG2 to clear this flag.



## 6. I/O Ports

The Chip has total 26 multi-function I/O pins. There are four Pin modes in this chip, and the functions are shown in the table below. In this table, Port Mode is defined by P0MODL, P0MODH, P1MODL, P1MODH, P2MODL, P3MODL, and P3MODH. Port Data is defined by P0, P1, P2, and P3.

### Port0 & Port1 & P2.1~P2.0 & Port 3

Port Mode	Port Data	Description	Output enable	Internal Pull-up Resistor	Digital Input
Mode0	0	Output Low	Y	N	N
	1	Input with internal Pull-up resistor	N	Y	Y
Mode1	0	Output Low	Y	N	N
	1	Input	N	N	Y
Mode2	0	Output Low	Y	N	N
	1	Output High	Y	N	N
Mode3	X	Analog signal (digital input buffer is disabled)	N	N	N

\*P3.0~P3.2 is Pseudo Open Drain when user select Mode0 or Mode1.

#### I/O Pin Function Table

When user select Mode0 or Mode1, the function is Open drain output low, when Port data=0, the function is output low, when port data=1, the port type is Hi-Z, so user can use digital input in this setting. User can choose mode0 or mode1 for in-out type such as I2C SDA pin. The difference of Mode0 and Mode1 is whether have pull-up resistor or not, when port data = 1, Mode0 have an internal pull-up resistor but mode1 haven't, user can add external pull-up resistors by yourself when using Mode1 if you need.

When user select Mode2, the function is CMOS output, user can choose output low or high by port data value. When user select Mode3, the function is for analog signal, such as ADC pin, the port type is Hi-Z and the digital input Schmitt-trigger is disabled in this mode.

All I/O pins follow the standard 8051 "Read-Modify-Write" feature. If the final output value is related to the value before the command is processed, then this command is the so-called Read-Modify-Write command, such as ANL, INC, CPL. These Read-Modify-Write commands will read Port Data register value instead of the port state value.

Alternative Function	Port Mode	Port Data	Description	Necessary SFR setting
T0, T1, T2, T2EX, INT0, INT1, INT2	0	1	Input with Pull-up	-
	1	1	Input	
RSTn	x	x	Input with Pull-up	XRSTE
TXD	0	X	Pseudo Open Drain Output with Pull-up <sup>[1]</sup>	TXRXSEL
	1	X	Pseudo Open Drain Output <sup>[2]</sup>	
	2	X	CMOS output	
RXD	0	1	Input with Pull-up	TXRXSEL
	1	1	Input	
SCL (Master I <sup>2</sup> C)	2	X	CMOS output	MSCLSEL
SDA (Master I <sup>2</sup> C)	0	X	Open Drain Output with Pull-up	MSDASEL
	1	X	Open Drain Output	
Master Mode, MISO Slave Mode, SCK, MOSI	0	1	Input with Pull-up	SPEN MSTR
	1	1	Input	
Master Mode, SCK, MOSI Slave Mode, MISO	2	X	CMOS Output	
T0O, T1O, T2O	2	X	CMOS Output	T0OE T1OE T2OE
TK0~7	2	0	CMOS output low when TK idling, HW auto switch to Mode3 for analog input during TK scanning	TKCHS
VBGO	X	X	Analog output	VBGOUT
LCDC0~ LCDC3	X	X	Analog output	PILOE
AD0~11,AD15~21	3	X	Analog input	-
CIN1~4 CIP1~4 OPP1~3	3	X	Analog input	-
LDOC	X	X	Analog output	LDOCOUT
OPOUT	X	X	Analog output	OPOUT
DACO	X	X	Analog output	DACOUT
CMPO	2	X	CMOS Output	CMPOE
PWM0~PWM6	2	X	CMOS Output	PWMOE0 PWMOE1 PWMOE2

[1] If TXRXSEL=1, RXD and TXD is Open Drain Output with Pull-up

[2] If TXRXSEL=1, RXD and TXD is Open Drain Output

**Alternative Function Table**

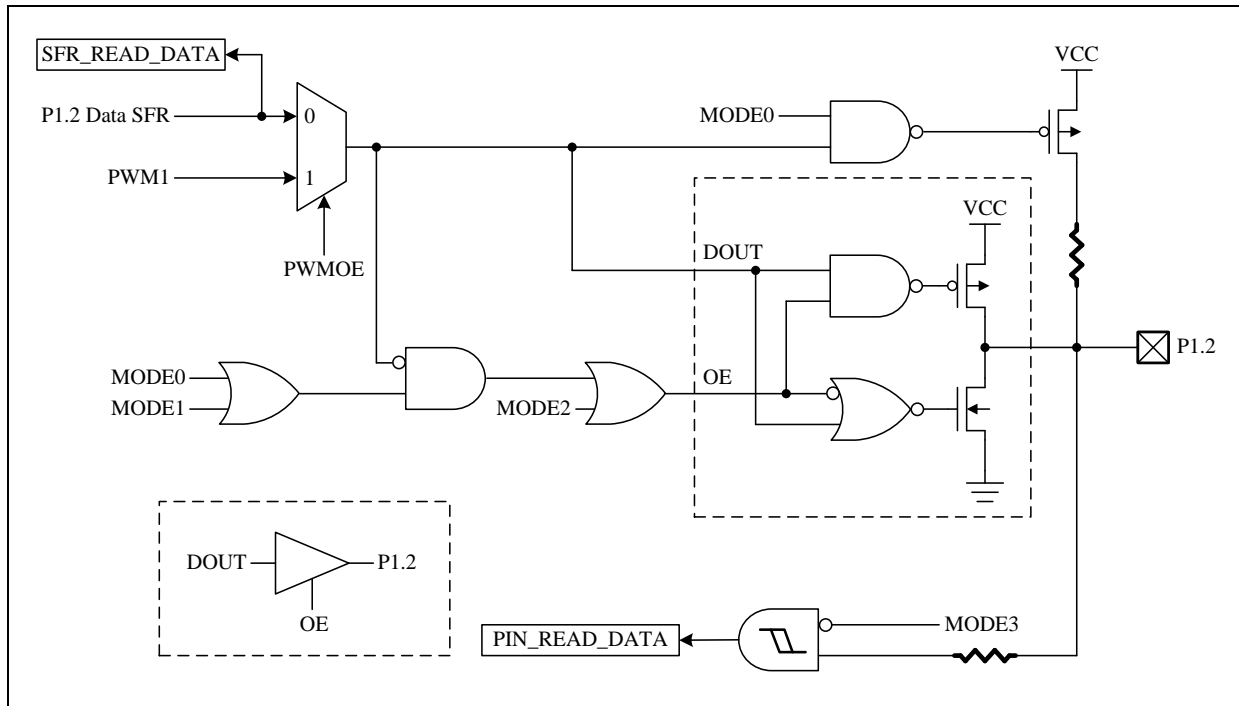
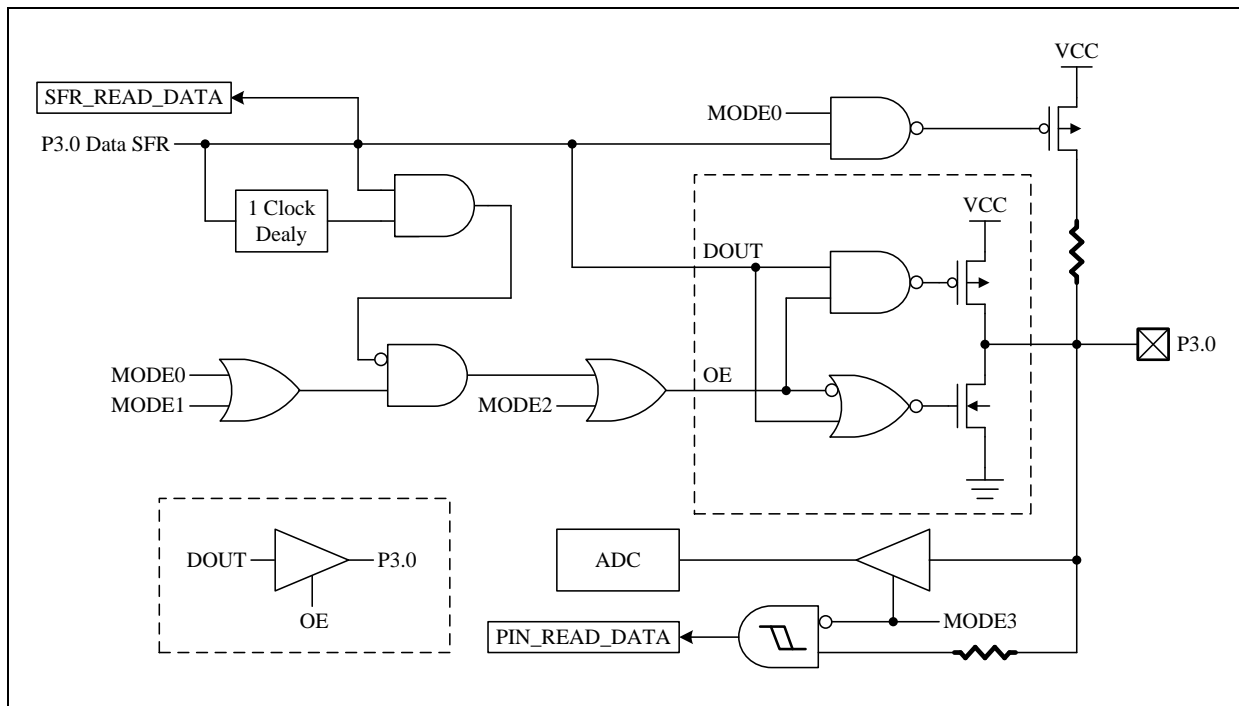
**P1.2 Pin Structure**

**P3.0 Pin Structure**

SFR 80h	Bit 7	Bit 6	Bit 5	Bit 4	Bit 3	Bit 2	Bit 1	Bit 0
<b>P0</b>	P0.7	P0.6	P0.5	P0.4	P0.3	P0.2	P0.1	P0.0
R/W	R/W	R/W	R/W	R/W	R/W	R/W	R/W	R/W
Reset	1	1	1	1	1	1	1	1

80h.7~0 **P0:** Port0 data

SFR 90h	Bit 7	Bit 6	Bit 5	Bit 4	Bit 3	Bit 2	Bit 1	Bit 0
<b>P1</b>	P1.7	P1.6	P1.5	P1.4	P1.3	P1.2	P1.1	P1.0
R/W	R/W	R/W	R/W	R/W	R/W	R/W	R/W	R/W
Reset	1	1	1	1	1	1	1	1

90h.7~0 **P1:** Port1 data

SFR A0h	Bit 7	Bit 6	Bit 5	Bit 4	Bit 3	Bit 2	Bit 1	Bit 0
<b>P2</b>	P2.7	P2.6	P2.5	P2.4	P2.3	P2.2	P2.1	P2.0
R/W	R/W	R/W	R/W	R/W	R/W	R/W	R/W	R/W
Reset	1	1	1	1	1	1	1	1

A0h.1~0 **P2.1~P2.0:** P2.1~P2.0 data

SFR B0h	Bit 7	Bit 6	Bit 5	Bit 4	Bit 3	Bit 2	Bit 1	Bit 0
<b>P3</b>	P3.7	P3.6	P3.5	P3.4	P3.3	P3.2	P3.1	P3.0
R/W	R/W	R/W	R/W	R/W	R/W	R/W	R/W	R/W
Reset	1	1	1	1	1	1	1	1

B0h.7~0 **P3:** Port1 data

SFR F7h	Bit 7	Bit 6	Bit 5	Bit 4	Bit 3	Bit 2	Bit 1	Bit 0
<b>AUX2</b>	WDTE		PWRSAV	VBGOUT	DIV32	IAPTE		MULDIV16
R/W	R/W	R/W	R/W	R/W	R/W	R/W		R/W
Reset	0	0	0	0	0	1	1	0

F7h.4 **VBGOUT:** Bandgap voltage output control

0: Disable

1: Bandgap voltage output to P3.2 pin

SFR AFh	Bit 7	Bit 6	Bit 5	Bit 4	Bit 3	Bit 2	Bit 1	Bit 0
<b>PILOE</b>	–	–	–	–	PILOE3	PILOE2	PILOE1	PILOE0
R/W	–	–	–	–	R/W	R/W	R/W	R/W
Reset	–	–	–	–	0	0	0	0

AFh.3 **PILOE3:** LCD 1/2 bais Output

0: Disable

1: P15 as LCD 1/2 bais Output

AFh.2 **PILOE2:** LCD 1/2 bais Output

0: Disable

1: P14 as LCD 1/2 bais Output

AFh.1 **PILOE1:** LCD 1/2 bais Output

0: Disable

1: P13 as LCD 1/2 bais Output

AFh.0 **PILOE0:** LCD 1/2 bais Output

0: Disable

1: P12 as LCD 1/2 bais Output

SFR 93h	Bit 7	Bit 6	Bit 5	Bit 4	Bit 3	Bit 2	Bit 1	Bit 0
<b>PINMOD</b>	TXRXSEL	T2OE	T1OE	T0OE	P2MOD1		P2MOD0	
R/W	R/W	R/W	R/W	R/W	R/W		R/W	
Reset	0	0	0	0	0	1	0	1

- 93h.7 **TXRXSEL:** UART TXD/RXD pin select  
 0: P31 as TXD, P30 as RXD  
 1: P16 as TXD, P02 as RXD
- 93h.6 **T2OE:** Timer2 signal output (T2O) control  
 0: Disable "Timer2 overflow divided by 2" output to P1.0 pin  
 1: Enable "Timer2 overflow divided by 2" output to P1.0 pin
- 93h.5 **T1OE:** Timer1 signal output (T1O) control  
 0: Disable "Timer1 overflow divided by 2" output to P3.5 pin  
 1: Enable "Timer1 overflow divided by 2" output to P3.5 pin
- 93h.4 **T0OE:** Timer0 signal output (T0O) control  
 0: Disable "Timer0 overflow divided by 64" output to P3.4 pin  
 1: Enable "Timer0 overflow divided by 64" output to P3.4 pin
- 93h.3~2 **P2MOD1:** P2.1 pin control  
 00: Mode0  
 01: Mode1  
 10: Mode2  
 11: Mode3
- 93h.1~0 **P2MOD0:** P2.0 pin control  
 00: Mode0  
 01: Mode1  
 10: Mode2  
 11: Mode3

SFR 91h	Bit 7	Bit 6	Bit 5	Bit 4	Bit 3	Bit 2	Bit 1	Bit 0
<b>P0MODL</b>	P0MOD3		P0MOD2		P0MOD1		P0MOD0	
R/W	R/W		R/W		R/W		R/W	
Reset	0	1	0	1	0	1	0	1

A2h.7~6 **P1MOD3**: P0.3 pin control

00: Mode0  
01: Mode1  
10: Mode2  
11: Mode3

A2h.5~4 **P1MOD2**: P0.2 pin control

00: Mode0  
01: Mode1  
10: Mode2  
11: Mode3

A2h.3~2 **P1MOD1**: P0.1 pin control

00: Mode0  
01: Mode1  
10: Mode2  
11: Mode3

A2h.1~0 **P1MOD0**: P0.0 pin control

00: Mode0  
01: Mode1  
10: Mode2  
11: Mode3

SFR 92h	Bit 7	Bit 6	Bit 5	Bit 4	Bit 3	Bit 2	Bit 1	Bit 0
<b>P0MODH</b>	P0MOD7		P0MOD6		P0MOD5		P0MOD4	
R/W	R/W		R/W		R/W		R/W	
Reset	0	1	0	1	0	1	0	1

A3h.7~6 **P0MOD7**: P0.7 pin control

00: Mode0  
01: Mode1  
10: Mode2  
11: Mode3

A3h.5~4 **P0MOD6**: P0.6 pin control

00: Mode0  
01: Mode1  
10: Mode2  
11: Mode3

A3h.3~2 **P0MOD5**: P0.5 pin control.

00: Mode0  
01: Mode1  
10: Mode2  
11: Mode3

A3h.1~0 **P0MOD4**: P0.4 pin control.

00: Mode0  
01: Mode1  
10: Mode2  
11: Mode3

SFR A2h	Bit 7	Bit 6	Bit 5	Bit 4	Bit 3	Bit 2	Bit 1	Bit 0
<b>P1MODL</b>	P1MOD3		P1MOD2		P1MOD1		P1MOD0	
R/W	R/W		R/W		R/W		R/W	
Reset	0	1	0	1	0	1	0	1

A2h.7~6 **P1MOD3:** P1.3 pin control

- 00: Mode0
- 01: Mode1
- 10: Mode2
- 11: Mode3

A2h.5~4 **P1MOD2:** P1.2 pin control

- 00: Mode0
- 01: Mode1
- 10: Mode2
- 11: Mode3

A2h.3~2 **P1MOD1:** P1.1 pin control

- 00: Mode0
- 01: Mode1
- 10: Mode2
- 11: Mode3

A2h.1~0 **P1MOD0:** P1.0 pin control

- 00: Mode0
- 01: Mode1
- 10: Mode2
- 11: Mode3

SFR A3h	Bit 7	Bit 6	Bit 5	Bit 4	Bit 3	Bit 2	Bit 1	Bit 0
<b>P1MODH</b>	P1MOD7		P1MOD6		P1MOD5		P1MOD4	
R/W	R/W		R/W		R/W		R/W	
Reset	0	1	0	1	0	1	0	1

A3h.7~6 **P1MOD7:** P1.7 pin control

- 00: Mode0
- 01: Mode1
- 10: Mode2
- 11: Mode3

A3h.5~4 **P1MOD6:** P1.6 pin control

- 00: Mode0
- 01: Mode1
- 10: Mode2
- 11: Mode3

A3h.3~2 **P1MOD5:** P1.5 pin control.

- 00: Mode0
- 01: Mode1
- 10: Mode2
- 11: Mode3

A3h.1~0 **P1MOD4:** P1.4 pin control.

- 00: Mode0
- 01: Mode1
- 10: Mode2
- 11: Mode3

SFR A4h	Bit 7	Bit 6	Bit 5	Bit 4	Bit 3	Bit 2	Bit 1	Bit 0
<b>P3MODL</b>	P3MOD3		P3MOD2		P3MOD1		P3MOD0	
R/W	R/W		R/W		R/W		R/W	
Reset	0	1	0	1	0	1	0	1

A4h.7~6 **P3MOD3:** P3.3 pin control

- 00: Mode0
- 01: Mode1
- 10: Mode2
- 11: Mode3

A4h.5~4 **P3MOD2:** P3.2 pin control

- 00: Mode0
- 01: Mode1
- 10: Mode2
- 11: Mode3

A4h.3~2 **P3MOD1:** P3.1 pin control.

- 00: Mode0
- 01: Mode1
- 10: Mode2
- 11: Mode3

A4h.1~0 **P3MOD0:** P3.0 pin control.

- 00: Mode0
- 01: Mode1
- 10: Mode2
- 11: Mode3

SFR A5h	Bit 7	Bit 6	Bit 5	Bit 4	Bit 3	Bit 2	Bit 1	Bit 0
<b>P3MODH</b>	P3MOD7		P3MOD6		P3MOD5		P3MOD4	
R/W	R/W		R/W		R/W		R/W	
Reset	0	1	0	1	0	1	0	1

A5h.7~6 **P3MOD7:** P3.7 pin control

- 00: Mode0
- 01: Mode1
- 10: Mode2
- 11: Mode3

A5h.5~4 **P3MOD6:** P3.6 pin control

- 00: Mode0
- 01: Mode1
- 10: Mode2
- 11: Mode3

A5h.3~2 **P3MOD5:** P3.5 pin control

- 00: Mode0
- 01: Mode1
- 10: Mode2
- 11: Mode3

A5h.1~0 **P3MOD4:** P3.4 pin control

- 00: Mode0
- 01: Mode1
- 10: Mode2
- 11: Mode3



SFR A6h	Bit 7	Bit 6	Bit 5	Bit 4	Bit 3	Bit 2	Bit 1	Bit 0
<b>PWM0E0</b>	PWM1OE3	PWM1OE2	PWM1OE1	PWM1OE0	PWM0NOE1	PWM0POE1	PWM0NOE0	PWM0POE0
R/W	R/W	R/W	R/W	R/W	R/W	R/W	R/W	R/W
Reset	0	0	0	0	0	0	0	0

- A6h.7 **PWM1OE3**: PWM1 output control  
0: Disable 1: PWM1 enable and output to P1.2
- A6h.6 **PWM1OE2**: PWM1 output control  
0: Disable 1: PWM1 enable and output to P0.6
- A6h.5 **PWM1OE1**: PWM1 output control  
0: Disable 1: PWM1 enable and output to P0.4
- A6h.4 **PWM1OE0**: PWM1 output control  
0: Disable 1: PWM1 enable and output to P0.2
- A6h.3 **PWM0NOE1**: PWM0N output control  
0: Disable 1: PWM0N enable and output to P3.6
- A6h.2 **PWM0POE1**: PWM0P output control  
0: Disable 1: PWM0P enable and output to P3.5
- A6h.1 **PWM0NOE0**: PWM0N output control  
0: Disable 1: PWM0N enable and output to P0.4
- A6h.0 **PWM0POE0**: PWM0P output control  
0: Disable 1: PWM0P enable and output to P0.3

SFR B6h	Bit 7	Bit 6	Bit 5	Bit 4	Bit 3	Bit 2	Bit 1	Bit 0
<b>PWM0E1</b>	PWM4OE3	PWM4OE2	PWM4OE1	PWM4OE0	PWM3OE1	PWM3OE0	PWM2OE1	PWM2OE0
R/W	R/W	R/W	R/W	R/W	R/W	R/W	R/W	R/W
Reset	0	0	0	0	0	0	0	0

- B6h.7 **PWM4OE3**: PWM4 output control  
0: Disable 1: PWM4 enable and output to P3.6
- B6h.6 **PWM4OE2**: PWM4 output control  
0: Disable 1: PWM4 enable and output to P1.5
- B6h.5 **PWM4OE1**: PWM4 output control  
0: Disable 1: PWM4 enable and output to P0.4
- B6h.4 **PWM4OE0**: PWM4 output control  
0: Disable 1: PWM4 enable and output to P0.0
- B6h.3 **PWM3OE1**: PWM3 output control  
0: Disable 1: PWM3 enable and output to P3.4
- B6h.2 **PWM3OE0**: PWM3 output control  
0: Disable 1: PWM3 enable and output to P1.0
- B6h.1 **PWM2OE1**: PWM2 output control  
0: Disable 1: PWM2 enable and output to P3.6
- B6h.0 **PWM2OE0**: PWM2 output control  
0: Disable 1: PWM2 enable and output to P1.1

SFR B7h	Bit 7	Bit 6	Bit 5	Bit 4	Bit 3	Bit 2	Bit 1	Bit 0
<b>PWM0E2</b>	MSDASEL	MSCLSEL	PWM6OE2	PWM6OE1	PWM6OE0	PWM5OE2	PWM5OE1	PWM5OE0
R/W	R/W	R/W	R/W	R/W	R/W	R/W	R/W	R/W
Reset	0	0	0	0	0	0	0	0

- B7h.7 **MSDASEL**: Master I<sup>2</sup>C SDA select  
0: P3.5 as Master I<sup>2</sup>C SDA  
1: P1.6 as Master I<sup>2</sup>C SDA
- B7h.6 **MSCLSEL**: Master I<sup>2</sup>C SCL select



- 0: P1.3 as Master I<sup>2</sup>C SCL  
1: P0.2 as Master I<sup>2</sup>C SCL
- B7h.5 **PWM6OE2:** PWM6 output control  
0: Disable      1: PWM6 enable and output to P1.3
- B7h.4 **PWM6OE1:** PWM6 output control  
0: Disable      1: PWM6 enable and output to P0.7
- B7h.3 **PWM6OE0:** PWM6 output control  
0: Disable      1: PWM6 enable and output to P0.3
- B7h.2 **PWM5OE2:** PWM5 output control  
0: Disable      1: PWM5 enable and output to P1.4
- B7h.1 **PWM5OE1:** PWM5 output control  
0: Disable      1: PWM5 enable and output to P0.6
- B7h.0 **PWM5OE0:** PWM5 output control  
0: Disable      1: PWM5 enable and output to P0.1

## 7. Timers

Timer0, Timer1 and Timer2 are provided as standard 8051 compatible timer/counter. Compare to the traditional 12T 8051, the Chip's Timer0/1/2 use 2 System clock cycle as the time base unit. That is, in timer mode, these timers increase at every “2 System clock” rate; in counter mode, T0/T1/T2 pin input pulse must be wider than 2 System clock to be seen by this device.

This device can generate various frequency waveform pin output for Buzzer. The T0O, T1O, and T2O waveform is divided by Timer0/Timer1/Timer2 overflow signal. The T0O waveform is Timer0 overflow divided by 64, T1O waveform is Timer1 overflow divided by 2, and T2O waveform is Timer2 overflow divided by 2. User can control their frequency by Timers auto reload speed. Set T0OE (93h.6), T1OE (93h.5), and T2OE (93h.4) can output these waveforms.

### 7.1 Timer0 / Timer1

TCON and TMOD are used to set the mode of operation and to control the running and interrupt generation of the Timer0/1, with the timer/counter values stored in two pairs of 8-bit registers (TL0, TH0, and TL1, TH1).

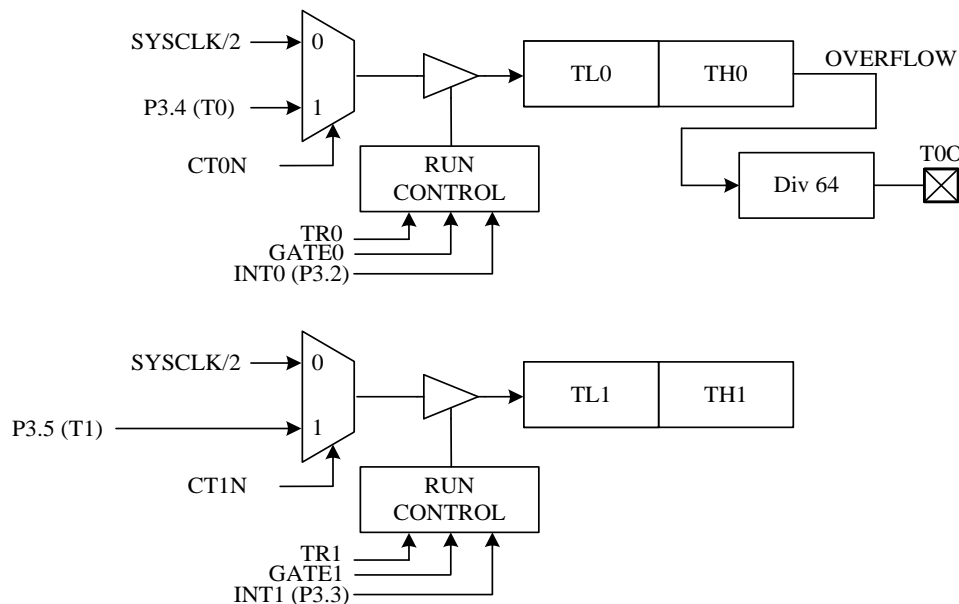

Timer0 and Timer1 Structure

SFR 88h	Bit 7	Bit 6	Bit 5	Bit 4	Bit 3	Bit 2	Bit 1	Bit 0
<b>TCON</b>	TF1	TR1	TF0	TR0	IE1	IT1	IE0	IT0
R/W	R/W	R/W	R/W	R/W	R/W	R/W	R/W	R/W
Reset	0	0	0	0	0	0	0	0

- 88h.7 **TF1:** Timer1 overflow flag  
Set by H/W when Timer/Counter 1 overflows  
Cleared by H/W when CPU vectors into the interrupt service routine.
- 88h.6 **TR1:** Timer1 run control  
0: Timer1 stops  
1: Timer1 runs
- 88h.5 **TF0:** Timer0 overflow flag  
Set by H/W when Timer/Counter 0 overflows  
Cleared by H/W when CPU vectors into the interrupt service routine.

88h.4 **TR0:** Timer0 run control  
 0: Timer0 stops  
 1: Timer0 runs

SFR 89h	Bit 7	Bit 6	Bit 5	Bit 4	Bit 3	Bit 2	Bit 1	Bit 0
<b>TMOD</b>	GATE1	CT1N	TMOD1		GATE0	CT0N	TMOD0	
R/W	R/W	R/W	R/W		R/W	R/W	R/W	
Reset	0	0	0	0	0	0	0	0

89h.7 **GATE1:** Timer1 gating control bit  
 0: Timer1 enable when TR1 bit is set  
 1: Timer1 enable only while the INT1 pin is high and TR1 bit is set

89h.6 **CT1N:** Timer1 Counter/Timer select bit  
 0: Timer mode, Timer1 data increases at 2 System clock cycle rate  
 1: Counter mode, Timer1 data increases at T1 pin's negative edge

89h.5~4 **TMOD1:** Timer1 mode select  
 00: 8-bit timer/counter (TH1) and 5-bit prescaler (TL1)  
 01: 16-bit timer/counter  
 10: 8-bit auto-reload timer/counter (TL1). Reloaded from TH1 at overflow.  
 11: Timer1 stops

89h.3 **GATE0:** Timer0 gating control bit  
 0: Timer0 enable when TR0 bit is set  
 1: Timer0 enable only while the INT0 pin is high and TR0 bit is set

89h.2 **CT0N:** Timer0 Counter/Timer select bit  
 0: Timer mode, Timer0 data increases at 2 System clock cycle rate  
 1: Counter mode, Timer0 data increases at T0 pin's negative edge

89h.1~0 **TMOD0:** Timer0 mode select  
 00: 8-bit timer/counter (TH0) and 5-bit prescaler (TL0)  
 01: 16-bit timer/counter  
 10: 8-bit auto-reload timer/counter (TL0). Reloaded from TH0 at overflow.  
 11: TL0 is an 8-bit timer/counter. TH0 is an 8-bit timer/counter using Timer1's TR1 and TF1 bits.

SFR 8Ah	Bit 7	Bit 6	Bit 5	Bit 4	Bit 3	Bit 2	Bit 1	Bit 0
<b>TL0</b>	TL0							
R/W	R/W							
Reset	0	0	0	0	0	0	0	0

8Ah.7~0 **TL0:** Timer0 data low byte

SFR 8Bh	Bit 7	Bit 6	Bit 5	Bit 4	Bit 3	Bit 2	Bit 1	Bit 0
<b>TL1</b>	TL1							
R/W	R/W							
Reset	0	0	0	0	0	0	0	0

8Bh.7~0 **TL1:** Timer1 data low byte

SFR 8Ch	Bit 7	Bit 6	Bit 5	Bit 4	Bit 3	Bit 2	Bit 1	Bit 0
<b>TH0</b>	TH0							
R/W	R/W							
Reset	0	0	0	0	0	0	0	0

8Ch.7~0 **TH0:** Timer0 data high byte

SFR 8Dh	Bit 7	Bit 6	Bit 5	Bit 4	Bit 3	Bit 2	Bit 1	Bit 0
<b>TH1</b>	TH1							
R/W	R/W							

Reset	0	0	0	0	0	0	0	0
-------	---	---	---	---	---	---	---	---

8Dh.7~0 **TH1:** Timer1 data high byte

SFR 93h	Bit 7	Bit 6	Bit 5	Bit 4	Bit 3	Bit 2	Bit 1	Bit 0
<b>PINMOD</b>	TXRXSEL	T2OE	T1OE	T0OE	P2MOD1		P2MOD0	
R/W	R/W	R/W	R/W	R/W	R/W		R/W	
Reset	0	0	0	0	0	1	0	1

93h.5 **T1OE:** Timer1 signal output (T1O) control  
 0: Disable "Timer1 overflow divided by 2" output to P3.5 pin  
 1: Enable "Timer1 overflow divided by 2" output to P3.5 pin

93h.4 **T0OE:** Timer0 signal output (T0O) control  
 0: Disable "Timer0 overflow divided by 64" output to P3.4 pin  
 1: Enable "Timer0 overflow divided by 64" output to P3.4 pin

*Note:* See also Chapter 5 for more information on Timer0/1 interrupt enable and priority.

*Note:* See also Chapter 6 for details on T0O pin output settings.

## 7.2 Timer2

Timer2 is controlled through the TCON2 register with the low and high bytes of Timer/Counter2 stored in TL2 and TH2 and the low and high bytes of the Timer2 reload/capture registers stored in RCAP2L and RCAP2H.

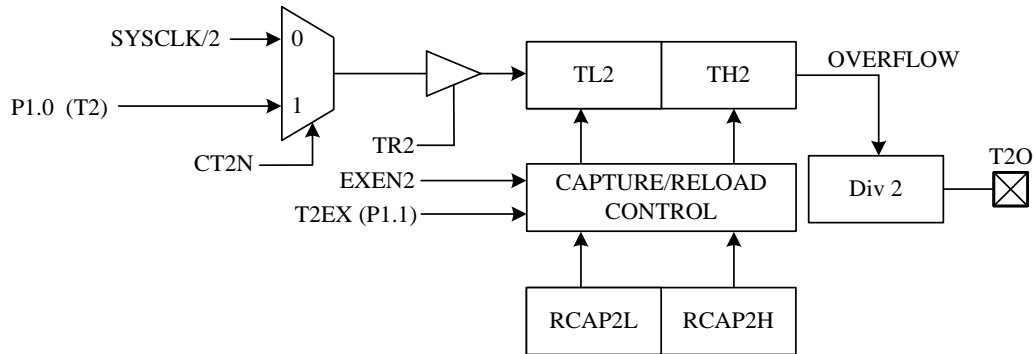

**Timer2 Structure**

SFR C8h	Bit 7	Bit 6	Bit 5	Bit 4	Bit 3	Bit 2	Bit 1	Bit 0
<b>T2CON</b>	TF2	EXF2	RCLK	TCLK	EXEN2	TR2	CT2N	CPRL2N
R/W	R/W	R/W	R/W	R/W	R/W	R/W	R/W	R/W
Reset	0	0	0	0	0	0	0	0

- C8h.7 **TF2:** Timer2 overflow flag  
Set by H/W when Timer/Counter 2 overflows unless RCLK=1 or TCLK=1. This bit must be cleared by S/W.
- C8h.6 **EXF2:** T2EX interrupt pin falling edge flag  
Set when a capture or a reload is caused by a negative transition on T2EX pin if EXEN2=1. This bit must be cleared by S/W.
- C8h.5 **RCLK:** UART receive clock control bit  
0: Use Timer1 overflow as receive clock for serial port in mode 1 or 3  
1: Use Timer2 overflow as receive clock for serial port in mode 1 or 3
- C8h.4 **TCLK:** UART transmit clock control bit  
0: Use Timer1 overflow as transmit clock for serial port in mode 1 or 3  
1: Use Timer2 overflow as transmit clock for serial port in mode 1 or 3
- C8h.3 **EXEN2:** T2EX pin enable  
0: T2EX pin disable  
1: T2EX pin enable, it cause a capture or reload when a negative transition on T2EX pin is detected if RCLK=TCLK=0
- C8h.2 **TR2:** Timer2 run control  
0: Timer2 stops  
1: Timer2 runs
- C8h.1 **CT2N:** Timer2 Counter/Timer select bit  
0: Timer mode, Timer2 data increases at 2 System clock cycle rate  
1: Counter mode, Timer2 data increases at T2 pin's negative edge
- C8h.0 **CPRL2N:** Timer2 Capture/Reload control bit  
0: Reload mode, auto-reload on Timer2 overflows or negative transitions on T2EX pin if EXEN2=1.  
1: Capture mode, capture on negative transitions on T2EX pin if EXEN2=1.  
If RCLK=1 or TCLK=1, CPRL2N is ignored and timer is forced to auto-reload on Timer2 overflow.

SFR CAh	Bit 7	Bit 6	Bit 5	Bit 4	Bit 3	Bit 2	Bit 1	Bit 0
<b>RCP2L</b>	RCP2L							
R/W	R/W							
Reset	0	0	0	0	0	0	0	0

CAh.7~0 **RCP2L**: Timer2 reload/capture data low byte

SFR CBh	Bit 7	Bit 6	Bit 5	Bit 4	Bit 3	Bit 2	Bit 1	Bit 0
<b>RCP2H</b>	RCP2H							
R/W	R/W							
Reset	0	0	0	0	0	0	0	0

CBh.7~0 **RCP2H**: Timer2 reload/capture data high byte

SFR CCh	Bit 7	Bit 6	Bit 5	Bit 4	Bit 3	Bit 2	Bit 1	Bit 0
<b>TL2</b>	TL2							
R/W	R/W							
Reset	0	0	0	0	0	0	0	0

CCh.7~0 **TL2**: Timer2 data low byte

SFR CDh	Bit 7	Bit 6	Bit 5	Bit 4	Bit 3	Bit 2	Bit 1	Bit 0
<b>TH2</b>	TH2							
R/W	R/W							
Reset	0	0	0	0	0	0	0	0

CDh.7~0 **TH2**: Timer2 data high byte

SFR 93h	Bit 7	Bit 6	Bit 5	Bit 4	Bit 3	Bit 2	Bit 1	Bit 0
<b>PINMOD</b>	TXXRXSEL	T2OE	T1OE	T0OE	P2MOD1		P2MOD0	
R/W	R/W	R/W	R/W	R/W	R/W		R/W	
Reset	0	0	0	0	0	1	0	1

93h.6 **T2OE**: Timer2 signal output (T2O) control

0: Disable "Timer2 overflow divided by 2" output to P1.0 pin

1: Enable "Timer2 overflow divided by 2" output to P1.0 pin

*Note*: See also Chapter 5 for more information on Timer2 interrupt enable and priority.

*Note*: See also Chapter 6 for details on T2O pin output settings.

### 7.3 Timer3

Timer3 works as a time-base counter, which generates interrupts periodically. Timer3 has 8 kinds of Interrupt period to choose, user can select Timer3 clock source by TM3CKS (94h.6), and this clock source can be divided by TM3PSC (94h.1~0).

unit: ms		TM3CKS	
		0	1
TM3PSC	00	886	664
	01	111	83
	10	55	42
	11	14	10

**TM3 interrupt period @3V**

unit: ms		TM3CKS	
		0	1
TM3PSC	00	799	599
	01	100	75
	10	50	37
	11	12	9

**TM3 interrupt period @5V**

SFR 94h	Bit 7	Bit 6	Bit 5	Bit 4	Bit 3	Bit 2	Bit 1	Bit 0
<b>OPTION</b>	UART1W	TM3CKS	WDTPSC		ADCKS		TM3PSC	
R/W	R/W	R/W	R/W		R/W		R/W	
Reset	0	0	0	0	0	0	0	0

94h.6 **TM3CKS:** Timer3 clock source select.

0: Slow clock (SRC)

1: SRC/0.75

94h.1~0 **TM3PSC:** Timer3 prescaler.

00: Timer3 is 32768 clock cycle

01: Timer3 is 4096 clock cycle

10: Timer3 is 2048 clock cycle

11: Timer3 is 512 clock cycle

SFR 95h	Bit 7	Bit 6	Bit 5	Bit 4	Bit 3	Bit 2	Bit 1	Bit 0
<b>INTFLG</b>	LVDIF	CMPIF	TKIF	ADIF	–	IE2	PXIF	TF3
R/W	R/W	R/W	R/W	R/W	–	R/W	R/W	R/W
Reset	0	0	0	0	–	0	0	0

95h.0 **TF3:** Timer3 Interrupt Flag

Set by H/W when Timer3 reaches TM3PSC setting cycles. Cleared automatically when the program performs the interrupt service routine. S/W can write FEh to INTFLG to clear this bit.

SFR F8h	Bit 7	Bit 6	Bit 5	Bit 4	Bit 3	Bit 2	Bit 1	Bit 0
<b>AUX1</b>	CLRWDT	CLR3TM3	–	ADSOC	CLRPWM0	CLRPWM1	LD0COUT	DPSEL
R/W	R/W	R/W	–	R/W	R/W	R/W	R/W	R/W
Reset	0	0	–	0	1	1	0	0

F8h.6 **CLR3TM3:** Set 1 to clear Timer3.

*Note:* also refer to Chapter 5 for more information about Timer3 Interrupt enable and priority.



## 8. UART

The UART uses SCON and SBUF SFRs. SCON is the control register, SBUF is the data register. Data is written to SBUF for transmission and SBUF is read to obtain received data. The received data and transmitted data registers are completely independent. In addition to standard 8051's full duplex mode, this chip also provides one wire mode. If the UART1W bit is set, both transmit and receive data use P3.1 pin.

In the 8051 standard, the calculation of the UART baud rate depends on Timer1 or Timer2, but the user can also use the UART dedicated Timer to define a new baud rate by UARTCON.

SFR 87h	Bit 7	Bit 6	Bit 5	Bit 4	Bit 3	Bit 2	Bit 1	Bit 0
<b>PCON</b>	SMOD	–	–	–	GF1	GF0	PD	IDL
R/W	R/W	–	–	–	R/W	R/W	R/W	R/W
Reset	0	–	–	–	0	0	0	0

87h.7 **SMOD:** UART double baud rate control bit  
 0: Disable UART double baud rate  
 1: Enable UART double baud rate

SFR 93h	Bit 7	Bit 6	Bit 5	Bit 4	Bit 3	Bit 2	Bit 1	Bit 0
<b>PINMOD</b>	TXRXSEL	T2OE	T1OE	T0OE	P2MOD1		P2MOD0	
R/W	R/W	R/W	R/W	R/W	R/W		R/W	
Reset	0	0	0	0	0	1	0	1

93h.7 **TXRXSEL:** UART TXD/RXD pin select  
 0: P31 as TXD, P30 as RXD  
 1: P16 as TXD, P02 as RXD

SFR 94h	Bit 7	Bit 6	Bit 5	Bit 4	Bit 3	Bit 2	Bit 1	Bit 0
<b>OPTION</b>	UART1W	TM3CKS	WDTOSC		ADCKS		TM3PSC	
R/W	R/W	R/W	R/W		R/W		R/W	
Reset	0	0	0	0	0	0	0	0

94h.7 **UART1W:** One wire UART mode enable, both TXD/RXD use P3.1 or p1.6 pin  
 0: Disable one wire UART mode  
 1: Enable one wire UART mode

SFR 98h	Bit 7	Bit 6	Bit 5	Bit 4	Bit 3	Bit 2	Bit 1	Bit 0
<b>SCON</b>	SM0	SM1	SM2	REN	TB8	RB8	TI	RI
R/W	R/W	R/W	R/W	R/W	R/W	R/W	R/W	R/W
Reset	0	0	0	0	0	0	0	0

- 98h.7~6 **SM0,SM1**: Serial port mode select bit 0,1  
 00: Mode0: 8 bit shift register, Baud Rate= $F_{\text{SYSCLK}}/2$   
 01: Mode1: 8 bit UART, Baud Rate is variable  
 10: Mode2: 9 bit UART, Baud Rate= $F_{\text{SYSCLK}}/32$  or/64  
 11: Mode3: 9 bit UART, Baud Rate is variable
- 98h.5 **SM2**: Serial port mode select bit 2  
 SM2 enables multiprocessor communication over a single serial line and modifies the above as follows. In Modes 2 & 3, if SM2 is set then the received interrupt will not be generated if the received ninth data bit is 0. In Mode 1, the received interrupt will not be generated unless a valid stop bit is received. In Mode 0, SM2 should be 0.
- 98h.4 **REN**: UART reception enable  
 0: Disable reception  
 1: Enable reception
- 98h.3 **TB8**: Transmit Bit 8, the ninth bit to be transmitted in Mode 2 and 3
- 98h.2 **RB8**: Receive Bit 8, contains the ninth bit that was received in Mode 2 and 3 or the stop bit is Mode 1 if SM2=0
- 98h.1 **TI**: Transmit interrupt flag  
 Set by H/W at the end of the eighth bit in Mode 0, or at the beginning of the stop bit in other modes. Must be cleared by S/W.
- 98h.0 **RI**: Receive interrupt flag  
 Set by H/W at the end of the eighth bit in Mode 0, or at the sampling point of the stop bit in other modes. Must be cleared by S/W.

SFR 99h	Bit 7	Bit 6	Bit 5	Bit 4	Bit 3	Bit 2	Bit 1	Bit 0
<b>SBUF</b>	SBUF							
R/W	R/W							
Reset	-	-	-	-	-	-	-	-

- 99h.7~0 **SBUF**: UART transmit and receive data. Transmit data is written to this location and receive data is read from this location, but the paths are independent.

SFR DFh	Bit 7	Bit 6	Bit 5	Bit 4	Bit 3	Bit 2	Bit 1	Bit 0
<b>UARTCON</b>	UARTBRS	UARTBRP						
R/W	R/W	R/W	R/W	R/W	R/W	R/W	R/W	R/W
Reset	0	0	0	0	0	0	0	0

- DFh.7 **UARTBRS**: UART Baud Rate Source Select.  
 0: 8051 default Baud Rate source select  
 1: UART Baud Rate select as UARTBRP
- DFh.6~0 **UARTBRP**: Define UART Baud Rate Prescaler.  
 UART Baud Rate =  $F_{\text{sys}}/32/\text{UARTBRP}$

$F_{\text{SYSCLK}}$  denotes System clock frequency, the UART baud rate is calculated as below.

- **Mode 0:**  
 Baud Rate= $F_{\text{SYSCLK}}/2$
- **Mode 1, 3:** if using Timer1 auto reload mode  
 Baud Rate=  $(\text{SMOD} + 1) \times F_{\text{SYSCLK}} / (32 \times 2 \times (256 - \text{TH1}))$

- **Mode 1, 3:** if using Timer2  
Baud Rate=Timer2 overflow rate/16 =  $F_{\text{SYSCLK}} / (32 \times (65536 - \text{RCP2H}, \text{RCP2L}))$
- **Mode 1, 3:** if using UART dedicated Timer (UARTBRS=1)  
Baud Rate=  $F_{\text{sys}}/32/\text{UARTBRP}$
- **Mode 2:**  
Baud Rate=  $(\text{SMOD} + 1) \times F_{\text{SYSCLK}}/64$

*Note: also refer to Chapter 5 for more information about UART Interrupt enable and priority.*

*Note: also refer to Chapter 7 for more information about how Timer2 controls UART clock.*

## 9. PWMs

This Chip has seven 16-bit PWM modules, PWM0 to PWM6. The PWM can generate varies frequency waveform with 65536 duty resolution on the basis of the PWM clock. The PWM clock can select FRC double frequency (FRC x 2), FRC or  $F_{SYSCLK}$  as its clock source. Users should pay attention to the setting; the period of PWM must be greater than duty.

The pin mode SFR controls the PWM output waveform format. Mode1 makes the PWM open drain output and Mode2 makes the PWM CMOS push-pull output.

The 16-bit PWM0PRD, PWM1PRD and PWM0D ~ PWM6D registers all have a low and high byte structure. The high bytes can be directly accessed, but as the low bytes can only be accessed via an internal 8-bit buffer, reading or writing to these register pairs must be carried out in a specific way. The important point to notes is that data transfer to and from the 8-bit buffer and its related low byte only takes place when write or read operation to its corresponding high bytes is executed. Briefly speaking, write low byte first and then high byte; read high byte first and then low byte.

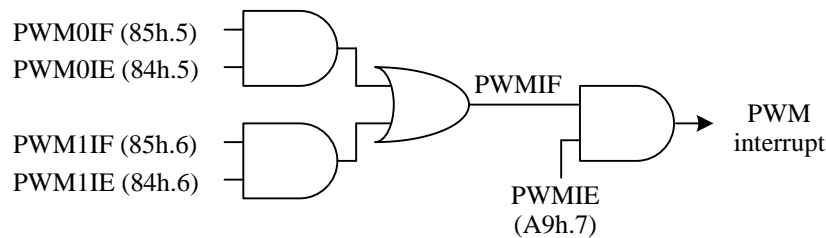

**PWM interrupt structure**

### 9.1 PWM0

The PWM0POE0 / PWM0POE1 are used to select the output for PWM0P, and the PWM0NOE0 / PWM0NOE1 are used to select the output for PWM0N. These four bits also can be PWM0 control bit. If those four bits are cleared, the PWM0 will be cleared and stopped, otherwise the PWM0 is running. The CLRPWM0 bit has the same function. When CLRPWM0 bit is set, the PWM0 will be cleared and held, otherwise the PWM0 is running. The PWM0 structure is shown as follow.

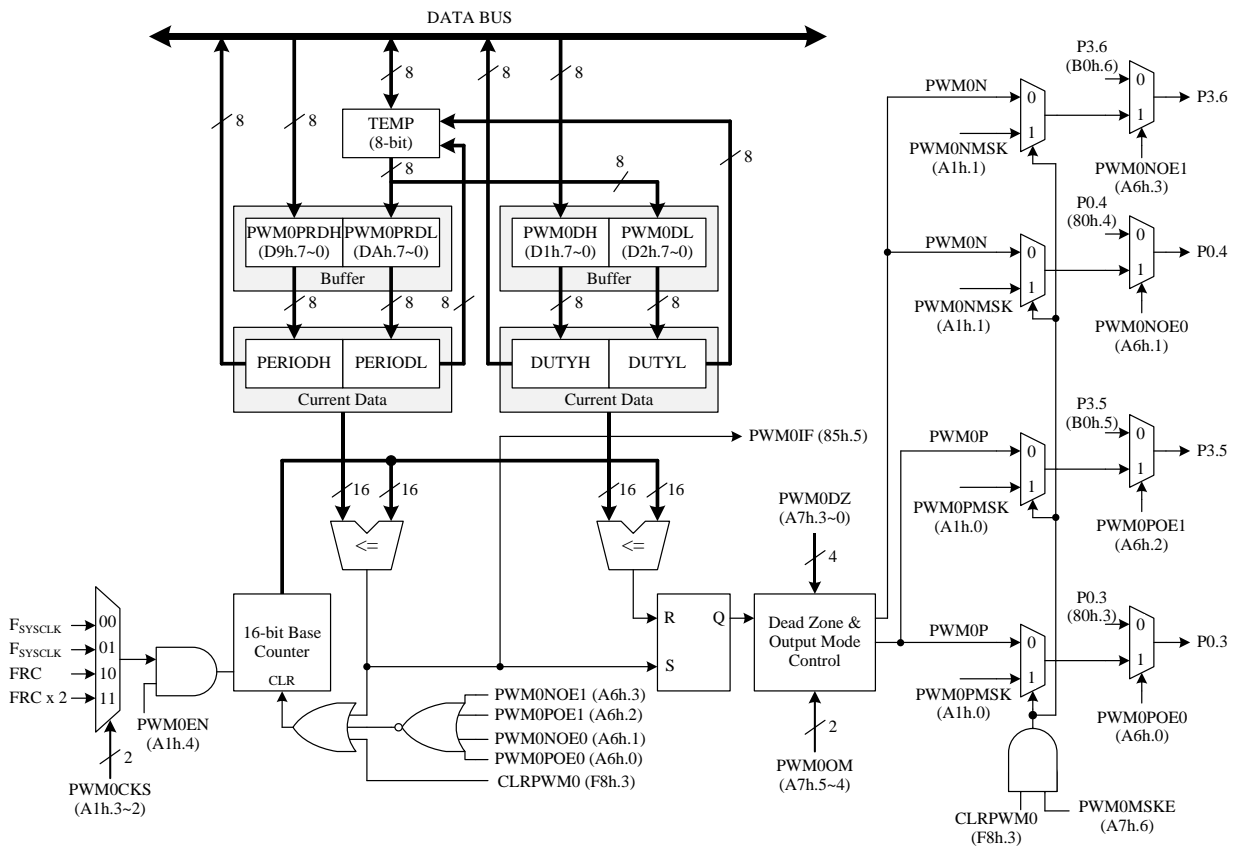

**PWM0 Structure**

The PWM0 duty cycle can be changed by writing to PWMODH and PWMODL. The PWM0 output signal resets to a low level whenever the 16-bit base counter matches the 16-bit PWM0 duty register {PWMODH, PWMODL}. The PWM0 period can be set by writing the period value to the PWMOPRDH and PWMOPRDL registers. After writing the PWMOD or PWMOPRD register, the new values will immediately save to their own buffer. H/W will update these values at the end of current period or while PWM0 is cleared. At the end of current period, H/W will set the PWM0IF bit and generate an interrupt if a PWM0 interrupt is enabled.

The PWM0 has two operation modes, normal mode and half-bridge mode. PWM0 output signal can be output via PWMOP and PWMON with four different modes. These two outputs are non-overlapped with time interval T<sub>nov</sub>. Non-overlapping time interval is also named as dead zone or dead band. T<sub>nov</sub> is determined by setting PWM0DZ bits. The value 0~15 of PWM0DZ map onto 0~15, 16 PWM0CLK cycles respectively. If PWM0DZ=0, PWM0 outputs is directly passed to PWMOP and PWMON so that waveforms of them have the same duty cycle. Note that, if high pulse width or low pulse width of PWM0 output is shorter than T<sub>nov</sub>, the real waveforms of these two outputs will differ from the expected waveforms. If the PWM0MSKE bit is set, the outputs can be masked to force output fix signal while S/W set the CLRPWM0 bit is set by H/W.

**Normal Mode**

The normal mode PWM is a simple structure, which switches its output high and low at uniform repeatable intervals. The PWM0D is the output duty cycle, and the output period is PWMOPRD+1. The output waveform of PWM0 is shown below.

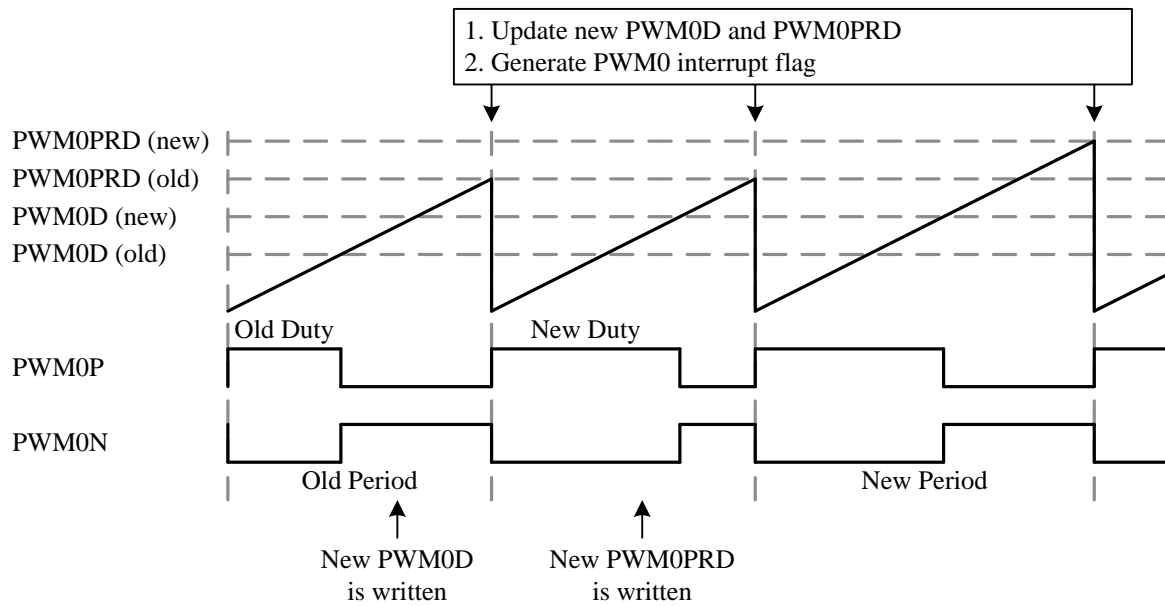

**PWM0 normal mode output waveform (PWM0OM=0, PWM0DZ=0)**

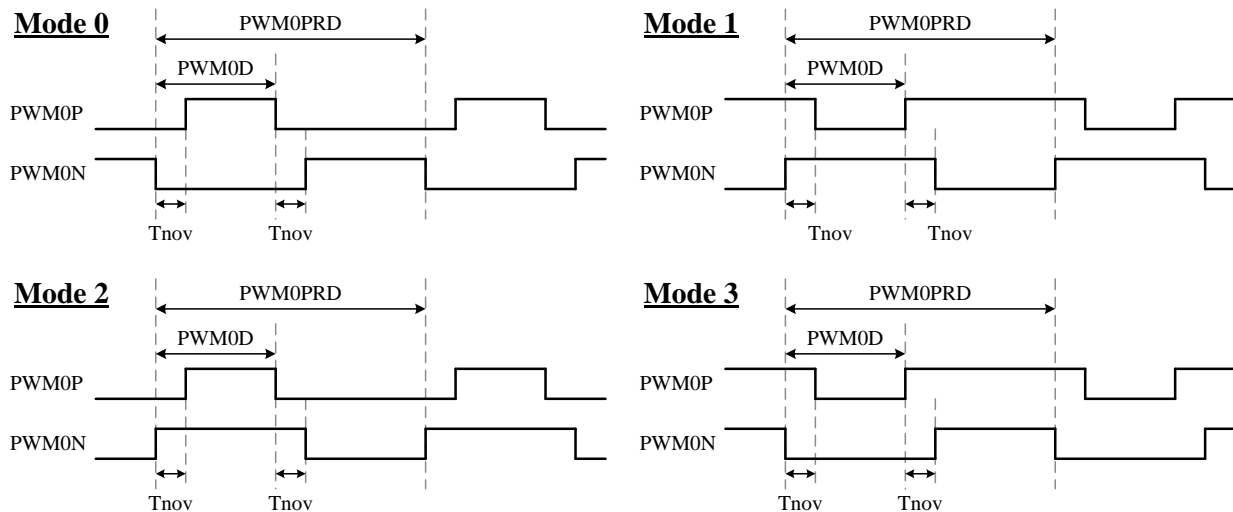

**PWM0 normal mode output modes**

### Half-Bridge Mode

The half-bridge mode PWM is similar to the normal mode but Dead zone is prohibited in half-bridge mode (SFR PWM0DZ must be 0). It has two frames in a period, PWM0P only output in the first frame, PWM0N only output in the second frame. The width of these two frames must be same, so their width is the integer part of  $PWM0PRD/2$ . Because each output channel only output in one frame, the maximum duty cycle is same as the width of a frame. If the PWM0D is larger than  $PWM0PRD/2$ , H/W will force set the duty cycle to  $PWM0PRD/2$ . Following figure shows the output waveform and the output modes.

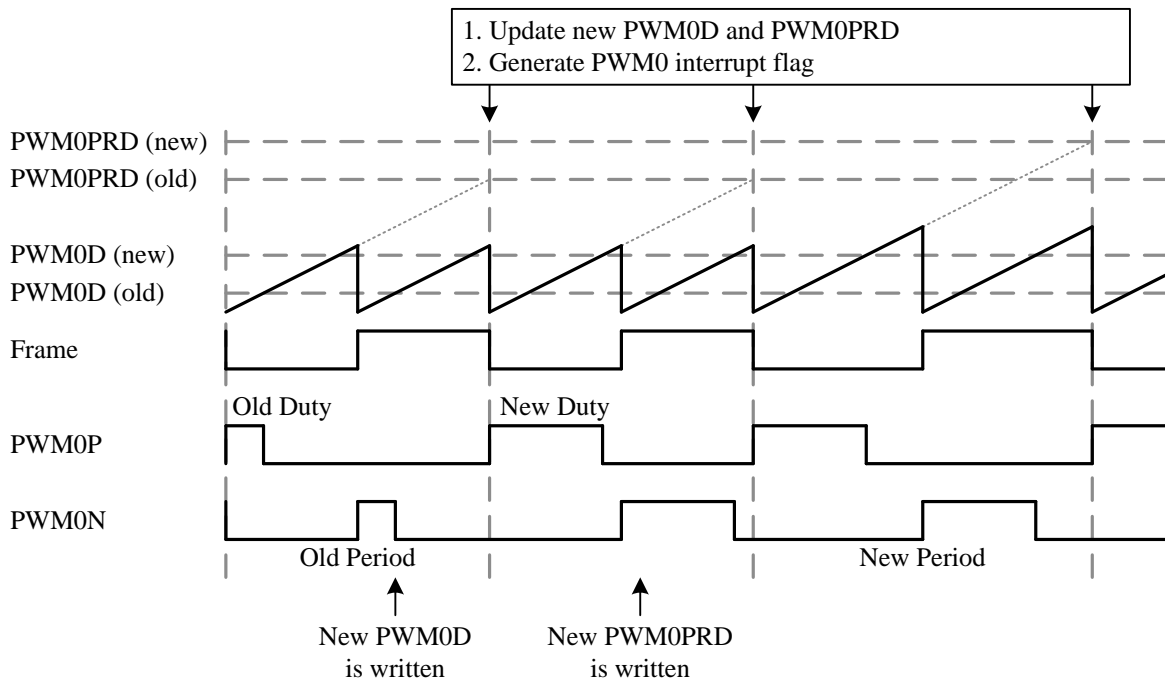

**PWM0 half-bridge mode output waveform (PWM0OM=0, PWM0DZ=0)**

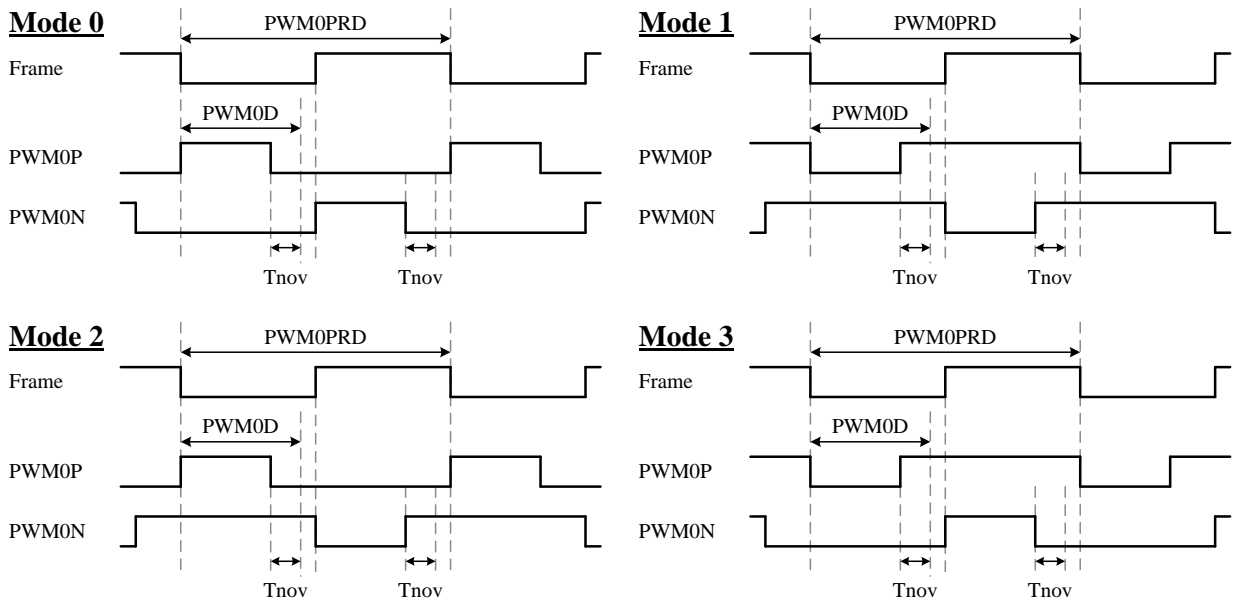

**PWM0 half-bridge mode output modes**

### 9.2 PWM1~PWM6

The Chip has six 16-bit PWM modules PWM1~PWM6. PWM1~6 are sharing period, clock source and interrupt (PWM1IF). The following takes PWM1 as an example for description. The PWM can generate varies frequency waveform with 65536 duty resolution on the basis of the PWM clock. The PWM clock can select double frequency (FRC x 2), FRC or  $F_{SYSCLK}$  as its clock source.

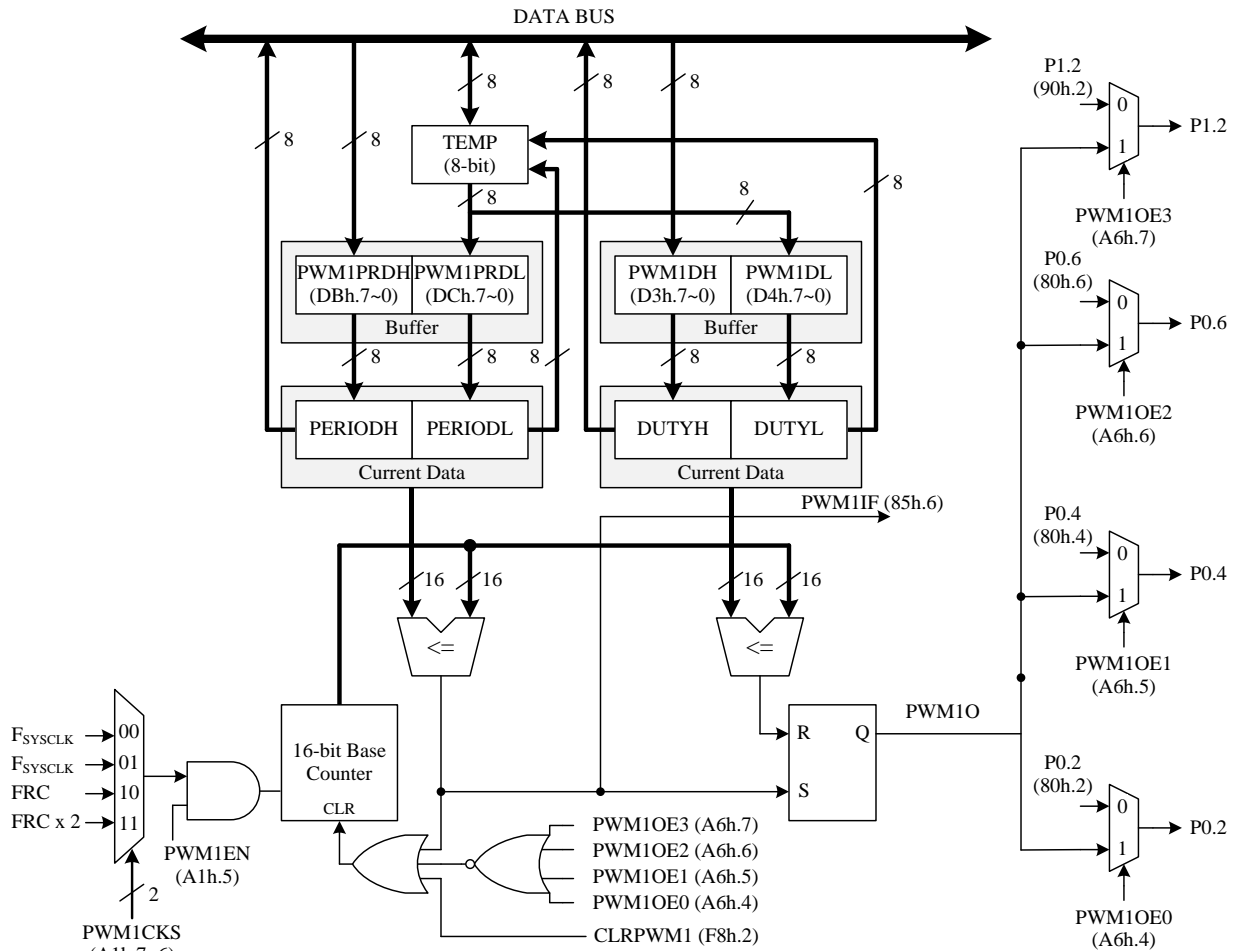

PWM1~6 Structure



SFR 84h	Bit 7	Bit 6	Bit 5	Bit 4	Bit 3	Bit 2	Bit 1	Bit 0
<b>INTE2</b>	–	PWM1IE	PWM0IE	–	–	–	TKBIE	TKAIE
R/W	–	R/W	R/W	–	–	–	R/W	R/W
Reset	–	0	0	–	–	–	0	0

84h.6 **PWM1IE:** PWM1~PWM6 interrupt enable  
 0: Disable PWM1~PWM6 interrupt  
 1: Enable PWM1~PWM6 interrupt

84h.5 **PWM0IE:** PWM0 interrupt enable  
 0: Disable PWM0 interrupt  
 1: Enable PWM0 interrupt

SFR 85h	Bit 7	Bit 6	Bit 5	Bit 4	Bit 3	Bit 2	Bit 1	Bit 0
<b>INTFLG2</b>	–	PWM1IF	PWM0IF	–	–	–	TKBIF	TKAIF
R/W	–	R/W	R/W	–	–	–	R/W	R/W
Reset	–	0	0	–	–	–	0	0

85h.6 **PWM1IF:** PWM1~PWM6 interrupt flag  
 Set by H/W at the end of PWM1 period, S/W writes BFh to INTFLG2 to clear this flag.

85h.5 **PWM0IF:** PWM0 interrupt enable  
 Set by H/W at the end of PWM0 period, S/W writes DFh to INTFLG2 to clear this flag.

SFR A9h	Bit 7	Bit 6	Bit 5	Bit 4	Bit 3	Bit 2	Bit 1	Bit 0
<b>INTE1</b>	PWMIE	CMPIE	LVDIE	SPI2CE	ADTKIE	EX2	PXIE	TM3IE
R/W	R/W	R/W	R/W	R/W	R/W	R/W	R/W	R/W
Reset	0	0	0	0	0	0	0	0

A9h.7 **PWMIE:** PWM0/PWM1~PWM6 interrupt enable  
 0: Disable PWM0/PWM1~PWM6 interrupt 1: Enable PWM0/PWM1~PWM6 interrupt

SFR A1h	Bit 7	Bit 6	Bit 5	Bit 4	Bit 3	Bit 2	Bit 1	Bit 0
<b>PWMCON</b>	PWM1CKS		PWM1EN	PWM0EN	PWM0CKS		PWM0NMSK	PWM0PMSK
R/W	R/W		R/W	R/W	R/W		R/W	R/W
Reset	0	0	0	0	0	0	0	0

A1h.7~6 **PWM1CKS:** PWM1~PWM6 clock source  
 00: F<sub>SYSClk</sub>  
 01: F<sub>SYSClk</sub>  
 10: FRC  
 11: FRCx2 (V<sub>cc</sub>>2.7V)

A1h.5 **PWM1EN:** PWM1~6 enable  
 0: PWM1~6 disable  
 1: PWM1~6 enable

A1h.4 **PWM0EN:** PWM0 enable  
 0: PWM0 disable  
 1: PWM0 enable

A1h.3~2 **PWM0CKS:** PWM0 clock source  
 00: F<sub>SYSClk</sub>  
 01: F<sub>SYSClk</sub>  
 10: FRC  
 11: FRCx2 (V<sub>cc</sub>>2.7V)

A1h.1 **PWM0NMSK:** PWM0N mask data. If CLRPWM0=1 and PMW0MSKE=1, PWM0N will output this mask data.

A1h.0 **PWM0PMSK:** PWM0P mask data. If CLRPWM0=1 and PMW0MSKE=1, PWM0P will output this mask data.

SFR A6h	Bit 7	Bit 6	Bit 5	Bit 4	Bit 3	Bit 2	Bit 1	Bit 0
<b>PWMOE0</b>	PWM1OE3	PWM1OE2	PWM1OE1	PWM1OE0	PWM0NOE1	PWM0POE1	PWM0NOE0	PWM0POE0
R/W	R/W	R/W	R/W	R/W	R/W	R/W	R/W	R/W
Reset	0	0	0	0	0	0	0	0

- A6h.7 **PWM1OE3**: PWM1 output control  
0: Disable      1: PWM1 enable and output to P1.2
- A6h.6 **PWM1OE2**: PWM1 output control  
0: Disable      1: PWM1 enable and output to P0.6
- A6h.5 **PWM1OE1**: PWM1 output control  
0: Disable      1: PWM1 enable and output to P0.4
- A6h.4 **PWM1OE0**: PWM1 output control  
0: Disable      1: PWM1 enable and output to P0.2
- A6h.3 **PWM0NOE1**: PWM0N output control  
0: Disable      1: PWM0N enable and output to P3.6
- A6h.2 **PWM0POE1**: PWM0P output control  
0: Disable      1: PWM0P enable and output to P3.5
- A6h.1 **PWM0NOE0**: PWM0N output control  
0: Disable      1: PWM0N enable and output to P0.4
- A6h.0 **PWM0POE0**: PWM0P output control  
0: Disable      1: PWM0P enable and output to P0.3

SFR A7h	Bit 7	Bit 6	Bit 5	Bit 4	Bit 3	Bit 2	Bit 1	Bit 0
<b>PWMCON2</b>	PWM0MOD	PWM0MSKE	PWM0OM		PWM0DZ			
R/W	R/W	R/W	R/W		R/W			
Reset	0	0	0	0	0	0	0	0

- A7h.7 **PWM0MOD**: PWM0 mode select  
0: Normal mode  
1: Half-bridge mode
- A7h.6 **PWM0MSKE**: PWM0 mask output enable  
0: Disable  
1: Enable, PWM0P/PWM0N output data by PWM0PMSK/PWM0NMSK while CLR PWM0=1
- A7h.5~4 **PWM0OM**: PWM0 output mode select  
00: Mode0  
01: Mode1  
10: Mode2  
11: Mode3
- A7h.3~0 **PWM0DZ**: PWM0 dead zone (Dead zone is prohibited in half-bridge mode)  
0000:  $0 \times T_{PWMCLK}$   
0001:  $1 \times T_{PWMCLK}$   
...  
1111:  $15 \times T_{PWMCLK}$

SFR B6h	Bit 7	Bit 6	Bit 5	Bit 4	Bit 3	Bit 2	Bit 1	Bit 0
<b>PWMOE1</b>	PWM4OE3	PWM4OE2	PWM4OE1	PWM4OE0	PWM3OE1	PWM3OE0	PWM2OE1	PWM2OE0
R/W	R/W	R/W	R/W	R/W	R/W	R/W	R/W	R/W
Reset	0	0	0	0	0	0	0	0

- B6h.7 **PWM4OE3**: PWM4 output control  
0: Disable 1: PWM4 enable and output to P3.6
- B6h.6 **PWM4OE2**: PWM4 output control  
0: Disable 1: PWM4 enable and output to P1.5
- B6h.5 **PWM4OE1**: PWM4 output control  
0: Disable 1: PWM4 enable and output to P0.4
- B6h.4 **PWM4OE0**: PWM4 output control  
0: Disable 1: PWM4 enable and output to P0.0
- B6h.3 **PWM3OE1**: PWM3 output control  
0: Disable 1: PWM3 enable and output to P3.4
- B6h.2 **PWM3OE0**: PWM3 output control  
0: Disable 1: PWM3 enable and output to P1.0
- B6h.1 **PWM2OE1**: PWM2 output control  
0: Disable 1: PWM2 enable and output to P3.6
- B6h.0 **PWM2OE0**: PWM2 output control  
0: Disable 1: PWM2 enable and output to P1.1

SFR B7h	Bit 7	Bit 6	Bit 5	Bit 4	Bit 3	Bit 2	Bit 1	Bit 0
<b>PWMOE2</b>	MSDASEL	MSCLSEL	PWM6OE2	PWM6OE1	PWM6OE0	PWM5OE2	PWM5OE1	PWM5OE0
R/W	R/W	R/W	R/W	R/W	R/W	R/W	R/W	R/W
Reset	0	0	0	0	0	0	0	0

- B7h.5 **PWM6OE2**: PWM6 output control  
0: Disable 1: PWM6 enable and output to P1.3
- B7h.4 **PWM6OE1**: PWM6 output control  
0: Disable 1: PWM6 enable and output to P0.7
- B7h.3 **PWM6OE0**: PWM6 output control  
0: Disable 1: PWM6 enable and output to P0.3
- B7h.2 **PWM5OE2**: PWM5 output control  
0: Disable 1: PWM5 enable and output to P1.4
- B7h.1 **PWM5OE1**: PWM5 output control  
0: Disable 1: PWM5 enable and output to P0.6
- B7h.0 **PWM5OE0**: PWM5 output control  
0: Disable 1: PWM5 enable and output to P0.1

SFR D1h	Bit 7	Bit 6	Bit 5	Bit 4	Bit 3	Bit 2	Bit 1	Bit 0
<b>PWM0DH</b>	PWM0DH							
R/W	R/W							
Reset	0	0	0	0	0	0	0	0

- D1h.7~0 **PWM0DH**: PWM0 duty high byte  
write sequence: PWMxDL then PWMxDH  
read sequence: PWMxDH then PWMxDL

SFR D2h	Bit 7	Bit 6	Bit 5	Bit 4	Bit 3	Bit 2	Bit 1	Bit 0
<b>PWM0DL</b>	PWM0DL							
R/W	R/W							
Reset	0	0	0	0	0	0	0	0

D2h.7~0 **PWM0DL**: PWM0 duty low byte  
 write sequence: PWMxDL then PWMxDH  
 read sequence: PWMxDH then PWMxDL

SFR D3h	Bit 7	Bit 6	Bit 5	Bit 4	Bit 3	Bit 2	Bit 1	Bit 0
<b>PWM1DH</b>	PWM1DH							
R/W	R/W							
Reset	0	0	0	0	0	0	0	0

D3h.7~0 **PWM1DH**: PWM1 duty high byte  
 write sequence: PWMxDL then PWMxDH  
 read sequence: PWMxDH then PWMxDL

SFR D4h	Bit 7	Bit 6	Bit 5	Bit 4	Bit 3	Bit 2	Bit 1	Bit 0
<b>PWM1DL</b>	PWM1DL							
R/W	R/W							
Reset	0	0	0	0	0	0	0	0

D4h.7~0 **PWM1DL**: PWM1 duty low byte  
 write sequence: PWMxDL then PWMxDH  
 read sequence: PWMxDH then PWMxDL

SFR D5h	Bit 7	Bit 6	Bit 5	Bit 4	Bit 3	Bit 2	Bit 1	Bit 0
<b>PWM2DH</b>	PWM2DH							
R/W	R/W							
Reset	0	0	0	0	0	0	0	0

D5h.7~0 **PWM2DH**: PWM2 duty high byte  
 write sequence: PWMxDL then PWMxDH  
 read sequence: PWMxDH then PWMxDL

SFR D6h	Bit 7	Bit 6	Bit 5	Bit 4	Bit 3	Bit 2	Bit 1	Bit 0
<b>PWM2DL</b>	PWM2DL							
R/W	R/W							
Reset	0	0	0	0	0	0	0	0

D6h.7~0 **PWM2DL**: PWM2 duty low byte  
 write sequence: PWMxDL then PWMxDH  
 read sequence: PWMxDH then PWMxDL

SFR D9h	Bit 7	Bit 6	Bit 5	Bit 4	Bit 3	Bit 2	Bit 1	Bit 0
<b>PWM0PRDH</b>	PWM0PRDH							
R/W	R/W							
Reset	1	1	1	1	1	1	1	1

D9h.7~0 **PWM0PRDH**: PWM0 period high byte  
 write sequence: PWMxPRDL then PWMxPRDH  
 read sequence: PWMxPRDH then PWMxPRDL

SFR DAh	Bit 7	Bit 6	Bit 5	Bit 4	Bit 3	Bit 2	Bit 1	Bit 0
<b>PWM0PRDL</b>	PWM0PRDL							
R/W	R/W							
Reset	1	1	1	1	1	1	1	1

DAh.7~0 **PWM0PRDL**: PWM0 period low byte  
 write sequence: PWMxPRDL then PWMxPRDH  
 read sequence: PWMxPRDH then PWMxPRDL

SFR DBh	Bit 7	Bit 6	Bit 5	Bit 4	Bit 3	Bit 2	Bit 1	Bit 0
<b>PWM1PRDH</b>	PWM1PRDH							
R/W	R/W							
Reset	1	1	1	1	1	1	1	1

DBh.7~0 **PWM1PRDH**: PWM1/PWM2/PWM3/PWM4/PWM5/PWM6 period high byte  
 write sequence: PWMxPRDL then PWMxPRDH  
 read sequence: PWMxPRDH then PWMxPRDL

SFR DCh	Bit 7	Bit 6	Bit 5	Bit 4	Bit 3	Bit 2	Bit 1	Bit 0
<b>PWM1PRDL</b>	PWM1PRDL							
R/W	R/W							
Reset	1	1	1	1	1	1	1	1

DCh.7~0 **PWM1PRDL**: PWM1/PWM2/PWM3/PWM4/PWM5/PWM6 period low byte  
 write sequence: PWMxPRDL then PWMxPRDH  
 read sequence: PWMxPRDH then PWMxPRDL

SFR DDh	Bit 7	Bit 6	Bit 5	Bit 4	Bit 3	Bit 2	Bit 1	Bit 0
<b>PWM3DH</b>	PWM3DH							
R/W	R/W							
Reset	0	0	0	0	0	0	0	0

DDh.7~0 **PWM3DH**: PWM3 duty high byte  
 write sequence: PWMxDL then PWMxDH  
 read sequence: PWMxDH then PWMxDL

SFR DEh	Bit 7	Bit 6	Bit 5	Bit 4	Bit 3	Bit 2	Bit 1	Bit 0
<b>PWM3DL</b>	PWM3DL							
R/W	R/W							
Reset	0	0	0	0	0	0	0	0

DEh.7~0 **PWM3DL**: PWM3 duty low byte  
 write sequence: PWMxDL then PWMxDH  
 read sequence: PWMxDH then PWMxDL

SFR E9h	Bit 7	Bit 6	Bit 5	Bit 4	Bit 3	Bit 2	Bit 1	Bit 0
<b>PWM4DH</b>	PWM4DH							
R/W	R/W							
Reset	0	0	0	0	0	0	0	0

E9h.7~0 **PWM4DH**: PWM4 duty high byte  
 write sequence: PWMxDL then PWMxDH  
 read sequence: PWMxDH then PWMxDL

SFR EAh	Bit 7	Bit 6	Bit 5	Bit 4	Bit 3	Bit 2	Bit 1	Bit 0
<b>PWM4DL</b>	PWM4DL							
R/W	R/W							
Reset	0	0	0	0	0	0	0	0

EAh.7~0 **PWM4DL**: PWM4 duty low byte  
 write sequence: PWMxDL then PWMxDH  
 read sequence: PWMxDH then PWMxDL

SFR EBh	Bit 7	Bit 6	Bit 5	Bit 4	Bit 3	Bit 2	Bit 1	Bit 0
<b>PWM5DH</b>	PWM5DH							
R/W	R/W							
Reset	0	0	0	0	0	0	0	0

EBh.7~0 **PWM5DH**: PWM5 duty high byte  
 write sequence: PWMxDL then PWMxDH  
 read sequence: PWMxDH then PWMxDL

SFR ECh	Bit 7	Bit 6	Bit 5	Bit 4	Bit 3	Bit 2	Bit 1	Bit 0
<b>PWM5DL</b>	PWM5DL							
R/W	R/W							
Reset	0	0	0	0	0	0	0	0

ECh.7~0 **PWM5DL**: PWM5 duty low byte  
 write sequence: PWMxDL then PWMxDH  
 read sequence: PWMxDH then PWMxDL

SFR EDh	Bit 7	Bit 6	Bit 5	Bit 4	Bit 3	Bit 2	Bit 1	Bit 0
<b>PWM6DH</b>	PWM6DH							
R/W	R/W							
Reset	0	0	0	0	0	0	0	0

EDh.7~0 **PWM6DH**: PWM6 duty high byte  
 write sequence: PWMxDL then PWMxDH  
 read sequence: PWMxDH then PWMxDL

SFR EEh	Bit 7	Bit 6	Bit 5	Bit 4	Bit 3	Bit 2	Bit 1	Bit 0
<b>PWM6DL</b>	PWM6DL							
R/W	R/W							
Reset	0	0	0	0	0	0	0	0

EEh.7~0 **PWM6DL**: PWM6 duty low byte  
 write sequence: PWMxDL then PWMxDH  
 read sequence: PWMxDH then PWMxDL

SFR F8h	Bit 7	Bit 6	Bit 5	Bit 4	Bit 3	Bit 2	Bit 1	Bit 0
<b>AUX1</b>	CLRWDT	CLRTM3	–	ADSOC	CLRPWM0	CLRPWM1	LDLOCOUT	DPSEL
R/W	R/W	R/W	–	R/W	R/W	R/W	R/W	R/W
Reset	0	0	–	0	1	1	0	0

F8h.3 **CLRPWM0**: PWM0 clear enable  
 0: PWM0 is running  
 1: PWM0 is cleared and held

F8h.2 **CLRPWM1**: PWM1/PWM2/PWM3/PWM4/PWM5/PWM6 clear enable  
 0: PWM1/PWM2/PWM3/PWM4/PWM5/PWM6 is running  
 1: PWM1/PWM2/PWM3/PWM4/PWM5/PWM6 is cleared and held

## 10. Touch Key

Touch Key provides a simple and reliable method to achieve finger touch detection. In most applications, it does not require any external components. The device supports 8-channel touch key detection.

To use the Touch Key, user must setup the Pin Mode (*see Section 6*) correctly as below table. Touch Key Pin need to set CMOS output Low (Pin Mode2) to reduce the mutual interference between the adjacent keys.

PxMOD setting for TK0~TK7	TK PIN
Pin is Touch Key, Idling	Drive Low (Pin Mode2)
Pin is Touch Key, Scanning	

There are two oscillators: Reference Clock (RCK) and Touch Clock (TCK). They are connected to the Reference Counter and Data Counter respectively. The frequency of RCK can be adjusted by setting TKxREFC. Reference Counter is used to control conversion time. From starting touch key conversion to end, it will take 0 to 16384 RCK oscillation cycles by setting TKxTMR. After end of conversion, user can get TK data (TKxDH, TKxDL) from Data counter. TK data is affected by finger touching. As finger touching TCK is getting slower, the value of TK data is smaller than the no finger touching. According to the difference of TK data, user can check if it is touched or not. User can choose TK channel by TKxCHS. TK7 is connected a internal built-in reference capacitor, and its capacitance is selected by TKBKCP.

To start the Scanning, user assigns TKxPD=0, then set the TKxSOC bit to start touch key conversion, the TKxSOC bit can be automatically cleared after TKxEOC rising. TKxEOC=0 means conversion is in process, TKxEOC=1 means the conversion is finish, and the touch key counting result is stored into the 14-bit TK Data Counter TKxDH and TKxDL.

TKIF will active at the first time enable Touch Key function (TKxPD=0), user should clear TKIF after TKxPD cleared.

When TKxPD=0, and TKxCHS is set, the Touch Key module is connected to the I/O port through the selection of TKxCHS. If the I/O port is used as other functions, it must be affected. Therefore, when the Touch Key module is not in use, it is recommended to set TKxPD =1 to disconnect the TK module from the I/O port.

Example:

```

MOV      TKCON, #4Ch      ; TKAPD=0, TKBPD=1
;
MOV      TKATMRH, #04h    ;
MOV      TKATMRL, #00h    ; TKATMR=400h
MOV      TKCHS, #33h      ; TKA channel select is TK3
MOV      INTFLG, #DFh     ; Clear TKIF
ORL      INTE1, #08h      ; ADTKIE=1
ORL      IE, #80h         ; EA=1
ORL      TKCON, #20h      ; TKASOC=1
    
```

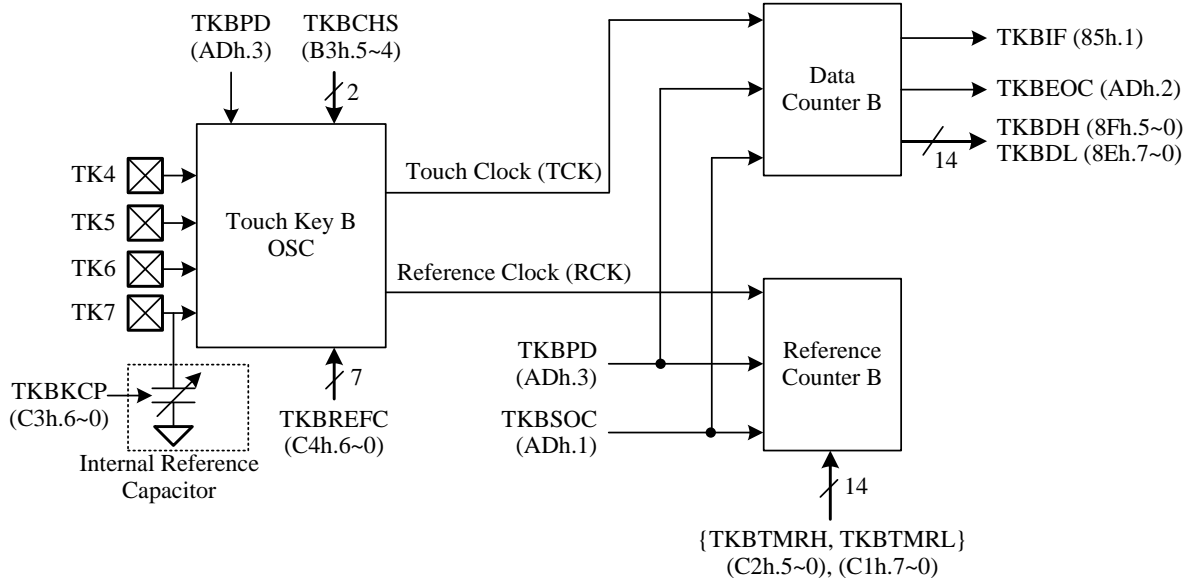
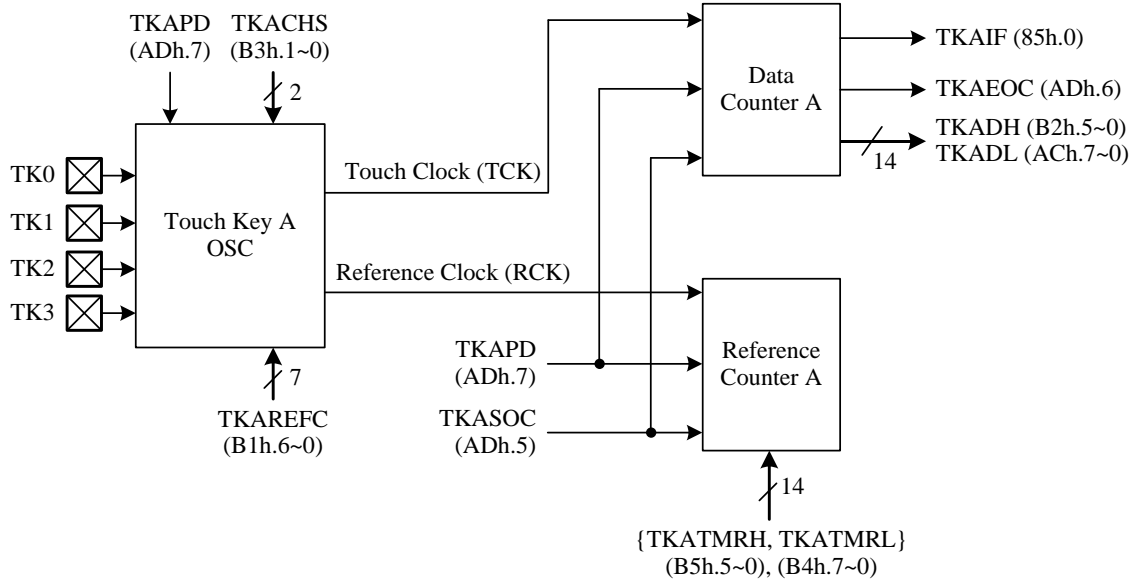
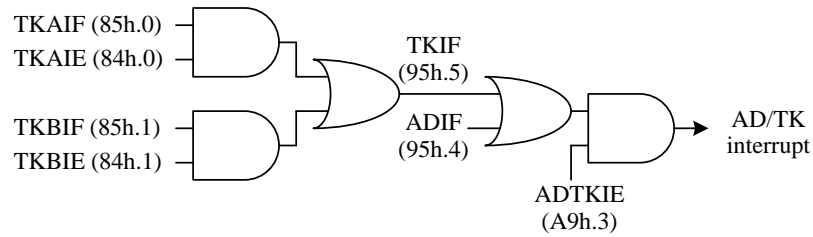
**Touch Key Structure**



FR 84h	Bit 7	Bit 6	Bit 5	Bit 4	Bit 3	Bit 2	Bit 1	Bit 0
<b>INTE2</b>	–	PWM1IE	PWM0IE	–	–	–	TKBIE	TKAIE
R/W	–	R/W	R/W	–	–	–	R/W	R/W
Reset	–	0	0	–	–	–	0	0

- 84h.1 **TKBIE:** Touch Key B interrupt enable  
 0: Disable Touch Key B interrupt  
 1: Enable Touch Key B interrupt
- 84h.0 **TKAIE:** Touch Key A interrupt enable  
 0: Disable Touch Key A interrupt  
 1: Enable Touch Key A interrupt

SFR 85h	Bit 7	Bit 6	Bit 5	Bit 4	Bit 3	Bit 2	Bit 1	Bit 0
<b>INTFLG2</b>	–	PWM1IF	PWM0IF	–	–	–	TKBIF	TKAIF
R/W	–	R/W	R/W	–	–	–	R/W	R/W
Reset	–	0	0	–	–	–	0	0

- 85h.1 **TKBIF:** Touch Key B interrupt flag  
 Set by H/W at the end of Touch Key B scan, S/W writes FDh to INTFLG2 to clear this flag.
- 85h.0 **TKAIF:** Touch Key A interrupt flag  
 Set by H/W at the end of Touch Key A scan, S/W writes FEh to INTFLG2 to clear this flag.

SFR 95h	Bit 7	Bit 6	Bit 5	Bit 4	Bit 3	Bit 2	Bit 1	Bit 0
<b>INTFLG</b>	LVD	CMPIF	TKIF	ADIF	–	IE2	PXIF	TF3
R/W	R/W	R/W	R/W	R/W	–	R/W	R/W	R/W
Reset	0	0	0	0	–	0	0	0

- 95h.5 **TKIF:** Touch Key Interrupt Flag  
 Set by H/W at the end of Touch Key conversion. S/W writes DFh to INTFLG or sets the TKSOC bit to clear this flag. When user clears this flag, H/W will automatically clear TKAIF and TKBIF.

SFR A9h	Bit 7	Bit 6	Bit 5	Bit 4	Bit 3	Bit 2	Bit 1	Bit 0
<b>INTE1</b>	PWMIE	CMPIE	LVDIE	SPI2CE	ADTKIE	EX2	PXIE	TM3IE
R/W	R/W	R/W	R/W	R/W	R/W	R/W	R/W	R/W
Reset	0	0	0	0	0	0	0	0

- A9h.3 **ADTKIE:** ADC interrupt enable  
 0: Disable ADC/TK interrupt 1: Enable ADC/TK interrupt

SFR 8Eh	Bit 7	Bit 6	Bit 5	Bit 4	Bit 3	Bit 2	Bit 1	Bit 0
<b>TKBDL</b>	TKBDL							
R/W	R							
Reset	–	–	–	–	–	–	–	–

- 8Eh.7~0 **TKBDL:** Touch Key B data low byte

SFR 8Fh	Bit 7	Bit 6	Bit 5	Bit 4	Bit 3	Bit 2	Bit 1	Bit 0
<b>TKBDH</b>	–	–	TKBDH					
R/W	–	–	R					
Reset	–	–	–	–	–	–	–	–

- 8Fh.5~0 **TKBDH:** Touch Key B data high byte

SFR Ach	Bit 7	Bit 6	Bit 5	Bit 4	Bit 3	Bit 2	Bit 1	Bit 0
<b>TKADL</b>	TKADL							
R/W	R							
Reset	–	–	–	–	–	–	–	–

ACh.7~0 **TKADL**: Touch Key A data low byte

SFR ADh	Bit 7	Bit 6	Bit 5	Bit 4	Bit 3	Bit 2	Bit 1	Bit 0
<b>TKCON</b>	TKAPD	TKAEOC	TKASOC	–	TKBPD	TKBEOC	TKBSOC	–
R/W	R/W	R/W	R/W	–	R/W	R/W	R/W	–
Reset	1	1	0	0	1	1	0	0

- ADh.7 **TKAPD**: Touch Key A power down.
- ADh.6 **TKAEOC**: Touch Key A end of conversion.
- ADh.5 **TKASOC**: Touch Key A start, HW clear while end of conversion.
- ADh.3 **TKBPD**: Touch Key B power down.
- ADh.2 **TKBEOC**: Touch Key B end of conversion.
- ADh.1 **TKBSOC**: Touch Key B start, HW clear while end of conversion.

SFR B1h	Bit 7	Bit 6	Bit 5	Bit 4	Bit 3	Bit 2	Bit 1	Bit 0
<b>TKAREFC</b>	–	TKAREFC						
R/W	–	R/W						
Reset	–	–	–	–	–	–	–	–

B1h.6~0 **TKAREFC**: Touch Key A reference clock capacitor select

SFR B2h	Bit 7	Bit 6	Bit 5	Bit 4	Bit 3	Bit 2	Bit 1	Bit 0
<b>TKADH</b>	–	–	TKADH					
R/W	–	–	R					
Reset	–	–	–	–	–	–	–	–

B2h.5~0 **TKADH**: Touch Key A data high byte

SFR B3h	Bit 7	Bit 6	Bit 5	Bit 4	Bit 3	Bit 2	Bit 1	Bit 0
<b>TKCHS</b>	–	–	TKBCHS		–	–	TKACHS	
R/W	R/W	R/W	R/W		R/W	R/W	R/W	
Reset	0	0	0	0	0	0	0	0

- B3h.5~4 **TKBCHS**: Touch Key B channel select
  - 00: TK4 (P1.1)
  - 01: TK5 (P0.5)
  - 10: TK6 (P0.6)
  - 11: TK7 (P0.7) (Ref)
- B3h.1~0 **TKACHS**: Touch Key A channel select
  - 00: TK0 (P3.7)
  - 01: TK1 (P2.1)
  - 10: TK2 (P2.0)
  - 11: TK3 (P1.2)

SFR B4h	Bit 7	Bit 6	Bit 5	Bit 4	Bit 3	Bit 2	Bit 1	Bit 0
<b>TKATMRL</b>	TKATMRL							
R/W	R/W							
Reset	1	1	1	1	1	1	1	1

B4h.7~0 **TKATMRL**: Touch Key A reference counter data 7~0

SFR B5h	Bit 7	Bit 6	Bit 5	Bit 4	Bit 3	Bit 2	Bit 1	Bit 0
<b>TKATMRH</b>	TKATMRH							
R/W	R/W							
Reset	0	0	0	0	0	0	0	0

B5h.5~0 **TKATMRH**: Touch Key A reference counter data 13~8

SFR C1h	Bit 7	Bit 6	Bit 5	Bit 4	Bit 3	Bit 2	Bit 1	Bit 0
<b>TKBTMRL</b>	TKBTMRL							
R/W	R/W							
Reset	1	1	1	1	1	1	1	1

C1h.7~0 **TKBTMRL**: Touch Key B reference counter data 7~0

SFR C2h	Bit 7	Bit 6	Bit 5	Bit 4	Bit 3	Bit 2	Bit 1	Bit 0
<b>TKBTMRH</b>	TKBTMRH							
R/W	R/W							
Reset	0	0	0	0	0	0	0	0

C2h.5~0 **TKBTMRH**: Touch Key B reference counter data 13~8

SFR C3h	Bit 7	Bit 6	Bit 5	Bit 4	Bit 3	Bit 2	Bit 1	Bit 0
<b>TKBKCP</b>	TKBKCP							
R/W	R/W							
Reset	-	-	-	-	-	-	-	-

C3h.6~0 **TKBKCP**: Touch Key B reference capacitor select (TK7)

SFR C4h	Bit 7	Bit 6	Bit 5	Bit 4	Bit 3	Bit 2	Bit 1	Bit 0
<b>TKBREFC</b>	TKBREFC							
R/W	R/W							
Reset	-	-	-	-	-	-	-	-

C4h.6~0 **TKBREFC**: Touch Key B reference clock capacitor select

**11. Low Voltage Detection (LVD)**

The chip also provides a low voltage detection (LVD) function, and the SFR LVDSEL can select 15 LVDs with different voltage thresholds.

LVDPD (SFR E4h.4)	Operation Mode	PWRSV (SFR F7.5)	LVDSEL (SFR E4h.3~0)	Function
1	X	X	X	LVD disable
0	Fast/Slow	X	0000	LVD 2.05V
			0001	LVD 2.19V
			0010	LVD 2.33V
			0011	LVD 2.47V
			0100	LVD 2.61V
			0101	LVD 2.75V
			0110	LVD 2.89V
			0111	LVD 3.03V
			1000	LVD 3.17V
			1001	LVD 3.31V
			1010	LVD 3.45V
			1011	LVD 3.59V
			1100	LVD 3.73V
			1101	LVD 3.87V
			1110	LVD 4.01V
	1111	LVD 4.15V		
	Idle/Halt/Stop	0	0000	LVD 2.05V
			0001	LVD 2.19V
			0010	LVD 2.33V
			0011	LVD 2.47V
			0100	LVD 2.61V
			0101	LVD 2.75V
			0110	LVD 2.89V
			0111	LVD 3.03V
			1000	LVD 3.17V
			1001	LVD 3.31V
			1010	LVD 3.45V
			1011	LVD 3.59V
			1100	LVD 3.73V
			1101	LVD 3.87V
1110			LVD 4.01V	
1111	LVD 4.15V			
Idle/Halt/Stop	1	xxxx	LVD disable	

**Low voltage detect table**

SFR E4h	Bit 7	Bit 6	Bit 5	Bit 4	Bit 3	Bit 2	Bit 1	Bit 0
<b>LVDCON</b>	LVDM	LVDO	LVDHYS	LVDPD	LVDSSEL			
R/W	R/W	R	R/W	R/W	R/W	R/W	R/W	R/W
Reset	0	0	0	0	0	0	0	0

- E4h.7 **LVDM:**  
 0: VCC < VLVD (LVDIF = 1 while LVDO = 1)  
 1: VCC > VLVD (LVDIF = 1 while LVDO = 0)
- E4h.6 **LVDO:** LVD real-time Output
- E4h.5 **LVDHYS:** LVD Hysteresis Enable.  
 0: LVD Hysteresis disable  
 1: LVD Hysteresis enable
- E4h.4 **LVDPD:** LVD Power Down.  
 0: LVD Enable  
 1: LVD Disable
- E4h.3~0 **LVDSSEL:** Low Voltage Detect (LVD) select. (step=0.14V)  
 0000: Set LVD at 2.05V  
 0001: Set LVD at 2.19V  
 0010: Set LVD at 2.33V  
 0011: Set LVD at 2.47V  
 0100: Set LVD at 2.61V  
 0101: Set LVD at 2.75V  
 0110: Set LVD at 2.89V  
 0111: Set LVD at 3.03V  
 1000: Set LVD at 3.17V  
 1001: Set LVD at 3.31V  
 1010: Set LVD at 3.45V  
 1011: Set LVD at 3.59V  
 1100: Set LVD at 3.73V  
 1101: Set LVD at 3.87V  
 1110: Set LVD at 4.01V  
 1111: Set LVD at 4.15V

SFR F7h	Bit 7	Bit 6	Bit 5	Bit 4	Bit 3	Bit 2	Bit 1	Bit 0
<b>AUX2</b>	WDTE		PWRSVAV	VBGOUT	DIV32	IAPTE		MULDIV16
R/W	R/W	R/W	R/W	R/W	R/W	R/W		R/W
Reset	0	0	0	0	0	1	1	0

- F7h.5 **PWRSVAV:** Set 1 to reduce the chip's power consumption at Idle/Halt/Stop Mode

## 12. ADC

The Chip offers a 12-bit ADC consisting of a 19-channel analog input multiplexer, control register, clock generator, 12-bit successive approximation register, and output data register. Generally, ADC clock frequency is less than 1 MHz, user can refer to Electrical Characteristics Chapter for detail.

To use the ADC, set the ADCKS bits first to choose a proper ADC clock frequency. Then, user launch the ADC conversion by setting the ADSOC bit, and H/W will automatic clear it at the end of the conversion. After the end of the conversion, H/W will set the ADIF bit and generate an interrupt if an ADC interrupt is enabled. The ADIF bit can be cleared by writing 0 to this bit or set ADSOC bit. The analog input level must remain within the range from  $V_{SS}$  to  $V_{CC}$ .

Using the ADCVREFS option, the ADC internal reference voltage source (VREF) can be selected as  $V_{CC}$  or VBG 2.49V. When ADCVREFS=1, VBGSEL must be set to 2'b01.

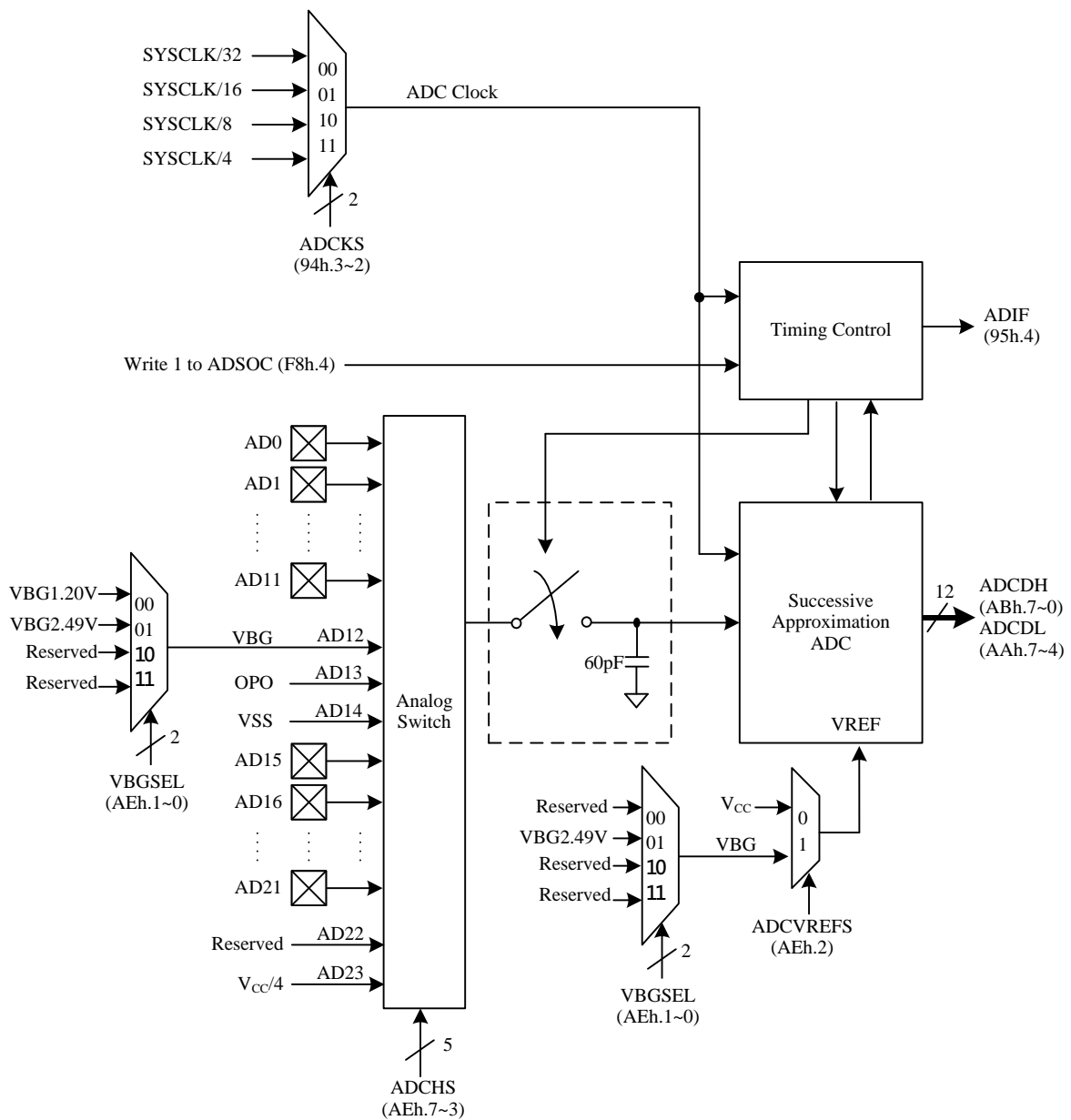

**ADC Structure**

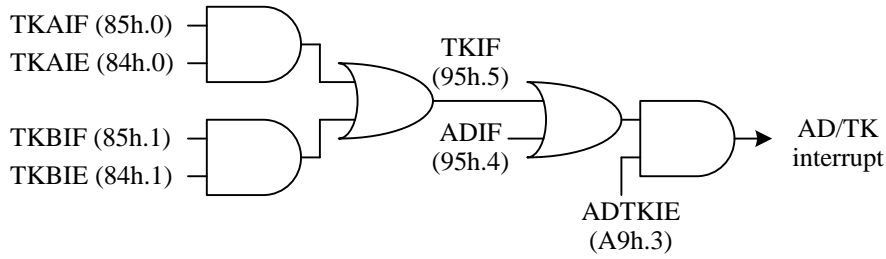

ADC Interrupt Structure

### ADC Channels

The ADC channels are connected to the analog input pins via the analog switch multiplexer. The analog switch multiplexer is controlled by ADCHS register. The Chip offers up to 19 IO input pins, designated AD0~AD11, AD15~AD21. In addition, there are 3 internal reference voltages (VBG, VSS, V<sub>CC</sub>/4). When ADCHS is set to 1100b, the analog input will connect to VBG, and when ADCHS is set to 1101b, the analog input will connect to OPO, generated from internal operational amplifier.

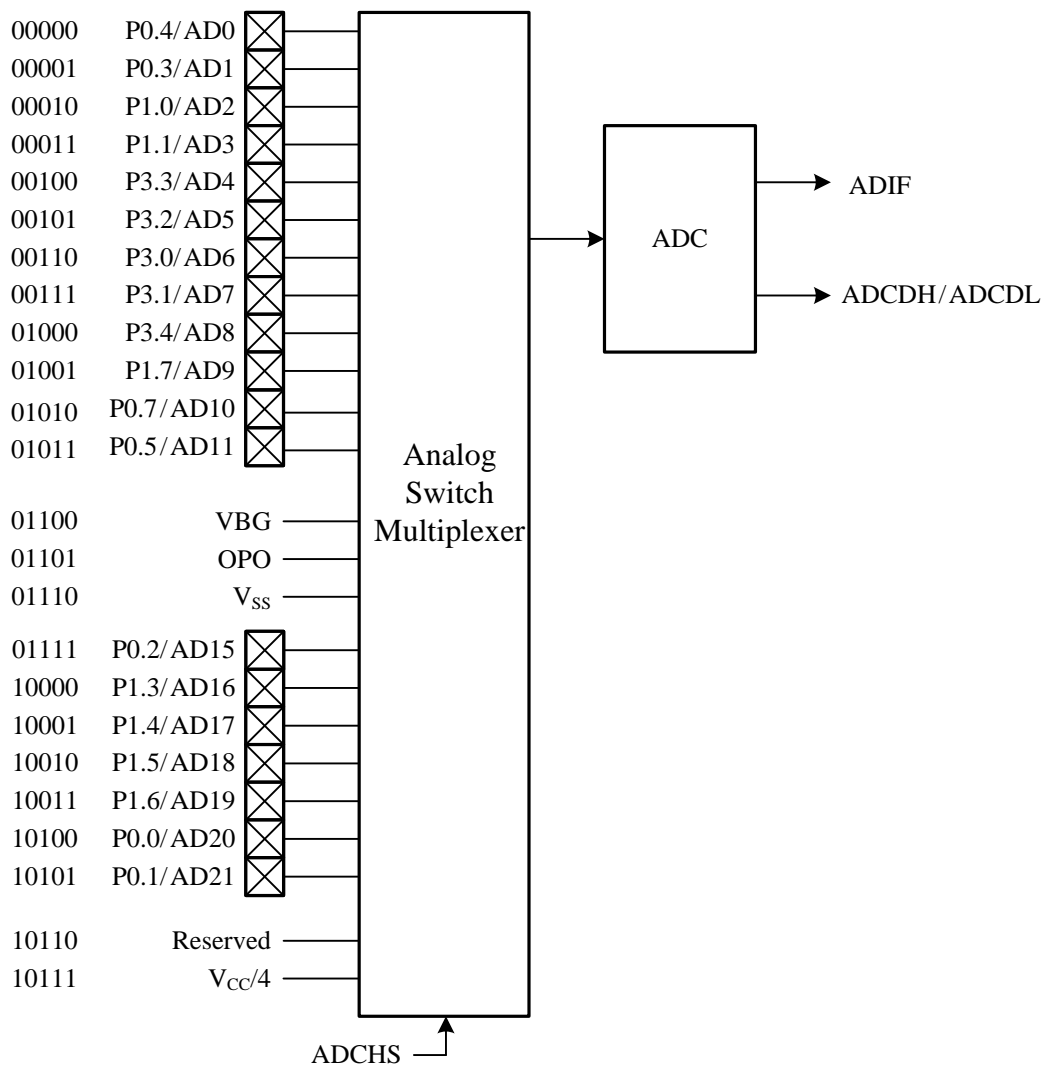

### ADC Conversion Time

The conversion time is the time required for the ADC to convert the voltage. The ADC requires two ADC clock cycles to convert each bit and several clock cycles to sample and hold the input voltage. A total of 42 ADC clock cycles are required to perform the complete conversion. When the conversion time is complete, the ADIF interrupt flag is set by H/W, and the result is loaded into the ADCDH and ADCDL registers of the 12-bit A/D result.

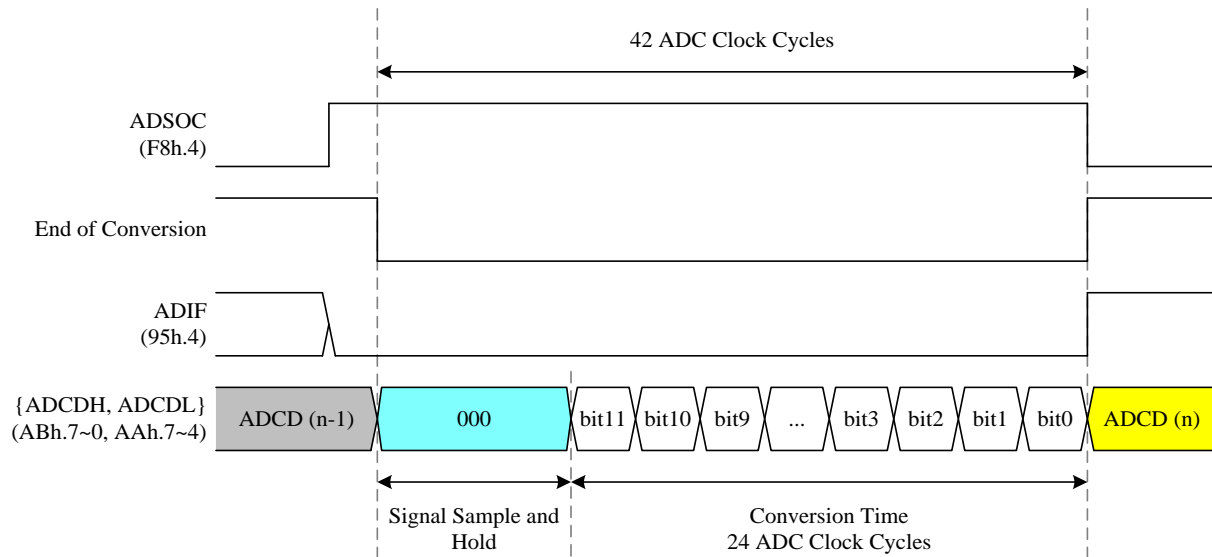

SFR 94h	Bit 7	Bit 6	Bit 5	Bit 4	Bit 3	Bit 2	Bit 1	Bit 0
<b>OPTION</b>	UART1W	TM3CKS	WDTPSC		ADCKS		TM3PSC	
R/W	R/W	R/W	R/W		R/W		R/W	
Reset	0	0	0	0	0	0	0	0

94h.3~2 **ADCKS:** ADC clock rate select

- 00:  $F_{SYSCLK}/32$
- 01:  $F_{SYSCLK}/16$
- 10:  $F_{SYSCLK}/8$
- 11:  $F_{SYSCLK}/4$

SFR 95h	Bit 7	Bit 6	Bit 5	Bit 4	Bit 3	Bit 2	Bit 1	Bit 0
<b>INTFLG</b>	LVDIF	CMPIF	TKIF	ADIF	–	IE2	PXIF	TF3
R/W	R/W	R/W	R/W	R/W	–	R/W	R/W	R/W
Reset	0	0	0	0	–	0	0	0

95h.4 **ADIF:** ADC interrupt flag

Set by H/W at the end of ADC conversion. S/W writes EFh to INTFLG or sets the ADSOC bit to clear this flag.

SFR AAh	Bit 7	Bit 6	Bit 5	Bit 4	Bit 3	Bit 2	Bit 1	Bit 0
<b>ADCDL</b>	ADCDL				–	–	–	–
R/W	R				–	–	–	–
Reset	–	–	–	–	–	–	–	–

AAh.7~4 **ADCDL:** ADC data bit 3~0



SFR ABh	Bit 7	Bit 6	Bit 5	Bit 4	Bit 3	Bit 2	Bit 1	Bit 0
<b>ADCDH</b>	ADCDH							
R/W	R							
Reset	–	–	–	–	–	–	–	–

ABh.7~0 **ADCDH**: ADC data bit 11~4

SFR AEh	Bit 7	Bit 6	Bit 5	Bit 4	Bit 3	Bit 2	Bit 1	Bit 0
<b>CHSEL</b>	ADCHS					ADCVREFS	VBGSEL	
R/W	R/W					R/W	R/W	
Reset	1	1	1	1	1	0	0	0

AEh.7~3 **ADCHS**: ADC channel select

00000: ADC0 (P04)	01101: OPO
00001: ADC1 (P03)	01110: VSS
00010: ADC2 (P10)	01111: ADC15 (P02)
00011: ADC3 (P11)	10000: ADC16 (P13)
00100: ADC4 (P33)	10001: ADC17 (P14)
00101: ADC5 (P32)	10010: ADC18 (P15)
00110: ADC6 (P30)	10011: ADC19 (P16)
00111: ADC7 (P31)	10100: ADC20 (P00)
01000: ADC8 (P34)	10101: ADC21 (P01)
01001: ADC9 (P17)	10110: Reserved
01010: ADC10 (P07)	10111: VCC/4
01011: ADC11 (P05)	other: Reserved
01100: VBGO	

AEh.2 **ADCVREFS**: ADC reference voltage select

- 0: V<sub>CC</sub>
- 1: VBG

AEh.1~0 **VBGSEL**: VBG voltage select

When ADCVREF is selected as VBG, VBGSEL is prohibited from using 1.20V.

- 00: 1.20V
- 01: 2.49V (need V<sub>CC</sub>>2.8V)
- 10: Reserved
- 11: Reserved

SFR F8h	Bit 7	Bit 6	Bit 5	Bit 4	Bit 3	Bit 2	Bit 1	Bit 0
<b>AUX1</b>	CLRWDT	CLRMTM3	–	ADSOC	CLRPWM0	CLRPWM1	LDOCOUT	DPSEL
R/W	R/W	R/W	–	R/W	R/W	R/W	R/W	R/W
Reset	0	0	–	0	1	1	0	0

F8h.4 **ADSOC**: Start ADC conversion

Set the ADSOC bit to start ADC conversion, and the ADSOC bit will be cleared by H/W at the end of conversion. S/W can also write 0 to clear this flag.

*Note: See also Chapter 5 for more information on ADC interrupt enable and priority.*

*Note: Also refer to Chapter 6 for details on ADC pin input settings.*

### 13. S/W Controller LCD Driver

The chip supports an S/W controlled method to driving LCD. It is capable of driving the LCD panel with 88 dots (Max.) by 4 Commons (COM) and 22 Segments (SEG). The P1.2~P1.5 are used for Common pins COM0~COM3 and others pins can be used for Segment pins. COM0~COM3 are capable of driving 1/2 bias when P1.2~P1.5's P1LOE=1. Refer to the following figures.

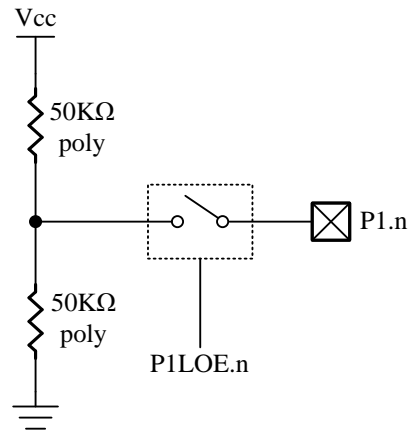

**LCD COM0~3 Circuit**

The frequency of any repeating waveform output on the COM pin can be used to represent the LCD frame rate. The figure below shows an LCD frame.

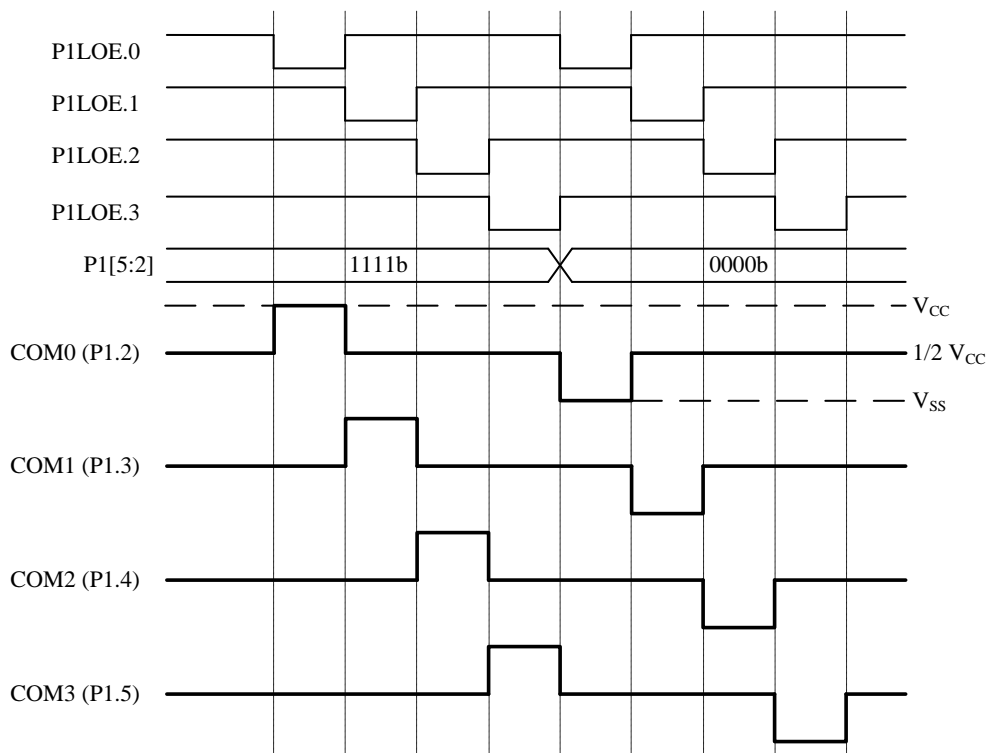

**S/W Controlled LCD COM0~3 Scanning**

1/4 Duty, 1/2 Bias Output Waveform

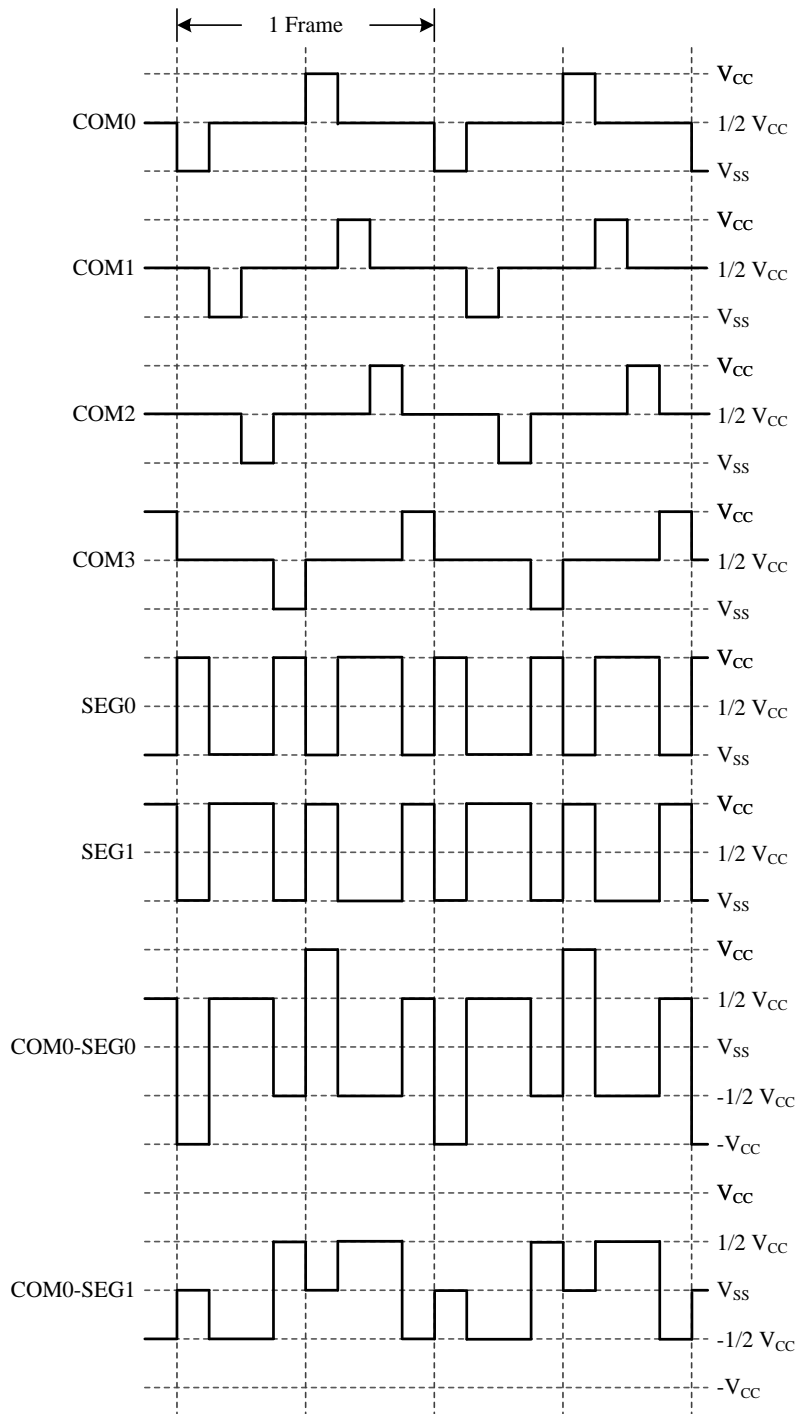
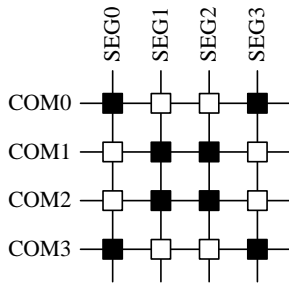

SFR AFh	Bit 7	Bit 6	Bit 5	Bit 4	Bit 3	Bit 2	Bit 1	Bit 0
<b>P1LOE</b>	–	–	–	–	P1LOE3	P1LOE2	P1LOE1	P1LOE0
R/W	–	–	–	–	R/W	R/W	R/W	R/W
Reset	–	–	–	–	0	0	0	0

92h.3 **P1LOE3:** LCD 1/2 bais Output

0: Disable

1: P15 as LCD 1/2 bais Output

92h.2 **P1LOE2:** LCD 1/2 bais Output

0: Disable

1: P14 as LCD 1/2 bais Output

92h.1 **P1LOE1:** LCD 1/2 bais Output

0: Disable

1: P13 as LCD 1/2 bais Output

92h.0 **P1LOE0:** LCD 1/2 bais Output

0: Disable

1: P12 as LCD 1/2 bais Output

### 14. Full Color LED Communication Format Waveform Generator

The input information of the waveform generator is stored in the 0xF200~0xF217 area of RAM (24 bytes in total). The waveform generator will serially output it to P3.4 according to the following encoding rules.

If data value is 0, then the output waveform will encode as shown in the figure below, Duty and Period can be adjusted by WGT0H and WGPRD.

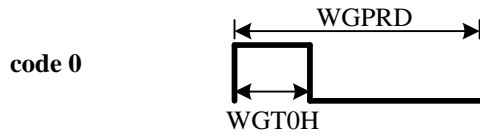

If data value is 1, then the output waveform will encode as shown in the figure below, Duty and Period can be adjusted by WGT1H and WGPRD.

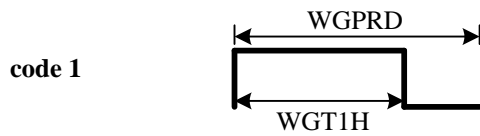

Use a long low level to separate different Transmit data, the length of the low level can be adjusted by WGRES.

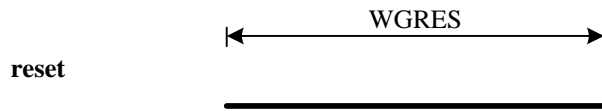

The length of the Transmit data can be adjusted by WGRES, ranging from 3 bytes to 24 bytes. The RGB value of one LED is 3 bytes, that is, it can support 1~8 LEDs.

WGDTS=3



P3.4 Serial output (WGDTS=3)

When user set WGMOD= 0 or 1, HW will send data code and reset code continuously, and it stop only if user clear WGEN bit manually; When user set WGMOD = 2, HW will send data code and reset code, then clear WGEN bit automatically by HW; When user set WGMOD = 3, HW only send data code, then clear WGEN bit automatically by HW.

N=1~8 select by WGDTS

WGMOD=0 or 1:

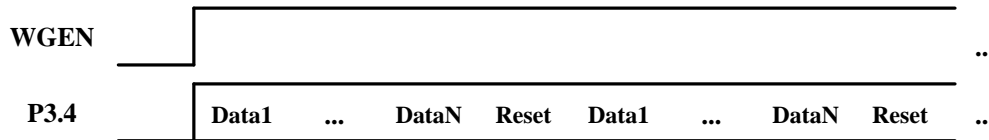

WGMOD=2:

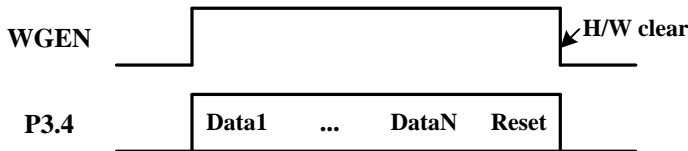

WGMOD=3:

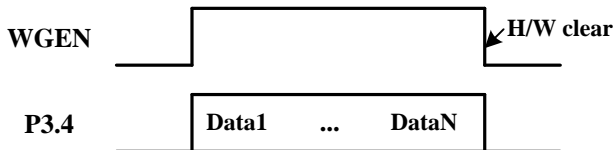

Three Mode Options

SFR 9Ah	Bit 7	Bit 6	Bit 5	Bit 4	Bit 3	Bit 2	Bit 1	Bit 0
WGCON	WGRES		WGMOD		WGTDS			WGEN
R/W	R/W		R/W		R/W			R/W
Reset	0	0	0	0	0	0	0	0

9Ah.7~6 **WGRES:** WG reset time select ( $T_{FRC} = 60.28 \text{ ns}$ )

- 0:  $7 * T_{FRC} = 54.0 \mu\text{s}$
- 1:  $11 * T_{FRC} = 84.9 \mu\text{s}$
- 2:  $21 * T_{FRC} = 162.0 \mu\text{s}$
- 3:  $37 * T_{FRC} = 285.5 \mu\text{s}$

9Ah.5~4 **WGMOD:** WG Mode select

- 0xb: Continue Mode. HW sends data code and reset code, repeating continuously, will not clear WGEN automatically.
- 10b: One Cycle Mode. HW will automatically clear WGEN after sending data code and reset code
- 11b: One Cycle Mode. HW will automatically clear WGEN after sending data code.

9Ah.3~1 **WGTDS:** WG Transmit data length select

- 0: 3 bytes (1 LED)
- 1: 6 bytes (2 LED)

- 2: 9 bytes (3 LED)
- 3: 12 bytes (4 LED)
- 4: 15 bytes (5 LED)
- 5: 18 bytes (6 LED)
- 6: 21 bytes (7 LED)
- 7: 24 bytes (8 LED)

9Ah.0 **WGEN:** WG enable and output to P3.4, H/W will automatically clear WGEN in One Cycle mode  
 0: WG disable, P3.4 as GPIO。 1: WG enable, P3.4 as WG output.

SFR 9Bh	Bit 7	Bit 6	Bit 5	Bit 4	Bit 3	Bit 2	Bit 1	Bit 0
<b>WGCON2</b>	WGPRD			WGT1H			WGT0H	
R/W	R/W			R/W			R/W	
Reset	0	0	0	0	0	0	0	0

9Bh.7~5 **WGPRD:** WG period of each bit select ( $T_{FRC} = 60.28 \text{ ns}$ )

- 0:  $17 * T_{FRC} = 1025 \text{ ns}$
- 1:  $18 * T_{FRC} = 1085 \text{ ns}$
- 2:  $19 * T_{FRC} = 1145 \text{ ns}$
- 3:  $20 * T_{FRC} = 1206 \text{ ns}$
- 4:  $21 * T_{FRC} = 1266 \text{ ns}$
- 5:  $22 * T_{FRC} = 1326 \text{ ns}$
- 6:  $23 * T_{FRC} = 1386 \text{ ns}$
- 7:  $24 * T_{FRC} = 1447 \text{ ns}$

9Bh.4~2 **WGT1H:** WG code 1 high level time select ( $T_{FRC} = 60.28 \text{ ns}$ )

- 0:  $10 * T_{FRC} = 603 \text{ ns}$
- 1:  $11 * T_{FRC} = 663 \text{ ns}$
- 2:  $12 * T_{FRC} = 723 \text{ ns}$
- 3:  $13 * T_{FRC} = 784 \text{ ns}$
- 4:  $14 * T_{FRC} = 844 \text{ ns}$
- 5:  $15 * T_{FRC} = 904 \text{ ns}$
- 6:  $16 * T_{FRC} = 964 \text{ ns}$
- 7:  $17 * T_{FRC} = 1025 \text{ ns}$

9Bh.1~0 **WGT0H:** WG code 0 high level time select ( $T_{FRC} = 60.28 \text{ ns}$ )

- 0:  $4 * T_{FRC} = 241 \text{ ns}$
- 1:  $5 * T_{FRC} = 301 \text{ ns}$
- 2:  $6 * T_{FRC} = 362 \text{ ns}$
- 3:  $7 * T_{FRC} = 422 \text{ ns}$

## 15. Operational Amplifier and Comparator

There is an Operational Amplifier (OPA) and a Comparator (CMP) in this device. The OPA can be set to normal mode or comparator mode by SOPM (9Fh.1~0). By setting the OPAPD=1 (9Fh.7), the OPA will enter power down mode. The SOPP (9Fh.6~5) register determined the OPA positive input channel (OPP) is P3.3, P1.4, P1.7, or VSS. The OPA negative input is VSS in normal mode, but it can be selected as VSS or VBG by SOTV (9Fh.4) in comparator mode. The 4-level OPA gain (1x/20x/50x/100x) used for normal mode is controlled by SOPG (9Fh.3~2).

The CMP built in a 7-bit DAC module, which output can be accessed to negative input port of the CMP. Reference Voltage of DAC can be selected as  $V_{CC}$  or  $V_{BG}$  by setting SVRF (9Ch.7).  $V_{BG}$  will be configured as 1.20V or 2.48V by setting VBGSEL (AEh.1~0). A suitable level of voltage can be selected for proper operation of user application by setting SVL (9Ch.6~0), which will change the resistance to transform the value of voltage. Setting the CMPPD=1 (9Dh.7) will let DAC and CMP enter power down mode. By configuring SCMPN (9Eh.7), negative port input source will be external pin input or DAC output. And positive port input source can be external pin input or OPA output (OPO) by defining OPOF (9Eh.3). The SCIN (9Eh.6~4) and SCIP (9Eh.2~0) register determine negative and positive port external input source respectively. Because the input module of the CMP is composed of PMOS, the input voltage range will be affected by  $V_{th}$  of the PMOS. Thus, the maximum input voltage of the CMP will be  $(V_{CC}-0.5)$  V. Meanwhile, the Comparator's hysteresis voltage is about 30mV. The Comparator original output (CMPOX) can be read by CMPOX (9Dh.6) bit. The Chip provides a de-bounce module to de-bounce the CMPOX signal, user can select de-bounce time by CMPDBS (9Dh.1~0). The de-bounce output signal can select invert or not by CMPINV (9Dh.4) to generate CMPO signal. The CMPO can be output to pin (P2.1) by set CMPOE (9Dh.5) and the P2MOD1 should be set to 10b. The CMPO is also a trigger source for the interrupt trigger module to generate interrupt flag CMPIF (95h.6). The trigger mode is selected by CMPTRIG (9Dh.3~2). When Comparator power down, the interrupt flag will still be produced. Therefore, it is necessary to clear the interrupt flag first after turning on the CMP module each time to prevent using the dummy flag.

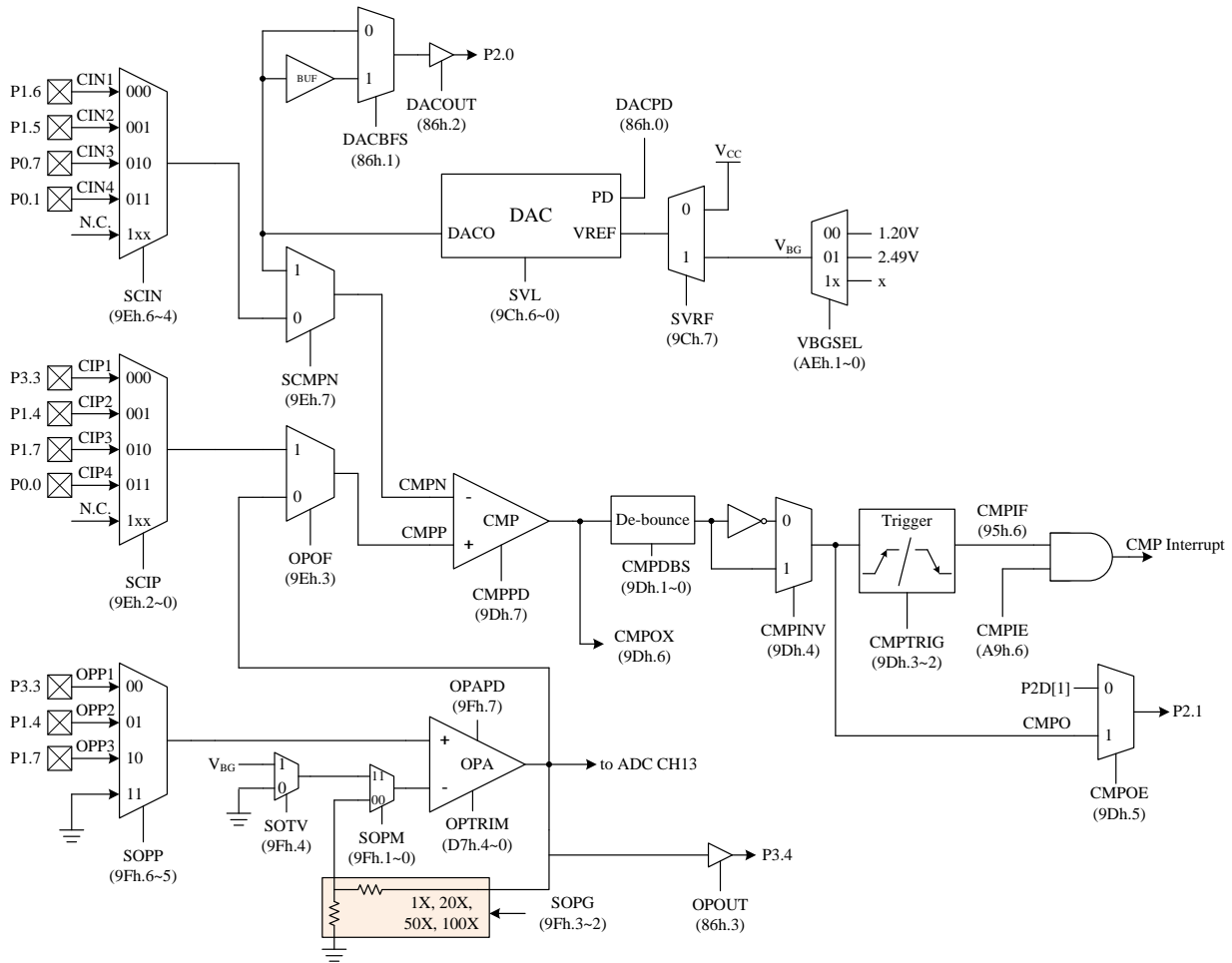

**Operational Amplifier and Comparator Structure**

A9h	Bit 7	Bit 6	Bit 5	Bit 4	Bit 3	Bit 2	Bit 1	Bit 0
INTIE1	PWMIE	CMPIE	LVDIE	SPI2CIE	ADTKIE	EX2	PXIE	TM3IE
R/W	R/W	R/W	R/W	R/W	R/W	R/W	R/W	R/W
Reset	0	0	0	0	0	0	0	0

A9h.6 **CMPIE**: Comparator interrupt enable  
 0: disable  
 1: enable

95h	Bit 7	Bit 6	Bit 5	Bit 4	Bit 3	Bit 2	Bit 1	Bit 0
INTFLG	LVDIF	CMPIF	TKIF	ADIF	-	IE2	PXIF	TF3
R/W	R/W	R/W	R/W	R/W	-	R/W	R/W	R/W
Reset	0	0	0	0	-	0	0	0

95h.6 **CMPIF**: Comparator interrupt flag  
 Set by H/W while CMPO match trigger condition. It is cleared automatically when the program performs the interrupt service routine. S/W writes BFh to INTFLG to clear this flag.

A Eh	Bit 7	Bit 6	Bit 5	Bit 4	Bit 3	Bit 2	Bit 1	Bit 0
CHSEL	ADCHS					ADCVREFS	VBGSEL	
R/W	R/W					R/W	R/W	
Reset	1	1	1	1	1	0	0	0

A Eh.1~0 **VBGSEL**: VBG voltage select.  
 00: 1.20V  
 01: 2.49V (need VCC>2.8V)  
 10: Reserved  
 11:Reserved

86h	Bit 7	Bit 6	Bit 5	Bit 4	Bit 3	Bit 2	Bit 1	Bit 0
DACON2	–	–	–	–	OPOUT	DACOUT	DACBFS	DACPD
R/W	–	–	–	–	R/W	R/W	R/W	R/W
Reset	–	–	–	–	0	0	0	1

86h.3 **OPOUT**: OPO output enable  
 0: P3.4 as normal IO  
 1:OPO output to P3.4  
 86h.2 **DACOUT**: DAC output enable  
 0:P2.0 as normal IO  
 1:DAC output to P2.0  
 86h.1 **DACBFS**: DAC Output Buffer select.  
 0: Output without Buffer  
 1: Output with Buffer  
 86h.0 **DACPD**: DAC Power Down.  
 0: DAC enable.  
 1: DAC disable.

9Ch	Bit 7	Bit 6	Bit 5	Bit 4	Bit 3	Bit 2	Bit 1	Bit 0
DACON	SVRF	SVL						
R/W	R/W	R/W						
Reset	0	0	0	0	0	0	0	0

9Ch.7 **SVRF**: DAC reference voltage select  
 0: VDDA  
 1: VBGO (define by VBGSEL AEh.1~0)  
 9Ch.6~0 **SVL**: Select DAC output voltage (reference source can be selected as VDDA or VBGO)  
 000\_0000: 0/128 \* reference source  
 000\_0001: 1/128 \* reference source  
 ...  
 111\_1101: 125/128 \* reference source  
 111\_1110: Reserved  
 111\_1111: Reserved

9Dh	Bit 7	Bit 6	Bit 5	Bit 4	Bit 3	Bit 2	Bit 1	Bit 0
CMPCON	CMPPD	CMPOX	CMPOE	CMPINV	CMPTRIG		CMPDBS	
R/W	R/W	R	R/W	R/W	R/W		R/W	
Reset	1	1	0	0	0	0	0	0

9Dh.7 **CMPPD**: Comparator & DAC power down enable control  
 0: disable Comparator & DAC power down

- 1: enable Comparator & DAC power down
- 9Dh.6 **CMPOX**: Comparator original output (CMPOX) status  
 0:  $V_{CMPP} < V_{CMPN}$   
 1:  $V_{CMPP} > V_{CMPN}$  or CMPPD =1
- 9Dh.5 **CMPOE**: Comparator output (CMPO) signal output to P2.1  
 0: disable  
 1: enable, P2MOD1 should be set to 10b
- 9Dh.4 **CMPINV**: Comparator de-bounce output invert select  
 0: no invert  
 1: invert
- 9Dh.3~2 **CMPTRIG**: Comparator interrupt trigger mode  
 00: Rising edge  
 01: Falling edge  
 10: Both edge  
 11: High level
- 9Dh.1~0 **CMPDBS**: Comparator original output (CMPOX) de-bounce time  
 00: none  
 01: 4 Fsys  
 10: 8 Fsys  
 11: 16 Fsys

9Eh	Bit 7	Bit 6	Bit 5	Bit 4	Bit 3	Bit 2	Bit 1	Bit 0
CMPPNS	SCMPN	SCIN			OPOF	SCIP		
R/W	R/W	R/W			R/W	R/W		
Reset	1	1	1	1	0	1	1	1

- 9Eh.7 **SCMPN**: Comparator CMPN source select  
 0: Comparator CMPN source is external input (CINx)  
 1: Comparator CMPN source is DAC output
- 9Eh.6~4 **SCIN**: Comparator CMPN external input select  
 000: Comparator CMPN external input is CIN1 (P1.6)  
 001: Comparator CMPN external input is CIN2 (P1.5)  
 010: Comparator CMPN external input is CIN3 (P0.7)  
 011: Comparator CMPN external input is CIN4 (P0.1)  
 1xx: No connect
- 9Eh.3 **OPOF**: OPA output (OPO) connect to Comparator CMPP  
 0: Comparator CMPP source is OPA output (OPO)  
 1: Comparator CMPP source is external input (CIPx)
- 9Eh.2~0 **SCIP**: Comparator CMPP external input select  
 000: Comparator CMPP external input is CIP1 (PA1)  
 001: Comparator CMPP external input is CIP2 (PA2)  
 010: Comparator CMPP external input is CIP3 (PB6)  
 011: Comparator CMPP external input is CIP4 (PD1)  
 1xx: No connect

9Fh	Bit 7	Bit 6	Bit 5	Bit 4	Bit 3	Bit 2	Bit 1	Bit 0
OPCON	OPAPD	SOPP		SOTV	SOPG		SOPM	
R/W	R/W	R/W		R/W	R/W		R/W	
Reset	1	1	1	0	1	1	0	0

- 9Fh.7 **OPAPD**: OPA power down enable control  
 0: disable OPA power down  
 1: enable OPA power down
- 9Fh.6~5 **SOPP**: select OPP input source  
 00: OPP input source is P3.3



- 01: OPP input source is P1.4
- 10: OPP input source is P1.7
- 11: OPP input source is VSS
- 9Fh.4 **SOTV:** OPN input voltage selection in Comparator mode
  - 0:  $V_{SS}$
  - 1:  $V_{BG}$  (voltage level is selected by VBGSEL)
- 9Fh.3~2 **SOPG:** select OPA gain
  - 00: 1X
  - 01: 20X
  - 10: 50X
  - 11: 100X
- 9Fh.1~0 **SOPM:** select OPA operating mode
  - 00: Normal Mode
  - 01: Reserved
  - 10: Reserved
  - 11: Comparator Mode

D7h	Bit 7	Bit 6	Bit 5	Bit 4	Bit 3	Bit 2	Bit 1	Bit 0
CFGOP	–	–	–	OPTRIM				
R/W	–	–	–	R/W				
Reset	–	–	–	-	-	-	-	-

- D7h.4~0 **OPTRIM:** OP trimming value.
  - 00000: minimum
  - 11111: maximum

## 16. Serial Peripheral Interface (SPI)

The SPI module is capable of full-duplex, synchronous, serial communication between the chip and peripheral devices. The peripheral devices can be other MCUs, A/D converter, sensors, or Flash memory, etc. The SPI runs at a baud rate up to the system clock divided by two. Firmware can read the status flags, or the operation can be interrupt driven.

The features of the SPI module include:

- Master or Slave mode operation
- 3-wire mode operation
- Full-duplex operation
- Programmable transmit bit rate
- Single buffer receive
- Serial clock phase and polarity options
- MSB-first or LSB-first shifting selectable

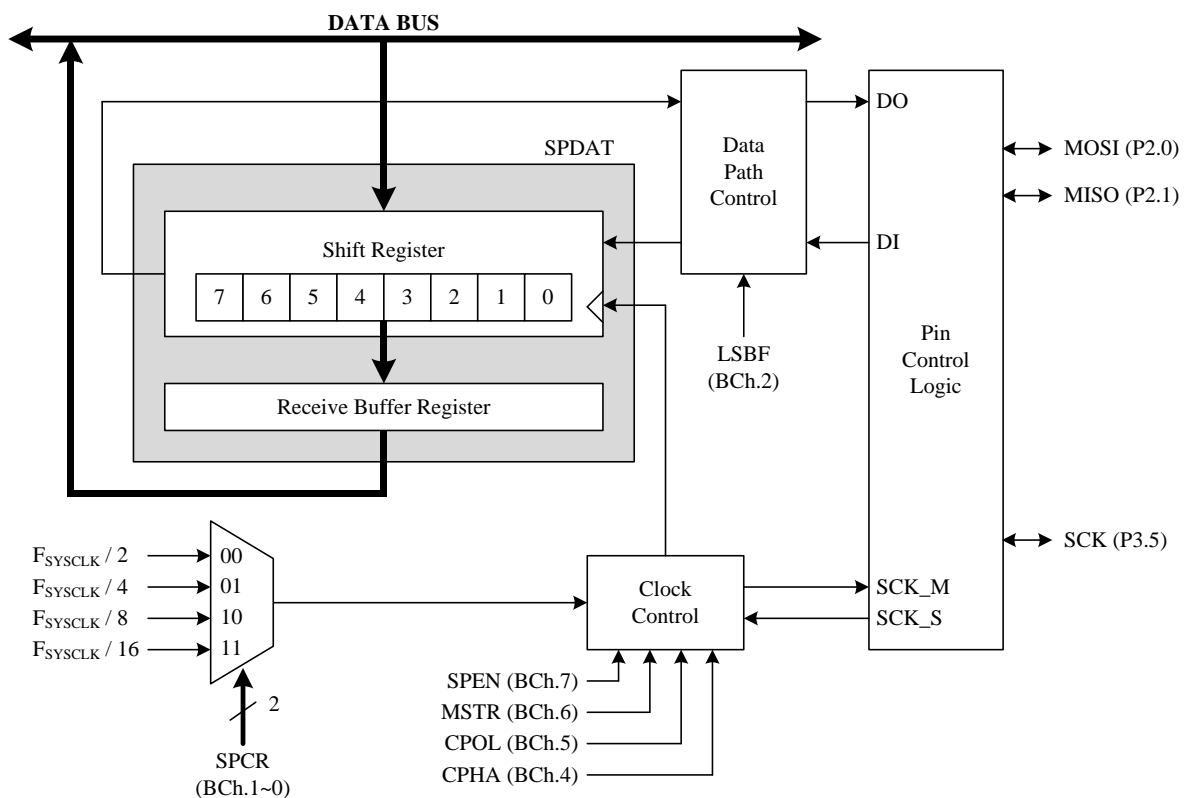

The MOSI (P2.0) signal is an output when SPI is operating in Master mode and an input when SPI is operating in Slave mode. The MISO (P2.1) signal is an input when SPI is operating in Master mode and an output when SPI is operating in Slave mode. Data is transferred MSB or LSB first by setting the LSBF bit. The SCK (P3.5) signal is an output from a Master device and an input to Slave devices. It is used to synchronize the data on the MOSI and MISO lines of Master and Slave. SPI generates the signal with eight programmable clock rates in Master mode.

### Master Mode

The SPI operates in Master mode by setting the MSTR bit in the SPCON. To start transmit, writing a data to the SPDAT. If SPBSY=0, the data will be transferred to the shift register and starts shift out on the MOSI line. The data of the Slave shift in from the MISO line at the same time. When the SPIF bit becomes set at the end of transfer, the receive data is written to receiver buffer and the RCVBF bit in the SPSTA is set. To prevent an overrun condition, software must read the SPDAT before next byte enters the shift register. The SPBSY bit will be set when writing a data to SPDAT to start transmit, and be cleared at the end of the eighth SCK period in Master mode.

### Slave Mode

The SPI operates in Slave mode by clearing the MSTR bit in the SPCON. The transmission will start when the SPEN bit in the SPCON is set. The data from a Master will shift into the shift register through the MOSI line, and shift out from the shift register on the MISO line. When a byte enters the shift register, the data will be transferred to receiver buffer if RCVBF=0. If RCVBF=1, the newer received data will not be transferred to receiver buffer and the RCVOVF bit is set. After a byte enters the shift register, the SPIF and RCVBF bits are set. To prevent an overrun condition, software must read the SPDAT or write 0 to RCVBF before next byte enters the shift register. The maximum SCK frequency allowed in Slave mode is  $F_{\text{SYSCLK}}/4$ .

### Serial Clock

The SPI has four clock types by setting the CPOL and CPHA bits in the SPCON register. The CPOL bit defines the level of the SCK in SPI idle state. The level of the SCK in idle state is low when CPOL=0, and is high when CPOL=1. The CPHA bit defines the edges used to sample and shift data. The SPI sample data on the first edge of SCK period and shift data on the second edge of SCK period when CPHA=0. The SPI sample data on the second edge of SCK period and shift data on first edge of SCK period when CPHA=1. Figures below show the detail timing in Master and Slave modes. Both Master and Slave devices must be configured to use the same clock type before the SPEN bit is set. The SPCR controls the Master mode serial clock frequency. This register is ignored when operating in Slave mode. The SPI clock can select System clock divided by 2, 4, 8, or 16 in Master mode.

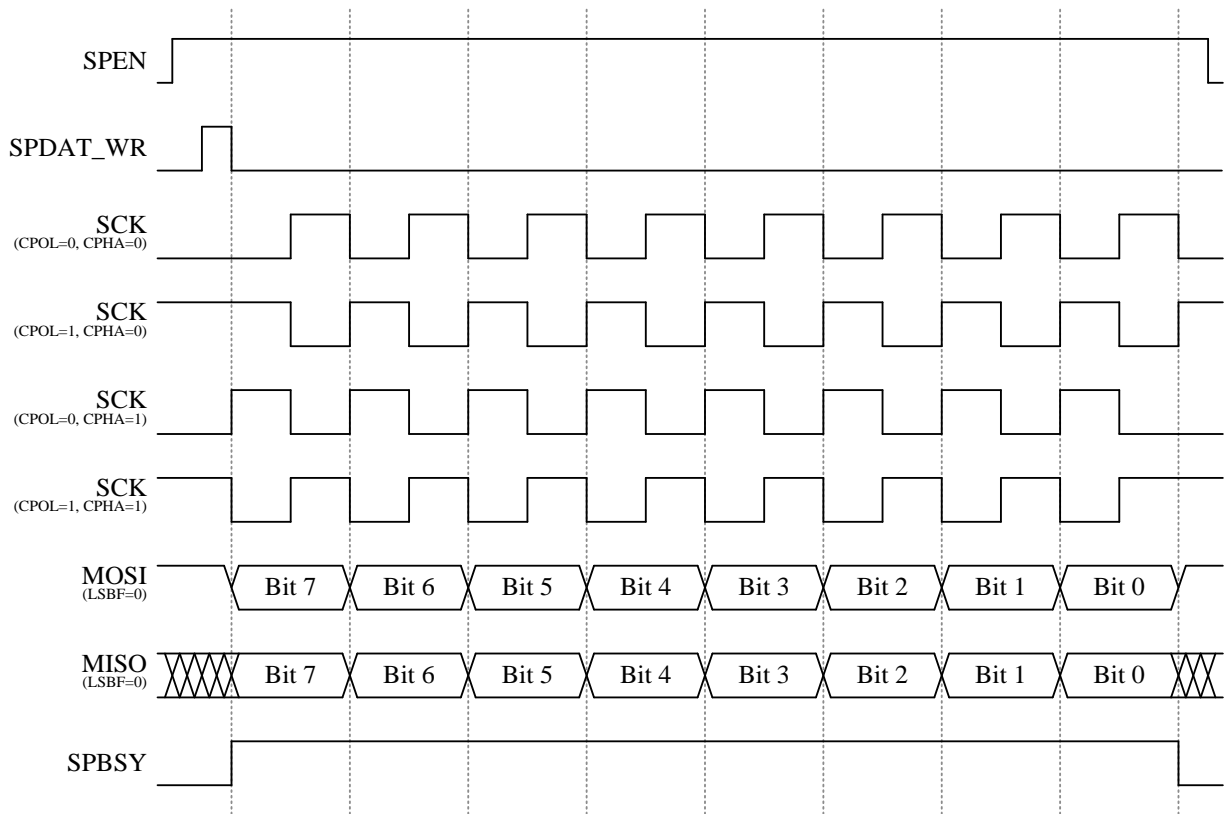

Master Mode Timing

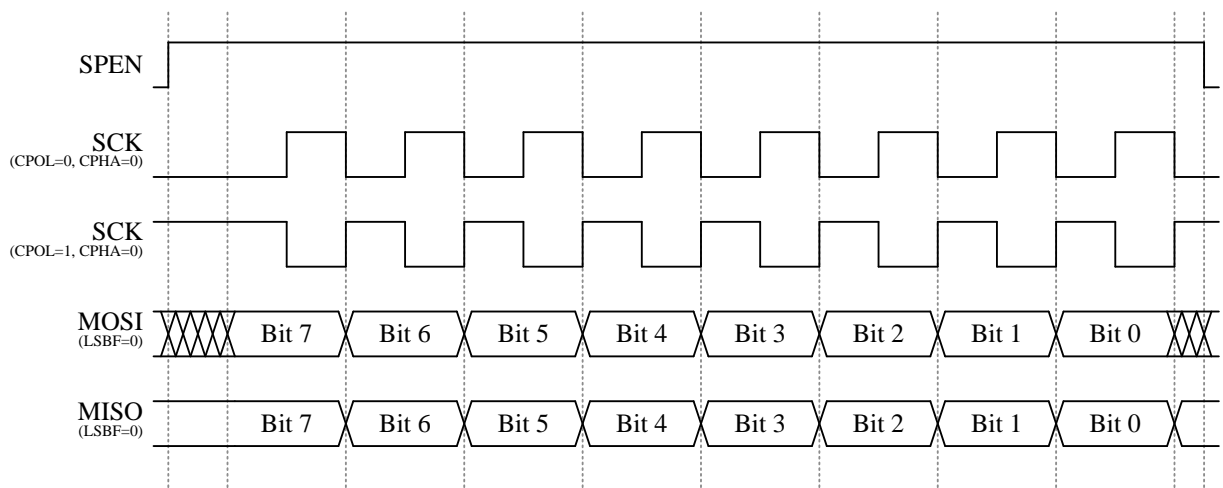

Slave Mode Timing (CPHA=0)

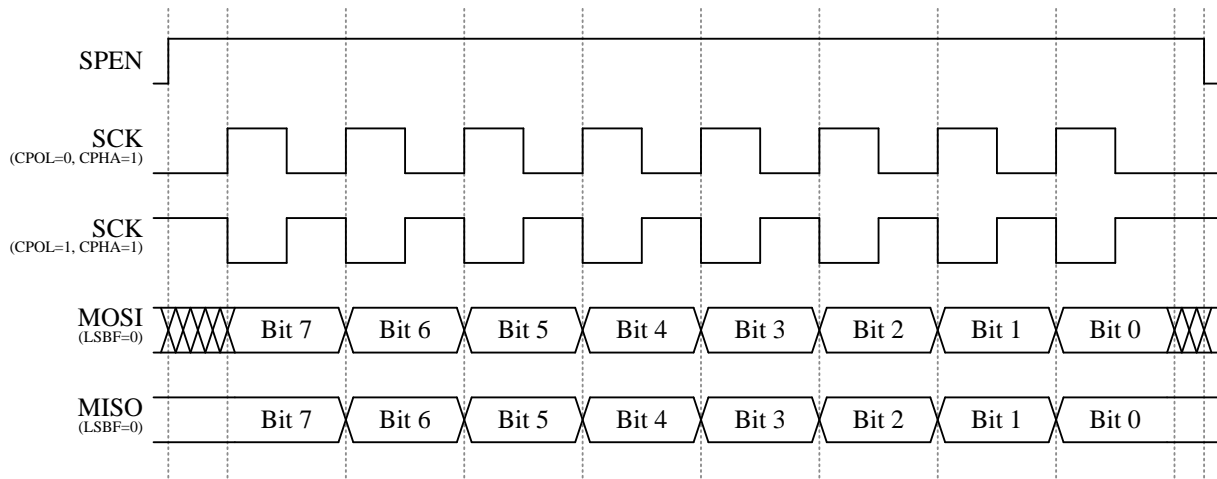
**Slave Mode Timing (CPHA=1)**

In both Master and Slave modes, the SPIF interrupt flag is set by H/W at the end of a data transfer. If write data to SPDAT when SPBSY=1, the WCOL interrupt flag will be set by H/W. When this occurs, the data write to SPDAT will be ignored, and shift register will not be written.

SFR BCh	Bit 7	Bit 6	Bit 5	Bit 4	Bit 3	Bit 2	Bit 1	Bit 0
<b>SPCON</b>	SPEN	MSTR	CPOL	CPHA	-	LSBF	SPCR	
R/W	R/W	R/W	R/W	R/W	-	R/W	R/W	
Reset	0	0	0	0	-	0	0	0

- BCh.7 **SPEN**: SPI enable  
0: SPI disable  
1: SPI enable
- BCh.6 **MSTR**: Master mode enable  
0: Slave mode  
1: Master mode
- BCh.5 **CPOL**: SPI clock polarity  
0: SCK is low in idle state  
1: SCK is high in idle state
- BCh.4 **CPHA**: SPI clock phase  
0: Data sample on first edge of SCK period  
1: Data sample on second edge of SCK period
- BCh.2 **LSBF**: LSB first  
0: MSB first  
1: LSB first
- BCh.1~0 **SPCR**: SPI clock rate  
00:  $F_{SYSCLK}/2$   
01:  $F_{SYSCLK}/4$   
10:  $F_{SYSCLK}/8$   
11:  $F_{SYSCLK}/16$

SFR BDh	Bit 7	Bit 6	Bit 5	Bit 4	Bit 3	Bit 2	Bit 1	Bit 0
<b>SPSTA</b>	SPIF	WCOL	-	RCVOVF	RCVBF	SPBSY	-	-
R/W	R/W	R/W	-	R/W	R/W	R	-	-
Reset	0	0	-	0	0	0	-	-

- BDh.7 **SPIF**: SPI interrupt flag  
This is set by H/W at the end of a data transfer. Cleared by H/W when an interrupt is vectored into. Writing 0 to this bit will clear this flag.
- BDh.6 **WCOL**: Write collision interrupt flag  
Set by H/W if write data to SPDAT when SPBSY is set. Write 0 to this bit or rewrite data to SPDAT





- when SPBSY is cleared will clear this flag.
- BDh.4 **RCVOVF**: Received buffer overrun flag  
Set by H/W at the end of a data transfer and RCVBF is set. Write 0 to this bit or read SPDAT register will clear this flag.
- BDh.3 **RCVBF**: Receive buffer full flag  
Set by H/W at the end of a data transfer. Write 0 to this bit or read SPDAT register will clear this flag.
- BDh.2 **SPBSY**: SPI busy flag  
Set by H/W when a SPI transfer is in progress.

SFR BEh	Bit 7	Bit 6	Bit 5	Bit 4	Bit 3	Bit 2	Bit 1	Bit 0
<b>SPDAT</b>	SPDAT							
R/W	R/W							
Reset	0	0	0	0	0	0	0	0

- BEh.7~0 **SPDAT**: SPI transmit and receive data  
The SPDAT register is used to transmit and receive data. Writing data to SPDAT place the data into shift register and start a transfer when in master mode. Reading SPDAT returns the contents of the receive buffer.

### 17. Cyclic Redundancy Check (CRC)

The chip supports an integrated 16-bit Cyclic Redundancy Check function. The Cyclic Redundancy Check (CRC) calculation unit is an error detection technique test algorithm and uses to verify data transmission or storage data correctness. The CRC calculation takes a 8-bit data stream or a block of data as input and generates a 16-bit output remainder. The data stream is calculated by the same generator polynomial.

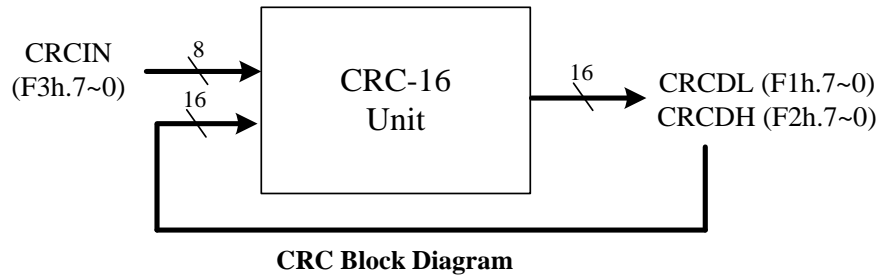

The CRC generator provides the 16-bit CRC result calculation based on the CRC-16-IBM polynomial. In this CRC generator, there are only one polynomial available for the numeric values calculation. It can't support the 16-bit CRC calculations based on any other polynomials. Each write operation to the CRCIN register creates a combination of the previous CRC value stored in the CRCDH and CRCDL registers. It will take one MCU instruction cycle to calculate.

**CRC-16-IBM (Modbus) Polynomial representation:  $X^{16} + X^{15} + X^2 + 1$**

SFR F1h	Bit 7	Bit 6	Bit 5	Bit 4	Bit 3	Bit 2	Bit 1	Bit 0
<b>CRCDL</b>	CRCDL							
R/W	R/W							
Reset	1	1	1	1	1	1	1	1

F1h.7~0 **CRCDL:** 16-bit CRC checksum data bit 7~0

SFR F2h	Bit 7	Bit 6	Bit 5	Bit 4	Bit 3	Bit 2	Bit 1	Bit 0
<b>CRCDH</b>	CRCDH							
R/W	R/W							
Reset	1	1	1	1	1	1	1	1

F2h.7~0 **CRCDL:** 16-bit CRC checksum data bit 15~8

SFR F3h	Bit 7	Bit 6	Bit 5	Bit 4	Bit 3	Bit 2	Bit 1	Bit 0
<b>CRCIN</b>	CRCIN							
W	W							
Reset	-	-	-	-	-	-	-	-

F3h.7~0 **CRCIN:** CRC input data register

### 18. Multiplier and Divider

The chip provide multiplier and divider have the following functions. The 8 bit operation is fully compatible with industry standard 8051.

- 8 bits  $\times$  8 bits = 16 bit (standard 8051)
- 8 bits  $\div$  8 bits = 8 bits, 8 bits remainder (standard 8051)
- 16 bits  $\times$  16 bits = 32 bit
- 16 bits  $\div$  16 bits = 16 bits, 16 bits remainder
- 32 bits  $\div$  16 bits = 32 bits, 16 bits remainder

No matter 8bit / 16bit / 32bit operation, it's easy to execute by MUL AB and DIV AB instruction. There is extra SFR EXA/EXA2/EXA3/EXB for 16bit / 32bit multiply and divide operation.

For 8 bit multiplier/divider operation, be sure SFR bit muldiv16=0 and div32=0.

For 16 bit multiplier operation, multiplicand, multiplier and product as follows. 16 bit multiplier takes 16 System clock cycles to execute.

Condition	SFR bit muldiv16=1 and div32=0			
Multiplication	Byte3	Byte2	Byte1	Byte0
Multiplicand	-	-	EXA	A
Multiplier	-	-	EXB	B
Product	EXB	B	A	EXA
OV	Product (EXB or B) !=0			-

For 16 bit divider operation, dividend, divisor, quotient, remainder read as follows. 16 bit divider takes 16 System clock cycles to execute.

Condition	SFR bit muldiv16=1 and div32=0			
Division	Byte3	Byte2	Byte1	Byte0
Dividend	-	-	EXA	A
Divisor	-	-	EXB	B
Quotient	-	-	A	EXA
Remainder	-	-	B	EXB
OV	Divisor EXB = B =0			

For 32 bits  $\div$  16 bits operation, dividend, divisor, quotient, remainder read as follows. 32 bit divider takes 32 System clock cycles to execute.

Condition	SFR bit muldiv16=1 and div32=1			
Division	Byte3	Byte2	Byte1	Byte0
Dividend	EXA3	EXA2	EXA	A
Divisor	-	-	EXB	B
Quotient	A	EXA	EXA2	EXA3
Remainder	-	-	B	EXB
OV	Divisor EXB=B =0			

SFR CEh	Bit 7	Bit 6	Bit 5	Bit 4	Bit 3	Bit 2	Bit 1	Bit 0
<b>EXA2</b>	EXA2							
R/W	R/W	R/W	R/W	R/W	R/W	R/W	R/W	R/W
Reset	0	0	0	0	0	0	0	0

CEh.7~0 **EXA2**: Expansion accumulator 2

SFR CFh	Bit 7	Bit 6	Bit 5	Bit 4	Bit 3	Bit 2	Bit 1	Bit 0
<b>EXA3</b>	EXA3							
R/W	R/W	R/W	R/W	R/W	R/W	R/W	R/W	R/W
Reset	0	0	0	0	0	0	0	0

CFh.7~0 **EXA3**: Expansion accumulator 3

SFR E6h	Bit 7	Bit 6	Bit 5	Bit 4	Bit 3	Bit 2	Bit 1	Bit 0
<b>EXA</b>	EXA							
R/W	R/W	R/W	R/W	R/W	R/W	R/W	R/W	R/W
Reset	0	0	0	0	0	0	0	0

E6h.7~0 **EXA**: Expansion accumulator

SFR E7h	Bit 7	Bit 6	Bit 5	Bit 4	Bit 3	Bit 2	Bit 1	Bit 0
<b>EXB</b>	EXB							
R/W	R/W	R/W	R/W	R/W	R/W	R/W	R/W	R/W
Reset	0	0	0	0	0	0	0	0

E7h.7~0 **EXB**: Expansion B register

SFR F7h	Bit 7	Bit 6	Bit 5	Bit 4	Bit 3	Bit 2	Bit 1	Bit 0
<b>AUX2</b>	WDTE		PWRSVAV	VBGOUT	DIV32	IAPTE		MULDIV16
R/W	R/W	R/W	R/W	R/W	R/W	R/W		R/W
Reset	0	0	0	0	0	0	0	0

F7h.3 **DIV32**:

only active when MULDVI16 = 1

0: instruction DIV as 16/16 bit division operation

1: instruction DIV as 32/16 bit division operation

F7h.0 **MULDIV16**:

0: instruction MUL/DIV as 8\*8, 8/8 operation

1: instruction MUL/DIV as 16\*16, 16/16 or 32/16 operation

ARITHMETIC				
Mnemonic	Description	byte	cycle	opcode
MUL AB	Multiply A by B	1	8/16	A4
DIV AB	Divide A by B	1	8/16/32	84

### 19. Master I<sup>2</sup>C Interface

#### Master I<sup>2</sup>C interface Transmitter mode:

At the beginning write slave address and direction bit to MIDAT and set MISTART. After the START condition (MISTART), the 7 bits slave address and one bit direction bit are sent. When MIIF convert to 1, address and direction bit transmission was complete. After sending the address and direction bit, user should clear MIIF and write MIDAT to start first data transmission. When MIIF convert to 1, data transfer to slave was complete. User can write MIDAT again to transfer next data to slave. Set MISTOP to finish transmitter mode.

MISTART must remain at 1 for the next transfer. After final data transmit/receive, set MISTOP to finish transmit/receive protocol. MISTART should remain 0 longer than a SCL clock before starting the next Master I<sup>2</sup>C protocol. SCL clock can be adjusted via MICR.

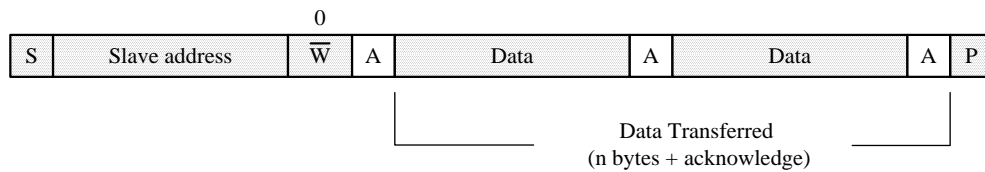

A master-transmitter addressing a slave receiver with a 7-bit address.  
The transfer direction is not changed

- |                                     |                      |                    |
|-------------------------------------|----------------------|--------------------|
| <input checked="" type="checkbox"/> | From master to slave | A: acknowledge     |
| <input type="checkbox"/>            | From slave to master | S: start condition |
|                                     |                      | P: stop condition  |

#### Master I<sup>2</sup>C Transmit flow:

- (1) Write slave address and direction bit to MIDAT
- (2) Clear MISTOP and set MISTART to start I<sup>2</sup>C transmission
- (3) Wait until MIIF converter to 1 (interrupt will be issued according to the user's request) and Clear MIIF
- (4) Write data to MIDAT to start next transfer (MISTART must remain at 1)
- (5) Wait until MIIF converter to 1 (interrupt will be issued according to the user's request) and Clear MIIF, Loop (3) ~ (4) for next transfer.
- (6) Clear MISTART and set MISTOP to stop the I<sup>2</sup>C transfer

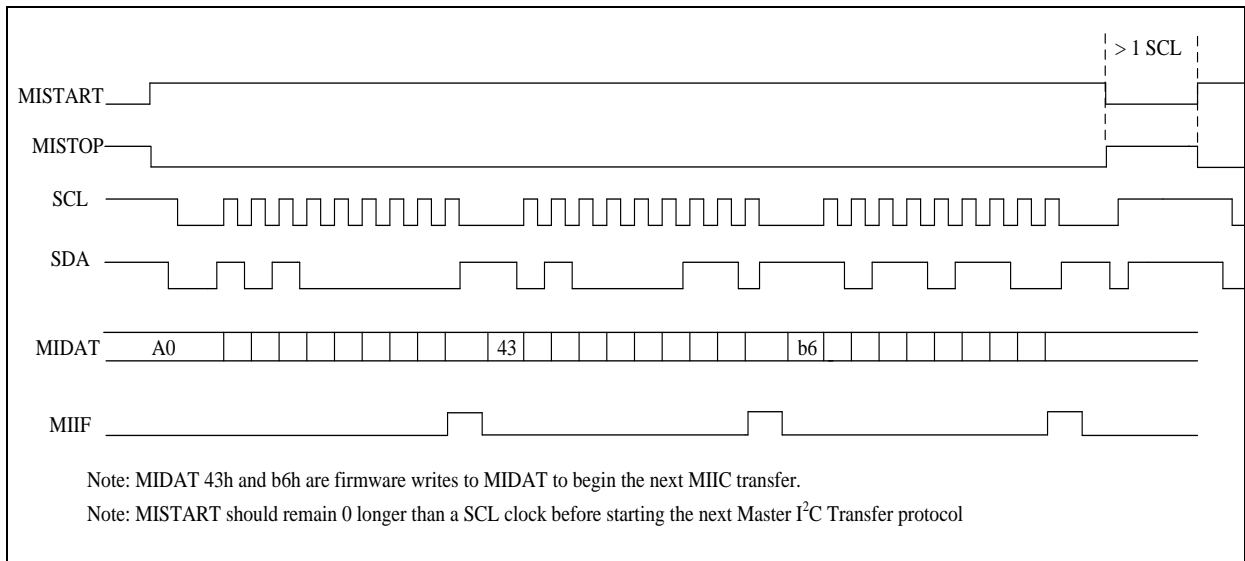

**Master Transmit Timing**

*Note: MISTART should remain 0 longer than a SCL period before starting the next Master I<sup>2</sup>C protocol.*

**Master I<sup>2</sup>C interface Receive mode:**

At the beginning write slave address and direction bit to MIDAT and set MISTART. After the START condition (MISTART), the 7 bits slave address and one bit direction bit are sent. When MIIF convert to 1, address and direction bit transmission was complete. After sending the address and direction bit, user should clear MIIF and read MIDAT to start first receive data (The first reading of MIDAT does not represent the data returned by the slave). When MIIF convert to 1, data receive from slave was complete. User can read MIDAT to get data from slave, and start next receive. Set MISTOP to finish receive mode.

MISTART must remain at 1 for the next transfer. After final data transmit/receive, set MISTOP to finish transmit/receive protocol. MISTART should remain 0 longer than a SCL clock before starting the next Master I<sup>2</sup>C protocol. SCL clock can be adjusted via MICR.

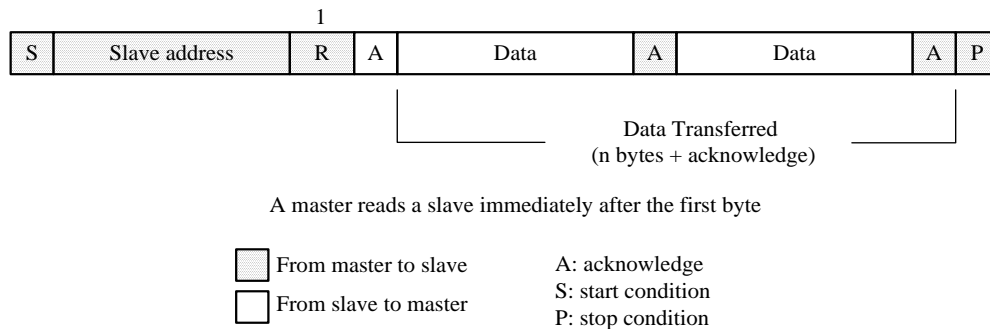

**Master I<sup>2</sup>C Receive flow:**

- (1) Write slave address and direction bit to MIDAT
- (2) Clear MISTOP and set MISTART to start I<sup>2</sup>C transmission
- (3) Wait until MIIF converter to 1 (interrupt will be issued according to the user's request)
- (4) Clear MIIF
- (5) Read data from MIDAT to start first receive data  
(The first reading of MIDAT does not represent the data returned by the slave)
- (6) Wait until MIIF converter to 1
- (7) Clear MIIF
- (8) Read slave data from MIDAT and receive next data
- (9) Loop (6) ~ (8)
- (10) Set MISTOP to stop the I<sup>2</sup>C transfer

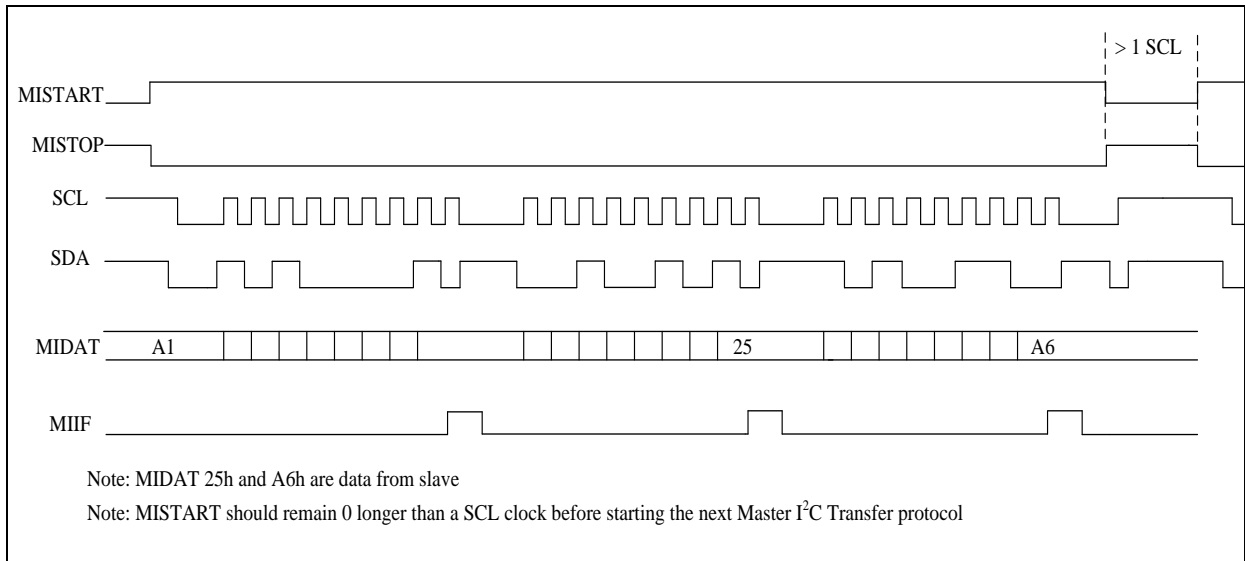

**Master Receive Timing**



SFR A9h	Bit 7	Bit 6	Bit 5	Bit 4	Bit 3	Bit 2	Bit 1	Bit 0
<b>INTE1</b>	PWMIE	CMPIE	LVDIE	SPI2CE	ADTKIE	EX2	PXIE	TM3IE
R/W	R/W	R/W	R/W	R/W	R/W	R/W	R/W	R/W
Reset	0	0	0	0	0	0	0	0

A9h.4 **SPI2CE: I<sup>2</sup>C interrupt enable**  
 0: Disable SPI/I<sup>2</sup>C interrupt 1: Enable SPI/I<sup>2</sup>C interrupt

SFR B7h	Bit 7	Bit 6	Bit 5	Bit 4	Bit 3	Bit 2	Bit 1	Bit 0
<b>PWMOE2</b>	MSDASEL	MSCLSEL	PWM6OE2	PWM6OE1	PWM6OE0	PWM5OE2	PWM5OE1	PWM5OE0
R/W	R/W	R/W	R/W	R/W	R/W	R/W	R/W	R/W
Reset	0	0	0	0	0	0	0	0

B7h.7 **MSDASEL: Master I<sup>2</sup>C SDA select**  
 0: P3.5 as Master I<sup>2</sup>C SDA  
 1: P1.6 as Master I<sup>2</sup>C SDA

B7h.6 **MSCLSEL: Master I<sup>2</sup>C SCL select**  
 0: P1.3 as Master I<sup>2</sup>C SCL  
 1: P0.2 as Master I<sup>2</sup>C SCL

SFR E1h	Bit 7	Bit 6	Bit 5	Bit 4	Bit 3	Bit 2	Bit 1	Bit 0
<b>MICON</b>	MIEN	MIACKO	MIIF	MIACKI	MISTART	MISTOP	MICR	
R/W	R/W	R/W	R/W	R	R/W	R/W	R/W	R/W
Reset	0	0	0	0	0	1	0	0

E1h.7 **MIEN: Master I<sup>2</sup>C enable**  
 0: disable 1: enable

E1h.6 **MIACKO: When Master I<sup>2</sup>C receive data, send acknowledge to I<sup>2</sup>C Bus**  
 0: ACK to slave device 1: NACK to slave device

E1h.5 **MIIF: Master I<sup>2</sup>C Interrupt flag**  
 0: write 0 to clear it  
 1: Master I<sup>2</sup>C transfer one byte complete

E1h.4 **MIACKI: When Master I<sup>2</sup>C transfer, acknowledgement form I<sup>2</sup>C bus (read only)**  
 0: ACK received 1: NACK received

E1h.3 **MISTART: Master I<sup>2</sup>C Start bit**  
 1: start I<sup>2</sup>C bus transfer

E1h.2 **MISTOP: Master I<sup>2</sup>C Stop bit**  
 1: send STOP signal to stop I<sup>2</sup>C bus

E1h.1~0 **MICR: Master I<sup>2</sup>C (SCL) clock frequency selection**  
 00: Fsys/4 (ex. If Fsys=16MHz, I<sup>2</sup>C clock is 4M Hz)  
 01: Fsys/16 (ex. If Fsys=16MHz, I<sup>2</sup>C clock is 1M Hz)  
 10: Fsys/64 (ex. If Fsys=16MHz, I<sup>2</sup>C clock is 250K Hz)  
 11: Fsys/256 (ex. If Fsys=16MHz, I<sup>2</sup>C clock is 62.5K Hz)

SFR E2h	Bit 7	Bit 6	Bit 5	Bit 4	Bit 3	Bit 2	Bit 1	Bit 0
<b>MIDAT</b>	MIDAT							
R/W	R/W	R/W	R/W	R/W	R/W	R/W	R/W	R/W
Reset	0	0	0	0	0	0	0	0

E2h.7~0 **MIDAT: Master I<sup>2</sup>C data shift register**  
 (W):After Start and before Stop condition, write this register will resume transmission to I<sup>2</sup>C bus  
 (R): After Start and before Stop condition, read this register will resume receiving from I<sup>2</sup>C bus

## 20. In Circuit Emulation (ICE) Mode

This device can support the In Circuit Emulation Mode. To use the ICE Mode, user just needs to connect P3.0 and P3.1 pin to the tenx proprietary EV Module. The benefit is that user can emulate the whole system without changing the on board target device. But there are some limits for the ICE mode as below.

1. The device must be un-protect.
2. The device's P3.0 and P3.1 pins must work in input Mode (P3MOD0 = 0/1 and P3MOD1=0/1).
3. The Program Memory's addressing space 2D00h~2FFFh and 0033h~003Ah are occupied by tenx EV module. So user Program cannot access these spaces.
4. The T-Link communication pin's function cannot be emulated.
5. The P3.0 and P3.1 pin's can be replaced by P2.0 and P2.1. (Only emulation can be replaced, mass production writer only supports P3.0/P3.1)
6. The VDD level is controlled by T-Link module.

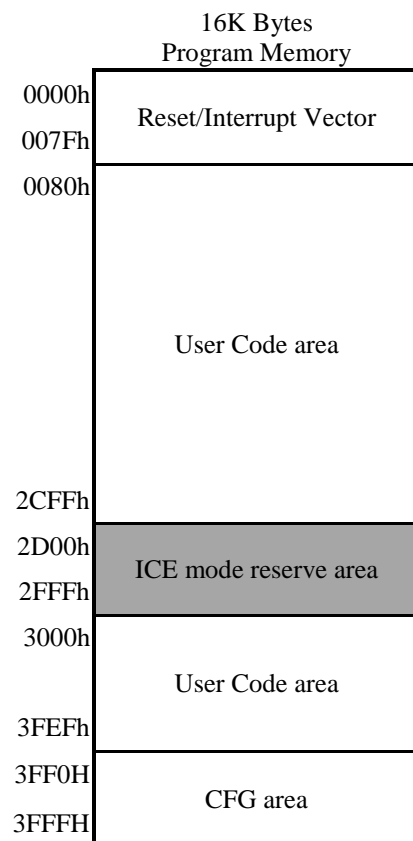
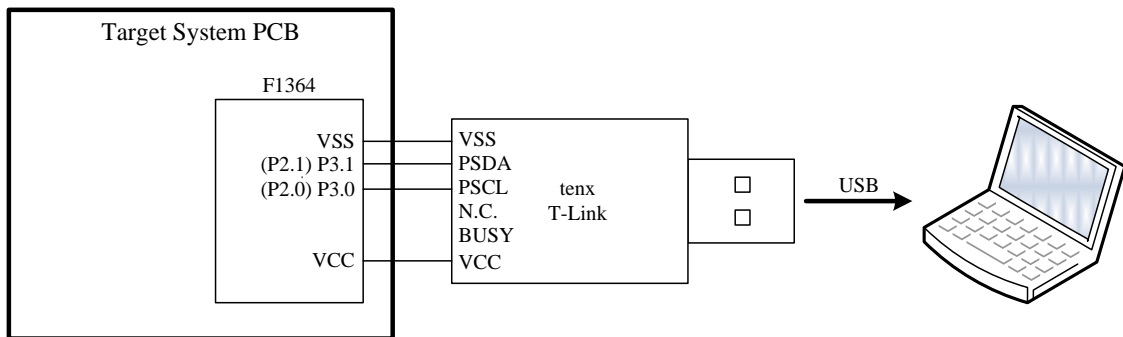

ICE tool settings introduction

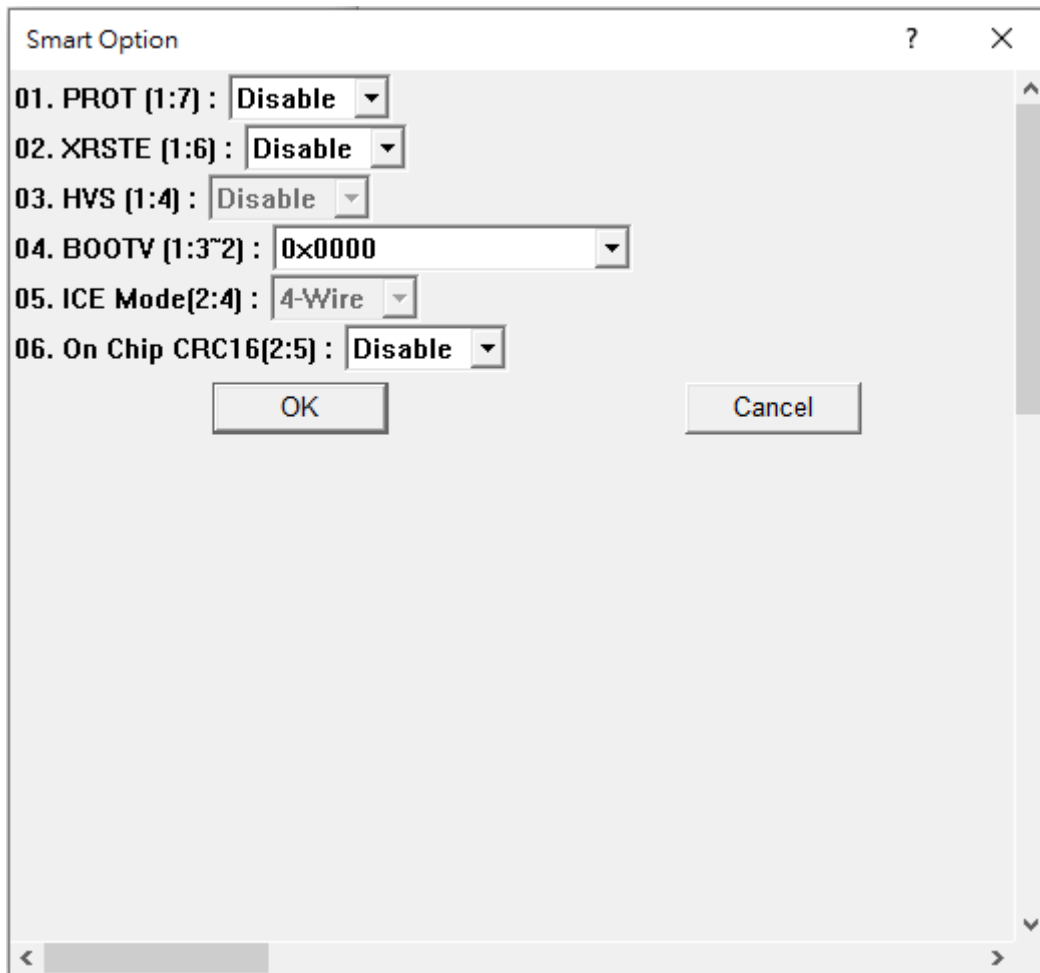

No.	Item	Description
01	PROT	<b>Enable:</b> Flash code is protect, Writer cannot access the ROM code <b>Disable:</b> Flash code is not protect, Writer can access the ROM code (default)
02	XRSTE	<b>Enable:</b> P3.7 is external reset pin <b>Disable:</b> P3.7 is normal I/O pin (default)
03	HVS	Reserved
04	BOOTV	Reset Vector after POR 00: Reset Vector = 0x3800, BOOT Area Size = 2K 01: Reset Vector = 0x3000, BOOT Area Size = 4K 1x: Reset Vector = 0x0000, no BOOT Area
05	ICE Mode	Reserved
06	On Chip CRC16	<b>Enable:</b> On chip CRC-16 function enable <b>Disable:</b> On chip CRC-16 function disable (default)

**SFR & CFGW MAP**

Adr	RST	NAME	Bit 7	Bit 6	Bit 5	Bit 4	Bit 3	Bit 2	Bit 1	Bit 0	
80h	1111-1111	<b>P0</b>	P0.7	P0.6	P0.5	P0.4	P0.3	P0.2	P0.1	P0.0	
81h	0000-0111	<b>SP</b>	SP								
82h	0000-0000	<b>DPL</b>	DPL								
83h	0000-0000	<b>DPH</b>	DPH								
84h	x00x-xx00	<b>INTE2</b>	-	PWM1IE	PWM0IE	-	-	-	TKBIE	TKAIE	
85h	x00x-xx00	<b>INTFLG2</b>	-	PWM1IF	PWM0IF	-	-	-	TKBIF	TKAIF	
86h	xxxx-0001	<b>DACON2</b>	-	-	-	-	OPOUT	DACOUT	DACBFS	DACPD	
87h	0xxx-0000	<b>PCON</b>	SMOD	-	-	-	GF1	GF0	PD	IDL	
88h	0000-0000	<b>TCON</b>	TF1	TR1	TF0	TR0	IE1	IT1	IE0	IT0	
89h	0000-0000	<b>TMOD</b>	GATE1	CT1N	TMOD1		GATE0	CT0N	TMOD0		
8Ah	0000-0000	<b>TL0</b>	TL0								
8Bh	0000-0000	<b>TL1</b>	TL1								
8Ch	0000-0000	<b>TH0</b>	TH0								
8Dh	0000-0000	<b>TH1</b>	TH1								
8Eh	xxxx-xxxx	<b>TKBDL</b>	TKBHL								
8Fh	xxxx-xxxx	<b>TKBDH</b>	-	-	TKBDH						
90h	1111-1111	<b>P1</b>	P1.7	P1.6	P1.5	P1.4	P1.3	P1.2	P1.1	P1.0	
91h	0101-0101	<b>P0MODL</b>	P0MOD3		P0MOD2		P0MOD1		P0MOD0		
92h	0101-0101	<b>P0MODH</b>	P0MOD7		P0MOD6		P0MOD5		P0MOD4		
93h	0000-0101	<b>PINMOD</b>	TXRXSEL	T2OE	T1OE	T0OE	P2MOD1		P2MOD0		
94h	0000-0000	<b>OPTION</b>	UART1W	TM3CKS	WDTPSC		ADCKS		TM3PSC		
95h	0000-x000	<b>INTFLG</b>	LVDIF	CMPIF	TKIF	ADIF	-	IE2	PXIF	TF3	
96h	0000-0000	<b>PIWKUP</b>	PIWKUP								
97h	xxxx-xx00	<b>SWCMD</b>	SWRST / IAPALL / WDTO								
98h	0000-0000	<b>SCON</b>	SM0	SM1	SM2	REN	TB8	RB8	TI	RI	
99h	xxxx-xxxx	<b>SBUF</b>	SBUF								
9Ah	0000-0000	<b>WGCON</b>	WGRES		WGMOD		WGTDS			WGEN	
9Bh	0000-0000	<b>WGCON2</b>	WGPRD			WGT1H			WGT0H		
9Ch	0000-0000	<b>DACON</b>	SVRF	SVL							
9Dh	1100-0000	<b>CMPCON</b>	CMPPD	CMPOX	CMPOE	CMPIV	CMPTRIG		CMPDBS		
9Eh	1111-0111	<b>CMPPNS</b>	SCMPN	SCIN			OPOF	SCIP			
9Fh	1110-1100	<b>OPCON</b>	OPAPD	SOPP		SOTV	SOPG		SOPM		
A0h	1111-1111	<b>P2</b>	P2.7	P2.6	P2.5	P2.4	P2.3	P2.2	P2.1	P2.0	
A1h	0000-0000	<b>PWMCON</b>	PWM1CKS		PWM1EN	PWM0EN	PWM0CKS		PWM0NMSK	PWM0PMSK	
A2h	0101-0101	<b>P1MODL</b>	P1MOD3		P1MOD2		P1MOD1		P1MOD0		
A3h	0101-0101	<b>P1MODH</b>	P1MOD7		P1MOD6		P1MOD5		P1MOD4		
A4h	0101-0101	<b>P3MODL</b>	P3MOD3		P3MOD2		P3MOD1		P3MOD0		
A5h	0101-0101	<b>P3MODH</b>	P3MOD7		P3MOD6		P3MOD5		P3MOD4		
A6h	0000-0000	<b>PWMOE0</b>	PWM1OE3	PWM1OE2	PWM1OE1	PWM1OE0	PWM0NOE1	PWM0POE1	PWM0NOE0	PWM0POE0	
A7h	0000-0000	<b>PWMCON2</b>	PWM0MOD	PWM0MSKE	PWM0OM		PWM0DZ				
A8h	0x00-0000	<b>IE</b>	EA	-	ET2	ES	ET1	EX1	ET0	EX0	
A9h	0000-0000	<b>INTE1</b>	PWMIE	CMPIE	LVDIE	SPI2CIE	ADTKIE	EX2	PXIE	TM3IE	
AAh	xxxx-xxxx	<b>ADCAL</b>	ADCAL								
ABh	xxxx-xxxx	<b>ADCALH</b>	ADCALH								
ACh	xxxx-xxxx	<b>TKADL</b>	TKADL								
ADh	110x-110x	<b>TKCON</b>	TKAPD	TKAEOC	TKASOC	-	TKBPD	TKBEOC	TKBSOC	-	
A Eh	1111-1000	<b>CHSEL</b>	ADCHS				ADCHS4	ADCVREFS	VBGSEL		
A Fh	xxxx-0000	<b>PILOE</b>	PILOE								
B0h	1111-1111	<b>P3</b>	P3.7	P3.6	P3.5	P3.4	P3.3	P3.2	P3.1	P3.0	
B1h	x000-0000	<b>TKAREFC</b>	TKAREFC								
B2h	xxxx-xxxx	<b>TKADH</b>	TKADH								
B3h	xx11-xx11	<b>TKCHS</b>	TKBCHS				-	-	TKACHS		
B4h	1111-1111	<b>TKATMRL</b>	TKATMRL								
B5h	xx00-0000	<b>TKATMRH</b>	TKATMRH								
B6h	0000-0000	<b>PWMOE1</b>	PWM4OE3	PWM4OE2	PWM4OE1	PWM4OE0	PWM3OE1	PEM3OE0	PWM2OE1	PWM2OE0	
B7h	0000-0000	<b>PWMOE2</b>	MSDASEL	MSCLSEL	PWM6OE2	PWM6OE1	PWM6OE0	PWM5OE2	PWM5OE1	PWM5OE0	
B8h	xx00-0000	<b>IP</b>	-	-	PT2	PS	PT1	PX1	PT0	PX0	
B9h	xx00-0000	<b>IPH</b>	-	-	PT2H	PSH	PT1H	PX1H	PT0H	PX0H	

Adr	RST	NAME	Bit 7	Bit 6	Bit 5	Bit 4	Bit 3	Bit 2	Bit 1	Bit 0
BAh	0000-0000	<b>IP1</b>	PPWM	PCMP	PLVD	PSPI2C	PADTKI	PX2	PPX	PT3
BBh	0000-0000	<b>IP1H</b>	PPWMH	PCMPH	PLVDH	PSPI2CH	PADTKIH	PX2H	PPXH	PT3H
BCh	0000-0000	<b>SPCON</b>	SPEN	MSTR	CPOL	CPHA	–	LSBF	SPCR	
BDh	0000-00xx	<b>SPSTA</b>	SPIF	WCOL	–	RCVOVF	RCVBF	SPBSY	–	–
BEh	0000-0000	<b>SPDAT</b>	SPDAT							
BFh	xxxx-x1xx	<b>BOOTV</b>	–	–	–	–	–	RSTV	BOOTVR	
C1h	1111-1111	<b>TKBTMRL</b>	TKBTMRL							
C2h	xx00-0000	<b>TKBTMRH</b>	–	–	TKBTMRH					
C3h	x000-0000	<b>TKBKCP</b>	–	TKBKCP						
C4h	x000-0000	<b>TKBREFC</b>	–	TKBREFC						
C5h	0000-0000	<b>P0WKUP</b>	P0WKUP							
C6h	0000-0000	<b>P2WKUP</b>	P2WKUP							
C7h	0000-0000	<b>P3WKUP</b>	P3WKUP							
C8h	0000-0000	<b>T2CON</b>	TF2	EXF2	RCLK	TCLK	EXEN2	TR2	CT2N	CPRL2N
C9h	0000-xxxx	<b>IAPCON</b>	IAPCON / IAPWE / EEPWE / INFOWE / IAPTO							
CAh	0000-0000	<b>RCP2L</b>	RCP2L							
CBh	0000-0000	<b>RCP2H</b>	RCP2H							
CCh	0000-0000	<b>TL2</b>	TL2							
CDh	0000-0000	<b>TH2</b>	TH2							
CEh	0000-0000	<b>EXA2</b>	EXA2							
CFh	0000-0000	<b>EXA3</b>	EXA3							
D0h	0000-0000	<b>PSW</b>	CY	AC	F0	RS1	RS0	OV	F1	P
D1h	0000-0000	<b>PWM0DH</b>	PWM0DH							
D2h	0000-0000	<b>PWM0DL</b>	PWM0DL							
D3h	0000-0000	<b>PWM1DH</b>	PWM1DH							
D4h	0000-0000	<b>PWM1DL</b>	PWM1DL							
D5h	0000-0000	<b>PWM2DH</b>	PWM2DH							
D6h	0000-0000	<b>PWM2DL</b>	PWM2DL							
D7h	xxxx-xxxx	<b>CFGOP</b>	–	–	–	OPTRIM				
D8h	xxx0-0011	<b>CLKCON</b>	–	–	STPSCK	STPPCK	STPFCK	SELFCK	CLKPSC	
D9h	1111-1111	<b>PWM0PRDH</b>	PWM0PRDH							
DAh	1111-1111	<b>PWM0PRDL</b>	PWM0PRDL							
DBh	1111-1111	<b>PWM1PRDH</b>	PWM1PRDH							
DCh	1111-1111	<b>PWM1PRDL</b>	PWM1PRDL							
DDh	0000-0000	<b>PWM3DH</b>	PWM3DH							
DEh	0000-0000	<b>PWM3DL</b>	PWM3DL							
DFh	0000-0000	<b>UARTCON</b>	UARTBRS	UARTBRP						
E0h	0000-0000	<b>ACC</b>	ACC.7	ACC.6	ACC.5	ACC.4	ACC.3	ACC.2	ACC.1	ACC.0
E1h	000x-0100	<b>MICON</b>	MIEN	MIACKO	MIIF	MIACKI	MISTART	MISTOP	MICR	
E2h	0000-0000	<b>MIDAT</b>	MIDAT							
E3h	xx00-0000	<b>LVRCON</b>	–	–	PORPD	LVRPD	LVRSEL			
E4h	0000-0000	<b>LVDCON</b>	LVDM	LVDO	LVDHYS	LVDPD	LVDSSEL			
E5h	0000-0000	<b>EFTCON</b>	EFT2CS	EFT1CS	EFT1S		EFTSLOW	EFTWCPU	EFTWOUT	CKHLDE
E6h	0000-0000	<b>EXA</b>	EXA							
E7h	0000-0000	<b>EXB</b>	EXB							
E9h	0000-0000	<b>PWM4DH</b>	PWM4DH							
EAh	0000-0000	<b>PWM4DL</b>	PWM4DL							
EBh	0000-0000	<b>PWM5DH</b>	PWM5DH							
ECh	0000-0000	<b>PWM5DL</b>	PWM5DL							
EDh	0000-0000	<b>PWM6DH</b>	PWM6DH							
EEh	0000-0000	<b>PWM6DL</b>	PWM6DL							
EFh	1110-0011	<b>PWRCON</b>	IVCPD	IVCVS		–	WARMTIME	–	–	–
F0h	0000-0000	<b>B</b>	B.7	B.6	B.5	B.4	B.3	B.2	B.1	B.0
F1h	1111-1111	<b>CRCDL</b>	CRCDL							
F2h	1111-1111	<b>CRCDH</b>	CRCDH							
F3h	0000-0000	<b>CRCIN</b>	CRCIN							
F5h	xxxx-xxxx	<b>CFGBG</b>	–	–	–	BGTRIM				
F6h	xxxx-xxxx	<b>CFGWL</b>	–	FRCTRIM						
F7h	0000-0110	<b>AUX2</b>	WDTE		PWRSVAV	VBGOUT	DIV32	IAPTE		MULDIV16
F8h	0000-1100	<b>AUX1</b>	CLRWDT	CLRTM3	–	ADSOC	CLRPWM0	CLRPWM1	LDOCOUT	DPSEL

Flash Address	NAME	Bit 7	Bit 6	Bit 5	Bit 4	Bit 3	Bit 2	Bit 1	Bit 0
3FF9h	<b>CFGOP</b>	–	–	–	OPTRIM				
3FFBh	<b>CFGBG</b>	–	–	–	BGTRIM				
3FFDh	<b>CFGWL</b>	–	FRCTRIM						
3FFh	<b>CFGWH</b>	PROT	XRSTE	–	HVS	BOOTV		–	–

**SFR & CFGW DESCRIPTION**

Adr	SFR	Bit#	Bit Name	R/W	Rst	Description
80h	<b>P0</b>	7~0	P0	R/W	FFh	Port0 data
81h	<b>SP</b>	7~0	SP	R/W	07h	Stack Point
82h	<b>DPL</b>	7~0	DPL	R/W	00h	Data Point low byte
83h	<b>DPH</b>	7~0	DPH	R/W	00h	Data Point high byte
84h	<b>INTE2</b>	6	PWM1IE	R/W	0	PWM1~PWM6 interrupt enable 0: Disable PWM1~PWM6 interrupt 1: Enable PWM1~PWM6 interrupt
		5	PWM0IE	R/W	0	PWM0 interrupt enable 0: Disable PWM0 interrupt 1: Enable PWM0 interrupt
		1	TKBIE	R/W	0	Touch Key B interrupt enable 0: Disable Touch Key B interrupt 1: Enable Touch Key B interrupt
		0	TKAIE	R/W	0	Touch Key A interrupt enable 0: Disable Touch Key A interrupt 1: Enable Touch Key A interrupt
85h	<b>INTFLG2</b>	6	PWM1IF	R/W	0	PWM1~PWM6 interrupt flag Set by H/W at the end of PWM1 period, S/W writes BFh to INTFLG2 to clear this flag.
		5	PWM0IF	R/W	0	PWM0 interrupt enable Set by H/W at the end of PWM0 period, S/W writes DFh to INTFLG2 to clear this flag.
		1	TKBIF	R/W	0	Touch Key B interrupt flag Set by H/W at the end of TKB scan, S/W writes FDh to INTFLG2 to clear this flag.
		0	TKAIF	R/W	0	Touch Key A interrupt enable Set by H/W at the end of TKA scan, S/W writes FEh to INTFLG2 to clear this flag.
86h	<b>DACON2</b>	3	OPOUT	R/W	0	0:P3.4 as normal IO 1:OPO output to P3.4
		2	DACOUT	R/W	0	0:P2.0 as normal IO 1:DAC output to P2.0
		1	DACBFS	R/W	0	DAC Output Buffer select. 0: Output without Buffer, 1: Output with Buffer
		0	DACPD	R/W	1	DAC Power Down. 0: DAC enable. 1: DAC disable.
87h	<b>PCON</b>	7	SMOD	R/W	0	Set 1 to enable UART double baud rate
		3	GF1	R/W	0	General purpose flag bit
		2	GF0	R/W	0	General purpose flag bit
		1	PD	R/W	0	Power down control bit, set 1 to enter HALT/STOP mode
		0	IDL	R/W	0	Idle control bit, set 1 to enter IDLE mode
88h	<b>TCON</b>	7	TF1	R/W	0	Timer1 overflow flag Set by H/W when Timer/Counter 1 overflows. Cleared by H/W when CPU vectors into the interrupt service routine.
		6	TR1	R/W	0	Timer1 run control. 1: timer runs; 0: timer stops
		5	TF0	R/W	0	Timer0 overflow flag Set by H/W when Timer/Counter 0 overflows. Cleared by H/W when CPU vectors into the interrupt service routine.
		4	TR0	R/W	0	Timer0 run control. 1:timer runs; 0:timer stops
		3	IE1	R/W	0	External Interrupt 1 (INT1 pin) edge flag Set by H/W when an INT1 pin falling edge is detected. Cleared by H/W when CPU vectors into the interrupt service routine.
		2	IT1	R/W	0	External Interrupt 1 control bit 0: Low level active (level triggered) for INT1 pin 1: Falling edge active (edge triggered) for INT1 pin
		1	IE0	R/W	0	External Interrupt 0 (INT0 pin) edge flag Set by H/W when an INT0 pin falling edge is detected. Cleared by H/W when CPU vectors into the interrupt service routine.

Adr	SFR	Bit#	Bit Name	R/W	Rst	Description
		0	IT0	R/W	0	External Interrupt 0 control bit 0: Low level active (level triggered) for INT0 pin 1: Falling edge active (edge triggered) for INT0 pin
89h	<b>TMOD</b>	7	GATE1	R/W	0	Timer1 gating control bit 0: Timer1 enable when TR1 bit is set 1: Timer1 enable only while the INT1 pin is high and TR1 bit is set
		6	CT1N	R/W	0	Timer1 Counter/Timer select bit 0: Timer mode, Timer1 data increases at 2 System clock cycle rate 1: Counter mode, Timer1 data increases at T1 pin's negative edge
		5~4	TMOD1	R/W	00	Timer1 mode select 00: 8-bit timer/counter (TH1) and 5-bit prescaler (TL1) 01: 16-bit timer/counter 10: 8-bit auto-reload timer/counter (TL1). Reloaded from TH1 at overflow. 11: Timer1 stops
		3	GATE0	R/W	0	Timer0 gating control bit 0: Timer0 enable when TR0 bit is set 1: Timer0 enable only while the INT0 pin is high and TR0 bit is set
		2	CT0N	R/W	0	Timer0 Counter/Timer select bit 0: Timer mode, Timer0 data increases at 2 System clock cycle rate 1: Counter mode, Timer0 data increases at T0 pin's negative edge
		1~0	TMOD0	R/W	00	Timer0 mode select 00: 8-bit timer/counter (TH0) and 5-bit prescaler (TL0) 01: 16-bit timer/counter 10: 8-bit auto-reload timer/counter (TL0). Reloaded from TH0 at overflow. 11: TL0 is an 8-bit timer/counter. TH0 is an 8-bit timer/counter using Timer1's TR1 and TF1 bits.
8Ah	<b>TL0</b>	7~0	TL0	R/W	00h	Timer0 data low byte
8Bh	<b>TL1</b>	7~0	TL1	R/W	00h	Timer1 data low byte
8Ch	<b>TH0</b>	7~0	TH0	R/W	00h	Timer0 data high byte
8Dh	<b>TH1</b>	7~0	TH1	R/W	00h	Timer1 data high byte
8Eh	<b>TKBDL</b>	7~0	TKBDL	R	-	TKB data low byte
8Fh	<b>TKBDH</b>	5~0	TKBDH	R	-	TKB data high byte
90h	<b>P1</b>	7~0	P1	R/W	FFh	Port1 data
91h	<b>P0MODL</b>	7~6	P0MOD3	R/W	01	P0.3 Pin Control 00: Mode0; 01: Mode1; 10: Mode2; 11: Mode3
		5~4	P0MOD2	R/W	01	P0.2 Pin Control 00: Mode0; 01: Mode1; 10: Mode2; 11: Mode3
		3~2	P0MOD1	R/W	01	P0.1 Pin Control 00: Mode0; 01: Mode1; 10: Mode2; 11: Mode3
		1~0	P0MOD0	R/W	01	P0.0 Pin Control 00: Mode0; 01: Mode1; 10: Mode2; 11: Mode3
92h	<b>P0MODH</b>	7~6	P0MOD7	R/W	01	P0.7 Pin Control 00: Mode0; 01: Mode1; 10: Mode2; 11: Mode3
		5~4	P0MOD6	R/W	01	P0.6 Pin Control 00: Mode0; 01: Mode1; 10: Mode2; 11: Mode3
		3~2	P0MOD5	R/W	01	P0.5 Pin Control 00: Mode0; 01: Mode1; 10: Mode2; 11: Mode3
		1~0	P0MOD4	R/W	01	P0.4 Pin Control 00: Mode0; 01: Mode1; 10: Mode2; 11: Mode3



Adr	SFR	Bit#	Bit Name	R/W	Rst	Description
93h	PINMOD	7	TXRXSEL	R/W	0	UART TXD/RXD pin select 0: P31 as TXD, P30 as RXD 1: P16 as TXD, P02 as RXD
		6	T2OE	R/W	0	Timer2 signal output (T2O) control 0: Disable "Timer2 overflow divided by 2" output to P1.0 pin 1: Enable "Timer2 overflow divided by 2" output to P1.0 pin
		5	T1OE	R/W	0	Timer1 signal output (T1O) control 0: Disable "Timer1 overflow divided by 2" output to P3.5 pin 1: Enable "Timer1 overflow divided by 2" output to P3.5 pin
		4	T0OE	R/W	0	Timer0 signal output (T0O) control 0: Disable "Timer0 overflow divided by 64" output to P3.4 pin 1: Enable "Timer0 overflow divided by 64" output to P3.4 pin
		3~2	P2MOD1	R/W	01	P2.1 Pin Control 00: Mode0; 01: Mode1; 10: Mode2; 11: Mode3
		1~0	P2MOD0	R/W	01	P2.0 Pin Control 00: Mode0; 01: Mode1; 10: Mode2; 11: Mode3
94h	OPTION	7	UART1W	R/W	0	Set 1 to enable one wire UART mode, both TXD/RXD use P3.1 pin or P1.6.
		6	TM3CKS	R/W	0	Timer3 clock source select. 0: Slow Clock (SRC) 1: SRC/0.75
		5~4	WDTPSC	R/W	00	Watchdog Timer pre-scalar time select 00: 400ms WDT overflow rate 01: 200ms WDT overflow rate 10: 100ms WDT overflow rate 11: 50ms WDT overflow rate
		3~2	ADCKS	R/W	00	ADC clock rate select 00: F <sub>SYSClk</sub> /32 01: F <sub>SYSClk</sub> /16 10: F <sub>SYSClk</sub> /8 11: F <sub>SYSClk</sub> /4
		1~0	TM3PSC	R/W	00	Timer3 prescaler. 00: 32768 clock cycle 01: 4096 clock cycle 10: 2048 clock cycle 11: 512 clock cycle
95h	INTFLG	7	LVDIF	R/W	0	LVD interrupt flag Set by H/W when V <sub>CC</sub> less than the LVD voltage. S/W writes 7Fh to INTFLG to clear this flag.
		6	CMPIF	R/W	0	CMP interrupt flag Set by H/W while CMPO match trigger condition. It is cleared automatically when the program performs the interrupt service routine. S/W writes BFh to INTFLG to clear this flag.
		5	TKIF	R/W	0	Touch Key interrupt flag Set by H/W at the end of TK conversion. S/W writes DFh to INTFLG or sets the TKSOC bit to clear this flag. When user clears this flag, H/W will automatically clear TKAIF and TKBIF.
		4	ADIF	R/W	0	ADC interrupt flag Set by H/W at the end of ADC conversion. S/W writes EFh to INTFLG or sets the ADSOC bit to clear this flag.
		2	IE2	R/W	0	External Interrupt 2 (INT2 pin) edge flag Set by H/W when a falling edge is detected on the INT2 pin, no matter the EX2 is 0 or 1. It is cleared automatically when the program performs the interrupt service routine. S/W can write FBh to INTFLG to clear this bit.

Adr	SFR	Bit#	Bit Name	R/W	Rst	Description	
		1	PXIF	R/W	0	Port0~3 pin change Interrupt flag Set by H/W when a Port0~3 pin state change is detected and its interrupt enable bit is set (P0WKUP/P1WKUP/P2WKUP/P3WKUP). PXIE does not affect this flag's setting. It is cleared automatically when the program performs the interrupt service routine. S/W can write FDh to INTFLG to clear this bit.	
		0	TF3	R/W	0	Timer3 interrupt flag. Set by H/W when Timer3 reaches TM3PSC setting cycles. It is cleared automatically when the program performs the interrupt service routine. S/W can write FEh to INTFLG to clear this bit.	
96h	<b>P1WKUP</b>	7~0	P1WKUP	R/W	00h	P1.7~P1.0 pin individual Wake-up/Interrupt enable control 0: Disable; 1: Enable.	
97h	<b>SWCMD</b>	7~0	SWRST	W		Write 56h to generate S/W Reset	
		7~0	IAPALL	W		Write 65h to set IAPALL flag. Write other value to clear IAPALL flag.	
		1	WDTO	R	0	Watchdog Time-Out flag	
		0	IAPALL	R	0	Flag indicates Flash can be written by IAP or not 0: Flash IAP disable 1: Flash IAP enable, only for BOOT mode upgrade APP area.	
98h	<b>SCON</b>	7	SM0	R/W	0	UART Serial port mode select bit 0, 1 (SM0, SM1) = 00: Mode0: 8 bit shift register, Baud Rate= $F_{SYSCLK}/2$ 01: Mode1: 8 bit UART, Baud Rate is variable 10: Mode2: 9 bit UART, Baud Rate= $F_{SYSCLK}/32$ or $/64$ 11: Mode3: 9 bit UART, Baud Rate is variable	
		6	SM1	R/W	0		
		5	SM2	R/W	0		Serial port mode select bit 2 SM2 enables multiprocessor communication over a single serial line and modifies the above as follows. In Modes 2 & 3, if SM2 is set then the received interrupt will not be generated if the received ninth data bit is 0. In Mode 1, the received interrupt will not be generated unless a valid stop bit is received. In Mode 0, SM2 should be 0.
		4	REN	R/W	0		Set 1 to enable UART Reception
		3	TB8	R/W	0	Transmitter bit 8, ninth bit to transmit in Modes 2 and 3	
		2	RB8	R/W	0	Receive Bit 8, contains the ninth bit that was received in Mode 2 and 3 or the stop bit is Mode 1 if SM2=0	
		1	TI	R/W	0	Transmit Interrupt flag Set by H/W at the end of the eighth bit in Mode 0, or at the beginning of the stop bit in other modes. Must be cleared by S/W	
		0	RI	R/W	0	Receive Interrupt flag Set by H/W at the end of the eighth bit in Mode 0, or at the sampling point of the stop bit in other modes. Must be cleared by S/W.	
99h	<b>SBUF</b>	7~0	SBUF	R/W	-	UART transmit and receive data. Transmit data is written to this location and receive data is read from this location, but the paths are independent.	
9Ah	<b>WGCON</b>	7~6	WGRES	R/W	00	WG reset time select ( $T_{FRC} = 60.28$ ns) 0: $7 * T_{FRC} = 54.0\mu s$ 1: $11 * T_{FRC} = 84.9\mu s$ 2: $21 * T_{FRC} = 162.0\mu s$ 3: $37 * T_{FRC} = 285.5\mu s$	
		5~4	WGMOD	R/W	00	WG Mode select 0xb: Continue Mode. HW sends data code and reset code, repeating continuously, will not clear WGEN automatically. 10b: One Cycle Mode. HW will automatically clear WGEN after sending data code and reset code 11b: One Cycle Mode. HW will automatically clear WGEN after sending data code.	
		3~1	WGTDS	R/W	000	WG Transmit data length select 0: 3 bytes (1 LED) 1: 6 bytes (2 LED) 2: 9 bytes (3 LED)	

Adr	SFR	Bit#	Bit Name	R/W	Rst	Description
						3: 12 bytes (4 LED) 4: 15 bytes (5 LED) 5: 18 bytes (6 LED) 6: 21 bytes (7 LED) 7: 24 bytes (8 LED)
		0	WGEN	R/W	0	WG enable and output to P3.4, H/W will automatically clear WGEN in One Cycle mode 0: WG disable, P3.4 as GPIO。 1: WG enable, P3.4 as WG output.
9Bh	WGCON2	7~5	WGPRD	R/W	000	WG period of each bit select ( $T_{FRC} = 60.28 \text{ ns}$ ) 0: $17 * T_{FRC} = 1025 \text{ ns}$ 1: $18 * T_{FRC} = 1085 \text{ ns}$ 2: $19 * T_{FRC} = 1145 \text{ ns}$ 3: $20 * T_{FRC} = 1206 \text{ ns}$ 4: $21 * T_{FRC} = 1266 \text{ ns}$ 5: $22 * T_{FRC} = 1326 \text{ ns}$ 6: $23 * T_{FRC} = 1386 \text{ ns}$ 7: $24 * T_{FRC} = 1447 \text{ ns}$
		4~2	WGT1H	R/W	000	WG code 1 high level time select ( $T_{FRC} = 60.28 \text{ ns}$ ) 0: $10 * T_{FRC} = 603 \text{ ns}$ 1: $11 * T_{FRC} = 663 \text{ ns}$ 2: $12 * T_{FRC} = 723 \text{ ns}$ 3: $13 * T_{FRC} = 784 \text{ ns}$ 4: $14 * T_{FRC} = 844 \text{ ns}$ 5: $15 * T_{FRC} = 904 \text{ ns}$ 6: $16 * T_{FRC} = 964 \text{ ns}$ 7: $17 * T_{FRC} = 1025 \text{ ns}$
		1~0	WGT0H	R/W	00	WG code 0 high level time select ( $T_{FRC} = 60.28 \text{ ns}$ ) 0: $4 * T_{FRC} = 241 \text{ ns}$ 1: $5 * T_{FRC} = 301 \text{ ns}$ 2: $6 * T_{FRC} = 362 \text{ ns}$ 3: $7 * T_{FRC} = 422 \text{ ns}$
9Ch	DACON	7	SVRF	R/W	0	Select comparator reference voltage level 0: VDDA 1: VBGO (define by VBGSEL AEh.1~0)
		6~0	SVL	R/W	0	Select DAC output voltage reference source can be selected as VDDA or VBGO 000_0000: 0/128 * reference source 000_0001: 1/128 * reference source ... 111_1101: 125/128 * reference source 111_1110: Reserved 111_1111: Reserved
9Dh	CMPCON	7	CMPPD	R/W	1	Comparator & DAC power down enable control 0: disable Comparator & DAC power down 1: enable Comparator & DAC power down
		6	CMPOX	R/W	1	Comparator original output (CMPOX) status 0: $V_{CMPP} < V_{CMPN}$ 1: $V_{CMPP} > V_{CMPN}$ or $CMPPD = 1$
		5	CMPOE	R/W	0	Comparator output (CMPO) signal output to P2.1 0: disable 1: enable, P2MOD1 should be set to 10b
		4	CMPINV	R/W	0	Comparator de-bounce output invert select 0: no invert 1: invert
		3~2	CMPTRIG	R/W	00	Comparator interrupt trigger mode 00: Rising edge 01: Falling edge 10: Both edge 11: High level
		1~0	CMPDBS	R/W	00	Comparator original output (CMPOX) de-bounce time 00: none 01: 4 Fsys

Adr	SFR	Bit#	Bit Name	R/W	Rst	Description
						10: 8 Fsys 11: 16 Fsys
9Eh	CMPPNS	7	SCMPN	R/W	1	Comparator CMPN source select 0: Comparator CMPN source is external input (CINx) 1: Comparator CMPN source is DAC output
		6~4	SCIN	R/W	111	Comparator CMPN external input select 000: Comparator CMPN external input is CIN1 (P1.6) 001: Comparator CMPN external input is CIN2 (P1.5) 010: Comparator CMPN external input is CIN3 (P0.7) 011: Comparator CMPN external input is CIN4 (P0.1) 1xx: No connect
		3	OPOF	R/W	0	OPA output (OPO) connect to Comparator CMPP 0: Comparator CMPP source is OPA output (OPO) 1: Comparator CMPP source is external input (CIPx)
		2~0	SCIP	R/W	111	Comparator CMPP external input select 000: Comparator CMPP external input is CIP1 (PA1) 001: Comparator CMPP external input is CIP2 (PA2) 010: Comparator CMPP external input is CIP3 (PB6) 011: Comparator CMPP external input is CIP4 (PD1) 1xx: No connect
9Fh	OPCON	7	OPAPD	R/W	1	OPA power down enable control 0: disable OPA power down 1: enable OPA power down
		6~5	SOPP	R/W	11	select OPP input source 00: OPP input source is P3.3 01: OPP input source is P1.4 10: OPP input source is P1.7 11: OPP input source is VSS
		4	SOTV	R/W	0	OPN input voltage selection in Comparator mode 0: VSS 1: VBG (voltage level is selected by VBGSEL)
		3~2	SOPG	R/W	11	select OPA gain 00: 1X 01: 20X 10: 50X 11: 100X
		1~0	SOPM	R/W	00	select OPA operating mode 00: Normal Mode 01: Reserved 10: Reserved 11: Comparator Mode
A0h	P2	7~2	P2.7~P2.2	R/W	FFh	P2.7~P2.2 have no pin out, so these bits are used as general purpose register
		1~0	P2.1~P2.0	R/W	11	P2.1~P2.0 data
A1h	PWMCON	7~6	PWM1CKS	R/W	00	PWM1 clock source 00: F <sub>SYSC</sub> CLK 01: F <sub>SYSC</sub> CLK 10: FRC 11: FRCx2 (V <sub>cc</sub> >2.7V)
		5	PWM1EN	R/W	0	PWM1~6 Enable. 0: PWM1~6 Disable, 1: PWM1~6 Enable
		4	PWM0EN	R/W	0	PWM0 Enable. 0: PWM0 Disable, 1: PWM0 Enable
		3~2	PWM0CKS	R/W	00	PWM0 clock source 00: F <sub>SYSC</sub> CLK 01: F <sub>SYSC</sub> CLK 10: FRC 11: FRCx2 (V <sub>cc</sub> >2.7V)
		1	PWM0NMSK	R/W	0	PWM0N mask data. If CLRPWM0=1 and PMW0MSKE=1, PWM0N will output this mask data.
		0	PWM0PMSK	R/W	0	PWM0P mask data. If CLRPWM0=1 and PMW0MSKE=1, PWM0P will output this mask data.
A2h	P1MODL	7~6	P1MOD3	R/W	01	P1.3 Pin Control

Adr	SFR	Bit#	Bit Name	R/W	Rst	Description
						00: Mode0; 01: Mode1; 10: Mode2; 11: Mode3
		5~4	P1MOD2	R/W	01	P1.2 Pin Control 00: Mode0; 01: Mode1; 10: Mode2; 11: Mode3
		3~2	P1MOD1	R/W	01	P1.1 Pin Control 00: Mode0; 01: Mode1; 10: Mode2; 11: Mode3
		1~0	P1MOD0	R/W	01	P1.0 Pin Control 00: Mode0; 01: Mode1; 10: Mode2; 11: Mode3
A3h	<b>P1MODH</b>	7~6	P1MOD7	R/W	01	P1.7 Pin Control 00: Mode0; 01: Mode1; 10: Mode2; 11: Mode3
		5~4	P1MOD6	R/W	01	P1.6 Pin Control 00: Mode0; 01: Mode1; 10: Mode2; 11: Mode3
		3~2	P1MOD5	R/W	01	P1.5 Pin Control 00: Mode0; 01: Mode1; 10: Mode2; 11: Mode3
		1~0	P1MOD4	R/W	01	P1.4 Pin Control 00: Mode0; 01: Mode1; 10: Mode2; 11: Mode3
A4h	<b>P3MODL</b>	7~6	P3MOD3	R/W	01	P3.3 Pin Control 00: Mode0; 01: Mode1; 10: Mode2; 11: Mode3
		5~4	P3MOD2	R/W	01	P3.2 Pin Control 00: Mode0; 01: Mode1; 10: Mode2; 11: Mode3
		3~2	P3MOD1	R/W	01	P3.1 Pin Control 00: Mode0; 01: Mode1; 10: Mode2; 11: Mode3
		1~0	P3MOD0	R/W	01	P3.0 Pin Control 00: Mode0; 01: Mode1; 10: Mode2; 11: Mode3
A5h	<b>P3MODH</b>	7~6	P3MOD7	R/W	01	P3.7 Pin Control 00: Mode0; 01: Mode1; 10: Mode2; 11: Mode3
		5~4	P3MOD6	R/W	01	P3.6 Pin Control 00: Mode0; 01: Mode1; 10: Mode2; 11: Mode3
		3~2	P3MOD5	R/W	01	P3.5 Pin Control 00: Mode0; 01: Mode1; 10: Mode2; 11: Mode3
		1~0	P3MOD4	R/W	01	P3.4 Pin Control 00: Mode0; 01: Mode1; 10: Mode2; 11: Mode3
A6h	<b>PWMOE0</b>	7	PWM1OE3	R/W	0	PWM1 output control 0: Disable 1: PWM1 enable and output to P1.2
		6	PWM1OE2	R/W	0	PWM1 output control 0: Disable 1: PWM1 enable and output to P0.6
		5	PWM1OE1	R/W	0	PWM1 output control 0: Disable 1: PWM1 enable and output to P0.4
		4	PWM1OE0	R/W	0	PWM1 output control 0: Disable 1: PWM1 enable and output to P0.2
		3	PWM0NOE1	R/W	0	PWM0N output control 0: Disable 1: PWM0N enable and output to P3.6
		2	PWM0POE1	R/W	0	PWM0P output control 0: Disable 1: PWM0P enable and output to P3.5
		1	PWM0NOE0	R/W	0	PWM0N output control 0: Disable 1: PWM0N enable and output to P0.4
		0	PWM0POE0	R/W	0	PWM0P output control 0: Disable 1: PWM0P enable and output to P0.3
A7h	<b>PWMCON2</b>	7	PWM0MOD	R/W	0	PWM0 mode select 0: Normal mode 1: Half-bridge mode
		6	PWM0MSKE	R/W	0	PWM0 mask output enable 0: Disable 1: Enable, PWM0P/PWM0N output data by PWM0PMSK/PWM0NMSK while CLRPWM0=1
		5~4	PWM0OM	R/W	00	PWM0 output mode select 00: Mode0 01: Mode1 10: Mode2 11: Mode3

Adr	SFR	Bit#	Bit Name	R/W	Rst	Description
		3~0	PWM0DZ	R/W	0000	PWM0 dead zone (Dead zone is prohibited in half-bridge mode) 0000: 0 x T <sub>PWMCLK</sub> 0001: 1 x T <sub>PWMCLK</sub> ... 1111: 15 x T <sub>PWMCLK</sub>
A8h	IE	7	EA	R/W	0	Global interrupt enable control. 0: Disable all Interrupts. 1: Each interrupt is enabled or disabled by its own interrupt control bit.
		5	ET2	R/W	0	Set 1 to enable Timer2 interrupt
		4	ES	R/W	0	Set 1 to enable Serial Port (UART) Interrupt
		3	ET1	R/W	0	Set 1 to enable Timer1 Interrupt
		2	EX1	R/W	0	Set 1 to enable external INT1 pin Interrupt & Halt/Stop mode wake up capability
		1	ET0	R/W	0	Set 1 to enable Timer0 Interrupt
		0	EX0	R/W	0	Set 1 to enable external INT0 pin Interrupt & Halt/Stop mode wake up capability
A9h	INTE1	7	PWMIE	R/W	0	Set 1 to enable PWM0/PWM1~PWM6 interrupt
		6	CMPIE	R/W	0	Set 1 to enable CMP interrupt
		5	LVDIE	R/W	0	Set 1 to enable LVD interrupt
		4	SPI2CE	R/W	0	Set 1 to enable SPI/I <sup>2</sup> C interrupt
		3	ADTKIE	R/W	0	Set 1 to enable ADC/TK Interrupt
		2	EX2	R/W	0	Set 1 to enable external INT2 pin Interrupt & Halt/Stop mode wake up capability
		1	PXIE	R/W	0	Set 1 to enable Port0/Port1/Port2/Port3 Pin Change Interrupt
AAh	ADCDL	7~4	ADCDL	R	-	ADC data bit 3~0
		0	PWRDEC	W	0	ROM parameter settings for high temperature writing.
ABh	ADCDH	7~0	ADCDH	R	-	ADC data bit 11~4
ACH	TKADL	7~0	TKADL	R	-	
ADh	TKCON	7	TKAPD	R/W	1	Touch Key A power down.
		6	TKAEOC	R	1	Touch Key A end of conversion.
		5	TKASOC	R/W	0	Touch Key A start, HW clear while end of conversion.
		4	-	-	0	Reserved
		3	TKBPD	R/W	1	Touch Key B power down.
		2	TKBEOC	R	1	Touch Key B end of conversion.
		1	TKBSOC	R/W	0	Touch Key B start, HW clear while end of conversion.
		0	-	-	0	Reserved

Adr	SFR	Bit#	Bit Name	R/W	Rst	Description
AEh	CHSEL	7~3	ADCHS	R/W	11111	ADC channel select. 00000: AD0 (P0.4) 00001: AD1 (P0.3) 00010: AD2 (P1.0) 00011: AD3 (P1.1) 00100: AD4 (P3.3) 00101: AD5 (P3.2) 00110: AD6 (P3.0) 00111: AD7 (P3.1) 01000: AD8 (P3.4) 01001: AD9 (P1.7) 01010: AD10 (P0.7) 01011: AD11 (P0.5) 01100: VBG 01101: OPO 01110: V <sub>SS</sub> 01111: AD15 (P0.2) 10000: AD16 (P1.3) 10001: AD17 (P1.4) 10010: AD18 (P1.5) 10011: AD19 (P1.6) 10100: AD20 (P0.0) 10101: AD21 (P0.1) 10110: Reserved 10111: V <sub>CC</sub> /4 others: Reserved
		2	ADCVREFS	R/W	0	ADC reference voltage 0: V <sub>CC</sub> 1: VBG
		1~0	VBGSEL	R/W	00	VBG voltage select, When ADCVREF is selected as VBG, VBGSEL is prohibited from using 1.20V. 00: 1.20V 01: 2.49V (need VCC>2.8V) 10: Reserved 11: Reserved
AFh	PILOE	3~0	PILOE	R/W	0000	P1.5~P1.2 (COM3~0) LCD 1/2 bias output enable.
B0h	P3	7~0	P3	R/W	FFh	Port3 data
B1h	TKAREFC	6~0	TKAREFC	R/W	00h	Touch Key A reference clock capacitor select.
B2h	TKADH	5~0	TKADH	R	-	Touch Key A Data bit13~bit8
B3h	TKCHS	5~4	TKBCHS	R/W	11	Touch Key B channel select. 00:TK4 (P1.1) 01:TK5 (P0.5) 10:TK6 (P0.6) 11: TK7 (P0.7) (Ref)
		1~0	TKACHS	R/W	11	Touch Key A channel select. 00: TK0 (P3.7) 01: TK1 (P2.1) 10: TK2 (P2.0) 11: TK3 (P1.2)
B4h	TKATMRL	7~0	TKATMRL	R/W	FF	Touch Key A reference counter data 7~0
B5h	TKATMRH	5~0	TKATMRH	R/W	00	Touch Key A reference counter data 13~8
B6h	PWMOE1	7	PWM4OE3	R/W	0	PWM4 output control 0: Disable      1: PWM4 enable and output to P3.6
		6	PWM4OE2	R/W	0	PWM4 output control 0: Disable      1: PWM4 enable and output to P1.5
		5	PWM4OE1	R/W	0	PWM4 output control 0: Disable      1: PWM4 enable and output to P0.4

Adr	SFR	Bit#	Bit Name	R/W	Rst	Description
		4	PWM4OE0	R/W	0	PWM4 output control 0: Disable 1: PWM4 enable and output to P0.0
		3	PWM3OE1	R/W	0	PWM3 output control 0: Disable 1: PWM3 enable and output to P3.4
		2	PWM3OE0	R/W	0	PWM3 output control 0: Disable 1: PWM3 enable and output to P1.0
		1	PWM2OE1	R/W	0	PWM2 output control 0: Disable 1: PWM2 enable and output to P3.6
		0	PWM2OE0	R/W	0	PWM2 output control 0: Disable 1: PWM2 enable and output to P1.1
B7h	PWMOE2	7	MSDASEL	R/W	0	Master I <sup>2</sup> C SDA select 0: P3.5 as Master I <sup>2</sup> C SDA 1: P1.6 as Master I <sup>2</sup> C SDA
		6	MSCLSEL	R/W	0	Master I <sup>2</sup> C SCL select 0: P1.3 as Master I <sup>2</sup> C SCL 1: P0.2 as Master I <sup>2</sup> C SCL
		5	PWM6OE2	R/W	0	PWM6 output control 0: Disable 1: PWM6 enable and output to P1.3
		4	PWM6OE1	R/W	0	PWM6 output control 0: Disable 1: PWM6 enable and output to P0.7
		3	PWM6OE0	R/W	0	PWM6 output control 0: Disable 1: PWM6 enable and output to P0.3
		2	PWM5OE2	R/W	0	PWM5 output control 0: Disable 1: PWM5 enable and output to P1.4
		1	PWM5OE1	R/W	0	PWM5 output control 0: Disable 1: PWM5 enable and output to P0.6
		0	PWM5OE0	R/W	0	PWM5 output control 0: Disable 1: PWM5 enable and output to P0.1
B8h	IP	5	PT2	R/W	0	Timer2 Interrupt Priority Low bit
		4	PS	R/W	0	Serial Port (UART) Interrupt Priority Low bit
		3	PT1	R/W	0	Timer1 Interrupt Priority Low bit
		2	PX1	R/W	0	External INT1 Pin Interrupt Priority Low bit
		1	PT0	R/W	0	Timer0 Interrupt Priority Low bit
		0	PX0	R/W	0	External INT0 Pin Interrupt Priority Low bit
B9h	IPH	5	PT2H	R/W	0	Timer2 Interrupt Priority High bit
		4	PSH	R/W	0	Serial Port (UART) Interrupt Priority High bit
		3	PT1H	R/W	0	Timer1 Interrupt Priority High bit
		2	PX1H	R/W	0	External INT1 Pin Interrupt Priority High bit
		1	PT0H	R/W	0	Timer0 Interrupt Priority High bit
		0	PX0H	R/W	0	External INT0 Pin Interrupt Priority High bit
BAh	IP1	7	PPWM	R/W	0	PWM0/PWM1 Interrupt Priority Low bit
		6	PCMP	R/W	0	CMP Interrupt Priority Low bit
		5	PLVD	R/W	0	LVD Interrupt Priority Low bit
		4	PSPI2C	R/W	0	SPI/I <sup>2</sup> C Interrupt Priority Low bit
		3	PADTKI	R/W	0	ADC/TK Interrupt Priority Low bit
		2	PX2	R/W	0	External INT2 Pin Interrupt Priority Low bit
		1	PPX	R/W	0	Port0~Port3 pin change Interrupt Priority Low bit
		0	PT3	R/W	0	Timer3 Interrupt Priority Low bit



Adr	SFR	Bit#	Bit Name	R/W	Rst	Description
BBh	IP1H	7	PPWMH	R/W	0	PWM0/PWM1 Interrupt Priority High bit
		6	PCMPH	R/W	0	CMP Interrupt Priority High bit
		5	PLVDH	R/W	0	LVD Interrupt Priority High bit
		4	PI2CH	R/W	0	SPI/I <sup>2</sup> C Interrupt Priority High bit
		3	PADTKIH	R/W	0	ADC/TK Interrupt Priority High bit
		2	PX2H	R/W	0	External INT2 Pin Interrupt Priority High bit
		1	PPXH	R/W	0	Port0~Port3 Interrupt Priority High bit
		0	PT3H	R/W	0	Timer3 Interrupt Priority High bit
BCh	SPCON	7	SPEN	R/W	0	SPI Enable
		6	MSTR	R/W	0	Master Mode Enable
		5	CPOL	R/W	0	SPI Clock Polarity
		4	CPHA	R/W	0	SPI Clock Phase
		2	LSBF	R/W	0	LSB First. 0: MSB first, 1: LSB first
		1~0	SPCR	R/W	00	SPI Clock Rate. 0: F <sub>SYS</sub> /2, 1: F <sub>SYS</sub> /4, 2: F <sub>SYS</sub> /8, 3: F <sub>SYS</sub> /16
BDh	SPSTA	7	SPIF	R/W	0	SPI Interrupt Flag
		6	WCOL	R/W	0	Write Collision Interrupt Flag
		4	RCVOVF	R/W	0	Receive Buffer Overrun Flag
		3	RCVBF	R/W	0	Receive Buffer Full Flag
		2	SPBSY	R	0	SPI Busy Flag
BEh	SPDAT	7~0	SPDAT	R/W	00h	SPI Transmit and Receive Data
BFh	BOOTV	2	RSTV	R/W	1	Reset Vector after Reset. No change while Reset (except POR) 0: Reset Vector = 0x0000 1: Reset Vector define by BOOTVR (CFG.BOOTV)
		1~0	BOOTVR	R	-	Load from CFG.BOOTV after POR. 00: Reset Vector = 0x3800, BOOT Area Size = 2K 01: Reset Vector = 0x3000, BOOT Area Size = 4K 1x: Reset Vector = 0x0000, no BOOT Area
C1h	TKBTMRL	7~0	TKBTMRL	R/W	FFh	Touch Key B reference counter data 7~0
C2h	TKBTMRH	5~0	TKBTMRH	R/W	00h	Touch Key B reference counter data 13~8
C3h	TKBKCP	6~0	TKBKCP	R/W	00h	Touch Key B reference capacitor select (TK7)
C4h	TKBREFC	6~0	TKBREFC	R/W	00h	Touch Key B reference clock capacitor select
C5h	P0WKUP	7~0	P0WKUP	R/W	00h	P0.7~P0.0 pin individual Wake-up/Interrupt enable control 0: Disable; 1: Enable.
C6h	P2WKUP	7~0	P2WKUP	R/W	00h	P2.7~P2.0 pin individual Wake-up/Interrupt enable control 0: Disable; 1: Enable.
C7h	P3WKUP	7~0	P3WKUP	R/W	00h	P3.7~P3.0 pin individual Wake-up/Interrupt enable control 0: Disable; 1: Enable.
C8h	T2CON	7	TF2	R/W	0	Timer2 overflow flag Set by H/W when Timer/Counter 2 overflows unless RCLK=1 or TCLK=1. This bit must be cleared by S/W.
		6	EXF2	R/W	0	T2EX interrupt pin falling edge flag Set when a capture or a reload is caused by a negative transition on T2EX pin if EXEN2=1. This bit must be cleared by S/W.
		5	RCLK	R/W	0	UART receive clock control bit 0: Use Timer1 overflow as receive clock for serial port in mode 1 or 3 1: Use Timer2 overflow as receive clock for serial port in mode 1 or 3
		4	TCLK	R/W	0	UART transmit clock control bit 0: Use Timer1 overflow as transmit clock for serial port in mode 1 or 3 1: Use Timer2 overflow as transmit clock for serial port in mode 1 or 3
		3	EXEN2	R/W	0	T2EX pin enable 0: T2EX pin disable 1: T2EX pin enable, it cause a capture or reload when a negative transition on T2EX pin is detected if RCLK=TCLK=0

Adr	SFR	Bit#	Bit Name	R/W	Rst	Description
		2	TR2	R/W	0	Timer2 run control 0:timer stops 1:timer runs
		1	CT2N	R/W	0	Timer2 Counter/Timer select bit 0: Timer mode, Timer2 data increases at 2 System clock cycle rate 1: Counter mode, Timer2 data increases at T2 pin's negative edge
		0	CPRL2N	R/W	0	Timer2 Capture/Reload control bit 0: Reload mode, auto-reload on Timer2 overflows or negative transitions on T2EX pin if EXEN2=1. 1: Capture mode, capture on negative transitions on T2EX pin if EXEN2=1. If RCLK=1 or TCLK=1, CPRL2N is ignored and timer is forced to auto-reload on Timer2 overflow.
C9h	IAPCON	7~0	IAPCON	W	-	Write 47h or 74h to set IAPWE flag; Write 47h can write 1 byte at once, write 74h can write 2 bytes at once. Write other value to clear IAPWE flag. It is recommended to clear it immediately after IAP write. Write A1h to set INFOWE flag; write other value to clear INFOWE flag. It is recommended to clear it immediately after IAP write. Write E2h to set EEPWE flag; write other value to clear EEPWE flag. It is recommended to clear it immediately after EEPROM write.
		7	IAPWE	R	0	Flag indicates Flash memory can be written by IAP or not 0: IAP Write disable 1: IAP Write enable
		6	IAPTO	R	0	Time-Out flag of IAP write/EEPROM write/INFO write. Set by H/W when IAP or EEPROM or INFO write Time-out occurs. Cleared this flag by H/W when IAPWE=0 or EEPWE=0 or INFOWE=0.
		5	EEPWE	R	0	Flag indicates EEPROM memory can be written or not 0: EEPROM Write disable 1: EEPROM Write enable
		4	INFOWE	R	0	Flag indicates INFO memory can be written or not 0: INFO IAP Write disable 1: INFO IAP Write enable
CAh	RCP2L	7~0	RCP2L	R/W	00h	Timer2 reload/capture data low byte
CBh	RCP2H	7~0	RCP2H	R/W	00h	Timer2 reload/capture data high byte
CCh	TL2	7~0	TL2	R/W	00h	Timer2 data low byte
CDh	TH2	7~0	TH2	R/W	00h	Timer2 data high byte
CEh	EXA2	7~0	EXA2	R/W	00h	Expansion accumulator 2
CFh	EXA3	7~0	EXA3	R/W	00h	Expansion accumulator 3
D0h	PSW	7	CY	R/W	0	ALU carry flag
		6	AC	R/W	0	ALU auxiliary carry flag
		5	F0	R/W	0	General purpose user-definable flag
		4	RS1	R/W	0	Register Bank Select bit 1
		3	RS0	R/W	0	Register Bank Select bit 0
		2	OV	R/W	0	ALU overflow flag
		1	F1	R/W	0	General purpose user-definable flag
		0	P	R/W	0	Parity flag
D1h	PWM0DH	7~0	PWM0DH	R/W	00h	PWM0 duty high byte
D2h	PWM0DL	7~0	PWM0DL	R/W	00h	PWM0 duty low byte
D3h	PWM1DH	7~0	PWM1DH	R/W	00h	PWM1 duty high byte
D4h	PWM1DL	7~0	PWM1DL	R/W	00h	PWM1 duty low byte
D5h	PWM2DH	7~0	PWM2DH	R/W	00h	PWM2 duty high byte
D6h	PWM2DL	7~0	PWM2DL	R/W	00h	PWM2 duty low byte
D7h	CFGOP	4~0	OPTRIM	R/W	-	OP trimming value
D8h	CLKCON	5	STPSCK	R/W	1	Set 1 to stop Slow clock in Stop Mode.
		4	STPPCK	R/W	0	Set 1 to stop UART/Timer0/1/2 clock in Idle mode for current reducing.

Adr	SFR	Bit#	Bit Name	R/W	Rst	Description
		3	STPFCK	R/W	0	Set 1 to stop Fast clock for power saving in Slow/Idle mode. This bit can be changed only in Slow mode.
		2	SELFCK	R/W	0	System clock select. This bit can be changed only when STPFCK=0. 0: Slow clock 1: Fast clock
		1~0	CLKPSC	R/W	11	System clock prescaler. Effective after 16 clock cycles (Max.) delay. 00: System clock is Fast/Slow clock divided by 16 01: System clock is Fast/Slow clock divided by 4 10: System clock is Fast/Slow clock divided by 2 11: System clock is Fast/Slow clock divided by 1
D9h	<b>PWM0PRDH</b>	7~0	PWM0PRDH	R/W	FFh	PWM0 period high byte
DAh	<b>PWM0PRDL</b>	7~0	PWM0PRDL	R/W	FFh	PWM0 period low byte
DBh	<b>PWM1PRDH</b>	7~0	PWM1PRDH	R/W	FFh	PWM1/PWM2/PWM3/PWM4/PWM5/PWM6 period high byte
DCh	<b>PWM1PRDL</b>	7~0	PWM1PRDL	R/W	FFh	PWM1/PWM2/PWM3/PWM4/PWM5/PWM6 period low byte
DDh	<b>PWM3DH</b>	7~0	PWM3DH	R/W	00h	PWM3 duty high byte
DEh	<b>PWM3DL</b>	7~0	PWM3DL	R/W	00h	PWM3 duty low byte
DFh	<b>UARTCON</b>	7	UARTBRS	R/W	0	UART Baud Rate Source Select 0: 8051 default Baud Rate source select 1: UART Baud Rate select as UARTBRP
		6~0	UARTBRP	R/W	00h	Define UART Baud Rate Prescaler UART Baud Rate = Fsys/32/UARTBRP
E0h	<b>ACC</b>	7~0	ACC	R/W	00h	Accumulator
E1h	<b>MICON</b>	7	MIEN	R/W	0	Master I <sup>2</sup> C enable 0: disable 1: enable
		6	MIACKO	R/W	0	When Master I <sup>2</sup> C receive data, send acknowledge to I <sup>2</sup> C Bus 0: ACK to slave device 1: NACK to slave device
		5	MIIF	R/W	0	Master I <sup>2</sup> C Interrupt flag 0: write 0 to clear it 1: Master I <sup>2</sup> C transfer one byte complete
		4	MIACKI	R	-	When Master I <sup>2</sup> C transfer, acknowledgement form I <sup>2</sup> C bus (read only) 0: ACK received 1: NACK received
		3	MISTART	R/W	0	Master I <sup>2</sup> C Start bit 1: start I <sup>2</sup> C bus transfer
		2	MISTOP	R/W	1	Master I <sup>2</sup> C Stop bit 1: send STOP signal to stop I <sup>2</sup> C bus
		1~0	MICR	R/W	00	Master I <sup>2</sup> C (SCL) clock frequency selection 00: Fsys/4 (ex. If Fsys=16MHz, I <sup>2</sup> C clock is 4M Hz) 01: Fsys/16 (ex. If Fsys=16MHz, I <sup>2</sup> C clock is 1M Hz) 10: Fsys/64 (ex. If Fsys=16MHz, I <sup>2</sup> C clock is 250K Hz) 11: Fsys/256 (ex. If Fsys=16MHz, I <sup>2</sup> C clock is 62.5K Hz)
E2h	<b>MIDAT</b>	7~0	MIDAT	R/W	00	Master I <sup>2</sup> C data shift register (W): After Start and before Stop condition, write this register will resume transmission to I <sup>2</sup> C bus (R): After Start and before Stop condition, read this register will resume receiving from I <sup>2</sup> C bus

Adr	SFR	Bit#	Bit Name	R/W	Rst	Description
E3h	LVRCON	5	PORPD	R/W	0	POR Power Down. 0: POR Enable, 1: POR Disable
		4	LVRPD	R/W	0	LVR Power Down. 0: LVR Enable, 1: LVR Disable
		3~0	LVRSEL	R/W	0000	Low Voltage Reset (LVR) select. (step=0.14V) 0000: Set LVR at 2.05V 0001: Set LVR at 2.19V 0010: Set LVR at 2.33V 0011: Set LVR at 2.47V 0100: Set LVR at 2.61V 0101: Set LVR at 2.75V 0110: Set LVR at 2.89V 0111: Set LVR at 3.03V 1000: Set LVR at 3.17V 1001: Set LVR at 3.31V 1010: Set LVR at 3.45V 1011: Set LVR at 3.59V 1100: Set LVR at 3.73V 1101: Set LVR at 3.87V 1110: Set LVR at 4.01V 1111: Set LVR at 4.15V
E4h	LVDCON	7	LVDM	R/W	0	0: VCC < VLVD (LVDIF = 1 while LVDO = 1) 1: VCC > VLVD (LVDIF = 1 while LVDO = 0)
		6	LVDO	R	0	LVD real-time Output
		5	LVDHYS	R/W	0	LVD Hysteresis Enable. 0: LVD Hysteresis disable, 1: LVD Hysteresis enable
		4	LVDPD	R/W	0	LVD Power Down. 0: LVD Enable, 1: LVD Disable
		3~0	LVDSSEL	R/W	0h	Low Voltage Detect (LVD) select. (step=0.14V) 0000: Set LVD at 2.05V 0001: Set LVD at 2.19V 0010: Set LVD at 2.33V 0011: Set LVD at 2.47V 0100: Set LVD at 2.61V 0101: Set LVD at 2.75V 0110: Set LVD at 2.89V 0111: Set LVD at 3.03V 1000: Set LVD at 3.17V 1001: Set LVD at 3.31V 1010: Set LVD at 3.45V 1011: Set LVD at 3.59V 1100: Set LVD at 3.73V 1101: Set LVD at 3.87V 1110: Set LVD at 4.01V 1111: Set LVD at 4.15V
E5h	EFTCON	7	EFT2CS	R/W	0	EFT2 Detector enable 0: Disable EFT2 1: Enable EFT2
		6	EFT1CS	R/W	0	EFT1 Detector enable 0: Disable EFT1 1: Enable EFT1
		5~4	EFT1S	R/W	00	EFT1 Detector sensitivity adjustment
		3	EFTSLOW	R/W	0	Force SYSCLK to SLOWCLK while EFT detected 0: Disable 1: Enable
		2	EFTWCPU	R/W	0	CPU enter Wait state while EFT detected 0: Disable 1: Enable
		1	EFTWOUT	R/W	0	EFTWAIT output to pin 0: P3.6 = normal I/O

Adr	SFR	Bit#	Bit Name	R/W	Rst	Description
						1: P3.6 = EFTWAIT
		0	CKHLDE	R/W	0	clock hold enable 0: Disable 1: Enable
E6h	<b>EXA</b>	7~0	EXA	R/W	00h	Expansion accumulator
E7h	<b>EXB</b>	7~0	EXB	R/W	00h	Expansion B register
E9h	<b>PWM4DH</b>	7~0	PWM4DH	R/W	00h	PWM4 duty high byte
EAh	<b>PWM4DL</b>	7~0	PWM4DL	R/W	00h	PWM4 duty low byte
EBh	<b>PWM5DH</b>	7~0	PWM5DH	R/W	00h	PWM5 duty high byte
ECh	<b>PWM5DL</b>	7~0	PWM5DL	R/W	00h	PWM5 duty low byte
EDh	<b>PWM6DH</b>	7~0	PWM6DH	R/W	00h	PWM6 duty high byte
EEh	<b>PWM6DL</b>	7~0	PWM6DL	R/W	00h	PWM6 duty low byte
EFh	<b>PWRCON</b>	7	IVCPD	R/W	1	IVC(build-in VDD regulator) power down 0: IVC Enable ( $V_{DD} = V_{IC}$ 's voltage) 1: IVC Disable ( $V_{DD} = V_{CC}$ )
		6~5	IVCVS	R/W	11	IVC Voltage select 00: 1.70V 01: 1.95V 10: 2.20V 11: 2.45V (recommended)
		3	WARMTIME	R/W	0	Warm-up time for wake-up from Halt/Stop mode 0: 128 Clock 1: 64 Clock
F0h	<b>B</b>	7~0	B	R/W	00h	B register
F1h	<b>CRCDL</b>	7~0	CRCDL	R/W	FFh	16-bit CRC data bit 7~0
F2h	<b>CRCDH</b>	7~0	CRCDH	R/W	FFh	16-bit CRC data bit 15~8
F3h	<b>CRCIN</b>	7~0	CRCIN	W	-	CRC input data
F5h	<b>CFGBG</b>	4~0	BGTRIM	R/W	-	VBG trimming value
F6h	<b>CFGWL</b>	6~0	FRCTRIM	R/W	-	FRC frequency adjustment 00h: lowest frequency 7Fh: highest frequency
F7h	<b>AUX2</b>	7~6	WDTE	R/W	-	Watchdog Timer Reset control 0x: WDT disable 10: WDT enable in Fast/Slow mode, disable in Idle/Halt/Stop mode 11: WDT always enable
		5	PWRSVAV	R/W	-	Set 1 to reduce the chip's power consumption at Idle/Halt/Stop Mode.
		4	VBGOUT	R/W	0	Bandgap voltage output control 0: P3.2 as normal I/O 1: Bandgap voltage output to P3.2 pin
		3	DIV32	R/W	0	only active when MULDV16 = 1 0: instruction DIV as 16/16 bit division operation 1: instruction DIV as 32/16 bit division operation
		2~1	IAPTE	R/W	11	IAP write/EEPROM write/INFO write watchdog timer enable 00: Disable 01: wait 1.6ms trigger watchdog time-out flag 10: wait 3.1ms trigger watchdog time-out flag 11: wait 12.5ms trigger watchdog time-out flag
		0	MULDIV16	R/W	0	0: instruction MUL/DIV as 8*8, 8/8 operation 1: instruction MUL/DIV as 16*16, 16/16 or 32/16 operation

Adr	SFR	Bit#	Bit Name	R/W	Rst	Description
F8h	AUX1	7	CLRWDT	R/W	0	Set 1 to clear WDT, H/W auto clear it at next clock cycle
		6	CLRTM3	R/W	0	Set 1 to clear Timer3.
		5	-	R/W	0	Reserved
		4	ADSOC	R/W	0	ADC Start of Conversion Set 1 to start ADC conversion. Cleared by H/W at the end of conversion. S/W can also write 0 to clear this flag.
		3	CLRPWM0	R/W	1	PWM0 clear enable 0: PWM0 is running 1: PWM0 is cleared and held
		2	CLRPWM1	R/W	1	PWM1/PWM2/PWM3/PWM4/PWM5/PWM6 clear enable 0: PWM1/PWM2/PWM3/PWM4/PWM5/PWM6 is running 1: PWM1/PWM2/PWM3/PWM4/PWM5/PWM6 is cleared and held
		1	LDOCOUT	R/W	0	0: P3.7 as normal IO 1: LDOC output to P3.7 (active while XRSTE=0)
		0	DPSEL	R/W	0	Active DPTR Select

Adr	Flash	Bit#	Bit Name	Description
3FF9h	CFGOP	4~0	OPTRIM	OP adjustment.
3FFBh	CFGBG	4~0	BGTRIM	VBG adjustment. VBG is trimmed to 1.20V in chip manufacturing.
3FFDh	CFGWL	6~0	FRCTRIM	FRC frequency adjustment. FRC is trimmed to 16.588 MHz in chip manufacturing.
3FFFh	CFGWH	7	PROT	Flash Code Protect, 1=Protect
		6	XRSTE	External Pin Reset Enable, 1=Enable.
		5	-	Reserved
		4	HVS	0: ROM speed up function enable for improving write speed at high voltage 1: ROM speed up function disable
		3~2	BOOTV	Reset Vector after POR 00: Reset Vector = 0x3800, BOOT mode enable, BOOT Area Size = 2K 01: Reset Vector = 0x3000, BOOT mode enable, BOOT Area Size = 4K 1x: Reset Vector = 0x0000, BOOT mode disable, no BOOT Area.
		1~0	-	Reserved

## INSTRUCTION SET

Instructions are 1, 2 or 3 bytes long as listed in the 'byte' column below. Each instruction takes 2~32 System clock cycles to execute as listed in the 'cycle' column below.

ARITHMETIC				
Mnemonic	Description	byte	cycle	opcode
ADD A,Rn	Add register to A	1	2	28-2F
ADD A,dir	Add direct byte to A	2	2	25
ADD A,@Ri	Add indirect memory to A	1	2	26-27
ADD A,#data	Add immediate to A	2	2	24
ADDC A,Rn	Add register to A with carry	1	2	38-3F
ADDC A,dir	Add direct byte to A with carry	2	2	35
ADDC A,@Ri	Add indirect memory to A with carry	1	2	36-37
ADDC A,#data	Add immediate to A with carry	2	2	34
SUBB A,Rn	Subtract register from A with borrow	1	2	98-9F
SUBB A,dir	Subtract direct byte from A with borrow	2	2	95
SUBB A,@Ri	Subtract indirect memory from A with borrow	1	2	96-97
SUBB A,#data	Subtract immediate from A with borrow	2	2	94
INC A	Increment A	1	2	04
INC Rn	Increment register	1	2	08-0F
INC dir	Increment direct byte	2	2	05
INC @Ri	Increment indirect memory	1	2	06-07
DEC A	Decrement A	1	2	14
DEC Rn	Decrement register	1	2	18-1F
DEC dir	Decrement direct byte	2	2	15
DEC @Ri	Decrement indirect memory	1	2	16-17
INC DPTR	Increment data pointer	1	4	A3
MUL AB	Multiply A by B	1	8/16	A4
DIV AB	Divide A by B	1	8/16/32	84
DA A	Decimal Adjust A	1	2	D4

LOGICAL				
Mnemonic	Description	byte	cycle	opcode
ANL A,Rn	AND register to A	1	2	58-5F
ANL A,dir	AND direct byte to A	2	2	55
ANL A,@Ri	AND indirect memory to A	1	2	56-57
ANL A,#data	AND immediate to A	2	2	54
ANL dir,A	AND A to direct byte	2	2	52
ANL dir,#data	AND immediate to direct byte	3	4	53
ORL A,Rn	OR register to A	1	2	48-4F
ORL A,dir	OR direct byte to A	2	2	45
ORL A,@Ri	OR indirect memory to A	1	2	46-47
ORL A,#data	OR immediate to A	2	2	44
ORL dir,A	OR A to direct byte	2	2	42
ORL dir,#data	OR immediate to direct byte	3	4	43
XRL A,Rn	Exclusive-OR register to A	1	2	68-6F
XRL A,dir	Exclusive-OR direct byte to A	2	2	65
XRL A,@Ri	Exclusive-OR indirect memory to A	1	2	66-67
XRL A,#data	Exclusive-OR immediate to A	2	2	64
XRL dir,A	Exclusive-OR A to direct byte	2	2	62
XRL dir,#data	Exclusive-OR immediate to direct byte	3	4	63
CLR A	Clear A	1	2	E4
CPL A	Complement A	1	2	F4
SWAP A	Swap Nibbles of A	1	2	C4

<b>LOGICAL</b>				
<b>Mnemonic</b>	<b>Description</b>	<b>byte</b>	<b>cycle</b>	<b>opcode</b>
RL A	Rotate A left	1	2	23
RLC A	Rotate A left through carry	1	2	33
RR A	Rotate A right	1	2	03
RRC A	Rotate A right through carry	1	2	13

<b>DATA TRANSFER</b>				
<b>Mnemonic</b>	<b>Description</b>	<b>byte</b>	<b>cycle</b>	<b>opcode</b>
MOV A,Rn	Move register to A	1	2	E8-EF
MOV A,dir	Move direct byte to A	2	2	E5
MOV A,@Ri	Move indirect memory to A	1	2	E6-E7
MOV A,#data	Move immediate to A	2	2	74
MOV Rn,A	Move A to register	1	2	F8-FF
MOV Rn,dir	Move direct byte to register	2	4	A8-AF
MOV Rn,#data	Move immediate to register	2	2	78-7F
MOV dir,A	Move A to direct byte	2	2	F5
MOV dir,Rn	Move register to direct byte	2	4	88-8F
MOV dir,dir	Move direct byte to direct byte	3	4	85
MOV dir,@Ri	Move indirect memory to direct byte	2	4	86-87
MOV dir,#data	Move immediate to direct byte	3	4	75
MOV @Ri,A	Move A to indirect memory	1	2	F6-F7
MOV @Ri,dir	Move direct byte to indirect memory	2	4	A6-A7
MOV @Ri,#data	Move immediate to indirect memory	2	2	76-77
MOV DPTR,#data	Move immediate to data pointer	3	4	90
MOVC A,@A+DPTR	Move code byte relative DPTR to A	1	8	93
MOVC A,@A+PC	Move code byte relative PC to A	1	8	83
MOVX A,@Ri	Move external data(A8) to A	1	8	E2-E3
MOVX A,@DPTR	Move external data(A16) to A	1	8	E0
MOVX @Ri,A	Move A to external data(A8)	1	8	F2-F3
MOVX @DPTR,A	Move A to external data(A16)	1	8	F0
PUSH dir	Push direct byte onto stack	2	4	C0
POP dir	Pop direct byte from stack	2	4	D0
XCH A,Rn	Exchange A and register	1	2	C8-CF
XCH A,dir	Exchange A and direct byte	2	2	C5
XCH A,@Ri	Exchange A and indirect memory	1	2	C6-C7
XCHD A,@Ri	Exchange A and indirect memory nibble	1	2	D6-D7

<b>BOOLEAN</b>				
<b>Mnemonic</b>	<b>Description</b>	<b>byte</b>	<b>cycle</b>	<b>opcode</b>
CLR C	Clear carry	1	2	C3
CLR bit	Clear direct bit	2	2	C2
SETB C	Set carry	1	2	D3
SETB bit	Set direct bit	2	2	D2
CPL C	Complement carry	1	2	B3
CPL bit	Complement direct bit	2	2	B2
ANL C,bit	AND direct bit to carry	2	4	82
ANL C,/bit	AND direct bit inverse to carry	2	4	B0
ORL C,bit	OR direct bit to carry	2	4	72
ORL C,/bit	OR direct bit inverse to carry	2	4	A0
MOV C,bit	Move direct bit to carry	2	2	A2
MOV bit,C	Move carry to direct bit	2	4	92



<b>BRANCHING</b>				
<b>Mnemonic</b>	<b>Description</b>	<b>byte</b>	<b>cycle</b>	<b>Opcode</b>
ACALL addr 11	Absolute jump to subroutine	2	4 (+2)	11-F1
LCALL addr 16	Long jump to subroutine	3	4 (+2)	12
RET	Return from subroutine	1	4 (+2)	22
RETI	Return from interrupt	1	4 (+2)	32
AJMP addr 11	Absolute jump unconditional	2	4 (+2)	01-E1
LJMP addr 16	Long jump unconditional	3	4 (+2)	02
SJMP rel	Short jump (relative address)	2	4 (+2)	80
JC rel	Jump on carry = 1	2	4 (or 6)	40
JNC rel	Jump on carry = 0	2	4 (or 6)	50
JB bit,rel	Jump on direct bit = 1	3	4 (or 6)	20
JNB bit,rel	Jump on direct bit = 0	3	4 (or 6)	30
JBC bit,rel	Jump on direct bit = 1 and clear	3	4 (or 6)	10
JMP @A+DPTR	Jump indirect relative DPTR	1	4 (+2)	73
JZ rel	Jump on accumulator = 0	2	4 (or 6)	60
JNZ rel	Jump on accumulator ... 0	2	4 (or 6)	70
CJNE A,dir,rel	Compare A,direct, jump not equal relative	3	4 (or 6)	B5
CJNE A,#data,rel	Compare A,immediate, jump not equal relative	3	4 (or 6)	B4
CJNE Rn,#data,rel	Compare register,immediate, jump not equal relative	3	4 (or 6)	B8-BF
CJNE @Ri,#data,rel	Compare indirect,immediate, jump not equal relative	3	4 (or 6)	B6-B7
DJNZ Rn,rel	Decrement register, jump not zero relative	2	4 (or 6)	D8-DF
DJNZ dir,rel	Decrement direct byte, jump not zero relative	3	4 (or 6)	D5

<b>MISCELLANEOUS</b>				
<b>Mnemonic</b>	<b>Description</b>	<b>byte</b>	<b>cycle</b>	<b>opcode</b>
NOP	No operation	1	2	00

In the above table, an entry such as E8-EF indicates a continuous block of hex opcodes used for 8 different registers, the register numbers of which are defined by the lowest three bits of the corresponding code. Non-continuous blocks of codes, shown as 11-F1 (for example), are used for absolute jumps and calls with the top 3 bits of the code being used to store the top three bits of the destination address.

## ELECTRICAL CHARACTERISTICS

### 1. Absolute Maximum Ratings ( $T_A=25^\circ\text{C}$ )

Parameter	Rating	Unit
Supply voltage	$V_{SS} - 0.3 \sim V_{SS} + 5.5$	V
Input voltage	$V_{SS} - 0.3 \sim V_{CC} + 0.3$	
Output voltage	$V_{SS} - 0.3 \sim V_{CC} + 0.3$	
Output current high per all PIN	-80	mA
Output current low per all PIN	+150	
Maximum Operating Voltage	5.5	V
Operating temperature	-40 ~ +105	°C
Storage temperature	-65 ~ +150	

**2. DC Characteristics** ( $T_A=25\text{ }^\circ\text{C}$ ,  $V_{CC}=2.2\text{V} \sim 5.5\text{V}$ ) (TBD)

Parameter	Symbol	Conditions	Min	Typ	Max	Unit	
Operating Voltage	$V_{CC}$	$F_{SYS}=16.588\text{ MHz}$	2.2	–	5.5	V	
Input High Voltage	$V_{IH}$	All Input	$V_{CC}=5\text{V}$	$0.6V_{CC}$	–	–	V
			$V_{CC}=3\text{V}$	$0.6V_{CC}$	–	–	V
Input Low Voltage	$V_{IL}$	All Input	$V_{CC}=5\text{V}$	–	–	$0.2V_{CC}$	V
			$V_{CC}=3\text{V}$	–	–	$0.2V_{CC}$	V
I/O Port Source Current	$I_{OH}$	All Output	$V_{CC}=5\text{V}$ , $V_{OH}=0.9V_{CC}$	6	12	–	mA
			$V_{CC}=3\text{V}$ , $V_{OH}=0.9V_{CC}$	2.5	5	–	
I/O Port Sink Current	$I_{OL}$	All Output,	$V_{CC}=5\text{V}$ , $V_{OL}=0.1V_{CC}$	41	82	–	mA
			$V_{CC}=3\text{V}$ , $V_{OL}=0.1V_{CC}$	18	36	–	
Supply Current	$I_{DD}$	FAST mode $V_{CC}=5\text{V}$	FRC=16.588 MHz		7.3		mA
			FRC=8.294 MHz	–	6.7	–	
		FAST mode $V_{CC}=3\text{V}$	FRC=16.588 MHz	–	4.0	–	mA
			FRC=8.294 MHz		3.0		
		SLOW mode	SRC, $V_{CC}=5\text{V}$	–	2.1	–	mA
			SRC, $V_{CC}=3\text{V}$	–	1.4	–	
		FAST mode $V_{CC}=5\text{V}$ , IVC=2.45V	FRC=16.588 MHz		3.9		mA
			FRC=8.294 MHz		2.9		
		FAST mode $V_{CC}=3\text{V}$ , IVC=2.45V	FRC=16.588 MHz		3.7		mA
			FRC=8.294 MHz		2.7		
		SLOW mode IVC=2.45V	SRC, $V_{CC}=5\text{V}$		1.3		mA
			SRC, $V_{CC}=3\text{V}$		1.3		
		IDLE mode (PWRSAV=0)	SRC, $V_{CC}=5\text{V}$		138		μA
			SRC, $V_{CC}=3\text{V}$		102		
IDLE mode (PWRSAV=1)	SRC, $V_{CC}=5\text{V}$		11.8		μA		
	SRC, $V_{CC}=3\text{V}$		4.7				
IDLE mode (PWRSAV=1,PORPD=1)	SRC, $V_{CC}=5\text{V}$	–	10.8	–	μA		
	SRC, $V_{CC}=3\text{V}$		4.1				
HLAT mode (PWRSAV=1)	$V_{CC}=5\text{V}$		7.0		μA		
	$V_{CC}=3\text{V}$	–	2.4	–			
STOP mode	$V_{CC}=5\text{V}$		0.4		μA		
	$V_{CC}=3\text{V}$		0.2				
Pull-Up Resistor	$R_{UP}$	$V_{IN}=0\text{V}$ P3.7,P3.3,P1.7	$V_{CC}=5\text{V}$	–	1.16	–	MΩ
			$V_{CC}=3\text{V}$	–	1.16	–	
		$V_{IN}=0\text{V}$ other GPIO	$V_{CC}=5\text{V}$	–	31.4	–	KΩ
			$V_{CC}=3\text{V}$	–	54.0	–	

**3. Clock Timing**

Parameter	Condition	Min	Typ	Max	Unit
FRC Frequency	25°C, V <sub>CC</sub> =4.5V	-1%	16.588	+1%	MHz
	0°C ~ 105°C, V <sub>CC</sub> =4.5V	-1.5%	16.588	+1.5%	
	0°C ~ 105°C, V <sub>CC</sub> =3.0 ~ 5.5V	-3.5%	16.588	+3.5%	

Parameter	Condition	Min	Typ	Max	Unit
SRC Frequency	V <sub>CC</sub> =5V		41		KHz
	V <sub>CC</sub> =3V		37		

**4. Reset Timing Characteristics (T<sub>A</sub> = -40°C ~ +105°C)**

Parameter	Conditions	Min	Typ	Max	Unit
RESET Input Low width	Input V <sub>CC</sub> =5V ± 10 %	30	-	-	μs
WDT wakeup time	V <sub>CC</sub> =5V, WDT_PSC=11	-	50	-	ms
	V <sub>CC</sub> =3V, WDT_PSC=11	-	55	-	
CPU start up time	V <sub>CC</sub> = 5V	-	22	-	ms

**5. LVR Circuit Characteristics (T<sub>A</sub> = 25°C)**

Parameter	Symbol	Condition	Min	Typ	Max	Unit
LVR Voltage	LVR <sub>th</sub>	T <sub>A</sub> = 25°C	-	2.05	-	V
			-	2.19	-	
			-	2.33	-	
			-	2.47	-	
			-	2.61	-	
			-	2.75	-	
			-	2.89	-	
			-	3.03	-	
			-	3.17	-	
			-	3.31	-	
			-	3.45	-	
			-	3.59	-	
			-	3.73	-	
			-	3.87	-	
-	4.01	-				
-	4.15	-				
LVR Hysteresis Window	V <sub>HYS_LVR</sub>	T <sub>A</sub> = 25°C	-	20	-	mV
Low Voltage Detection time	T <sub>LVR</sub>	T <sub>A</sub> = 25°C	100	-	-	μs

**6. LVD Circuit Characteristics ( $T_A = 25^\circ\text{C}$ )**

Parameter	Symbol	Condition	Min	Typ	Max	Unit
LVD Voltage	LVD <sub>th</sub>	$T_A = 25^\circ\text{C}$	–	2.05	–	V
			–	2.19	–	
			–	2.33	–	
			–	2.47	–	
			–	2.61	–	
			–	2.75	–	
			–	2.89	–	
			–	3.03	–	
			–	3.17	–	
			–	3.31	–	
			–	3.45	–	
			–	3.59	–	
			–	3.73	–	
			–	3.87	–	
–	4.01	–				
–	4.15	–				
LVD Hysteresis Window	V <sub>HYS_LVD</sub>	LVDHYS = 0	–	20	–	mV
		LVDHYS = 1	–	60	–	
Low Voltage Detection time	T <sub>LVD</sub>	$T_A = 25^\circ\text{C}$	100	–	–	μs

**7. ADC Electrical Characteristics ( $T_A = 25^\circ\text{C}$ ,  $V_{CC} = 3.0\text{V} \sim 5.5\text{V}$ ,  $V_{SS} = 0\text{V}$ )**

Parameter	Conditions		Min	Typ	Max	Unit	
Total Accuracy	$V_{CC}=5.12\text{V}$ , $V_{SS}=0\text{V}$		–	±2.5	±4	LSB	
Integral Non-Linearity			–	±3.2	±5		
Max Input Clock ( $f_{\text{ADC}}$ )	Source impedance ( $R_s < 5\text{K}\Omega$ )		–	–	4.2	MHz	
	Source impedance ( $R_s < 10\text{K}\Omega$ )		–	–	2.1		
	Source impedance ( $R_s < 25\text{K}\Omega$ )		–	–	1.1		
	Source is VBG (ADCHS=01100b)		–	–	4.2		
Conversion Time	$F_{\text{ADC}} = 1\text{MHz}$		–	50	–	μs	
Bandgap Reference Voltage ( $V_{\text{BG}}$ )	–	$V_{CC}=2.5\text{V}\sim 5.5\text{V}$ $25^\circ\text{C}$	-1.5%	1.20	+1.5%	V	
		$V_{CC}=2.5\text{V}\sim 5.5\text{V}$ $-40^\circ\text{C}\sim 105^\circ\text{C}$	-1.8%	1.20	+1.8%		
ADC Reference Voltage ( $V_{\text{ADC}}$ )	ADCVREFS=1	$V_{CC}=3\text{V}\sim 5.5\text{V}$ $25^\circ\text{C}$	-1.7%	2.49	+1.7%		
		$V_{CC}=2.8\text{V}\sim 5.5\text{V}$ $-40^\circ\text{C}\sim 105^\circ\text{C}$	-2.3%	2.49	+2.3%		
$V_{CC}/4$ Reference Voltage ( $V_{1/4}$ )	–	$V_{CC}=5\text{V}$ , $25^\circ\text{C}$	-0.8%	1.252	+0.8%		
		$V_{CC}=3.6\text{V}$ , $25^\circ\text{C}$	-0.8%	0.902	+0.8%		
Input Voltage	–		$V_{SS}$	–	$V_{CC}$		V

**8. OPA Electrical Characteristics ( $T_A = 25^\circ\text{C}$ ,  $V_{CC} = 5\text{V}$ ,  $V_{SS} = 0\text{V}$ )**

Parameter	Conditions	Min	Typ	Max	Units
Power supply $V_{CC}$	–	2.2	–	5.5	V
$V_{icm}$	–	0	–	$V_{CC}-0.7$	V
$V_{os2}$	After trim	–	2	–	mV
$\Delta V_{os}/\Delta T$	After trim	–	4	8	$\mu\text{V}/\text{C}$
AVOL	$R_L = 1\text{M ohm}$ , $C_L = 100\text{ pF}$ , $V_i = 0.1\text{ to }4\text{V}$ , $V_o = 1\text{ to }4\text{V}$	–	100	–	dB
GBW	$R_L = 1\text{M ohm}$ , $C_L = 100\text{ pF}$	–	2	–	MHz
CMRR	$V_o = 2\text{V}$	–	80	–	dB
PSRR	$V_o = 2\text{V}$	–	80	–	dB
ICC	Gain = 1, OPP = 5V, OPO>2.5V at $V_{CC} = 5\text{V}$	–	200	–	$\mu\text{A}$
SR	No load	–	1.2	–	V/usec
IOH	Gain = 1, OPP = 5V, OPO>2.5V at $V_{CC} = 5\text{V}$	–	8	–	mA
IOL	Gain = 1, OPP = 5V, OPO>2.5V at $V_{CC} = 5\text{V}$	–	14	–	mA

**9. Comparator Characteristics ( $T_A = 25^\circ\text{C}$ ,  $V_{CC} = 3.0\text{V to }5.5\text{V}$ ,  $V_{SS} = 0\text{V}$ )**

Parameter	Conditions	Min	Typ	Max	Units
Power supply $V_{CC}$	–	2.2	–	5.5	V
Quiescent Current	$V_{CC} = 5.0\text{V}$	–	100	–	$\mu\text{A}$
DAC Current	$V_{CC} = 5.0\text{V}$	60	–	220	$\mu\text{A}$
$V_{OS\_CMP}$	$V_{CC} = 5.0\text{V}$	-15	–	15	mV
$V_{CM\_CMP}$	$V_{CC} = 5.0\text{V}$	0	–	$V_{CC}-0.5$	V
$V_{HYS\_CMP}$	$V_{CC} = 5.0\text{V}$	20	30	40	mV

**10. EEPROM Characteristics**

Parameter	Conditions	Min	Typ	Max	Unit
Write Voltage	$-20^\circ\text{C} \sim 85^\circ\text{C}$ , $IVCPD=1$	3.5	5	5.5	V
	$0^\circ\text{C} \sim 105^\circ\text{C}$ , $IVCPD=1$	4.5	5	5.5	
Write Endurance*	$V_{CC}=5\text{V}$ , $-20^\circ\text{C}$	30K	–	–	cycles
	$V_{CC}=5\text{V}$ , $-10^\circ\text{C}$	50K	–	–	
	$V_{CC}=3.5\text{V} \sim 5\text{V}$ , $85^\circ\text{C}$	50K	–	–	
	$V_{CC}=4.5\text{V}$ , $0^\circ\text{C} \sim 105^\circ\text{C}$	50K	–	–	

Note: The value of this parameter is based on the characteristics of tested samples.

### 11. Characteristic Graphs

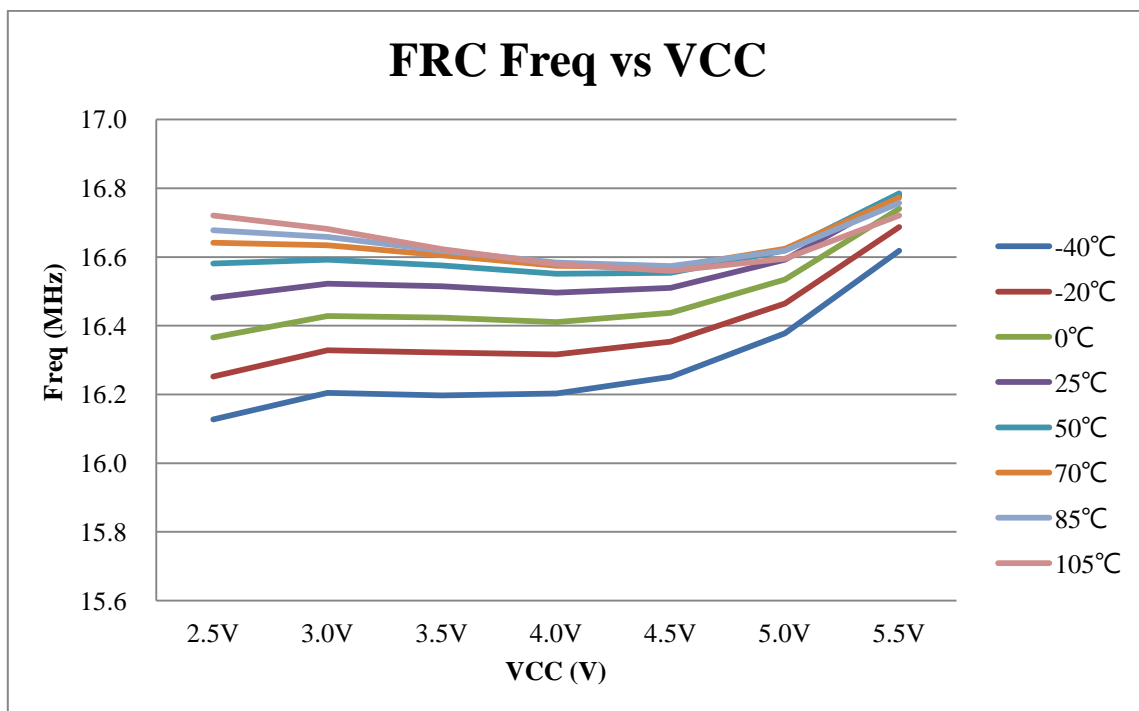
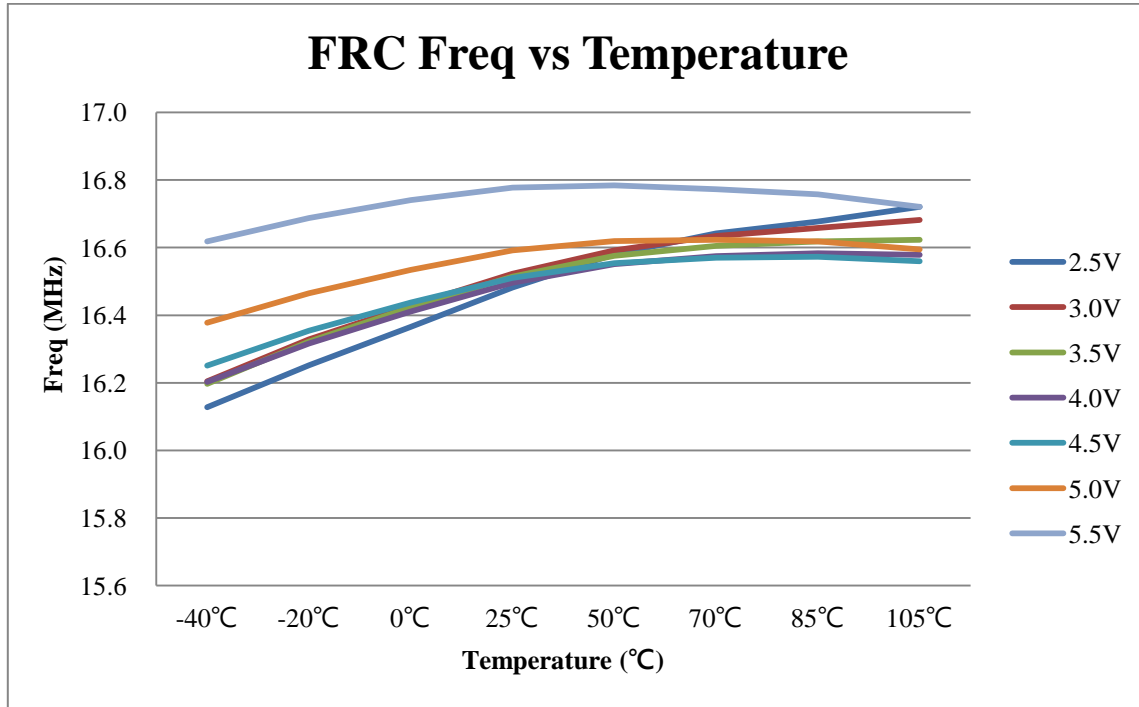

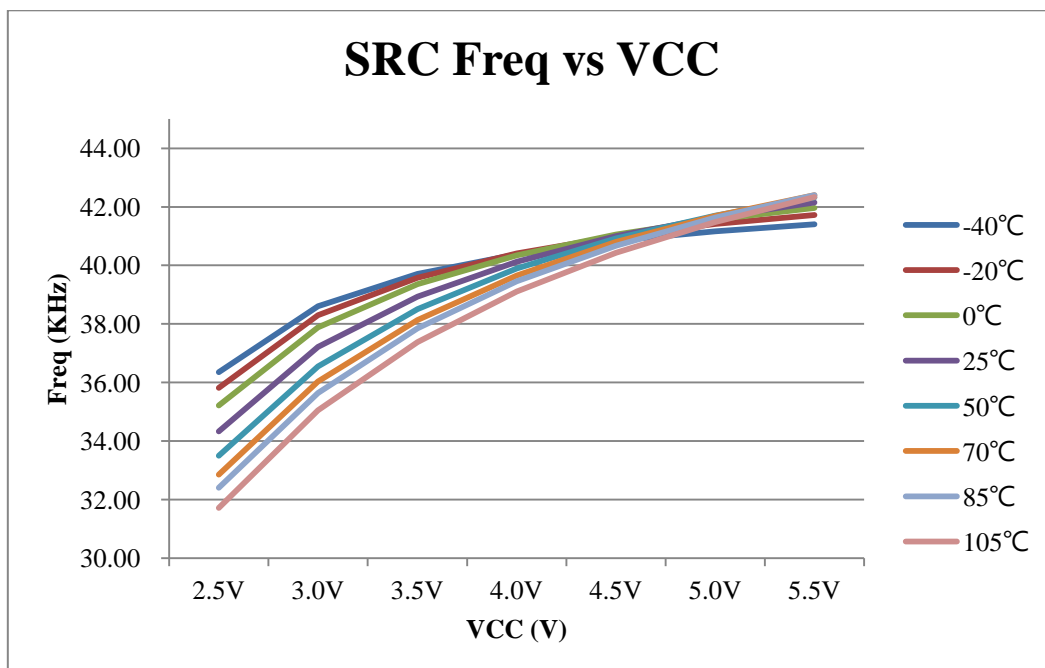
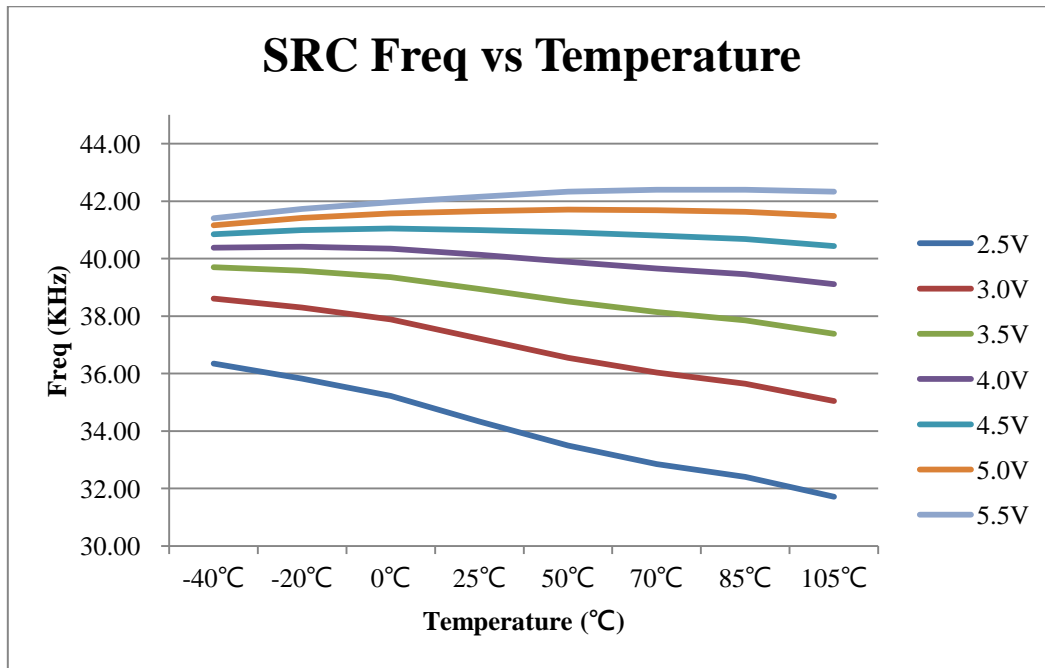



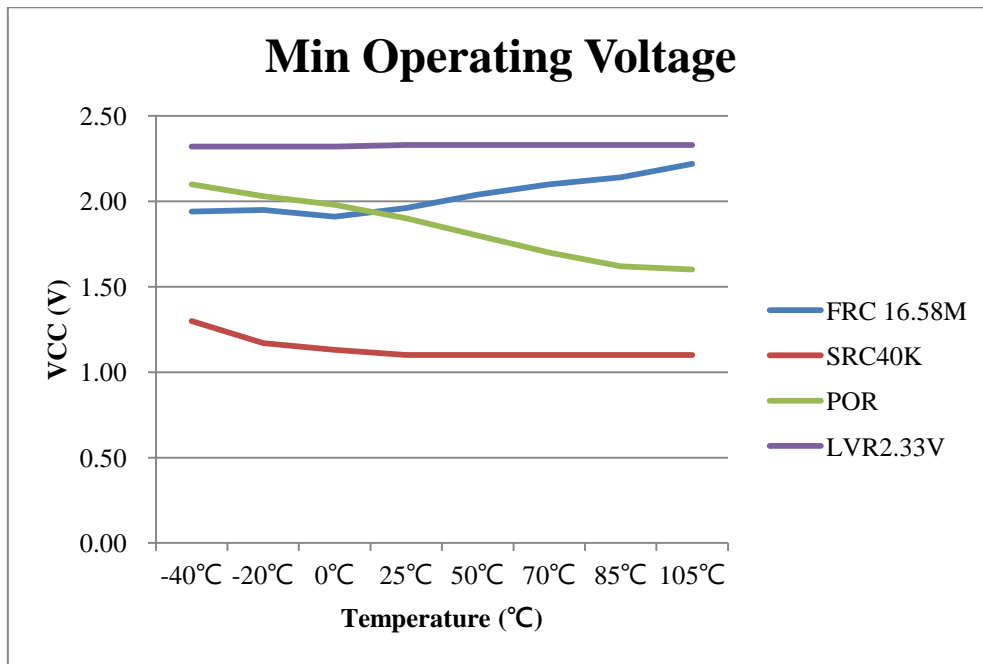

\*POR: Power on reset. VCC should greater than POR when power on. Due to the variation of the manufacturing process, the POR value will be slightly different between different chips.

\*There are 16 levels of LVR to choose from by setting CFGWH

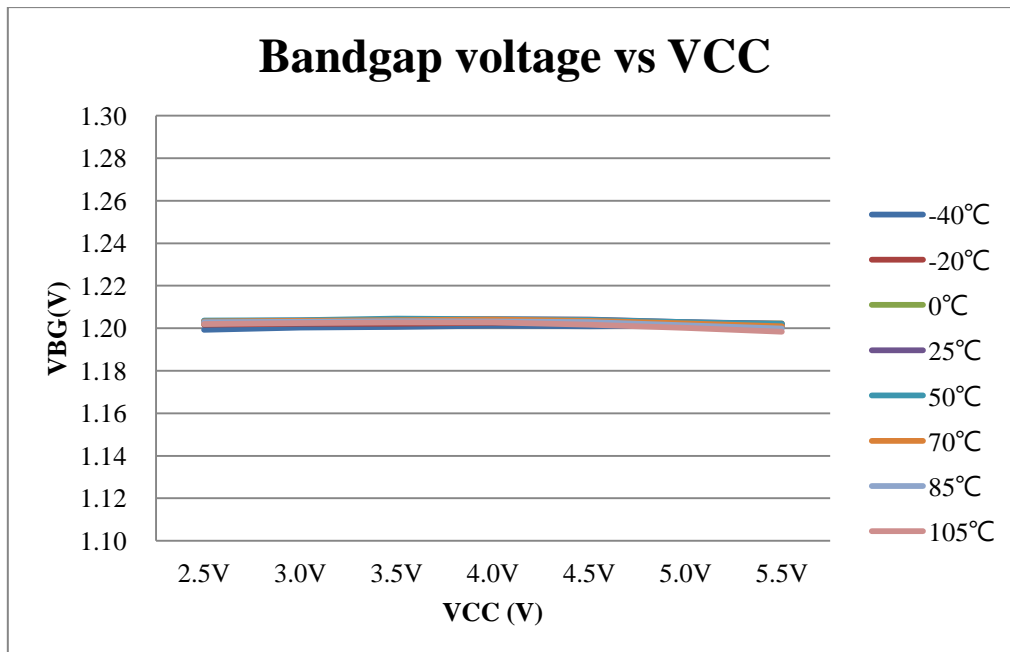

## Package and Dice Information

Please note that the package information provided is for reference only. Since this information is frequently updated, users can contact Sales to consult the latest package information and stocks.

### Ordering information

Ordering number	Package
TM52F1364-MTP	Wafer/Dice blank chip
TM52F1364-COD	Wafer/Dice with code
TM52F1364-MTP-53	MSOP 10-pin (118mil)
TM52F1364-MTP-16	SOP-16 (150mil)
TM52F1364-MTP-46	TSSOP-20 ( 173mil )
TM52F1364-MTP-21	SOP-20 ( 300mil )
TM52F1364-MTP-28	SSOP-24 ( 150mil )
TM52F1364-MTP-23	SOP-28 ( 300mil )
TM52F1364-MTP-29	SSOP-28 ( 150mil )
TM52F1364-MTP-D1	QFN-20 (3*3*0.75-0.4mm)(L=0.25mm)
TM52F1364-MTP-C3	QFN-28 (4x4x0.75-0.4mm)

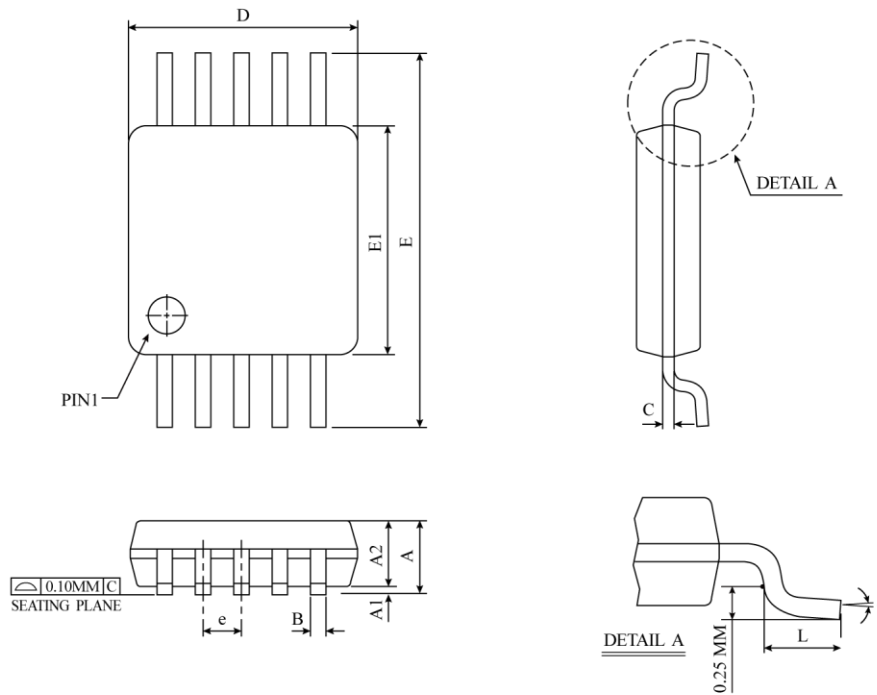
**MSOP-10 (118mil) Package Dimension**

SYMBOL	DIMENSION IN MM			DIMENSION IN INCH		
	MIN	NOM	MAX	MIN	NOM	MAX
A	0.81	0.96	1.10	0.032	0.038	0.043
A1	0.05	0.10	0.15	0.002	0.004	0.006
A2	0.75	0.85	0.95	0.030	0.034	0.037
B	0.17	0.22	0.27	0.007	0.009	0.011
C	0.13	0.18	0.23	0.005	0.007	0.009
D	2.90	3.00	3.10	0.114	0.118	0.122
E	4.75	4.90	5.05	0.187	0.193	0.199
E1	2.90	3.00	3.10	0.114	0.118	0.122
e	0.50 BSC			0.020 BSC		
L	0.40	0.55	0.70	0.016	0.022	0.028
$\theta$	0°	3°	6°	0°	3°	6°
JEDEC						

▲ \* NOTES : DIMENSION "D" DOES NOT INCLUDE MOLD PROTRUSIONS OR GATE BURRS.  
 MOLD PROTRUSIONS AND GATE BURRS SHALL NOT EXCEED 0.12 MM (0.005 INCH) PER SIDE.  
 DIMENSION "E1" DOES NOT INCLUDE MOLD PROTRUSIONS  
 MOLD PROTRUSIONS SHALL NOT EXCEED 0.25 MM (0.010 INCH) PER SIDE.

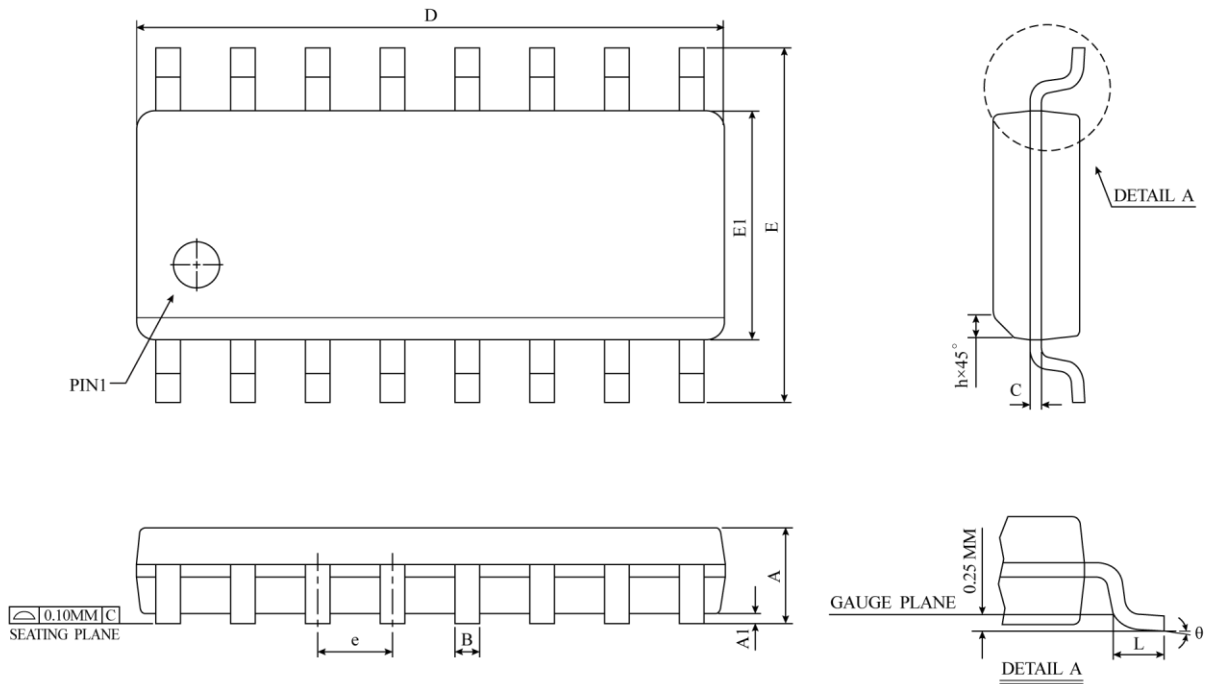
**SOP-16 ( 150mil ) Package Dimension**

SYMBOL	DIMENSION IN MM			DIMENSION IN INCH		
	MIN	NOM	MAX	MIN	NOM	MAX
A	1.35	1.55	1.75	0.0532	0.0610	0.0688
A1	0.10	0.18	0.25	0.0040	0.0069	0.0098
B	0.33	0.42	0.51	0.0130	0.0165	0.0200
C	0.19	0.22	0.25	0.0075	0.0087	0.0098
D	9.80	9.90	10.00	0.3859	0.3898	0.3937
E	5.80	6.00	6.20	0.2284	0.2362	0.2440
E1	3.80	3.90	4.00	0.1497	0.1536	0.1574
e	1.27 BSC			0.050 BSC		
h	0.25	0.38	0.50	0.0099	0.0148	0.0196
L	0.40	0.84	1.27	0.0160	0.0330	0.0500
$\theta$	$0^\circ$	$4^\circ$	$8^\circ$	$0^\circ$	$4^\circ$	$8^\circ$
JEDEC	MS-012 (AC)					

△ \*NOTES : DIMENSION "D" DOES NOT INCLUDE MOLD FLASH, PROTRUSIONS OR GATE BURRS.  
MOLD FLASH, PROTRUSIONS AND GATE BURRS SHALL  
NOT EXCEED 0.15 MM ( 0.006 INCH ) PER SIDE.

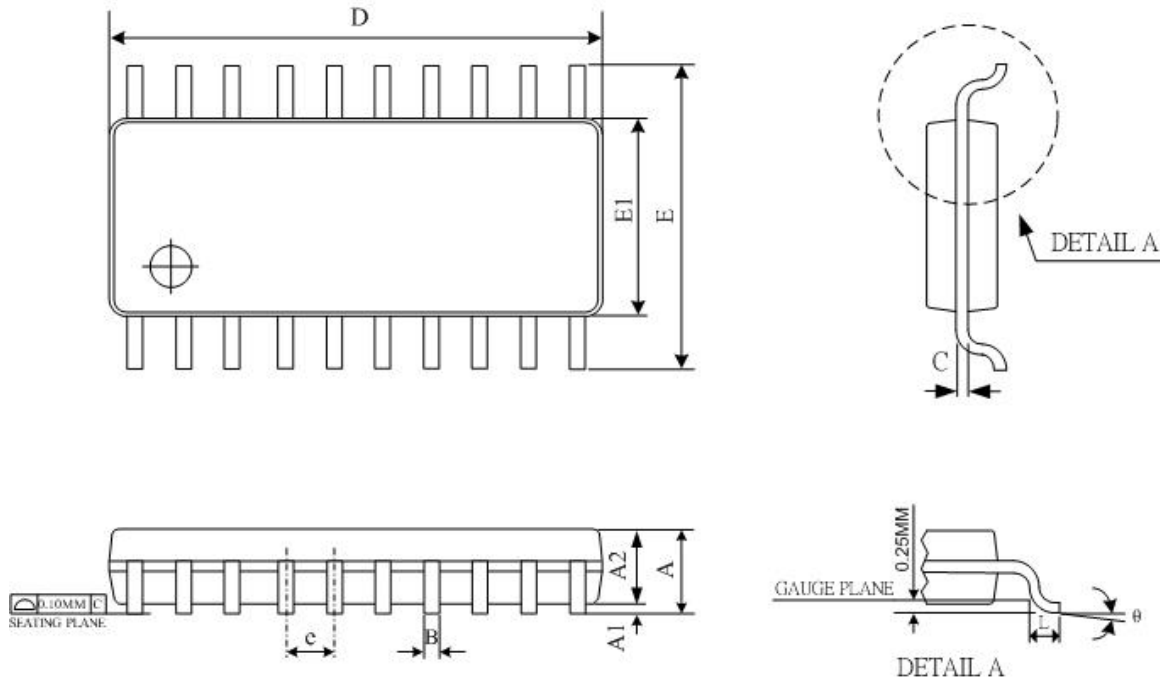
**TSSOP-20 ( 173mil ) Package Dimension**

SYMBOL	DIMENSION IN MM			DIMENSION IN INCH		
	MIN	NOM	MAX	MIN	NOM	MAX
A	-	-	1.2	-	-	0.047
A1	0.05	0.10	0.15	0.002	0.004	0.006
A2	0.8	0.93	1.05	0.031	0.036	0.041
B	0.19	-	0.3	0.007	-	0.012
D	6.4	6.5	6.6	0.252	0.256	0.260
E	6.25	6.4	6.55	0.246	0.252	0.258
E1	4.3	4.4	4.5	0.169	0.173	0.177
e	0.65 BSC			0.026 BSC		
L	0.45	0.60	0.75	0.018	0.024	0.030
θ	0 °		8 °	0 °		8 °
JEDEC	MO-153 AC REV.F					

**Notes :**

- 1.DIMENSION "D" DOES NOT INCLUDE MOLD FLASH, PROTRUSIONS OR GATE BURRS. MOLD FLASH, PROTRUSIONS OR GATE BURRS SHALL NOT EXCEED 0.15 PER SIDE.
- 2.DIMENSION "E1" DOES NOT INCLUDE INTERLEAD FLASH OR PROTRUSION. INTERLEAD FLASH OR PROTRUSION SHALL NOT EXCEED 0.25 PER SIDE.
- 3.DIMENSION "B" DOES NOT INCLUDE DAMBAR PROTRUSION.ALLOWABLE DAMBAR PROTRUSION SHALL BE 0.08MM TOTAL IN EXCESS OF THE "B" DIMENSION AT MAXIMUM METERIAL CONDITION. DAMBAR CANNOT BE LOCATED ON THE LOWER RADIUS OF THE FOOT. MINIMUM SPACE BETWEEN PROTRUSION AND ADJACENT LEAD IS 0.07MM.

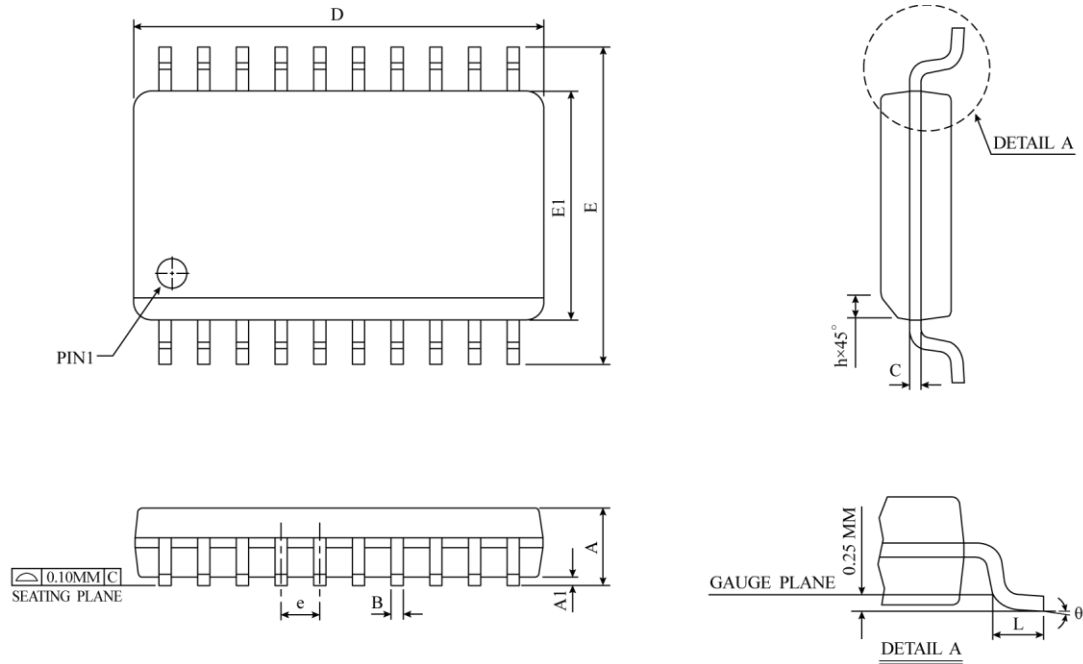
**SOP-20 ( 300mil ) Package Dimension**

SYMBOL	DIMENSION IN MM			DIMENSION IN INCH		
	MIN	NOM	MAX	MIN	NOM	MAX
A	2.35	2.50	2.65	0.0926	0.0985	0.1043
A1	0.10	0.20	0.30	0.0040	0.0079	0.0118
B	0.33	0.42	0.51	0.0130	0.0165	0.0200
C	0.23	0.28	0.32	0.0091	0.0108	0.0125
D	12.60	12.80	13.00	0.4961	0.5040	0.5118
E	10.00	10.33	10.65	0.3940	0.4425	0.4910
E1	7.40	7.50	7.60	0.2914	0.2953	0.2992
e	1.27 BSC			0.050 BSC		
h	0.25	0.50	0.75	0.0100	0.0195	0.0290
L	0.40	0.84	1.27	0.0160	0.0330	0.0500
θ	0°	4°	8°	0°	4°	8°
JEDEC	MS-013 (AC)					

⚠ \* NOTES : DIMENSION " D " DOES NOT INCLUDE MOLD FLASH, PROTRUSIONS OR GATE BURRS.  
MOLD FLASH, PROTRUSIONS AND GATE BURRS SHALL NOT EXCEED 0.15 MM ( 0.006 INCH ) PER SIDE.

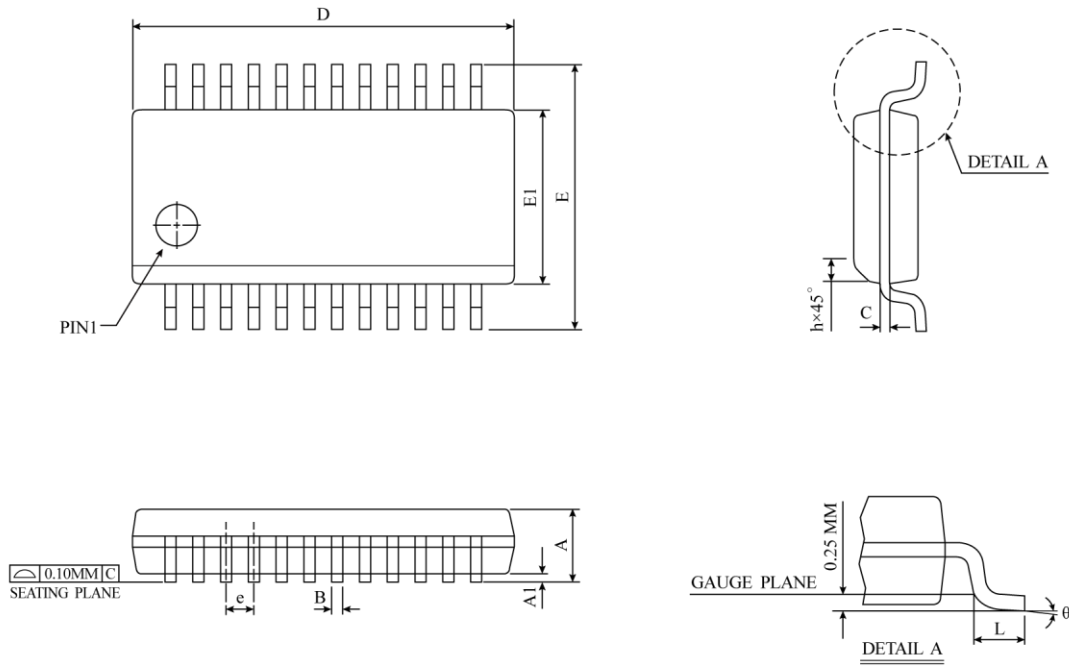
**SSOP-24 ( 150mil ) Package Dimension**

SYMBOL	DIMENSION IN MM			DIMENSION IN INCH		
	MIN	NOM	MAX	MIN	NOM	MAX
A	1.35	1.55	1.75	0.053	0.061	0.069
A1	0.10	0.18	0.25	0.004	0.007	0.010
A2	-	-	1.50	-	-	0.059
B	0.20	0.25	0.30	0.008	0.010	0.012
C	0.18	0.22	0.25	0.007	0.009	0.010
D	8.56	8.65	8.74	0.337	0.341	0.344
E	5.79	6.00	6.20	0.228	0.236	0.244
E1	3.81	3.90	3.99	0.150	0.154	0.157
e	0.635 BSC			0.025 BSC		
L	0.41	0.84	1.27	0.016	0.033	0.050
θ	0°	4°	8°	0°	4°	8°
JEDEC	M0-137 (AE)					

△ \* NOTES : DIMENSION " D " DOES NOT INCLUDE MOLD PROTRUSIONS OR GAT BURRS.  
 MOLD PROTRUSIONS AND GATE BURRS SHALL NOT EXCEED 0.006 INCH PER SIDE.

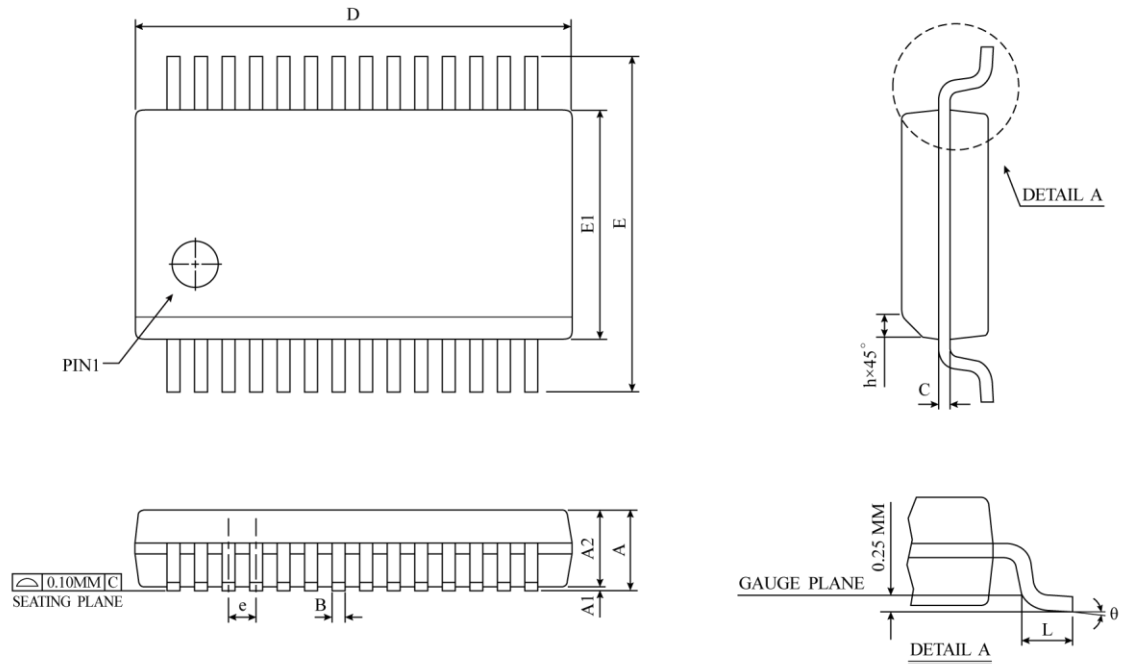
**SSOP-28 ( 150mil ) Package Dimension**

SYMBOL	DIMENSION IN MM			DIMENSION IN INCH		
	MIN	NOM	MAX	MIN	NOM	MAX
A	1.50	1.65	1.80	0.06	0.06	0.07
A1	0.102	0.176	0.249	0.004	0.007	0.010
A2	1.40	1.475	1.55	0.06	0.06	0.06
B	0.20	0.25	0.30	0.01	0.01	0.01
C	0.2TYP			0.008TYP		
e	0.635TYP			0.025TYP		
D	9.804	9.881	9.957	0.386	0.389	0.392
E	5.842	6.020	6.198	0.230	0.237	0.244
E1	3.86	3.929	3.998	0.152	0.155	0.157
L	0.406	0.648	0.889	0.016	0.026	0.035
θ	0°	4°	8°	0°	4°	8°
JEDEC	M0-137(AF)					

△\*NOTES: DIMENSION "D" DOES NOT INCLUDE MOLD PROTRUSIONS OR GATE BURRS.  
MOLD PROTRUSIONS AND GATE BURRS SHALL NOT EXCEED 0.006 INCH PER SIDE.

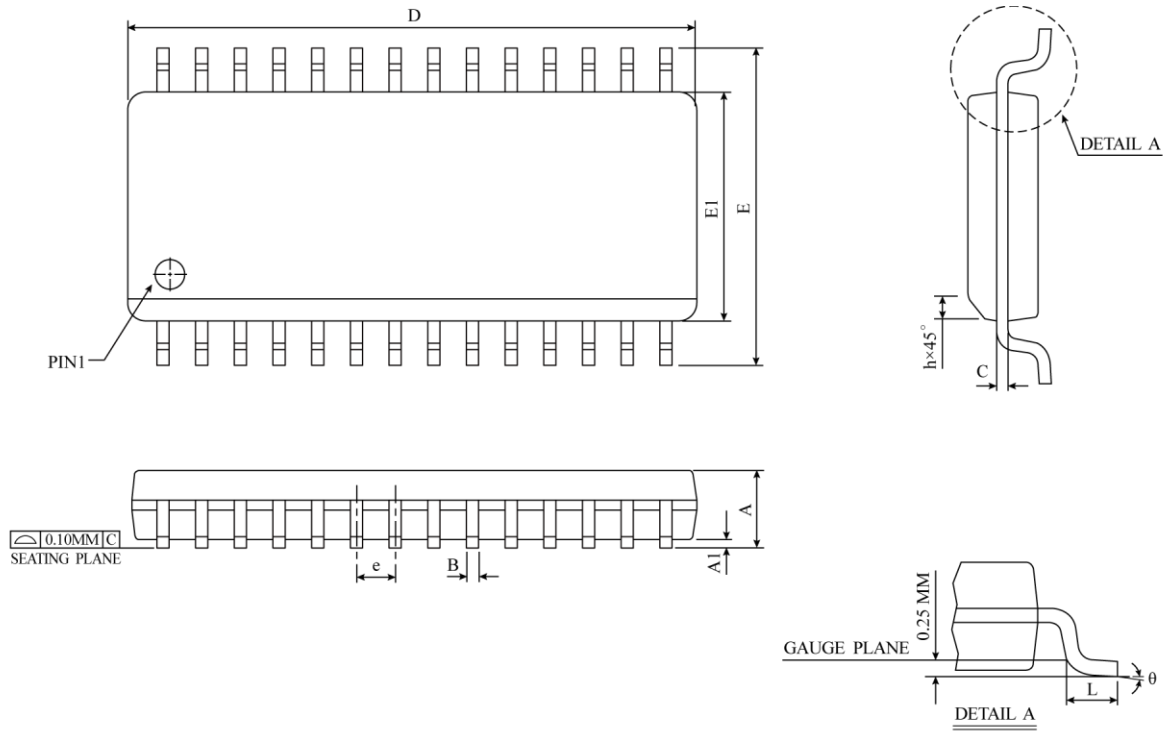

**SOP-28 ( 300mil ) Package Dimension**

SYMBOL	DIMENSION IN MM			DIMENSION IN INCH		
	MIN	NOM	MAX	MIN	NOM	MAX
A	2.35	2.50	2.65	0.0926	0.0985	0.1043
A1	0.10	0.20	0.30	0.0040	0.0079	0.0118
B	0.33	0.42	0.51	0.0130	0.0165	0.0200
C	0.23	0.28	0.32	0.0091	0.0108	0.0125
D	17.70	17.90	18.10	0.6969	0.7047	0.7125
E	10.00	10.33	10.65	0.3940	0.4425	0.4910
E1	7.40	7.50	7.60	0.2914	0.2953	0.2992
e	1.27 BSC			0.050 BSC		
h	0.25	0.50	0.75	0.0100	0.0195	0.0290
L	0.40	0.84	1.27	0.0160	0.0330	0.0500
θ	0°	4°	8°	0°	4°	8°
JEDEC	MS-013 (AE)					

△ \* NOTES : DIMENSION "D" DOES NOT INCLUDE MOLD FLASH, PROTRUSIONS OR GATE BURRS.  
MOLD FLASH, PROTRUSIONS AND GATE BURRS SHALL NOT EXCEED 0.15 MM ( 0.006 INCH ) PER SIDE.

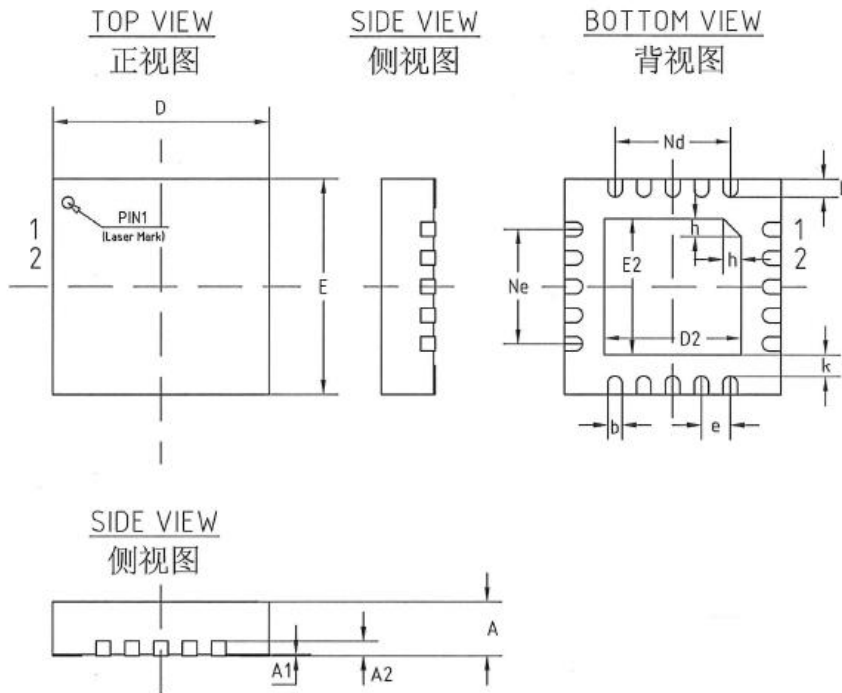
**QFN 20 (3\*3\*0.75-0.4mm) (L=0.25mm) Package Dimension**

机械尺寸/mm			
字符 SYMBOL	最小值 MIN	典型值 NOMINAL	最大值 MAX
A	0.70	0.75	0.80
A1	-	0.02	0.05
A2	0.203 REF		
b	0.15	0.20	0.25
D	2.90	3.00	3.10
D2	1.80	1.90	2.00
E	2.90	3.00	3.10
E2	1.80	1.90	2.00
e	0.40 BSC		
K	0.20	0.30	0.40
L	0.20	0.25	0.30
h	0.20	0.25	0.30
Ne	1.60 BSC		
Nd	1.60 BSC		

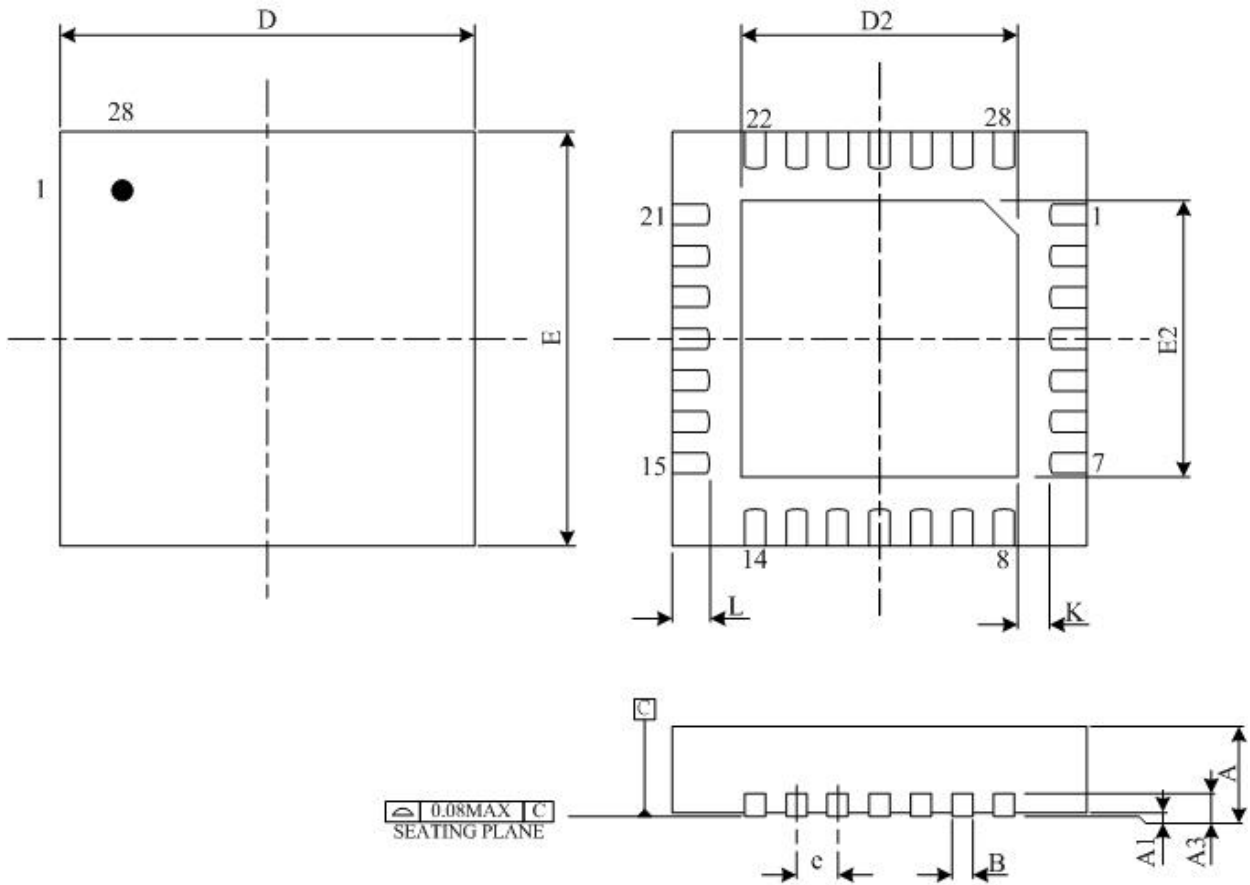
**QFN-28 (4x4x0.75-0.4mm) Package Dimension**

SYMBOL	DIMENSION IN MM			DIMENSION IN INCH		
	MIN	NOM	MAX	MIN	NOM	MAX
A	0.7	0.75	0.8	0.028	0.030	0.031
A1	0	0.02	0.05	0	0.001	0.002
A3	0.203 REF			0.008 REF		
B	0.15	0.2	0.25	0.006	0.008	0.010
D	4 BSC			0.157		
E	4 BSC			0.157		
D2	2.2	2.3	2.4	0.087	0.091	0.094
E2	2.2	2.3	2.4	0.087	0.091	0.094
e	0.4 BSC			0.016		
L	0.3	0.4	0.5	0.012	0.016	0.020
K	0.45 REF			0.018		
JEDEC	MO-220					