



十速

# **TM52F5264B/64C/ 68B/68C**

## ***DATA SHEET***

***Rev 0.94***

**tenx** reserves the right to change or discontinue the manual and online documentation to this product herein to improve reliability, function or design without further notice. **tenx** does not assume any liability arising out of the application or use of any product or circuit described herein; neither does it convey any license under its patent rights nor the rights of others. **tenx** products are not designed, intended, or authorized for use in life support appliances, devices, or systems. If Buyer purchases or uses **tenx** products for any such unintended or unauthorized application, Buyer shall indemnify and hold **tenx** and its officers, employees, subsidiaries, affiliates and distributors harmless against all claims, cost, damages, and expenses, and reasonable attorney fees arising out of, directly or indirectly, any claim of personal injury or death associated with such unintended or unauthorized use even if such claim alleges that **tenx** was negligent regarding the design or manufacture of the part.

---

## AMENDMENT HISTORY

Version	Date	Description
V0.90	Jan, 2017	New release.
V0.91	Feb, 2017	Remove package DIP 24
V0.92	Mar, 2017	Add TM52F5264B/68B DC Characteristics
V0.93	Aug, 2017	<ol style="list-style-type: none"><li>1. FRC accuracy &amp; Temp. curve</li><li>2. Add Tiny current description</li><li>3. Modify SPI Block diagram</li><li>4. Modify TK CLD dis-charge Time</li><li>5. Other detail</li></ol>
V0.94	Jun, 2018	<ol style="list-style-type: none"><li>1. Add package SSOP 20/ SSOP 24</li><li>2. Add operating voltage vs. temperature characteristics graphs</li></ol>

# CONTENTS

<b>AMENDMENT HISTORY</b> .....	<b>2</b>
<b>TM52<sub>Series</sub> F52<sub>xx</sub> FAMILY</b> .....	<b>5</b>
<b>GENERAL DESCRIPTION</b> .....	<b>6</b>
<b>BLOCK DIAGRAM</b> .....	<b>6</b>
<b>FEATURES</b> .....	<b>7</b>
<b>PIN ASSIGNMENT</b> .....	<b>10</b>
<b>PIN DESCRIPTION</b> .....	<b>12</b>
<b>PIN SUMMARY</b> .....	<b>13</b>
<b>FUNCTIONAL DESCRIPTION</b> .....	<b>15</b>
1. CPU Core .....	15
1.1 Accumulator (ACC).....	15
1.2 B Register (B).....	15
1.3 Stack Pointer (SP).....	16
1.4 Dual Data Pointer (DPTRs).....	16
1.5 Program Status Word (PSW).....	17
2. Memory.....	18
2.1 Program Memory.....	18
2.2 Data Memory.....	21
3. Power .....	23
4. Reset.....	25
4.1 Power on Reset .....	25
4.2 External Pin Reset.....	25
4.3 Software Command Reset .....	25
4.4 Watchdog Timer Reset .....	25
4.5 Low Voltage Reset .....	25
5. Clock Circuitry and Operation Mode .....	27
5.1 System Clock.....	27
5.2 Operation Mode .....	28
6. Interrupt and Wake-up .....	29
6.1 Interrupt Enable and Priority Control .....	29
6.2 Pin Interrupt .....	32
6.3 Idle Mode Wake up and Interrupt.....	33
6.4 Stop Mode Wake up and Interrupt.....	33
7. I/O Ports .....	35
7.1 Port1 & P2.1~P2.0 & P3.6~P3.0 .....	35
7.2 P3.7 .....	42

7.3 P0.3~P0.0.....	42
8. Timers .....	44
8.1 Timer0/1 .....	44
8.2 Timer2.....	45
8.3 Timer3.....	47
8.4 T0O and T2O Output Control .....	48
9. UART.....	49
10. PWMs .....	51
11. ADC .....	54
11.1 ADC Channels .....	55
11.2 ADC Conversion Time .....	55
12. Touch Key (F5268 Only).....	58
13. Serial Peripheral Interface (SPI) .....	62
14. In Circuit Emulation (ICE) Mode .....	67
<b>SFR &amp; CFGW MAP .....</b>	<b>68</b>
<b>cSFR &amp; CFGW DESCRIPTION.....</b>	<b>70</b>
<b>INSTRUCTION SET .....</b>	<b>82</b>
<b>ELECTRICAL CHARACTERISTICS .....</b>	<b>85</b>
1. Absolute Maximum Ratings .....	85
2. DC Characteristics .....	85
3. Clock Timing .....	88
4. Reset Timing Characteristics .....	88
5. ADC Electrical Characteristics .....	88
6. Characteristics Graphs .....	89
<b>PACKAGE INFORMATION .....</b>	<b>92</b>

**TM52<sub>Series</sub> F52xx FAMILY**
**Common Features**

CPU	MTP/Flash Program Memory	RAM Bytes	Dual Clock	Operation Mode	Timer0 Timer1 Timer2	UART	Real-time Timer3	LVD	LVR
Fast 8051 (2T)	4K~16K With IAP, ISP, ICP	256 ~ 512	SXT SRC FXT FRC	Fast Slow Idle Stop	8051 Standard		15-bit	2.3V	1.8V 2.3V 2.9V

**Note:** IAP, ISP only for Flash type program memory

**Family Members Features**

P/N	Program Memory	RAM Bytes	IO Pin	PWM	SAR ADC	Touch Key	LCD	LED	SPI	Others
TM52-M5254	MTP	256	18	(8+2)-bit x2	12-bit 12-ch	–	–	–	–	–
TM52-M5258	4K Bytes					14-ch				
TM52-F5264	Flash	256	22	(8+2)-bit x2	12-bit 12-ch	–	–	–	Yes	–
TM52-F5268	8K Bytes					14-ch				
TM52-F5274	Flash	512	30	(8+2)-bit x2	12-bit 12-ch	–	4x18	4x18	Yes	–
TM52-F5278	8K Bytes					14-ch				
TM52-F5273	Flash	768	30	(8+2)-bit x2	12-bit 12-ch	–	4x20	8x16	Yes	–
TM52-F5276	16K Bytes					16-ch				
TM52-F5288	Flash	512	42	(8+2)-bit x2	12-bit 12-ch	–	8x20	8x20	Yes	–
TM52-F5284	16K Bytes					12-ch				

P/N	Operation Voltage	Operation Current (V <sub>CC</sub> =3V) MODE3V=1, PWRSAV=1, LVR Disable				Max. System Clock (Hz)			
		Fast FRC	Slow SRC	Idle SRC	Stop	SXT	SRC	FXT	FRC
TM52-M5254	1.9~5.5V	2.0mA	21μA	5.2μA	<0.1μA	32K	80K	6M	7.37M
TM52-M5258									
TM52-F5264B	1.8~5.5V	2.5mA	9μA	3μA	<0.1μA	32K	24K	8M	7.37M
TM52-F5268B									
TM52-F5264C	2.0~5.5V	2.5mA	12μA	6μA	3μA	32K	24K	8M	7.37M
TM52-F5268C									
TM52-F5274C	2.0~5.5V	2.5mA	12μA	6μA	3μA	32K	24K	8M	7.37M
TM52-F5278C									
TM52-F5273B	1.8~5.5V	2.5mA	12μA	6μA	3μA	32K	24K	10M	9.83M
TM52-F5276B									
TM52-F5288C	1.9~5.5V	2.3mA	22μA	4.5μA	<0.1μA	32K	80K	8M	7.37M
TM52-F5284C									

## GENERAL DESCRIPTION

**TM52** Series **F5264B/64C/68B/68C** are versions of a new, fast 8051 architecture for an 8-bit microcontroller single chip with an instruction set fully compatible with industry standard 8051, and retains most 8051 peripheral's function block. Typically, the **TM52** executes instructions six times faster than the standard 8051 architecture.

The **TM52-F5264B/64C/68B/68C** provides improved performance, lower cost and fast time-to-market by integrating features on the chip, including 8K Bytes Flash program memory, 256 Bytes SRAM, Low Voltage Reset (LVR), Low Voltage Detector (LVD), dual clock power saving operation mode, SPI Interface, 8051 standard UART and Timer0/1/2, real time clock Timer3, 2 set (8+2)-bit PWMs, 12 channels 12-bit A/D Converter, 14 channels Touch Key (F5268) and Watchdog Timer. Its high reliability and low power consumption feature can be widely applied in consumer and home appliance products.

## BLOCK DIAGRAM

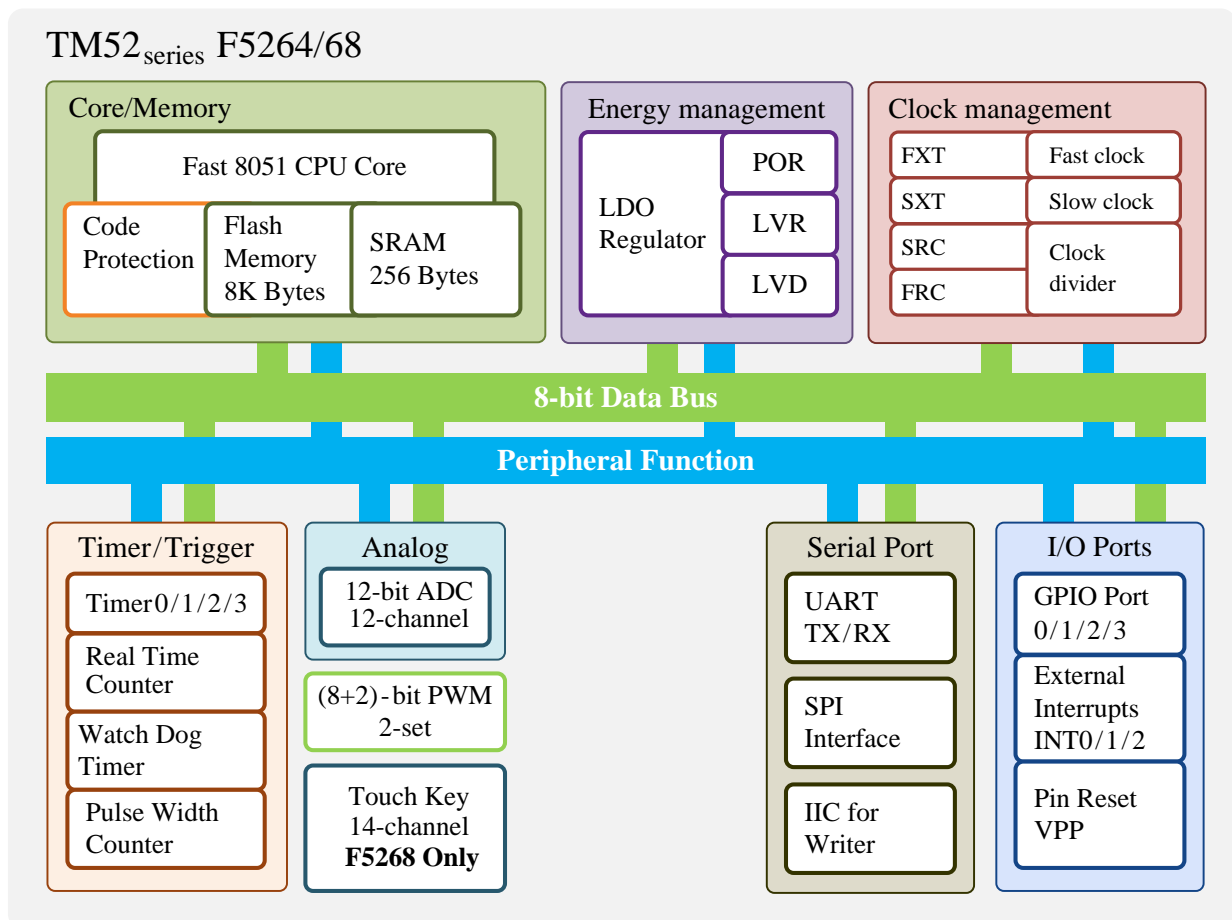

## FEATURES

- 1. Standard 8051 Instruction set, fast machine cycle**
  - Executes instructions six times faster than the standard 8051
- 2. 8K Bytes Flash Program Memory**
  - Support “In Circuit Programming” (ICP) or “In System Programming” (ISP) for the Flash code
  - Byte Write “In Application Programming” (IAP) mode is convenient as Data EEPROM access
  - Code Protection Capability
- 3. 256 Bytes SRAM in the 8051 internal data memory area (IRAM)**
- 4. Four System Clock type Selections**
  - Fast clock from 1~8 MHz Crystal (FXT)
  - Fast clock from Internal RC (FRC, 7.3728 MHz)
  - Slow clock from 32768 Hz Crystal (SXT)
  - Slow clock from Internal RC (SRC, 24 KHz)
  - System clock can be divided by 1/2/4/16 option
- 5. 8051 Standard Timer – Timer0/1/2**
  - 16-bit Timer0, also supports T0O clock output for Buzzer application
  - 16-bit Timer1
  - 16-bit Timer2, also supports T2O clock output for Buzzer application
- 6. 15-bit Time3**
  - Clock source is Slow clock
  - Interrupt period can be clock divided by 32768/16384/8192/128 option
- 7. 8051 Standard UART**
  - One Wire UART option can be used for ISP or other application
- 8. Two independent "8+2" bits PWMs with prescaler/period-adjustment**
- 9. SPI Interface**
  - Master or Slave mode selectable
  - Programmable transmit bit rate
  - Serial clock phase and polarity options
  - MSB-first or LSB-first selectable
- 10. 14-Channel Touch Key (F5268 only)**
- 11. 12-bit ADC with 10 Channels External Pin Input and 2 Channels Internal Reference Voltage**

**12. 11 Sources, 4-level Priority Interrupt**

- Timer0/Timer1/Timer2/Timer3 Interrupt
- INT0/INT1 Falling-Edge/Low-Level Interrupt
- Port1 Pin Change Interrupt
- UART TX/RX Interrupt
- P3.7 (INT2) Interrupt
- ADC/Touch Key Interrupt
- SPI Interrupt

**13. Pin Interrupt can Wake up CPU from Power-Down (Stop) mode**

- P3.2/P3.3 (INT0/INT1) Interrupt & Wake-up
- P3.7 (INT2) Interrupt & Wake-up
- Each Port1 pin can be defined as Interrupt & Wake-up pin (by pin change)

**14. Max. 22 Programmable I/O pins**

- CMOS Output
- Pseudo-Open-Drain, or Open-Drain Output
- Schmitt Trigger Input
- Pin Pull-up can be Enable or Disable

**15. Independent RC Oscillating Watchdog Timer**

- 360ms/180ms/90ms/45ms Selectable WDT Timeout options

**16. Five types Reset**

- Power on Reset
- Selectable External Pin Reset
- Software Command Reset
- Selectable Watchdog Timer Reset
- Selectable Low Voltage Reset

**17. 3-level Low Voltage Reset**

- F5264B/68B: 1.8V/2.3V/2.9V (can be disabled)
- F5264C/68C: 2.0V/2.3V/2.9V

**18. 1-level Low Voltage Detect**

- 2.3V (can be disabled)

**19. Four Power Saving Operation Modes**

- Fast/Slow/Idle/Stop Mode



**20. On-chip Debug/ICE interface**

- Use P3.0/P3.1 pin
- Share with ICP programming pin

**21. Operating Voltage and Current**

- VCC=2.9V ~ 5.5V @FSYSCLK=7.3728 MHz
- VCC=2.3V ~ 5.5V @FSYSCLK=3.6864 MHz
- ICC=3μA @Stop mode, MODE3V=0, PWRSV=1, VCC=3V
- ICC=3μA @Stop mode, MODE3V=1, PWRSV=1, VCC=3V

**22. Operating Temperature Range**

- F5264B/68B: -20°C ~ +70°C
- F5264C/68C: -40°C ~ +85°C

**23. Package Types**

- DIP 20-pin (300 mil)
- SOP 20-pin (300 mil)
- SSOP 20-pin (209 mil)
- SOP 24-pin (300 mil)
- SSOP 24-pin (209 mil)

**F5264B/F5264C/F5268B/F5268C Features comparison table**

Features	F5264B	F5268B	F5264C	F5268C
Touch Key	n.a.	Yes	n.a.	Yes
LVR	1.8V/2.3V/2.9V (can be disabled)		2.0V/2.3V/2.9V	
Stop Mode Current	0.6uA		3uA	

## PIN ASSIGNMENT

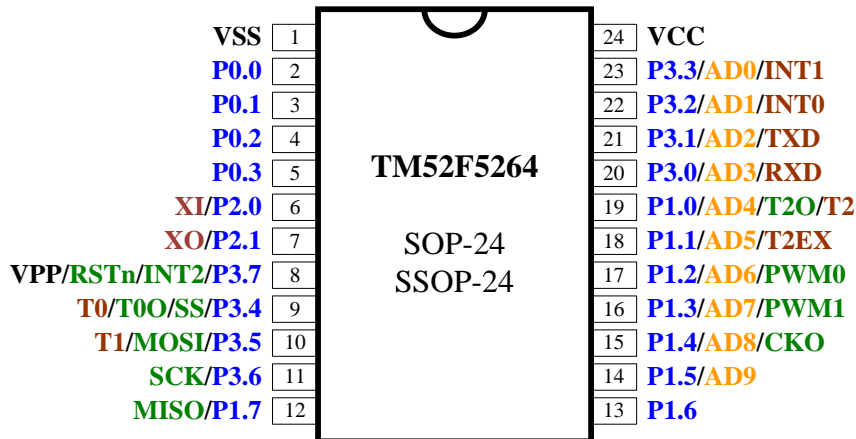
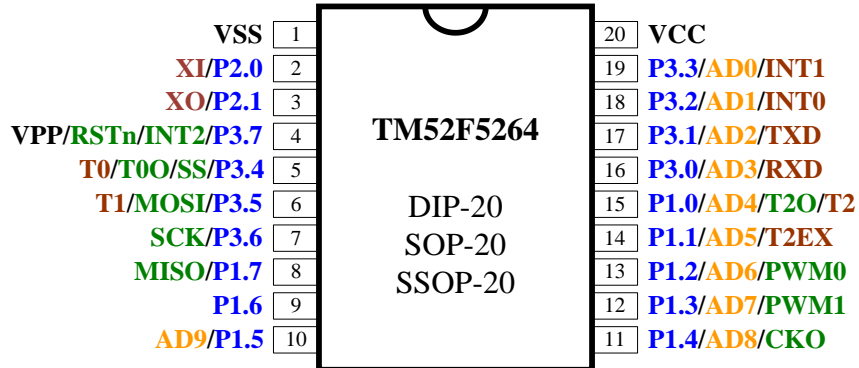

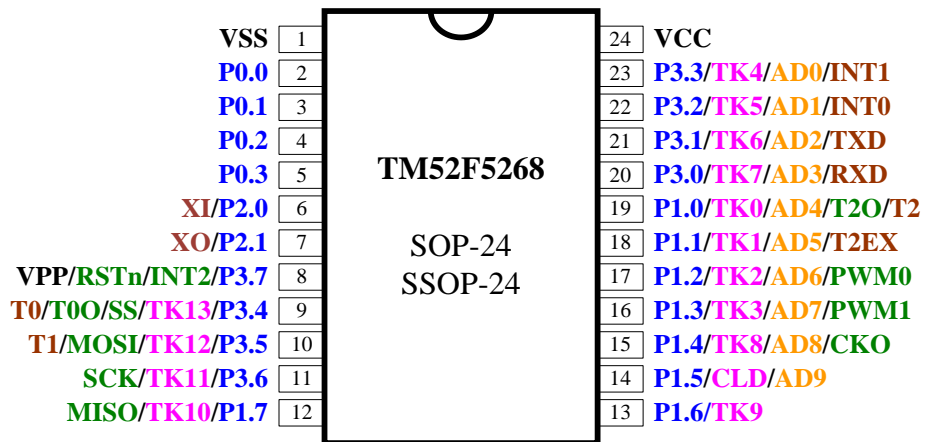
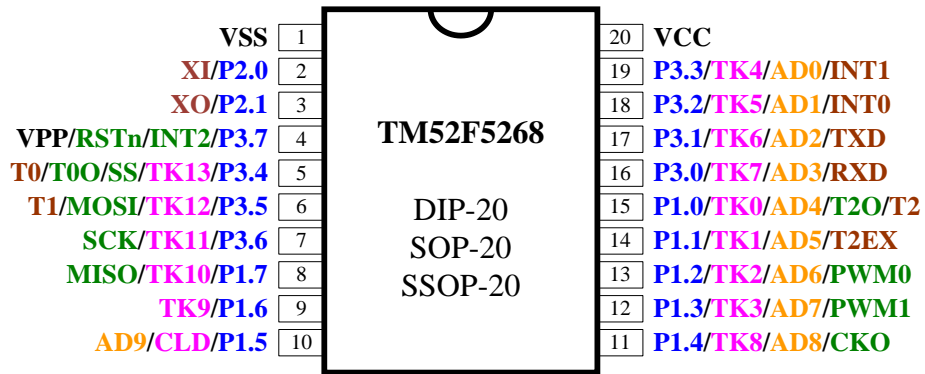

**PIN DESCRIPTION**

Name	In/Out	Pin Description
P0.0~P0.3	I/O	Bit-programmable I/O port for Schmitt-trigger input or CMOS push-pull output. Pull-up resistors are assignable by software.
P1.0~P1.7	I/O	Bit-programmable I/O port for Schmitt-trigger input, CMOS push-pull output or “open-drain” output. Pull-up resistors are assignable by software. These pin’s level change can wake up CPU from Idle/Stop mode.
P2.0~P2.1	I/O	Bit-programmable I/O port for Schmitt-trigger input, CMOS push-pull output or “open-drain” output. Pull-up resistors are assignable by software.
P3.0~P3.2	I/O	Bit-programmable I/O port for Schmitt-trigger input, CMOS push-pull output or “pseudo open drain” output. Pull-up resistors are assignable by software.
P3.3~P3.6	I/O	Bit-programmable I/O port for Schmitt-trigger input, CMOS push-pull output or “open-drain” output. Pull-up resistors are assignable by software.
P3.7	I/O	Bit-programmable I/O port for Schmitt-trigger input or “open-drain” output. Pull-up resistor is fix enable.
INT0, INT1	I	External low level or falling edge Interrupt input, Idle/Stop mode wake up input.
INT2	I	External falling edge Interrupt input, Idle/Stop mode wake up input.
RXD	I/O	UART Mode0 transmit & receive data, Mode1/2/3 receive data
TXD	I/O	UART Mode0 transmit clock, Mode1/2/3 transmit data. In One Wire UART mode, this pin transmits and receives serial data.
T0, T1, T2	I	Timer0, Timer1, Timer2 event count pin input
T0O	O	Timer0 overflow divided by 64 output
T2O	O	Timer2 overflow divided by 2 output
CKO	O	System Clock divided by 2 output
T2EX	I	Timer2 external trigger input
PWM0 PWM1	O	8+2 bit PWM output
AD0~AD9	I	ADC input
TK0~TK13	I	Touch Key input
CLD	I/O	Touch Key charge collection capacitor connection pin
MISO	I/O	SPI data input for master mode, data output for slave mode
MOSI	I/O	SPI data output for master mode, data input for slave mode
SS	I	SPI active low slave select input for slave mode
SCK	I/O	SPI clock output for master or clock input for slave mode
RSTn	I	External active low reset input, Pull-up resistor is fixed enable
XI, XO	–	Crystal/Resonator oscillator connection for system clock
VPP	I	Flash programming high voltage input
VCC, VSS	P	Power input pin and ground

## PIN SUMMARY

### TM52F5264

Pin Number		Pin Name	Type	Input			Output			Alternate Function					Misc
SSOP/SOP-24	DIP/SOP-20			Pull-up Control	Wake up	Ext. Interrupt	P.P.	P.O.D.	O.D.	ADC	SPI	UART	PWM	Timer	
1	1	VSS	P												
2		P0.0	I/O	⊙			●								
3		P0.1	I/O	⊙			●								
4		P0.2	I/O	⊙			●								
5		P0.3	I/O	⊙			●								
6	2	XI/P2.0	I/O	⊙			●	●							Crystal
7	3	XO/P2.1	I/O	⊙			●	●							Crystal
8	4	VPP/RSTn/INT2/P3.7	I/O	⊙	●	●		●							Reset
9	5	T0/T0O/SS/P3.4	I/O	⊙			●	●		●			●		
10	6	T1/MOSI/P3.5	I/O	⊙			●	●		●			●		
11	7	SCK/P3.6	I/O	⊙			●	●		●					
12	8	MISO/P1.7	I/O	⊙	●		●	●		●					
13	9	P1.6	I/O	⊙	●		●	●							
14	10	AD9/P1.5	I/O	⊙	●		●	●	●						
15	11	CKO/AD8/P1.4	I/O	⊙	●		●	●	●						
16	12	PWM1/AD7/P1.3	I/O	⊙	●		●	●	●			●			
17	13	PWM0/AD6/P1.2	I/O	⊙	●		●	●	●			●			
18	14	T2EX/AD5/P1.1	I/O	⊙	●		●	●	●				●		
19	15	T2/T2O/AD4/P1.0	I/O	⊙	●		●	●	●				●		
20	16	RXD/AD3/P3.0	I/O	⊙			●	●	●		●				
21	17	TXD/AD2/P3.1	I/O	⊙			●	●	●		●				
22	18	INT0/AD1/P3.2	I/O	⊙	●	●	●	●	●						
23	19	INT1/AD0/P3.3	I/O	⊙	●	●	●	●	●						
24	20	VCC	P												

Symbol:

- P.P. = Push-Pull Output
- O.D. = Open Drain
- P.O.D. = Pseudo Open Drain

PS:

1. ⊙ 3.7 Pull up resistor is fix enable
2. ● Port1, P2.0, P2.1, Port3 these pins control Pull up resistor by operation modes
3. ⊙ P0.3~P0.0 control Pull up resistor while PxOE.n=0 and Px.n=1

**TM52F5268**

Pin Number		Pin Name	Type	Input			Output			Alternate Function					Misc	
SSOP/SOP-24	DIP/SOP-20			Pull-up Control	Wake up	Ext. Interrupt	P.P.	P.O.D.	O.D.	ADC	Touch-Key	SPI	UART	PWM		Timer
1	1	VSS	P													
2		P0.0	I/O	⊙			●									
3		P0.1	I/O	⊙			●									
4		P0.2	I/O	⊙			●									
5		P0.3	I/O	⊙			●									
6	2	XI/P2.0	I/O	●			●	●								Crystal
7	3	XO/P2.1	I/O	●			●	●								Crystal
8	4	VPP/RSTn/INT2/P3.7	I/O	⊙	●	●		●								Reset
9	5	T0/T0O/SS/TK13/P3.4	I/O	●			●	●		●	●				●	
10	6	T1/MOSI/TK12/P3.5	I/O	●			●	●		●	●				●	
11	7	SCK/TK11/P3.6	I/O	●			●	●		●	●					
12	8	MISO/TK10/P1.7	I/O	●	●		●	●		●	●					
13	9	TK9/P1.6	I/O	●	●		●	●		●						
14	10	AD9/CLD/P1.5	I/O	●	●		●	●	●	●						
15	11	CKO/AD8/TK8/P1.4	I/O	●	●		●	●	●	●						
16	12	PWM1/AD7/TK3/P1.3	I/O	●	●		●	●	●	●			●			
17	13	PWM0/AD6/TK2/P1.2	I/O	●	●		●	●	●	●			●			
18	14	T2EX/AD5/TK1/P1.1	I/O	●	●		●	●	●	●					●	
19	15	T2/T2O/AD4/TK0/P1.0	I/O	●	●		●	●	●	●					●	
20	16	RXD/AD3/TK7/P3.0	I/O	●			●	●		●	●		●			
21	17	TXD/AD2/TK6/P3.1	I/O	●			●	●		●	●		●			
22	18	INT0/AD1/TK5/P3.2	I/O	●	●	●	●	●		●	●					
23	19	INT1/AD0/TK4/P3.3	I/O	●	●	●	●	●		●	●					
24	20	VCC	P													

Symbol:

- P.P. = Push-Pull Output
- O.D. = Open Drain
- P.O.D. = Pseudo Open Drain

PS:

1. ⊙ P3.7 Pull up resistor is fix enable
2. ● Port1, P2.0, P2.1, Port3 these pins control Pull up resistor by operation modes
3. ⊙ P0.3~P0.0 control Pull up resistor while PxOE.n=0 and Px.n=1

## FUNCTIONAL DESCRIPTION

### 1. CPU Core

In the 8051 architecture, the C programming language is used as a development platform. The TM52 device features a fast 8051 core in a highly integrated microcontroller, allowing designers to be able to achieve improved performance compared to a classic 8051 device. TM52 series microcontrollers provide a complete binary code with standard 8051 instruction set compatibility, ensuring an easy migration path to accelerate the development speed of system products. The CPU core includes an ALU, a program status word (PSW), an accumulator (ACC), a B register, a stack point (SP), DPTRs, a program counter, an instruction decoder, and core special function registers (SFRs).

#### 1.1 Accumulator (ACC)

This register provides one of the operands for most ALU operations. Accumulators are generally referred to as A or Acc and sometimes referred to as Register A. In this document, the accumulator is represented as “A” or “ACC” including the instruction table. The accumulator, as its name suggests, is used as a general register to accumulate the intermediate results of a large number of instructions. The accumulator is the most important and frequently used register to complete arithmetic and logical operations. It holds the intermediate results of most arithmetic and logic operations and assists in data transportation.

SFR E0h	Bit 7	Bit 6	Bit 5	Bit 4	Bit 3	Bit 2	Bit 1	Bit 0
<b>ACC</b>	ACC.7	ACC.6	ACC.5	ACC.4	ACC.3	ACC.2	ACC.1	ACC.0
R/W	R/W	R/W	R/W	R/W	R/W	R/W	R/W	R/W
Reset	0	0	0	0	0	0	0	0

E0h.7~0 **ACC**: Accumulator

#### 1.2 B Register (B)

The “B” register is very similar to the ACC and may hold a 1 Byte value. This register provides the second operand for multiply or divide instructions. Otherwise, it may be used as a scratch pad register. The B register is only used by two 8051 instructions, MUL and DIV. When A is to be multiplied or divided by another number, the other number is stored in B. For MUL and DIV instructions, it is necessary that the two operands are in A and B.

ex: DIV AB

When this instruction is executed, data inside A and B are divided, and the answer is stored in A.

SFR F0h	Bit 7	Bit 6	Bit 5	Bit 4	Bit 3	Bit 2	Bit 1	Bit 0
<b>B</b>	B.7	B.6	B.5	B.4	B.3	B.2	B.1	B.0
R/W	R/W	R/W	R/W	R/W	R/W	R/W	R/W	R/W
Reset	0	0	0	0	0	0	0	0

F0h.7~0 **B**: B register

### 1.3 Stack Pointer (SP)

The SP register contains the Stack Pointer. The Stack Pointer is used to load the program counter into memory during LCALL and ACALL instructions and is used to retrieve the program counter from memory in RET and RETI instructions. The stack may also be saved or loaded using PUSH and POP instructions, which also increment and decrement the Stack Pointer. The Stack Pointer points to the top location of the stack.

SFR 81h	Bit 7	Bit 6	Bit 5	Bit 4	Bit 3	Bit 2	Bit 1	Bit 0
<b>SP</b>	SP							
R/W	R/W							
Reset	0	0	0	0	0	1	1	1

81h.7~0 **SP:** Stack Point

### 1.4 Dual Data Pointer (DPTRs)

TM52 device has two DPTRs, which share the same SFR address. Each DPTR is 16 bits in size and consists of two registers: the DPTR high byte (DPH) and the DPTR low byte (DPL). The DPTR is used for 16-bit-address external memory accesses, for offset code byte fetches, and for offset program jumps. Setting the DPSEL control bit allows the program code to switch between the two physical DPTRs.

SFR 82h	Bit 7	Bit 6	Bit 5	Bit 4	Bit 3	Bit 2	Bit 1	Bit 0
<b>DPL</b>	DPL							
R/W	R/W							
Reset	0	0	0	0	0	0	0	0

82h.7~0 **DPL:** Data Point low byte

SFR 83h	Bit 7	Bit 6	Bit 5	Bit 4	Bit 3	Bit 2	Bit 1	Bit 0
<b>DPH</b>	DPH							
R/W	R/W							
Reset	0	0	0	0	0	0	0	0

83h.7~0 **DPH:** Data Point high byte

SFR F8h	Bit 7	Bit 6	Bit 5	Bit 4	Bit 3	Bit 2	Bit 1	Bit 0
<b>AUX1</b>	CLRWDT	CLRTM3	TKSOC	ADSOC	CLRPWM0	–	–	DPSEL
R/W	R/W	R/W	R/W	R/W	R/W	–	–	R/W
Reset	0	0	0	0	0	–	–	0

F8h.0 **DPSEL:** Active DPTR Select



### 1.5 Program Status Word (PSW)

This register contains status information resulting from CPU and ALU operations. The instructions that affect the PSW are listed below.

Instruction	Flag			Instruction	Flag		
	C	OV	AC		C	OV	AC
ADD	X	X	X	CLR C	0		
ADDC	X	X	X	CPL C	X		
SUBB	X	X	X	ANL C, bit	X		
MUL	0	X		ANL C, /bit	X		
DIV	0	X		ORL C, bit	X		
DA	X			ORL C, /bit	X		
RRC	X			MOV C, bit	X		
RLC	X			CJNE	X		
SETB C	1						

A “0” means the flag is always cleared, a “1” means the flag is always set and an “X” means that the state of the flag depends on the result of the operation.

SFR D0h	Bit 7	Bit 6	Bit 5	Bit 4	Bit 3	Bit 2	Bit 1	Bit 0
PSW	CY	AC	F0	RS1	RS0	OV	F1	P
R/W	R/W	R/W	R/W	R/W	R/W	R/W	R/W	R/W
Reset	0	0	0	0	0	0	0	0

- D0h.7 **CY**: ALU carry flag
- D0h.6 **AC**: ALU auxiliary carry flag
- D0h.5 **F0**: General purpose user-definable flag
- D0h.4~3 **RS1, RS0**: The contents of (RS1, RS0) enable the working register banks as:
  - 00: Bank 0 (00h~07h)
  - 01: Bank 1 (08h~0Fh)
  - 10: Bank 2 (10h~17h)
  - 11: Bank 3 (18h~1Fh)
- D0h.2 **OV**: ALU overflow flag
- D0h.1 **F1**: General purpose user-definable flag
- D0h.0 **P**: Parity flag. Set/cleared by hardware each instruction cycle to indicate odd/even number of “one” bits in the accumulator.

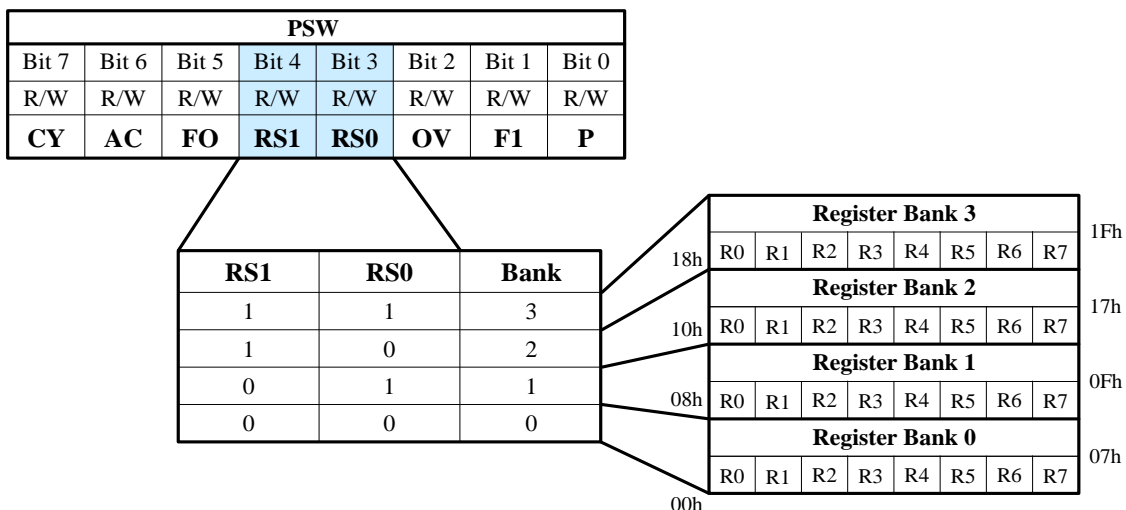

## 2. Memory

### 2.1 Program Memory

The Chip has an 8K Bytes Flash program memory, which can support In Circuit Programming (ICP), In Application Programming (IAP) and In System Programming (ISP) function modes. The Flash write endurance is at least 50K cycles. The Flash program memory address continuous space (0000h~1FFFh) is partitioned to several sectors for device operation.

#### 2.1.1 Program Memory Functional Partition

The last 2 bytes (1FFEh~1FFFh) of program memory is defined as chip Configuration Word (CFGW), which is loaded into the device control registers upon power on reset (POR). The address space 1F00h~1FFDh is the IAP free area, while the 0000h~005Fh is occupied by Reset/Interrupt vectors as standard 8051 definition. In the in-circuit emulation (ICE) mode, user also needs to reserve the address space 0D00h~0FFFh for ICE System communication.

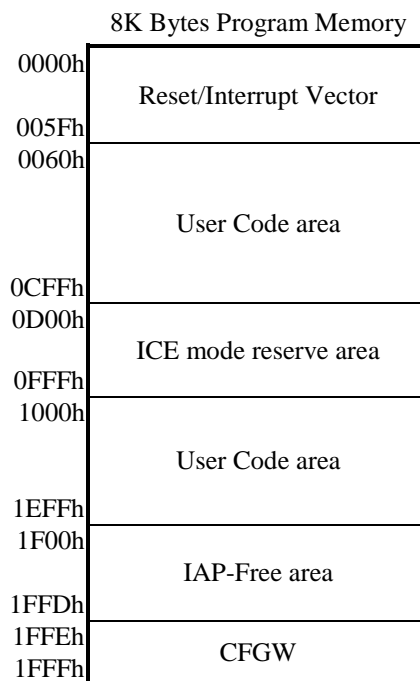

#### 2.1.2 Flash ICP Mode

The Flash memory can be programmed by the tenx proprietary writer (**TWR98/TWR99**), which needs at least four wires (VCC, VSS, P3.0 and P3.1 pins) to connect to this chip. To shorten the programming time, it is recommended to connect Writer with an additional fifth wire, which is the VPP (P3.7) pin. If the user wants to program the Flash memory on the target circuit board (In Circuit Programming, ICP), these pins must be reserved sufficient freedom to be connected to the Writer. More pins connected to Writer ensure more writing efficiency and speed.

Writer wire number	Pin connection
4-Wire	VCC, VSS, P3.0, P3.1
5-Wire	VCC, VSS, P3.0, P3.1, VPP
7-Wire	VCC, VSS, P3.0, P3.1, VPP, P3.3, P1.2 <i>Note:</i> P3.2 output FRC/2 and P3.5 always output Low in this mode

### 2.1.3 Flash IAP Mode

The Chip has “In Application Programming” (IAP) capability, which allows software to read/write data from/to the Flash memory during CPU run time as conveniently as data EEPROM access. The IAP function is byte writable, meaning that the Chip does not need to erase one Flash page before write. The available IAP data space is 254 Bytes after chip reset, and can be re-defined by the “MVCLOCK” and “IAPALL” control register as shown below.

8K Bytes Flash Program Memory		Flash Memory	MVCLOCK	IAPALL	MOVC Accessible	MOVX (IAP) Accessible
0000h	MOVC-Lock area	0000h~01FFh	1	X	No	No
01FFh			0	0	Yes	No
0200h			0	1	Yes	Yes
0200h	IAP-All area	0200h~1EFFh	X	0	Yes	No
1EFFh			X	1	Yes	Yes
1F00h	IAP-Free area	1F00h~1FFDh	X	X	Yes	Yes
1FFEh	CFGW area	1FFEh	X	0	Yes	No
1FFFh			X	1	Yes	Yes
1FFFh			X	X	Yes	No

In IAP mode, the program Flash memory is separated into four sectors: MOVC-Lock area, IAP-All area, IAP-Free area, and CFGW area. These four sectors are regulated differently.

In the **MOVC-Lock area**, IAP read/write is limited by MVCLOCK bit, which can be set to control the accessibility of the MOVC and MOVX instructions to this area. The size of this area is 512 Bytes. The lock function is made to protect the main program code against unconsciously writing Flash memory in IAP mode. Locking or unlocking the function should be performed by the tenx TWR98/99 writing to the CFGW in Flash memory.

The **IAP-All area** is protected by the IAPALL register to prevent IAP mode from writing application data to the program area, resulting in a program code error that cannot be repaired. The size of this area is 7424 Bytes. Enabling IAPALL requires writing 65h to SFR SWCMD 97h to set the IAPALL control flag. Then, software can use MOVX instructions to write application data to flash memory from 0200h to 1EFFh. If user wants to disable IAPALL function, user can write other values to SFR SWCMD 97h to clear the IAPALL control flag. User must be careful not to overwrite program code which is already resided on the same Flash memory area.

The **IAP-Free area** has no control bit to protect. It can be used to reliably store system application data that needs to be programmed once or periodically during system operation. Other areas of Flash memory can be used to store data, but this area is usually the best. The size of this area is 254 Bytes, equivalent to an EEPROM, and Flash memory can provide byte access to read and write commands. In the past, storage of configuration data required an additional EEPROM or the other storage device. However, this functionality can now be provided by on-chip Flash, reducing the chip count of embedded applications. An external EEPROM or SRAM may not be needed.

The **CFGW area** has 2 data bytes (CFGWH and CFGWL), which is located at the last 2 addresses of Flash memory. The CFGWH is not accessible to IAP, while the CFGWL can be read or written by IAP in case the IAPALL flag is set. CFGWL is copied to the SFR F7h after power on reset, software then take over CFGWL’s control capability by modifying the SFR F7h.

### 2.1.4 IAP Mode Access Routines

Flash IAP write is simply achieved by a “MOVX @DPTR, A” instruction while the DPTR contains the target Flash address (0000h~1FFEh), and the ACC contains the data being written. The Chip accepts IAP Write command only when the IAPWE SFR is enabled. Flash IAP writing requires approximately 500μs. Meanwhile, the CPU stays in a waiting state, but all peripheral modules (Timers and others) continue running during the writing time. The software must handle the pending interrupts after an IAP write. Flash IAP writing needs higher V<sub>CC</sub> voltage, V<sub>CC</sub>>2.8V.

Because the Program memory and the IAP data space share the same entity, a Flash IAP read can be performed by the “MOVX A, @DPTR” or “MOVC” instruction as long as the target address points to the 0000h~1FFFh area. A Flash IAP read does not require extra CPU wait time.

; IAP example code

; need V<sub>CC</sub>>2.8V

```

MOV     DPTR, #1F00h      ; DPTR=1F00h=target IAP address
MOV     A, #5Ah          ; A=5Ah=target IAP write data
MOV     INTE1, #A0h      ; IAPWE=1
MOVX    @DPTR, A         ; Flash[1F00h] =5Ah, after IAP write
                          ; 200μs~500μs H/W writing time, CPU wait

MOV     INTE1, #00h      ; IAPWE=0 immediately after IAP write
CLR     A                ; A=0
MOVX    A, @DPTR         ; A=5Ah
CLR     A                ; A=0
MOVC   A, @A+DPTR       ; A=5Ah
    
```

Flash 1FFFh	Bit 7	Bit 6	Bit 5	Bit 4	Bit 3	Bit 2	Bit 1	Bit 0
<b>CFGWH</b>	PROT	XRSTE	LVRE		VCCFLT	PWRSV	MVCLOCK	–

1FFFh.1 **MVCLOCK:** If 1, the MOVC & MOVX instruction’s accessibility to MOVC-Lock area is limited.

SFR 97h	Bit 7	Bit 6	Bit 5	Bit 4	Bit 3	Bit 2	Bit 1	Bit 0
<b>SWCMD</b>	IAPALL/SWRST							
R/W	W							R/W
Reset	–							0

97h.7~0 **IAPALL (W):** Write 65h to set IAPALL control flag; Write other value to clear IAPALL flag. It is recommended to clear it immediately after IAP access.

97h.0 **IAPALL (R):** Flag indicates Flash memory sectors can be accessed by IAP or not. This bit combines with MVCLOCK to define the accessible IAP area.

SFR A9h	Bit 7	Bit 6	Bit 5	Bit 4	Bit 3	Bit 2	Bit 1	Bit 0
<b>INTE1</b>	IAPWE			SPIE	TKIE	EX2	PIIE	TM3IE
R/W	R/W			R/W	R/W	R/W	R/W	R/W
Reset	0	0	0	0	0	0	0	0

A9h.7~5 **IAPWE:** IAP write enable control

101: Enable IAP write. It is recommended to clear it immediately after IAP write.

Others value: Disable IAP write.

### 2.1.5 Flash ISP Mode

The “In System Programming” (ISP) usage is similar to IAP, except the purpose is to refresh the Program code. User can use UART/SPI or other method to get new Program code from external host, then writes code as the same way as IAP. ISP operation is complicated; basically it needs to assign a Boot code area to the Flash which does not change during the ISP process.

## 2.2 Data Memory

As the standard 8051, the Chip has both Internal and External Data Memory space. The Internal Data Memory space consists of 256 Bytes IRAM and 64 SFRs, which are accessible through a rich instruction set. IAP Flash can be only accessed by MOVX instruction.

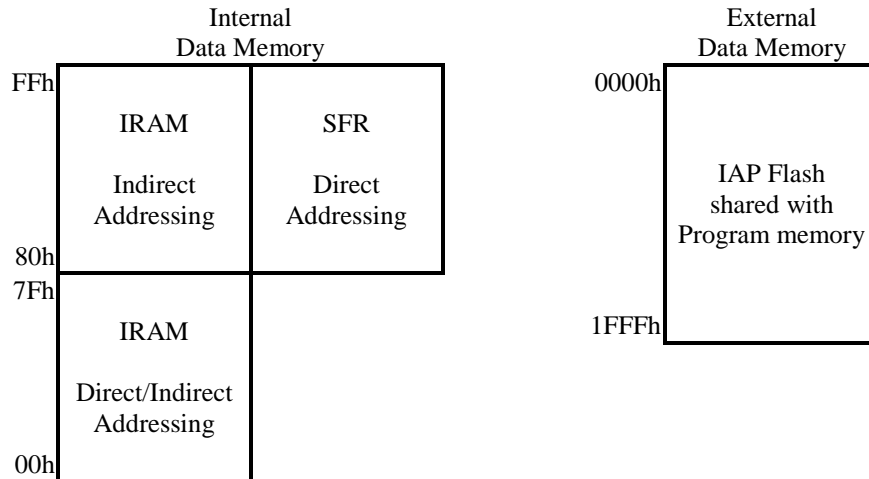

### 2.2.1 IRAM

IRAM is located in the 8051 internal data memory space. The whole 256 Bytes IRAM are accessible using indirect addressing but only the lower 128 Bytes are accessible using direct addressing. There are four directly addressable register banks (switching by PSW), which occupy IRAM space from 00h to 1Fh. The address 20h to 2Fh 16 Bytes IRAM space is bit-addressable. IRAM can be used as scratch pad registers or program stack.

### 2.2.2 SFRs

All peripheral functional modules such as I/O ports, Timers and UART operations for the chip are accessed via Special Function Registers (SFRs). These registers occupy upper 128 Bytes of direct Data Memory space locations in the range 80h to FFh. There are 14 bit-addressable SFRs (which means that eight individual bits inside a single byte are addressable), such as ACC, B register, PSW, TCON, SCON, and others. The remaining SFRs are only byte addressable. SFRs provide control and data exchange with the resources and peripherals of the Chip. The TM52 series of microcontrollers provides complete binary code with standard 8051 instruction set compatibility. Beside the standard 8051 SFRs, the Chip implements additional SFRs used to configure and access subsystems such as the SPI, which are unique to the Chip.

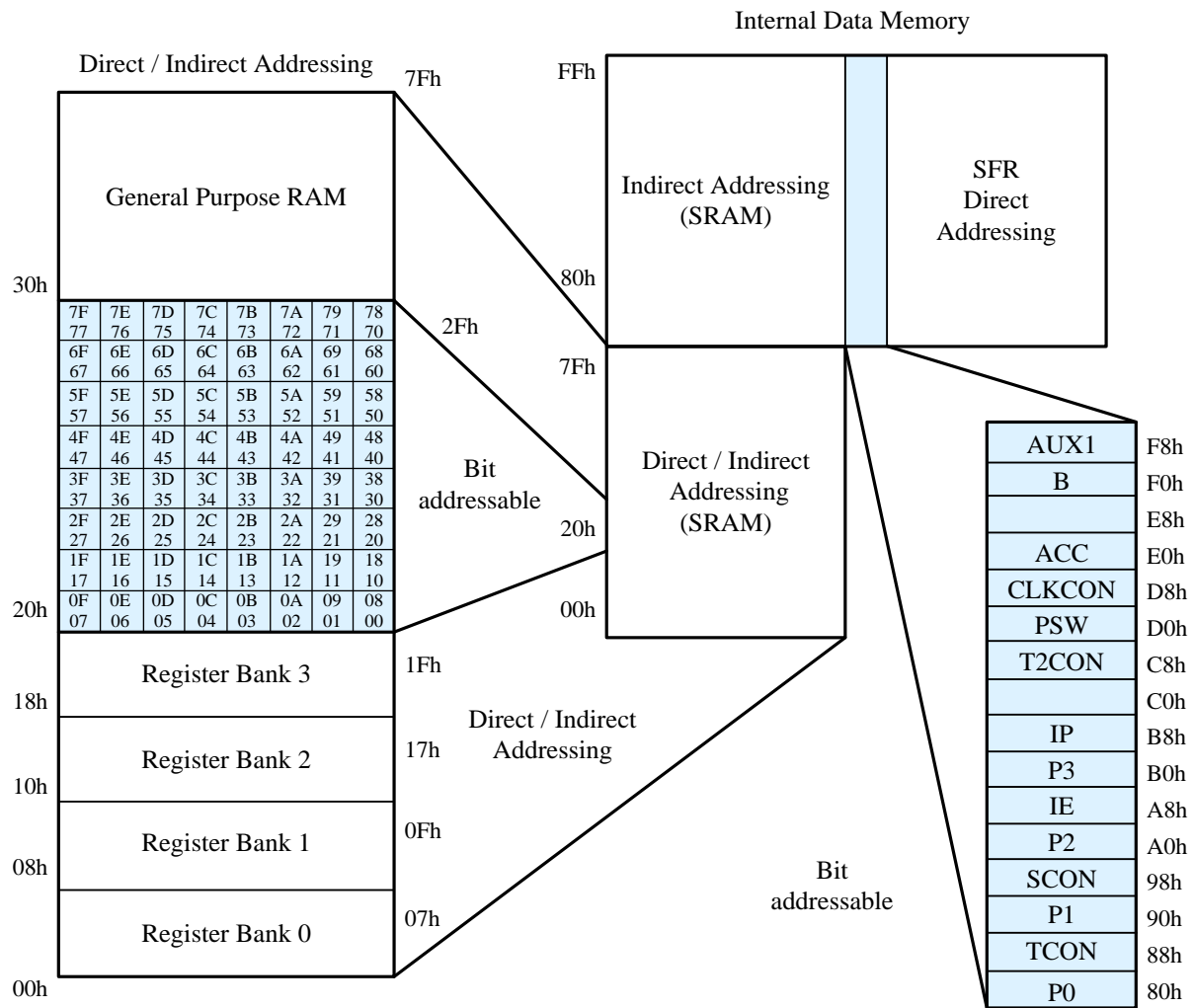

	8/0	9/1	A/2	B/3	C/4	D/5	E/6	F/7
F8h	AUX1							
F0h	B							CFGWL
E8h								
E0h	ACC							
D8h	CLKCON							
D0h	PSW							
C8h	T2CON		RCP2L	RCP2H	TL2	TH2		
C0h			ATKC10H	ATKC32H	ATKC0L	ATKC1L	ATKC2L	ATKC3L
B8h	IP	IPH	IP1	IP1H	SPCON	SPSTA	SPDAT	
B0h	P3							
A8h	IE	INTE1	ADTKDT	ADCDH	TKDL	TKCON	CHSEL	TKCON2
A0h	P2	PWMCON	P1MODL	P1MODH	P3MODL	P3MODH	PINMOD	
98h	SCON	SBUF	PWM0PRD	PWM0DH	PWM1PRD	PWM1DH		
90h	P1	POOE		P2MOD	OPTION	INTFLG	P1WKUP	SWCMD
88h	TCON	TMOD	TL0	TL1	TH0	TH1		
80h	P0	SP	DPL	DPH				PCON

### 3. Power

The Chip has a built-in internal low dropout regulator. When MODE3V=0, the voltage regulator outputs 3.3V power to the internal chip circuit. When MODE3V=1, the LDO is turned off, and the internal circuit receives a power supply directly from the VCC pin. Because the LDO consumes 150µA for operation, turning off LDO by setting MODE3V=1 can reduce the chip current consumption. However, setting MODE3V=1 is only valid for an operating condition of  $V_{CC} < 3.6V$ . The PWRSV also control the LDO. When MODE3V=0 and PWRSV=1, the LDO is turned off in Stop mode for saving power consumption. In addition, set PWRSV will affect the LVR/LVD setting.

#### MODE3V=0

Operation Mode	CFGW		Tiny Current	LDO	LVR	LVD	Function
	PWRSV	LVRE					
Fast Slow Idle	X	00	–	ON	ON	–	LV Reset 2.9V
	X	01	–	ON	ON	–	LV Reset 2.3V
	X	10	–	ON	ON	ON	LV Reset Disable/2.0V
	X	11	–	ON	ON	ON	LV Reset 1.8V/2.0V
Stop	0	00	–	ON	ON	–	LV Reset 2.9V
	0	01	–	ON	ON	–	LV Reset 2.3V
	0	10	–	ON	ON	–	LV Reset Disable/2.0V
	0	11	–	ON	ON	–	LV Reset 1.8V/2.0V
	1	00	Y	OFF	ON	–	LV Reset 1.8V/2.0V
	1	01	Y	OFF	ON	–	LV Reset 1.8V/2.0V
	1	10	Y	OFF	ON	–	LV Reset Disable/2.0V
	1	11	Y	OFF	ON	–	LV Reset 1.8V/2.0V

#### MODE3V=1

Operation Mode	CFGW		Tiny Current	LDO	LVR	LVD	Function
	PWRSV	LVRE					
Fast Slow Idle	0	00	–	OFF	ON	–	LV Reset 2.9V
	0	01	–	OFF	ON	–	LV Reset 2.3V
	0	10	–	OFF	ON	ON	LV Reset Disable/2.0V
	0	11	–	OFF	ON	ON	LV Reset 1.8V/2.0V
	1	00	Slow, Idle	OFF	ON	–	LV Reset 1.8V/2.0V
	1	01	Slow, Idle	OFF	ON	–	LV Reset 1.8V/2.0V
	1	10	Slow, Idle	OFF	ON	–	LV Reset Disable/2.0V
	1	11	Slow, Idle	OFF	ON	–	LV Reset 1.8V/2.0V
Stop	0	00	–	OFF	ON	–	LV Reset 2.9V
	0	01	–	OFF	ON	–	LV Reset 2.3V
	0	10	–	OFF	ON	–	LV Reset Disable/2.0V
	0	11	Y	OFF	ON	–	LV Reset 1.8V/2.0V
	1	00	Y	OFF	ON	–	LV Reset 1.8V/2.0V
	1	01	Y	OFF	ON	–	LV Reset 1.8V/2.0V
	1	10	Y	OFF	ON	–	LV Reset Disable/2.0V
	1	11	Y	OFF	ON	–	LV Reset 1.8V/2.0V

**Note:** Typical Tiny current of F5264B/68B are Slow=13uA, Idle=5uA and Stop=1uA @VCC=3V, 32KHz

Typical Tiny current of F5264C/68C are Slow=16uA, Idle=8uA and Stop=3uA @VCC=3V, 32KHz

**Note:** FW must turn off Bandgap to obtain Tiny Current (ADCHS ≠ 0b1011)

Flash 1FFFh	Bit 7	Bit 6	Bit 5	Bit 4	Bit 3	Bit 2	Bit 1	Bit 0
<b>CFGWH</b>	PROT	XRSTE	LVRE		VCCFLT	PWRSAB	MVCLOCK	-

1FFFh.3 **VCCFLT:** Set 1 to enhance the chip's power noise immunity

1FFFh.2 **PWRSAB:** Power saving function control bit

0: Disable Power saving function

1: Enable Power saving function

SFR 94h	Bit 7	Bit 6	Bit 5	Bit 4	Bit 3	Bit 2	Bit 1	Bit 0
<b>OPTION</b>	UART1W	MODE3V	WDTPSC		ADCKS		TM3PSC	
R/W	R/W	R/W	R/W		R/W		R/W	
Reset	0	0	0	0	0	0	0	0

94h.6 **MODE3V:** 3V mode selection control bit

If this bit is set, the chip can be only operated in the condition of  $V_{CC} < 3.6V$ , and LDO is turned off to save current

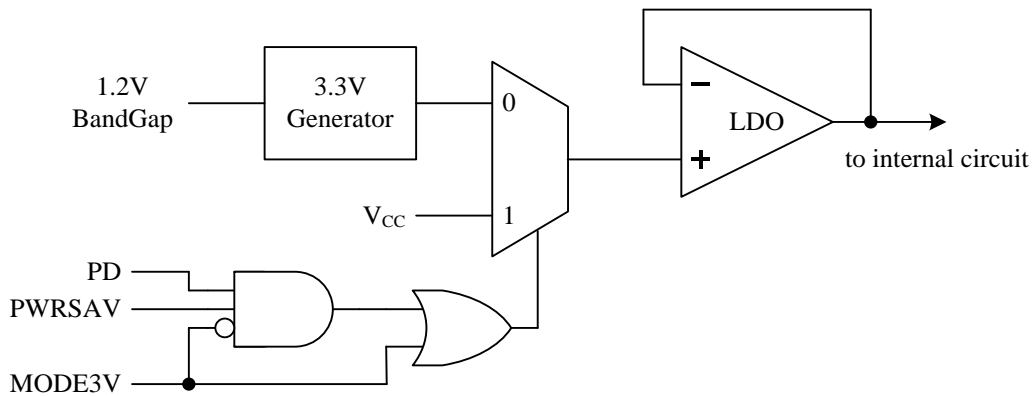



## 4. Reset

The Chip has five types of reset methods. Resets can be caused by Power on Reset (POR), External Pin Reset (XRST), Software Command Reset (SWRST), Watchdog Timer Reset (WDTR), or Low Voltage Reset (LVR). The CFGW controls the Reset functionality. The SFRs are returned to their default value after Reset.

### 4.1 Power on Reset

After Power on Reset, the device stays on Reset state for 40 ms as chip warm up time, then downloads the CFGW register from Flash's last two bytes (Other Reset will not reload the CFGW). The Power on Reset needs VCC pin's voltage first discharge to near VSS level, then rise beyond 2.0V.

### 4.2 External Pin Reset

External Pin Reset is active low. It needs to keep at least 2 SRC clock cycle long to be seen by the chip. External Pin Reset can be disabled or enabled by CFGW.

### 4.3 Software Command Reset

Software Reset is activated by writing the SFR 97h with data 56h.

### 4.4 Watchdog Timer Reset

WDT overflow Reset is disabled or enabled by SFR F7h. The WDT uses SRC as its counting time base. It runs in Fast/Slow mode and runs or stops in Idle/Stop mode. WDT overflow speed can be defined by WDTPSC SFR. WDT is cleared by device Reset or CLRWDT SFR bit.

### 4.5 Low Voltage Reset

The Chip offers three options for LVR and Low Voltage Detection (LVD) functions. The user can make a selection by CFGW, let LVR voltages of 2.9V, 2.3V, and 1.8V/2.0V be selected separately, and let LVD be 2.3V only. If the LVR is selected as 1.8V/2.0V, the 2.3V LVD flag is available for LVD. If LVR is selected as 2.3V or 2.9V, the LVD flag cannot be used.

System Clock frequency	8MHz	6MHz	4MHz	2MHz	1MHz
Minimum LVR level	LVR=2.9V	LVR=2.9V	LVR=2.3V	LVR=2.0V	LVR=1.8V/2.0V

**LVR setting table**

**Note:** LVR must be enable, also refer to AP-TM52XXXXX\_02S for LVR setting information

Flash <b>1FFEh</b>	Bit 7	Bit 6	Bit 5	Bit 4	Bit 3	Bit 2	Bit 1	Bit 0
<b>CFGWL</b>	WDTE		-	FRFCF				

1FFEh.7~6 **WDTE**: Watchdog Timer Reset control

0x: Watchdog Timer Reset disable

10: Watchdog Timer Reset enable in Fast/Slow mode, disable in Idle/Stop mode

11: Watchdog Timer Reset always enable

**Note**: FW should not change FRFCF while writing WDTE

Flash <b>1FFFh</b>	Bit 7	Bit 6	Bit 5	Bit 4	Bit 3	Bit 2	Bit 1	Bit 0
<b>CFGWH</b>	PROT	XRSTE	LVRE		VCCFLT	PWRSVAV	MVCLOCK	-

1FFFh.6 **XRSTE**: External Pin Reset control

0: Disable External Pin Reset

1: Enable External Pin Reset

1FFFh.5~4 **LVRE**: Low Voltage Reset function select

00: Set LVR at 2.9V

01: Set LVR at 2.3V

10: LVR disable and set LVD at 2.3V(F5264B/68B)

11: Set LVR at 1.8V and LVD at 2.3V(F5264B/68B)

1x: Set LVR at 2.0V and LVD at 2.3V (F5264C/68C)

SFR <b>94h</b>	Bit 7	Bit 6	Bit 5	Bit 4	Bit 3	Bit 2	Bit 1	Bit 0
<b>OPTION</b>	UART1W	MODE3V	WDTPSC		ADCKS		TM3PSC	
R/W	R/W	R/W	R/W		R/W		R/W	
Reset	0	0	0	0	0	0	0	0

94h.5~4 **WDTPSC**: Watchdog Timer pre-scalar time select

00: 360ms WDT overflow rate

01: 180ms WDT overflow rate

10: 90ms WDT overflow rate

11: 45ms WDT overflow rate

SFR <b>95h</b>	Bit 7	Bit 6	Bit 5	Bit 4	Bit 3	Bit 2	Bit 1	Bit 0
<b>INTFLG</b>	LVD	-	TKIF	ADIF	-	IE2	P1IF	TF3
R/W	R	-	R/W	R/W	-	R/W	R/W	R/W
Reset	-	-	0	0	-	0	0	0

95h.7 **LVD**: Low Voltage Detect flag

Set by H/W when a low voltage occurs. The flag is valid when LVR is 2.0V. This flag is disabled in Stop mode or if MODE3V=1 and PWRSVAV=1.

SFR <b>97h</b>	Bit 7	Bit 6	Bit 5	Bit 4	Bit 3	Bit 2	Bit 1	Bit 0
<b>SWCMD</b>	IAPALL/SWRST							
R/W	W							R/W
Reset	-							0

97h.7~0 **SWRST**: Write 56h to generate S/W Reset

SFR <b>F8h</b>	Bit 7	Bit 6	Bit 5	Bit 4	Bit 3	Bit 2	Bit 1	Bit 0
<b>AUX1</b>	CLRWDT	CLRTM3	TKSOC	ADSOC	CLRPWM0	-	-	DPSEL
R/W	R/W	R/W	R/W	R/W	R/W	-	-	R/W
Reset	0	0	0	0	0	-	-	0

F8h.7 **CLRWDT**: Set to clear WDT, H/W auto clear it at next clock cycle

## 5. Clock Circuitry and Operation Mode

### 5.1 System Clock

The Chip is designed with dual-clock system. During runtime, user can directly switch the System clock from fast to slow or from slow to fast. It also can directly select a clock divider of 1, 2, 4 or 16. The Fast clock can be selected as FXT (Fast Crystal, 1~8 MHz) or FRC (Fast Internal RC, 7.3728 MHz). The Slow clock can be selected as SXT (Slow Crystal, 32 KHz) or SRC (Slow Internal RC, 24 KHz). Fast mode and Slow mode are defined as the CPU running at Fast and Slow clock speeds.

After Reset, the device is running at Slow mode with 24 KHz SRC. S/W should select the proper clock rate for chip operation safety. The higher  $V_{CC}$  allows the chip to run at a higher System clock frequency. In a typical condition, an 8 MHz System clock rate requires  $V_{CC} > 2.5V$ .

The Chip has an external oscillators connected to the XI/XO pins. It relies on external circuitry for the clock signal and frequency stabilization, such as a stand-alone oscillator, quartz crystal, or ceramic resonator. In Fast mode, the fast oscillator can be used in the range from 1~8 MHz. In Slow mode, the slow oscillator can only use a clock frequency of 32.768 KHz.

The **CLKCON** SFR controls the System clock operating. H/W automatically blocks the S/W abnormally setting for this register. S/W can only change the Slow clock type in Fast mode and change the Fast clock type in Slow mode. Never to write both STPFCK=1 & SELFCK=1. It is recommended to write this SFR bit by bit.

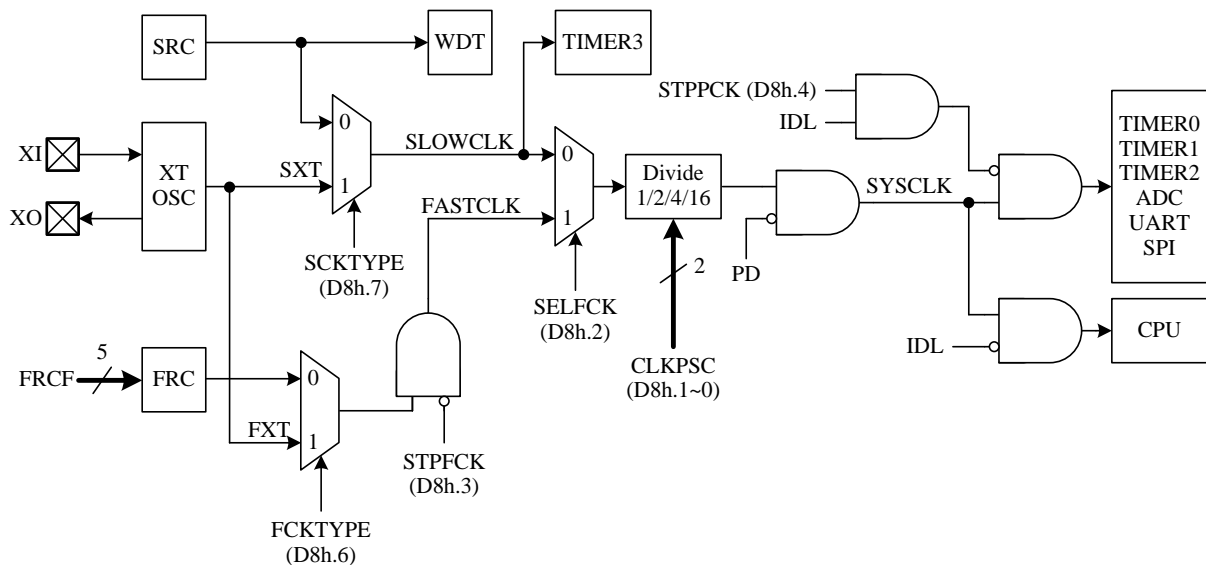

**Note:** also refer to AP-TM52XXXXX\_01S and AP-TM52XXXXX\_02S about System Clock Application Note.

## 5.2 Operation Mode

There are four operation modes for this device. **Fast Mode** is defined as the CPU running at Fast clock speed. **Slow Mode** is defined as the CPU running at Slow clock speed. When the System clock speed is lower, the power consumption is lower.

**Idle Mode** is entered by setting the IDL bit in PCON SFR. Both Fast and Slow clock can be set as the System clock source in Idle Mode, but Slow clock is better for power saving. In Idle mode, the CPU puts itself to sleep while the on-chip peripherals stay active. The “STPPCK” bit in CLKCON SFR can be set to furthermore reduce Idle mode current. If STPPCK=1, Timer0/1/2, ADC and UART are stopped in Idle mode. The slower System clock rate also helps current saving. It can be achieved by setup the CLKPSC SFR to divide System clock frequency. Idle mode is terminated by Reset or enabled Interrupts wake up.

**Stop Mode** is entered by setting the PD bit in PCON SFR. This mode is the so-called “Power Down” mode in standard 8051. In Stop mode, all clocks stop except the WDT is alive if it is enabled. Stop mode can be terminated by Reset or pin wake up.

**Note:** Chip cannot enter Stop Mode if INTn pin is low and wakeup is enabled. (INTn=0 and EXn=1, n=0,1,2)

SFR 87h	Bit 7	Bit 6	Bit 5	Bit 4	Bit 3	Bit 2	Bit 1	Bit 0
<b>PCON</b>	SMOD	–	–	–	GF1	GF0	PD	IDL
R/W	R/W	–	–	–	R/W	R/W	R/W	R/W
Reset	0	–	–	–	0	0	0	0

87h.1 **PD:** Stop bit. If 1 Stop mode is entered.

87h.0 **IDL:** Idle bit. If 1, Idle mode is entered.

SFR D8h	Bit 7	Bit 6	Bit 5	Bit 4	Bit 3	Bit 2	Bit 1	Bit 0
<b>CLKCON</b>	SCKTYPE	FCKTYPE	–	STPPCK	STPFCK	SELFCK	CLKPSC	
R/W	R/W	R/W	–	R/W	R/W	R/W	R/W	
Reset	0	0	–	0	0	0	1	1

D8h.7 **SCKTYPE:** Slow clock type. This bit can be changed only in Fast mode (SELFCK=1).

0: SRC

1: SXT

D8h.6 **FCKTYPE:** Fast clock type. This bit can be changed only in Slow mode (SELFCK=0).

0: FRC

1: FXT

D8h.4 **STPPCK:** Set 1 to stop UART/Timer0/Timer1/Timer2/ADC clock in Idle mode

D8h.3 **STPFCK:** Set 1 to stop Fast clock for power saving in Slow/Idle mode.

This bit can be changed only in Slow mode.

D8h.2 **SELFCK:** System clock source selection. This bit can be changed only when STPFCK=0.

0: Slow clock

1: Fast clock

D8h.1~0 **CLKPSC:** System clock prescaler.

00: System clock is Fast/Slow clock divided by 16

01: System clock is Fast/Slow clock divided by 4

10: System clock is Fast/Slow clock divided by 2

11: System clock is Fast/Slow clock divided by 1

## 6. Interrupt and Wake-up

This Chip has an 11-source four-level priority interrupt structure. All enabled Interrupts can wake up CPU from Idle mode, but only the Pin Interrupts can wake up CPU from Stop mode. Each interrupt source has its own enable control bit. An interrupt event will set its individual Interrupt Flag, no matter whether its interrupt enable control bit is 0 or 1. The Interrupt vectors and flags are list below.

Vector	Flag	Description
0003	IE0	INT0 external pin Interrupt (can wake up Stop mode)
000B	TF0	Timer0 Interrupt
0013	IE1	INT1 external pin Interrupt (can wake up Stop mode)
001B	TF1	Timer1 Interrupt
0023	RI+TI	Serial Port (UART) Interrupt
002B	TF2+EXF2	Timer2 Interrupt
0033	–	Reserved for ICE mode use
003B	TF3	Timer3 Interrupt
0043	P1IF	Port1 external pin change Interrupt (can wake up Stop mode)
004B	IE2	INT2 external pin Interrupt (can wake up Stop mode)
0053	ADIF+TKIF	ADC/Touch Key Interrupt
005B	SPIF+WCOL+MODF	SPI Interrupt

**Interrupt Vector & Flag**

### 6.1 Interrupt Enable and Priority Control

The IE and INTE1 SFRs decide whether the pending interrupt is serviced by CPU. The IP, IPH, IP1 and IP1H SFRs decide the interrupt priority. An interrupt will be serviced as long as an interrupt of equal or higher priority is not already being serviced. If an interrupt of equal or higher level priority is being serviced, the new interrupt will wait until it is finished before being serviced. If a lower priority level interrupt is being serviced, it will be stopped and the new interrupt serviced. When the new interrupt is finished, the lower priority level interrupt that was stopped will be completed.

SFR 96h	Bit 7	Bit 6	Bit 5	Bit 4	Bit 3	Bit 2	Bit 1	Bit 0
<b>P1WKUP</b>	P1WKUP							
R/W	R/W							
Reset	0	0	0	0	0	0	0	0

96h.7~0 **P1WKUP:** P1.7~P1.0 pin individual Wake up/Interrupt enable control

0: Disable

1: Enable

SFR A8h	Bit 7	Bit 6	Bit 5	Bit 4	Bit 3	Bit 2	Bit 1	Bit 0
<b>IE</b>	EA	–	ET2	ES	ET1	EX1	ET0	EX0
R/W	R/W	–	R/W	R/W	R/W	R/W	R/W	R/W
Reset	0	–	0	0	0	0	0	0

- A8h.7 **EA**: Global interrupt enable  
 0: Disable all interrupts  
 1: Each interrupt is enabled or disabled by its individual interrupt control bit
- A8h.5 **ET2**: Timer2 interrupt enable  
 0: Disable Timer2 interrupt  
 1: Enable Timer2 interrupt
- A8h.4 **ES**: Serial Port (UART) interrupt enable  
 0: Disable Serial Port (UART) interrupt  
 1: Enable Serial Port (UART) interrupt
- A8h.3 **ET1**: Timer1 interrupt enable  
 0: Disable Timer1 interrupt  
 1: Enable Timer1 interrupt
- A8h.2 **EX1**: INT1 pin Interrupt enable and Stop mode wake up enable  
 0: Disable INT1 pin Interrupt and Stop mode wake up  
 1: Enable INT1 pin Interrupt and Stop mode wake up, it can wake up CPU from Stop mode no matter EA is 0 or 1.
- A8h.1 **ET0**: Timer0 interrupt enable  
 0: Disable Timer0 interrupt  
 1: Enable Timer0 interrupt
- A8h.0 **EX0**: INT0 pin Interrupt enable and Stop mode wake up enable  
 0: Disable INT0 pin Interrupt and Stop mode wake up  
 1: Enable INT0 pin Interrupt and Stop mode wake up, it can wake up CPU from Stop mode no matter EA is 0 or 1.

SFR A9h	Bit 7	Bit 6	Bit 5	Bit 4	Bit 3	Bit 2	Bit 1	Bit 0
<b>INTE1</b>	IAPWE			SPIE	ADTKIE	EX2	P1IE	TM3IE
R/W	R/W			R/W	R/W	R/W	R/W	R/W
Reset	0	0	0	0	0	0	0	0

- A9h.4 **SPIE**: SPI interrupt enable  
 0: Disable SPI interrupt  
 1: Enable SPI interrupt
- A9h.3 **ADTKIE**: ADC/Touch Key (F5268 Only) interrupt enable  
 0: Disable ADC/Touch Key (F5268 Only) interrupt  
 1: Enable ADC/Touch Key (F5268 Only) interrupt
- A9h.2 **EX2**: INT2 pin Interrupt enable and Stop mode wake up enable  
 0: Disable INT2 pin Interrupt and Stop mode wake up  
 1: Enable INT2 pin Interrupt and Stop mode wake up, it can wake up CPU from Stop mode no matter EA is 0 or 1.
- A9h.1 **P1IE**: Port1 pin change interrupt enable  
 0: Disable Port1 pin change interrupt  
 1: Enable Port1 pin change interrupt
- A9h.0 **TM3IE**: Timer3 interrupt enable  
 0: Disable Timer3 interrupt  
 1: Enable Timer3 interrupt

SFR B9h	Bit 7	Bit 6	Bit 5	Bit 4	Bit 3	Bit 2	Bit 1	Bit 0
<b>IPH</b>	–	–	PT2H	PSH	PT1H	PX1H	PT0H	PX0H
R/W	–	–	R/W	R/W	R/W	R/W	R/W	R/W
Reset	–	–	0	0	0	0	0	0

SFR B8h	Bit 7	Bit 6	Bit 5	Bit 4	Bit 3	Bit 2	Bit 1	Bit 0
<b>IP</b>	–	–	PT2	PS	PT1	PX1	PT0	PX0
R/W	–	–	R/W	R/W	R/W	R/W	R/W	R/W
Reset	–	–	0	0	0	0	0	0

B9h.5, B8h.5 **PT2H, PT2**: Timer2 interrupt priority control. (PT2H, PT2) =

00: Level 0 (lowest priority)

01: Level 1

10: Level 2

11: Level 3 (highest priority)

B9h.4, B8h.4 **PSH, PS**: Serial Port (UART) interrupt priority control. Definition as above.

B9h.3, B8h.3 **PT1H, PT1**: Timer1 interrupt priority control. Definition as above.

B9h.2, B8h.2 **PX1H, PX1**: INT1 pin interrupt priority control. Definition as above.

B9h.1, B8h.1 **PT0H, PT0**: Timer0 interrupt priority control. Definition as above.

B9h.0, B8h.0 **PX0H, PX0**: INT0 pin interrupt priority control. Definition as above.

SFR BBh	Bit 7	Bit 6	Bit 5	Bit 4	Bit 3	Bit 2	Bit 1	Bit 0
<b>IP1H</b>	–	–	–	PSPIH	PADTKIH	PX2H	PP1H	PT3H
R/W	–	–	–	R/W	R/W	R/W	R/W	R/W
Reset	–	–	–	0	0	0	0	0

SFR BAh	Bit 7	Bit 6	Bit 5	Bit 4	Bit 3	Bit 2	Bit 1	Bit 0
<b>IP1</b>	–	–	–	PSPI	PADTKI	PX2	PP1	PT3
R/W	–	–	–	R/W	R/W	R/W	R/W	R/W
Reset	–	–	–	0	0	0	0	0

BBh.4, BAh.4 **PSPIH, PSPI**: SPI interrupt priority control. Definition as above.

BBh.3, BAh.3 **PADTKIH, PADTKI**: ADC/Touch Key (F5268 only) interrupt priority control. Definition as above.

BBh.2, BAh.2 **PX2H, PX2**: INT2 pin interrupt priority control. Definition as above.

BBh.1, BAh.1 **PP1H, PP1**: Port1 pin change interrupt priority control. Definition as above.

BBh.0, BAh.0 **PT3, PT3**: Timer3 interrupt priority control. Definition as above.

### 6.2 Pin Interrupt

Pin Interrupts include INT0 (P3.2), INT1 (P3.3), INT2 (P3.7) and Port1 Change Interrupt. These pins also have the Stop mode wake up capability. INT0 and INT1 are falling edge or low level triggered as the 8051 standard. INT2 is falling edge triggered and Port1 Change Interrupt is triggered by any Port1 pin state change.

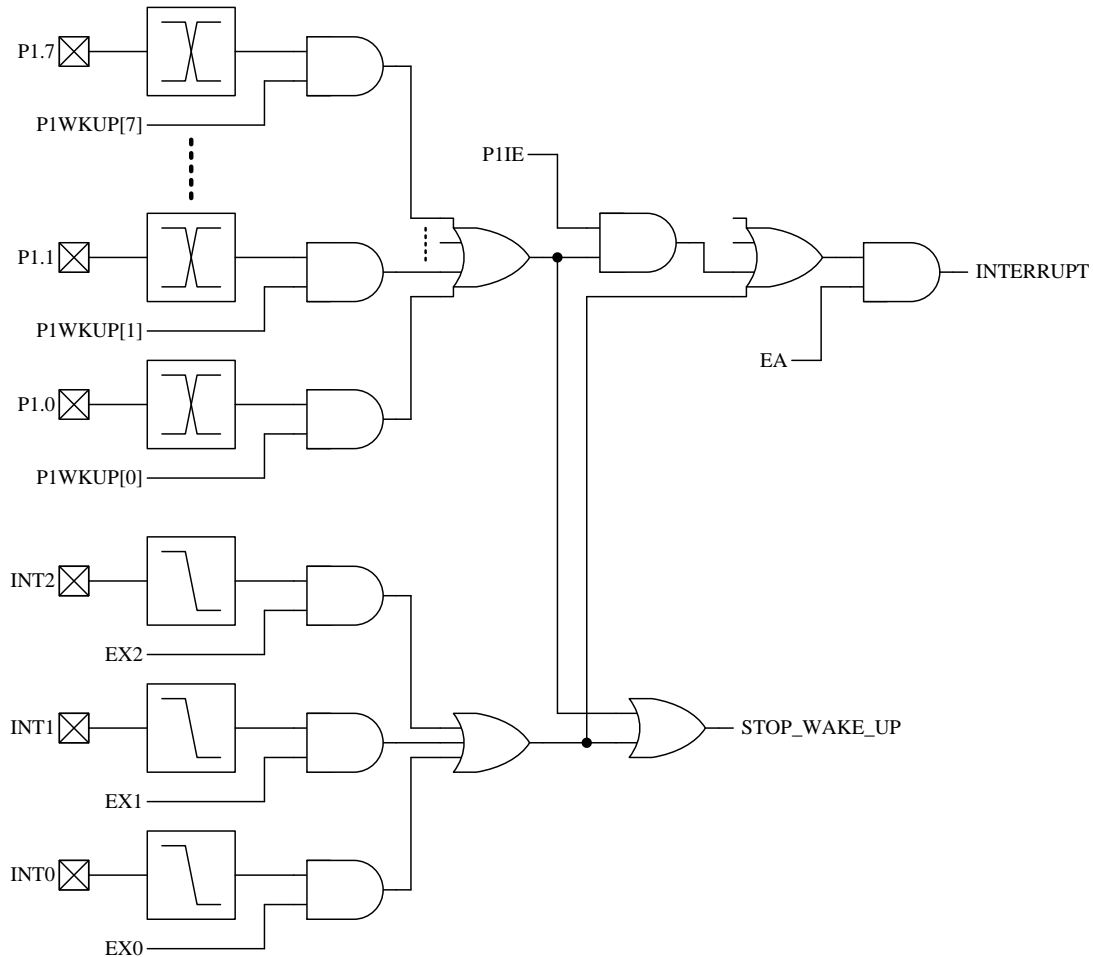

Pin Interrupt & Wake up

SFR 88h	Bit 7	Bit 6	Bit 5	Bit 4	Bit 3	Bit 2	Bit 1	Bit 0
<b>TCON</b>	TF1	TR1	TF0	TR0	IE1	IT1	IE0	IT0
R/W	R/W	R/W	R/W	R/W	R/W	R/W	R/W	R/W
Reset	0	0	0	0	0	0	0	0

- 88h.3 **IE1:** External Interrupt 1 (INT1 pin) edge flag  
Set by H/W when an INT1 pin falling edge is detected, no matter the EX1 is 0 or 1.  
It is cleared automatically when the program performs the interrupt service routine.
- 88h.2 **IT1:** External Interrupt 1 control bit  
0: Low level active (level triggered) for INT1 pin  
1: Falling edge active (edge triggered) for INT1 pin
- 88h.1 **IE0:** External Interrupt 0 (INT0 pin) edge flag  
Set by H/W when an INT0 pin falling edge is detected, no matter the EX0 is 0 or 1.  
It is cleared automatically when the program performs the interrupt service routine.
- 88h.0 **IT0:** External Interrupt 0 control bit  
0: Low level active (level triggered) for INT0 pin  
1: Falling edge active (edge triggered) for INT0 pin



SFR 95h	Bit 7	Bit 6	Bit 5	Bit 4	Bit 3	Bit 2	Bit 1	Bit 0
<b>INTFLG</b>	LVD	–	TKIF	ADIF	–	IE2	P1IF	TF3
R/W	R	–	R/W	R/W	–	R/W	R/W	R/W
Reset	–	–	0	0	–	0	0	0

95h.2 **IE2:** External Interrupt 2 (INT2 pin) edge flag

Set by H/W when a falling edge is detected on the INT2 pin state, no matter the EX2 is 0 or 1.

It is cleared automatically when the program performs the interrupt service routine.

S/W can write FBh to INTFLG to clear this bit. (Note2)

95h.1 **P1IF:** Port1 pin change interrupt flag

Set by H/W when a P1 pin state change is detected, and its interrupt enable bit is set (P1WKUP).

P1IE does not affect this flag's setting.

It is cleared automatically when the program performs the interrupt service routine.

S/W can write FDh to INTFLG to clear this bit. (Note2)

**Note2:** S/W can write 0 to clear a flag in the INTFLG, but writing 1 has no effect.

### 6.3 Idle Mode Wake up and Interrupt

Idle mode is waked up by enabled Interrupts, which means individual interrupt enable bit (ex: EX0) and EA bit must be both set to 1 to establish Idle mode wake up capability. All enabled Interrupts (Pins, Timers, ADC, TK, SPI and UART) can wake up CPU from Idle mode. Upon Idle wake-up, Interrupt service routine is entered immediately. “The first instruction behind IDL (PCON.0) setting” is executed after interrupt service routine return.

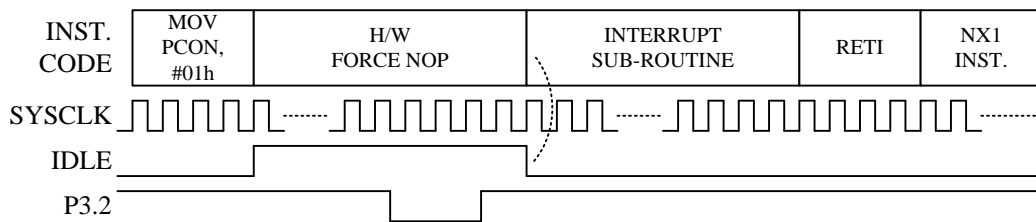

**EA=EX0=1, Idle mode wake-up and Interrupt by P3.2 (INT0)**

SFR 87h	Bit 7	Bit 6	Bit 5	Bit 4	Bit 3	Bit 2	Bit 1	Bit 0
<b>PCON</b>	SMOD	–	–	–	GF1	GF0	PD	IDL
R/W	R/W	–	–	–	R/W	R/W	R/W	R/W
Reset	0	–	–	–	0	0	0	0

87h.1 **PD:** Stop bit. If 1, Stop mode is entered.

87h.0 **IDL:** Idle bit. If 1, Idle mode is entered.

### 6.4 Stop Mode Wake up and Interrupt

Stop mode wake up is simple, as long as the individual pin interrupt enable bit (ex: EX0) is set, the pin wake up capability is asserted. Set EX0/EX1/EX2 can enable INT0/INT1/INT2 pins' Stop mode wake up capability. Set P1WKUP bit 7~0 can enable P1.7~P1.0's Stop mode wake up capability. Upon Stop wake up, “the first instruction behind PD (PCON.1) setting” is executed immediately before Interrupt service. Interrupt entry needs EA=1 (P1WKUP also needs P1IE=1) and the trigger state of the pin staying sufficiently long to be observed by the System clock. This feature allows CPU to enter or not enter Interrupt sub-routine after Stop mode wake up.

**Note:** Chip cannot enter Stop Mode if INTn pin is low and wakeup is enabled. (INTn=0 and EXn=1, n=0,1,2)

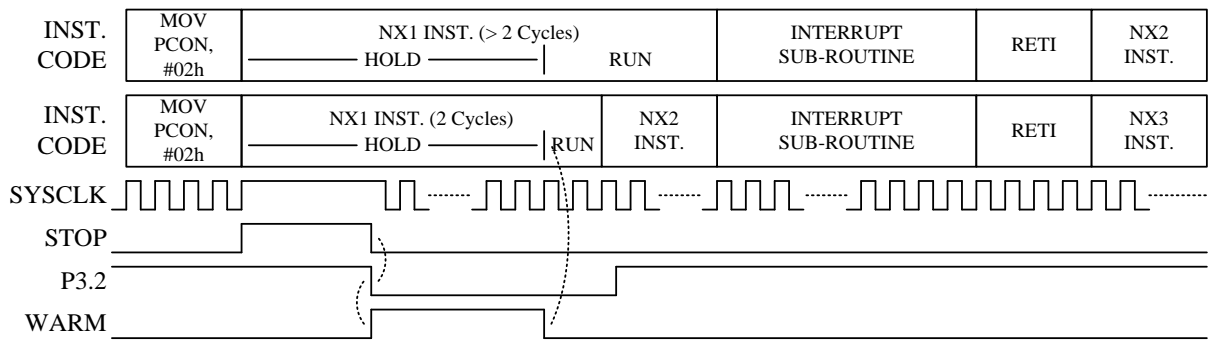

**EA=EX0=1**

**P3.2 (INT0) is sampled after warm-up, Stop mode wake-up and Interrupt.**

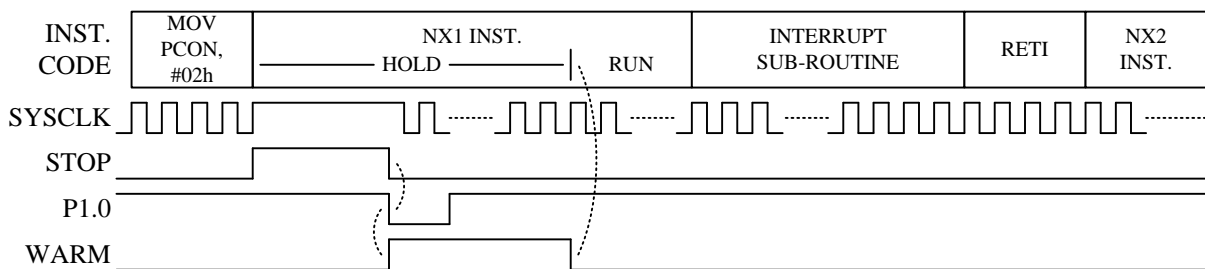

**EA=P1IE=P1WKUP=1**

**P1.0 change (not need clock sample), Stop mode wake-up and Interrupt.**

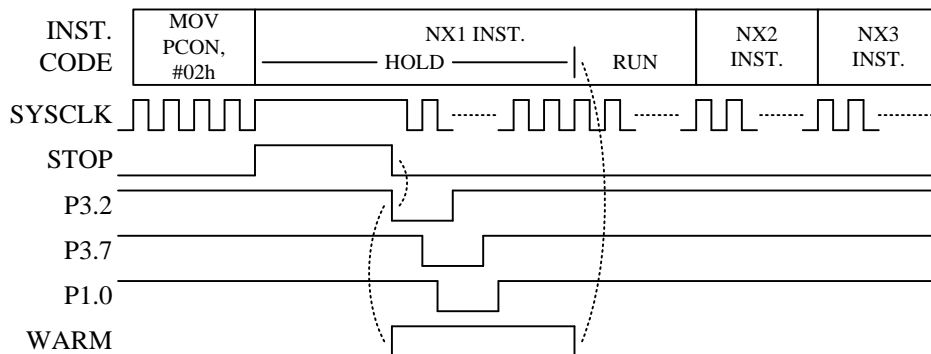

**EA=EX0=EX2=P1WKUP=1, P1IE=0**

**Stop mode wake-up but not Interrupt, P3.2/P3.7 pulse too narrow.**

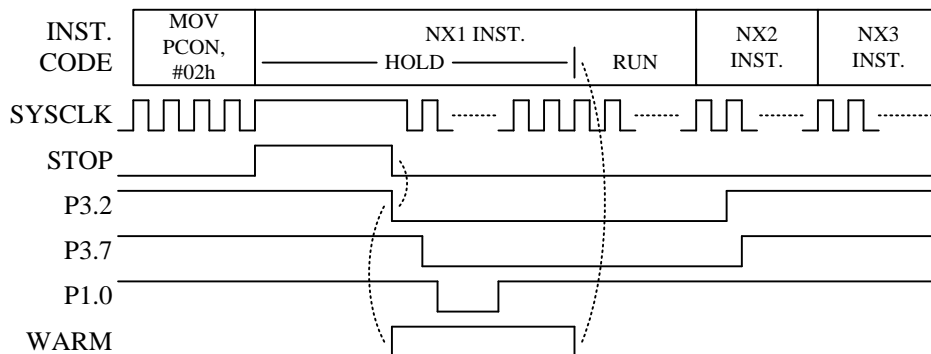

**EX0=EX2=P1WKUP=1=P1IE=1, EA=0**

**Stop mode wake-up but not Interrupt.**

## 7. I/O Ports

The Chip has total 22 multi-function I/O pins. All I/O pins follow the standard 8051 “Read-Modify-Write” feature. The instructions that read the SFR rather than the Pin State are the ones that read a port or port bit value, possibly change it, and then rewrite it to the SFR. (ex: ANL P1, A; INC P2; CPL P3.0)

### 7.1 Port1 & P2.1~P2.0 & P3.6~P3.0

These pins can operate in four different modes as below.

Mode	Port1, P2.1~P2.0, P3.6~P3.0 pin function		Px.n SFR data	Pin State	Resistor Pull-up	Digital Input
	P3.2~P3.0	Others				
<b>Mode 0</b>	Pseudo Open Drain	Open Drain	0	Drive Low	N	N
			1	Pull-up	Y	Y
<b>Mode 1</b>	Pseudo Open Drain	Open Drain	0	Drive Low	N	N
			1	Hi-Z	N	Y
<b>Mode 2</b>	CMOS Output		0	Drive Low	N	N
			1	Drive High	N	N
<b>Mode 3</b>	Alternative Function, such as ADC and Touch Key		X (don't care)	—	N	N

**Port1, P2.1~P2.0, P3.6~P3.0 I/O Pin Function Table**

If a Port1, P2.1~P2.0 or P3.6~P3.0 pin is used for Schmitt-trigger input, S/W must set the I/O pin to Mode0 or Mode1 and set the corresponding Port Data SFR to 1 to disable the pin’s output driving circuitry.

Beside I/O port function, each Port1, P2.1~P2.0 and P3.6~P3.0 pin has one or more alternative functions, such as ADC and Touch Key. Most of the functions are activated by setting the individual pin mode control SFR to Mode3. Port1/Port3 pins have standard 8051 auxiliary definition such as INT0/1, T0/1/2, or RXD/TXD. These pin functions need to set the pin mode SFR to Mode0 or Mode1 and keep the P1.n/P3.n SFR at 1.

Pin Name	8051	Wake-up	CKO	ADC/TK	others	Mode3
P1.0	T2	Y	T2O	AD4/TK0		AD4/TK0
P1.1	T2EX	Y		AD5/TK1		AD5/TK1
P1.2		Y		AD6/TK2	PWM0	AD6/TK2
P1.3		Y		AD7/TK3	PWM1	AD7/TK3
P1.4		Y	CKO	AD8/TK8		AD8/TK8
P1.5		Y		AD9/CLD		AD9/CLD
P1.6		Y		TK9		TK9
P1.7		Y		TK10	MISO	TK10
P3.0	RXD			AD3/TK7		AD3/TK7
P3.1	TXD			AD2/TK6		AD2/TK6
P3.2	INT0	Y		AD1/TK5		AD1/TK5
P3.3	INT1	Y		AD0/TK4		AD0/TK4
P3.4	T0		T0O	TK13	SS	TK13
P3.5	T1			TK12	MOSI	TK12
P3.6				TK11	SCK	TK11
P2.0					XI	
P2.1					XO	

**Port1, P2.1~P2.0, P3.6~P3.0 multi-function Table**

The necessary SFR setting for Port1/P2.1~P2.0/P3.6~P3.0 pin's alternative function is list below.

Alternative Function	Mode	Px.n SFR data	Pin State	Other necessary SFR setting
T0, T1, T2, T2EX, INT0, INT1	0	1	Input with Pull-up	
	1	1	Input	
RXD, TXD	0	1	Input with Pull-up/Pseudo Open Drain Output	
	1	1	Input/Pseudo Open Drain Output	
T00, T20, CKO	0	X	Clock Open Drain Output with Pull-up	PINMOD P3MODH
	1	X	Clock Open Drain Output	
	2	X	Clock Output (CMOS Push-Pull)	
TK0~TK13	0	1	Touch Key Idling, Pull-up	
	3	X	Touch Key Scanning	
CLD	3	X	Touch Key Capacitor Connection	
AD0~AD9	3	X	ADC Channel	
PWM0, PWM1	0	X	PWM Open Drain Output with Pull-up	PINMOD
	1	X	PWM Open Drain Output	
	2	X	PWM Output (CMOS Push-Pull)	
SPI Master Mode MISO	1	1	SPI Data Input	SPCON
SPI Master Mode SCK, MOSI	2	X	SPI Clock/Data Output (CMOS Push-Pull)	SPCON
SPI Slave Mode MISO	2	X	SPI Data Output (CMOS Push-Pull)	SPCON
SPI Slave Mode SCK, MOSI	1	1	SPI Clock/Data Input	SPCON
SS	1	1	SPI Chip Selection	SPCON
XI, XO	0	1	Crystal oscillation	CLKCON

**Mode Setting for Port1, P2.1~P2.0, P3.6~P3.0 Alternative Function**

For tables above, a **“COMS Output”** pin means it can sink and drive at least 4 mA current. It is not recommended to use such pin as input function.

An **“Open Drain”** pin means it can sink at least 4 mA current but only drive a small current (<20μA). It can be used as input or output function and typically needs an external pull up resistor.

An 8051 standard pin is a **“Pseudo Open Drain”** pin. It can sink at least 4 mA current when output is at low level, and drives at least 4 mA current for 1~2 clock cycle when output transits from low to high, then keeps driving a small current (<20μA) to maintain the pin at high level. It can be used as input or output function.

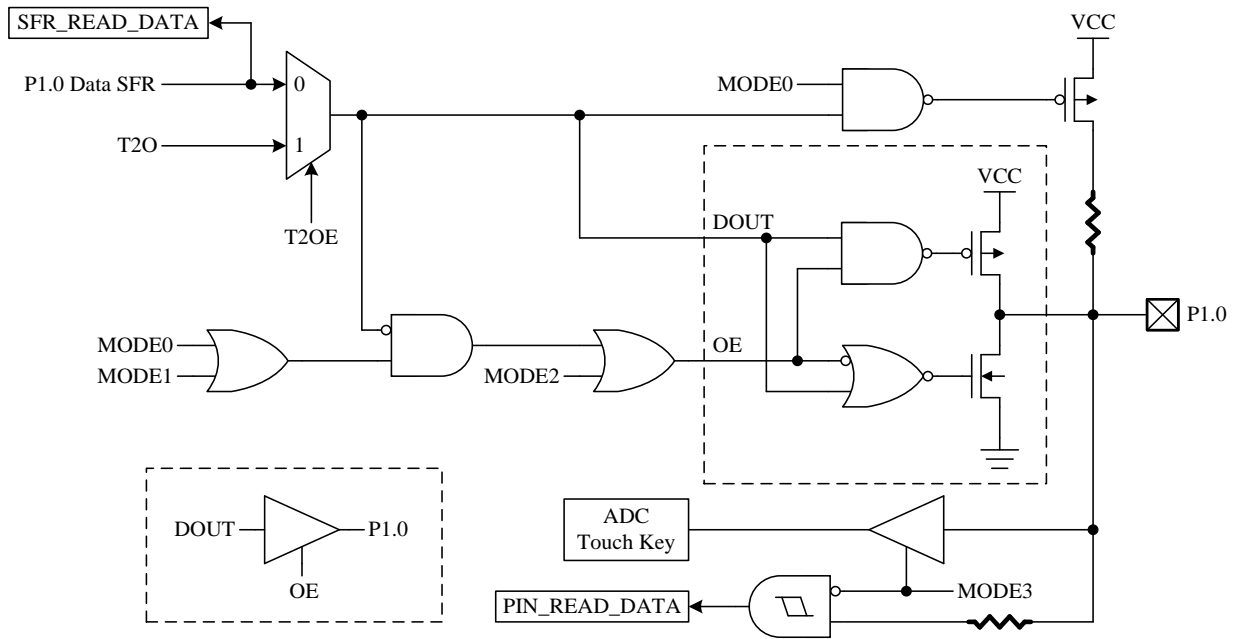

**P1.0 Pin Structure**

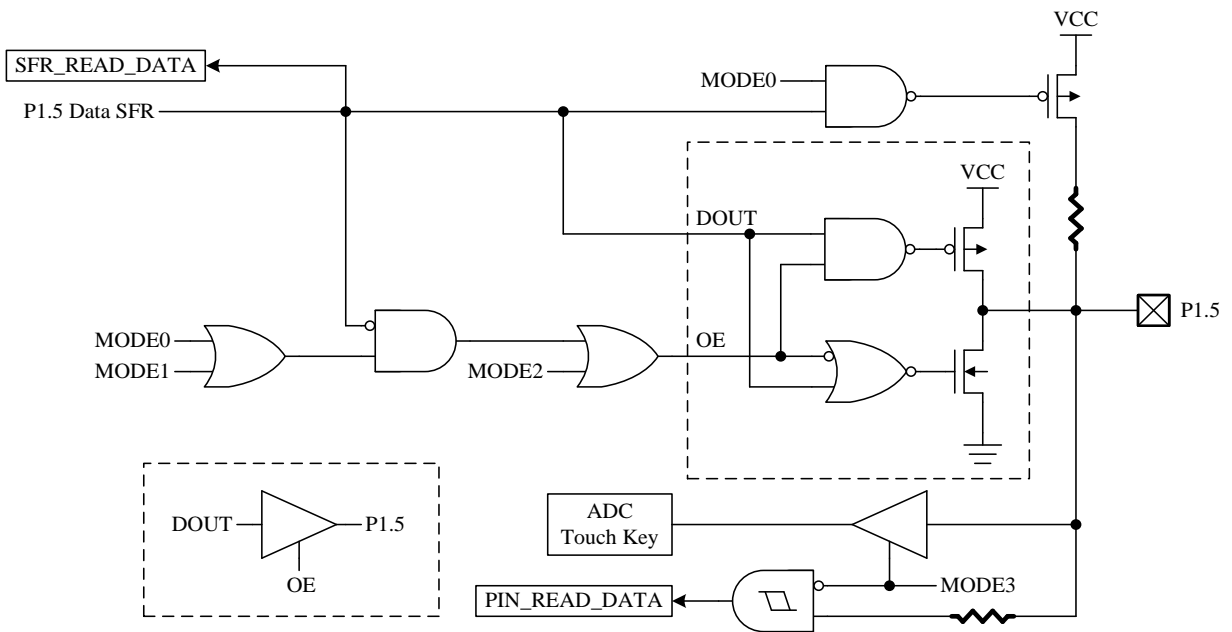

**P1.5 Pin Structure**

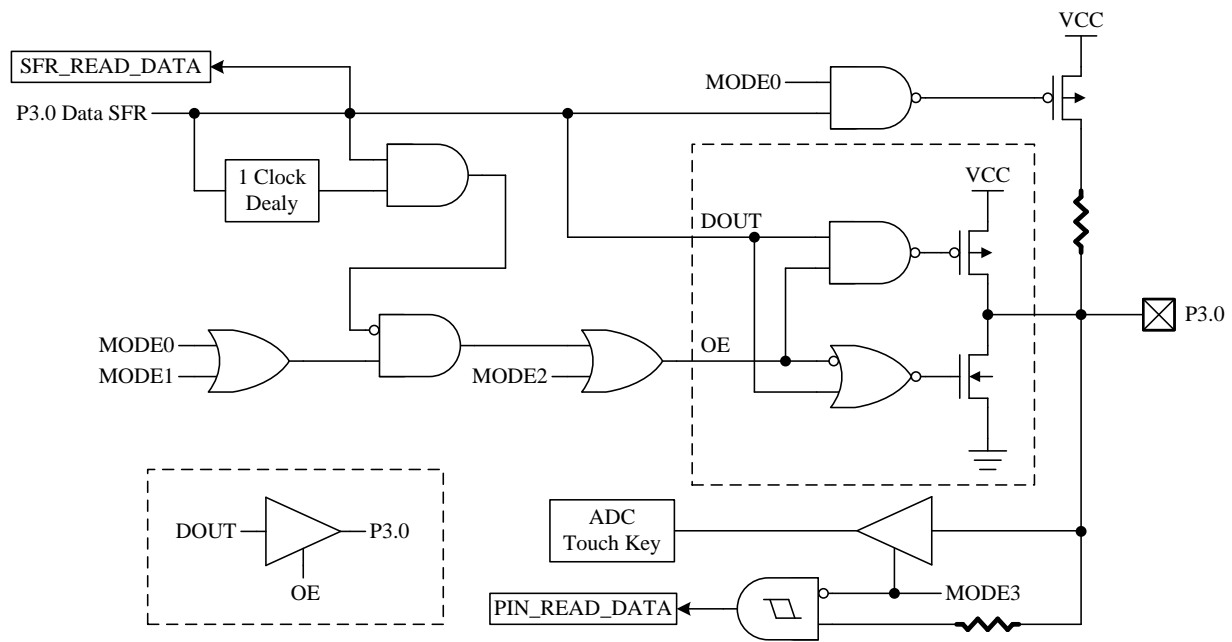

**P3.0 Pin Structure**

SFR 90h	Bit 7	Bit 6	Bit 5	Bit 4	Bit 3	Bit 2	Bit 1	Bit 0
<b>P1</b>	P1.7	P1.6	P1.5	P1.4	P1.3	P1.2	P1.1	P1.0
R/W	R/W	R/W	R/W	R/W	R/W	R/W	R/W	R/W
Reset	1	1	1	1	1	1	1	1

90h.7~0 **P1:** Port1 data

SFR B0h	Bit 7	Bit 6	Bit 5	Bit 4	Bit 3	Bit 2	Bit 1	Bit 0
<b>P3</b>	P3.7	P3.6	P3.5	P3.4	P3.3	P3.2	P3.1	P3.0
R/W	R/W	R/W	R/W	R/W	R/W	R/W	R/W	R/W
Reset	1	1	1	1	1	1	1	1

B0h.6~0 **P3.6~P3.0:** P3.6~P3.0 data

SFR A0h	Bit 7	Bit 6	Bit 5	Bit 4	Bit 3	Bit 2	Bit 1	Bit 0
<b>P2</b>	P2.7	P2.6	P2.5	P2.4	P2.3	P2.2	P2.1	P2.0
R/W	R/W	R/W	R/W	R/W	R/W	R/W	R/W	R/W
Reset	1	1	1	1	1	1	1	1

A0h.1~0 **P2.1~P2.0:** P2.1~P2.0 data

SFR A2h	Bit 7	Bit 6	Bit 5	Bit 4	Bit 3	Bit 2	Bit 1	Bit 0
<b>P1MODL</b>	P1MOD3		P1MOD2		P1MOD1		P1MOD0	
R/W	R/W		R/W		R/W		R/W	
Reset	0	0	0	0	0	0	0	0

- A2h.7~6 **P1MOD3**: P1.3 pin control  
 00: Mode0  
 01: Mode1  
 10: Mode2  
 11: Mode3, P1.3 is ADC or Touch Key input
- A2h.5~4 **P1MOD2**: P1.2 pin control  
 00: Mode0  
 01: Mode1  
 10: Mode2  
 11: Mode3, P1.2 is ADC or Touch Key input
- A2h.3~2 **P1MOD1**: P1.1 pin control  
 00: Mode0  
 01: Mode1  
 10: Mode2  
 11: Mode3, P1.1 is ADC or Touch Key input
- A2h.1~0 **P1MOD0**: P1.0 pin control  
 00: Mode0  
 01: Mode1  
 10: Mode2  
 11: Mode3, P1.0 is ADC or Touch Key input

SFR A3h	Bit 7	Bit 6	Bit 5	Bit 4	Bit 3	Bit 2	Bit 1	Bit 0
<b>P1MODH</b>	P1MOD7		P1MOD6		P1MOD5		P1MOD4	
R/W	R/W		R/W		R/W		R/W	
Reset	0	0	0	0	0	0	0	0

- A3h.7~6 **P1MOD7**: P1.7 pin control  
 00: Mode0  
 01: Mode1  
 10: Mode2  
 11: Mode3, P1.7 is Touch Key input
- A3h.5~4 **P1MOD6**: P1.6 pin control  
 00: Mode0  
 01: Mode1  
 10: Mode2  
 11: Mode3, P1.6 is Touch Key input
- A3h.3~2 **P1MOD5**: P1.5 pin control  
 00: Mode0  
 01: Mode1  
 10: Mode2  
 11: Mode3, P1.5 is ADC input or Touch Key CLD functional pin
- A3h.1~0 **P1MOD4**: P1.4 pin control  
 00: Mode0  
 01: Mode1  
 10: Mode2  
 11: Mode3, P1.4 is ADC or Touch Key input

SFR A4h	Bit 7	Bit 6	Bit 5	Bit 4	Bit 3	Bit 2	Bit 1	Bit 0
<b>P3MODL</b>	P3MOD3		P3MOD2		P3MOD1		P3MOD0	
R/W	R/W		R/W		R/W		R/W	
Reset	0	1	0	1	0	1	0	1

- A4h.7~6 **P3MOD3**: P3.3 pin control  
 00: Mode0  
 01: Mode1  
 10: Mode2  
 11: Mode3, P3.3 is ADC or Touch Key input
- A4h.5~4 **P3MOD2**: P3.2 pin control  
 00: Mode0  
 01: Mode1  
 10: Mode2  
 11: Mode3, P3.2 is ADC or Touch Key input
- A4h.3~2 **P3MOD1**: P3.1 pin control  
 00: Mode0  
 01: Mode1  
 10: Mode2  
 11: Mode3, P3.1 is ADC or Touch Key input
- A4h.1~0 **P3MOD0**: P3.0 pin control  
 00: Mode0  
 01: Mode1  
 10: Mode2  
 11: Mode3, P3.0 is ADC or Touch Key input

SFR A5h	Bit 7	Bit 6	Bit 5	Bit 4	Bit 3	Bit 2	Bit 1	Bit 0
<b>P3MODH</b>	T0OE	–	P3MOD6		P3MOD5		P3MOD4	
R/W	R/W	–	R/W		R/W		R/W	
Reset	0	–	0	0	0	0	0	0

- A5h.7 **T0OE**: Timer0 signal output (T0O) control  
 0: Disable Timer0 overflow divided by 64 output to P3.4  
 1: Enable Timer0 overflow divided by 64 output to P3.4
- A5h.5~4 **P3MOD6**: P3.6 pin control  
 00: Mode0  
 01: Mode1  
 10: Mode2  
 11: Mode3, P3.6 is Touch Key input
- A5h.3~2 **P3MOD5**: P3.5 pin control  
 00: Mode0  
 01: Mode1  
 10: Mode2  
 11: Mode3, P3.5 is Touch Key input
- A5h.1~0 **P3MOD4**: P3.4 pin control  
 00: Mode0  
 01: Mode1  
 10: Mode2  
 11: Mode3, P3.4 is Touch Key input



SFR 93h	Bit 7	Bit 6	Bit 5	Bit 4	Bit 3	Bit 2	Bit 1	Bit 0
<b>P2MOD</b>	–	–	–	–	P2MOD1		P2MOD0	
R/W	–	–	–	–	R/W		R/W	
Reset	–	–	–	–	0	1	0	1

93h.3~2 **P2MOD1**: P2.1 pin control

00: Mode0  
01: Mode1  
10: Mode2  
11: not defined

93h.1~0 **P2MOD0**: P2.0 pin control

00: Mode0  
01: Mode1  
10: Mode2  
11: not defined

SFR A6h	Bit 7	Bit 6	Bit 5	Bit 4	Bit 3	Bit 2	Bit 1	Bit 0
<b>PINMOD</b>	PWM1OE	–	PWM0OE	–	TCOE	T2OE	–	–
R/W	R/W	–	R/W	–	R/W	R/W	–	–
Reset	0	–	0	–	0	0	–	–

A6h.7 **PWM1OE**: PWM1 signal output enable

0: Disable PWM1 signal output to P1.3  
1: Enable PWM1 signal output to P1.3

A6h.5 **PWM0OE**: PWM0 signal output enable

0: Disable PWM0 signal output to P1.2  
1: Enable PWM0 signal output to P1.2

A6h.3 **TCOE**: System clock signal output (CKO) control

0: Disable System clock divided by 2 output to P1.4  
1: Enable System clock divided by 2 output to P1.4

A6h.2 **T2OE**: Timer2 signal output (T2O) control

0: Disable Timer2 overflow divided by 2 output to P1.0  
1: Enable Timer2 overflow divided by 2 output to P1.0

SFR D8h	Bit 7	Bit 6	Bit 5	Bit 4	Bit 3	Bit 2	Bit 1	Bit 0
<b>CLKCON</b>	SCKTYPE	FCKTYPE	–	STPPCK	STPFCK	SELFCK	CLKPSC	
R/W	R/W	R/W	–	R/W	R/W	R/W	R/W	
Reset	0	0	–	0	0	0	1	1

D8h.7 **SCKTYPE**: Slow clock type. This bit can be changed only in Fast mode (SELFCK=1).

0: SRC, P2.1~P2.0 are I/O pins  
1: SXT, P2.1~P2.0 are crystal pins

D8h.6 **FCKTYPE**: Fast clock type. This bit can be changed only in Slow mode (SELFCK=0).

0: FRC, P2.1~P2.0 are I/O pins  
1: FXT, P2.1~P2.0 are crystal pins

SFR BCh	Bit 7	Bit 6	Bit 5	Bit 4	Bit 3	Bit 2	Bit 1	Bit 0
<b>SPCON</b>	SPEN	MSTR	CPOL	CPHA	SSDIS	LSBF	SPCR	
R/W	R/W	R/W	R/W	R/W	R/W	R/W	R/W	
Reset	0	0	0	0	0	0	0	0

BCh.7 **SPEN**: SPI enable

0: SPI disable  
1: SPI enable, P1.7, P3.5, P3.6 are SPI functional pins.

BCh.3 **SSDIS**: SS pin disable

0: Enable SS pin, P3.4 is SPI chip selection input.  
1: Disable SS pin

7.2 P3.7

P3.7 can be only used as Schmitt-trigger input or open-drain output, with pull-up resistor always enable. P3.7 pin is shared with RSTn, INT2 and Flash VPP function.

7.3 P0.3~P0.0

If a P0.3~P0.0 is defined as I/O pin, it can be used as CMOS push-pull output or Schmitt-trigger input. The pin's pull up function is enable while SFR bit PxOE.n=0 and Px.n=1.

P0.3~P0.0 pin function	PxOE.n	Px.n SFR data	Pin State	Resistor Pull-up	Digital Input
Input	0	0	Hi-Z	N	Y
	0	1	Pull-up	Y	Y
CMOS Output	1	0	Drive Low	N	N
	1	1	Drive High	N	N

P0.3~P0.0 I/O Pin Function Table

Pin Name	Wake-up	Others
P0.0		
P0.1		
P0.2		
P0.3		
P3.7	Y	INT2, RSTn, VPP

P0.3~P0.0, P3.7 multi-function Table

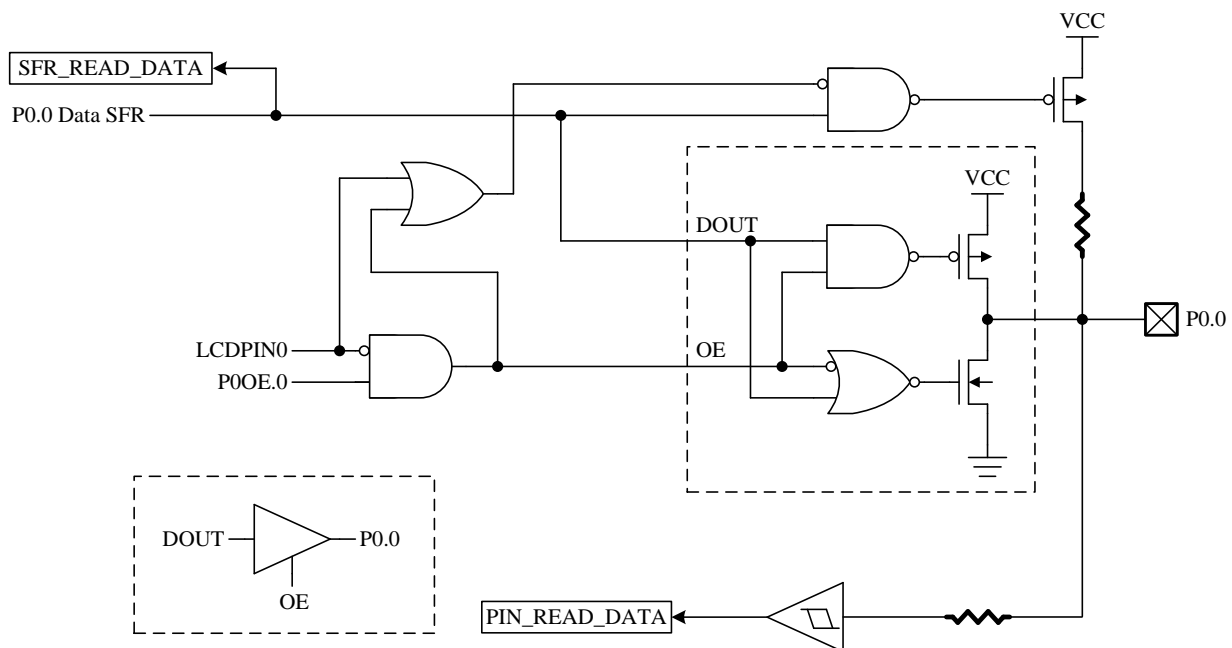

P0.0 Pin Structure

SFR 80h	Bit 7	Bit 6	Bit 5	Bit 4	Bit 3	Bit 2	Bit 1	Bit 0
<b>P0</b>	P0.7	P0.6	P0.5	P0.4	P0.3	P0.2	P0.1	P0.0
R/W	R/W	R/W	R/W	R/W	R/W	R/W	R/W	R/W
Reset	1	1	1	1	1	1	1	1

80h.3~0 **P0.3~P0.0:** P0.3~P0.0 data, also controls the P0.n pin's pull-up function. If the P0.n SFR data is "1" and the corresponding P0OE.n=0 (input mode), the pull-up is enabled.

SFR B0h	Bit 7	Bit 6	Bit 5	Bit 4	Bit 3	Bit 2	Bit 1	Bit 0
<b>P3</b>	P3.7	P3.6	P3.5	P3.4	P3.3	P3.2	P3.1	P3.0
R/W	R/W	R/W	R/W	R/W	R/W	R/W	R/W	R/W
Reset	1	1	1	1	1	1	1	1

B0h.7 **P3.7:** P3.7 data, also controls the P3.7 pin's I/O mode. If the P3.7 SFR data is "1", the P3.7 is assigned as Schmitt-trigger input mode; otherwise, it is assigned as open-drain output mode.

SFR 91h	Bit 7	Bit 6	Bit 5	Bit 4	Bit 3	Bit 2	Bit 1	Bit 0
<b>P0OE</b>	-	-	-	-	P0OE			
R/W	-	-	-	-	R/W			
Reset	-	-	-	-	0	0	0	0

91h.3~0 **P0OE:** P0.3~P0.0 CMOS Push-Pull output enable control  
 0: Disable  
 1: Enable

## 8. Timers

Timer0, Timer1 and Timer2 are provided as standard 8051 compatible timer/counter. Compare to the traditional 12T 8051, the chip's Timer0/1/2 use 2 System clock cycle as the time base unit. That is, in timer mode, these timers increase at every “2 System clock” rate; in counter mode, T0/T1/T2 pin input pulse must be wider than 2 System clock to be seen by this device. In addition to the standard 8051 timers function. The T0O pin can output the “Timer0 overflow divided by 64” signal, and the T2O pin can output the “Timer2 overflow divided by 2” signal. Timer3 is provided for a real-time clock count, when its time base is SXT.

### 8.1 Timer0/1

TCON and TMOD are used to set the mode of operation and to control the running and interrupt generation of the Timer0/1, with the timer/counter values stored in two pairs of 8-bit registers (TL0, TH0, and TL1, TH1).

SFR 88h	Bit 7	Bit 6	Bit 5	Bit 4	Bit 3	Bit 2	Bit 1	Bit 0
<b>TCON</b>	TF1	TR1	TF0	TR0	IE1	IT1	IE0	IT0
R/W	R/W	R/W	R/W	R/W	R/W	R/W	R/W	R/W
Reset	0	0	0	0	0	0	0	0

- 88h.7 **TF1:** Timer1 overflow flag  
Set by H/W when Timer/Counter 1 overflows.  
Cleared by H/W when CPU vectors into the interrupt service routine.
- 88h.6 **TR1:** Timer1 run control  
0: Timer1 stops  
1: Timer1 runs
- 88h.5 **TF0:** Timer0 overflow flag  
Set by H/W when Timer/Counter 0 overflows.  
Cleared by H/W when CPU vectors into the interrupt service routine.
- 88h.4 **TR0:** Timer0 run control  
0: Timer0 stops  
1: Timer0 runs

SFR 89h	Bit 7	Bit 6	Bit 5	Bit 4	Bit 3	Bit 2	Bit 1	Bit 0
<b>TMOD</b>	GATE1	CT1N	TMOD1		GATE0	CT0N	TMOD0	
R/W	R/W	R/W	R/W		R/W	R/W	R/W	
Reset	0	0	0	0	0	0	0	0

- 89h.7 **GATE1:** Timer1 gating control bit  
0: Timer1 enable when TR1 bit is set  
1: Timer1 enable only while the INT1 pin is high and TR1 bit is set
- 89h.6 **CT1N:** Timer1 Counter/Timer select bit  
0: Timer mode, Timer1 data increases at 2 System clock cycle rate  
1: Counter mode, Timer1 data increases at T1 pin's negative edge
- 89h.5~4 **TMOD1:** Timer1 mode select  
00: 8-bit timer/counter (TH1) and 5-bit prescaler (TL1)  
01: 16-bit timer/counter  
10: 8-bit auto-reload timer/counter (TL1). Reloaded from TH1 at overflow.  
11: Timer1 stops
- 89h.3 **GATE0:** Timer0 gating control bit  
0: Timer0 enable when TR0 bit is set  
1: Timer0 enable only while the INT0 pin is high and TR0 bit is set
- 89h.2 **CT0N:** Timer0 Counter/Timer select bit  
0: Timer mode, Timer0 data increases at 2 System clock cycle rate  
1: Counter mode, Timer0 data increases at T0 pin's negative edge

- 89h.1~0 **TMOD0:** Timer0 mode select  
 00: 8-bit timer/counter (TH0) and 5-bit prescaler (TL0)  
 01: 16-bit timer/counter  
 10: 8-bit auto-reload timer/counter (TL0). Reloaded from TH0 at overflow.  
 11: TL0 is an 8-bit timer/counter. TH0 is an 8-bit timer/counter using Timer1's TR1 and TF1 bits.

SFR 8Ah	Bit 7	Bit 6	Bit 5	Bit 4	Bit 3	Bit 2	Bit 1	Bit 0
<b>TL0</b>	TL0							
R/W	R/W							
Reset	0	0	0	0	0	0	0	0

8Ah.7~0 **TL0:** Timer0 data low byte

SFR 8Bh	Bit 7	Bit 6	Bit 5	Bit 4	Bit 3	Bit 2	Bit 1	Bit 0
<b>TL1</b>	TL1							
R/W	R/W							
Reset	0	0	0	0	0	0	0	0

8Bh.7~0 **TL1:** Timer1 data low byte

SFR 8Ch	Bit 7	Bit 6	Bit 5	Bit 4	Bit 3	Bit 2	Bit 1	Bit 0
<b>TH0</b>	TH0							
R/W	R/W							
Reset	0	0	0	0	0	0	0	0

8Ch.7~0 **TH0:** Timer0 data high byte

SFR 8Dh	Bit 7	Bit 6	Bit 5	Bit 4	Bit 3	Bit 2	Bit 1	Bit 0
<b>TH1</b>	TH1							
R/W	R/W							
Reset	0	0	0	0	0	0	0	0

8Dh.7~0 **TH1:** Timer1 data high byte

*Note:* also refer to Section 6 for more information about Timer0/1 Interrupt enable and priority.

*Note:* also refer to Section 7 for more information about T00 pin output setting.

## 8.2 Timer2

Timer2 is controlled through the TCON2 register with the low and high bytes of Timer/Counter 2 stored in TL2 and TH2 and the low and high bytes of the Timer2 reload/capture registers stored in RCAP2L and RCAP2H.

SFR C8h	Bit 7	Bit 6	Bit 5	Bit 4	Bit 3	Bit 2	Bit 1	Bit 0
<b>T2CON</b>	TF2	EXF2	RCLK	TCLK	EXEN2	TR2	CT2N	CPRL2N
R/W	R/W	R/W	R/W	R/W	R/W	R/W	R/W	R/W
Reset	0	0	0	0	0	0	0	0

C8h.7 **TF2:** Timer2 overflow flag  
 Set by H/W when Timer/Counter 2 overflows unless RCLK=1 or TCLK=1. This bit must be cleared by S/W.

C8h.6 **EXF2:** T2EX interrupt pin falling edge flag  
 Set when a capture or a reload is caused by a negative transition on T2EX pin if EXEN2=1. This bit must be cleared by S/W.

C8h.5 **RCLK:** UART receive clock control bit  
 0: Use Timer1 overflow as receive clock for serial port in mode 1 or 3  
 1: Use Timer2 overflow as receive clock for serial port in mode 1 or 3

- C8h.4 **TCLK:** UART transmit clock control bit  
 0: Use Timer1 overflow as transmit clock for serial port in mode 1 or 3  
 1: Use Timer2 overflow as transmit clock for serial port in mode 1 or 3
- C8h.3 **EXEN2:** T2EX pin enable  
 0: T2EX pin disable  
 1: T2EX pin enable, it cause a capture or reload when a negative transition on T2EX pin is detected if RCLK=TCLK=0
- C8h.2 **TR2:** Timer2 run control  
 0: Timer2 stops  
 1: Timer2 runs
- C8h.1 **CT2N:** Timer2 Counter/Timer select bit  
 0: Timer mode, Timer2 data increases at 2 System clock cycle rate  
 1: Counter mode, Timer2 data increases at T2 pin's negative edge
- C8h.0 **CPRL2N:** Timer2 Capture/Reload control bit  
 0: Reload mode, auto-reload on Timer2 overflows or negative transitions on T2EX pin if EXEN2=1  
 1: Capture mode, capture on negative transitions on T2EX pin if EXEN2=1  
 If RCLK=1 or TCLK=1, CPRL2N is ignored and timer is forced to auto-reload on Timer2 overflow

SFR CAh	Bit 7	Bit 6	Bit 5	Bit 4	Bit 3	Bit 2	Bit 1	Bit 0
<b>RCP2L</b>	RCP2L							
R/W	R/W							
Reset	0	0	0	0	0	0	0	0

CAh.7~0 **RCP2L:** Timer2 reload/capture data low byte

SFR CBh	Bit 7	Bit 6	Bit 5	Bit 4	Bit 3	Bit 2	Bit 1	Bit 0
<b>RCP2H</b>	RCP2H							
R/W	R/W							
Reset	0	0	0	0	0	0	0	0

CBh.7~0 **RCP2H:** Timer2 reload/capture data high byte

SFR CCh	Bit 7	Bit 6	Bit 5	Bit 4	Bit 3	Bit 2	Bit 1	Bit 0
<b>TL2</b>	TL2							
R/W	R/W							
Reset	0	0	0	0	0	0	0	0

CCh.7~0 **TL2:** Timer2 data low byte

SFR CDh	Bit 7	Bit 6	Bit 5	Bit 4	Bit 3	Bit 2	Bit 1	Bit 0
<b>TH2</b>	TH2							
R/W	R/W							
Reset	0	0	0	0	0	0	0	0

CDh.7~0 **TH2:** Timer2 data high byte

**Note:** also refer to Section 6 for more information about Timer2 Interrupt enable and priority.

**Note:** also refer to Section 7 for more information about T2O pin output setting.

### 8.3 Timer3

Timer3 of the Chip works as a time-base counter, which generates interrupts periodically. It generates an interrupt flag (TF3) with the clock divided by 32768, 16384, 8192, or 128 depending on the TM3PSC bits. The Timer3 clock source is Slow clock (SRC or SXT). This is ideal for real-time-clock (RTC) functionality when the clock source is SXT.

SFR 94h	Bit 7	Bit 6	Bit 5	Bit 4	Bit 3	Bit 2	Bit 1	Bit 0
<b>OPTION</b>	UART1W	MODE3V	WDTPSC		ADCKS		TM3PSC	
R/W	R/W	R/W	R/W		R/W		R/W	
Reset	0	0	0	0	0	0	0	0

94h.1~0 **TM3PSC:** Timer3 interrupt rate control select  
 00: Interrupt rate is 32768 Slow clock cycle  
 01: Interrupt rate is 16384 Slow clock cycle  
 10: Interrupt rate is 8192 Slow clock cycle  
 11: Interrupt rate is 128 Slow clock cycle

SFR 95h	Bit 7	Bit 6	Bit 5	Bit 4	Bit 3	Bit 2	Bit 1	Bit 0
<b>INTFLG</b>	LVD	–	TKIF	ADIF	–	IE2	P1IF	TF3
R/W	R	–	R/W	R/W	–	R/W	R/W	R/W
Reset	–	–	0	0	–	0	0	0

95h.0 **TF3:** Timer 3 interrupt flag  
 Set by H/W when Timer3 reaches TM3PSC setting cycles. It is cleared automatically when the program performs the interrupt service routine. S/W can write FEh to INTFLG to clear this bit. (*Note2*)

*Note2:* S/W can write 0 to clear a flag in the INTFLG, but writing 1 has no effect.

SFR F8h	Bit 7	Bit 6	Bit 5	Bit 4	Bit 3	Bit 2	Bit 1	Bit 0
<b>AUX1</b>	CLRWDT	CLRTM3	TKSOC	ADSOC	CLRPWM0	–	–	DPSEL
R/W	R/W	R/W	R/W	R/W	R/W	–	–	R/W
Reset	0	0	0	0	0	–	–	0

F8h.6 **CLRTM3:** Set to clear Timer3, H/W auto clear it at next clock cycle

*Note:* also refer to Section 6 for more information about Timer3 Interrupt enable and priority.

### 8.4 T00 and T20 Output Control

This device can generate various frequency waveform pin output (in CMOS or Open-Drain format) for Buzzer. The T00 and T20 waveform is divided by Timer0/Timer2 overflow signal. The T00 waveform is Timer0 overflow divided by 64, and T20 waveform is Timer2 overflow divided by 2. User can control their frequency by Timers auto reload speed. Set T0OE and T2OE SFRs can output these waveforms.

SFR A6h	Bit 7	Bit 6	Bit 5	Bit 4	Bit 3	Bit 2	Bit 1	Bit 0
<b>PINMOD</b>	PWM1OE	–	PWM0OE	–	TCOE	T2OE	–	–
R/W	R/W	–	R/W	–	R/W	R/W	–	–
Reset	0	–	0	–	0	0	–	–

A6h.2 **T2OE:** Timer2 signal output (T2O) control  
 0: Disable Timer2 overflow divided by 2 output to P1.0  
 1: Enable Timer2 overflow divided by 2 output to P1.0

SFR A5h	Bit 7	Bit 6	Bit 5	Bit 4	Bit 3	Bit 2	Bit 1	Bit 0
<b>P3MODH</b>	T0OE	–	P3MOD6		P3MOD5		P3MOD4	
R/W	R/W	–	R/W		R/W		R/W	
Reset	0	–	0	0	0	0	0	0

A5h.7 **T0OE:** Timer0 signal output (T0O) control  
 0: Disable Timer0 overflow divided by 64 output to P3.4  
 1: Enable Timer0 overflow divided by 64 output to P3.4



## 9. UART

The UART uses SCON and SBUF SFRs. SCON is the control register, SBUF is the data register. Data is written to SBUF for transmission and SBUF is read to obtain received data. The received data and transmitted data registers are completely independent. In addition to standard 8051's full duplex mode, this chip also provides one wire mode. If the UART1W bit is set, both transmit and receive data use P3.1 pin.

SFR 87h	Bit 7	Bit 6	Bit 5	Bit 4	Bit 3	Bit 2	Bit 1	Bit 0
<b>PCON</b>	SMOD	–	–	–	GF1	GF0	PD	IDL
R/W	R/W	–	–	–	R/W	R/W	R/W	R/W
Reset	0	–	–	–	0	0	0	0

87h.7 **SMOD:** UART double baud rate control bit

0: Disable UART double baud rate

1: Enable UART double baud rate

SFR 94h	Bit 7	Bit 6	Bit 5	Bit 4	Bit 3	Bit 2	Bit 1	Bit 0
<b>OPTION</b>	UART1W	MODE3V	WDTpsc		ADCKs		TM3Psc	
R/W	R/W	R/W	R/W		R/W		R/W	
Reset	0	0	0	0	0	0	0	0

94h.7 **UART1W:** One wire UART mode enable, both TXD/RXD use P3.1 pin

0: Disable one wire UART mode

1: Enable one wire UART mode

SFR 98h	Bit 7	Bit 6	Bit 5	Bit 4	Bit 3	Bit 2	Bit 1	Bit 0
<b>SCON</b>	SM0	SM1	SM2	REN	TB8	RB8	TI	RI
R/W	R/W	R/W	R/W	R/W	R/W	R/W	R/W	R/W
Reset	0	0	0	0	0	0	0	0

98h.7~6 **SM0,SM1:** Serial port mode select bit 0,1

00: Mode0: 8 bit shift register, Baud Rate= $F_{SYSCLK}/2$

01: Mode1: 8 bit UART, Baud Rate is variable

10: Mode2: 9 bit UART, Baud Rate =  $F_{SYSCLK}/32$  or  $/64$

11: Mode3: 9 bit UART, Baud Rate is variable

98h.5 **SM2:** Serial port mode select bit 2

SM2 enables multiprocessor communication over a single serial line and modifies the above as follows. In Modes 2 & 3, if SM2 is set then the received interrupt will not be generated if the received ninth data bit is 0. In Mode 1, the received interrupt will not be generated unless a valid stop bit is received. In Mode 0, SM2 should be 0.

98h.4 **REN:** UART reception enable

0: Disable reception

1: Enable reception

98h.3 **TB8:** Transmit Bit 8, the ninth bit to be transmitted in Mode 2 and 3

98h.2 **RB8:** Receive Bit 8, contains the ninth bit that was received in Mode 2 and 3 or the stop bit in Mode 1 if SM2=0

98h.1 **TI:** Transmit interrupt flag

Set by H/W at the end of the eighth bit in Mode 0, or at the beginning of the stop bit in other modes. Must be cleared by S/W.

98h.0 **RI:** Receive interrupt flag

Set by H/W at the end of the eighth bit in Mode 0, or at the sampling point of the stop bit in other modes. Must be cleared by S/W.

SFR 99h	Bit 7	Bit 6	Bit 5	Bit 4	Bit 3	Bit 2	Bit 1	Bit 0
<b>SBUF</b>	SBUF							
R/W	R/W							
Reset	–	–	–	–	–	–	–	–

99h.7~0 **SBUF**: UART transmit and receive data. Transmit data is written to this location and receive data is read from this location, but the paths are independent.

$F_{\text{SYSCLK}}$  denotes System clock frequency.

- Mode 0:  
Baud Rate= $F_{\text{SYSCLK}}/2$
- Mode 1, 3: if using Timer1 auto reload mode  
Baud Rate= $(\text{SMOD} + 1) \times F_{\text{SYSCLK}} / (32 \times 2 \times (256 - \text{TH1}))$
- Mode 1, 3: if using Timer2  
Baud Rate=Timer2 overflow rate/16= $F_{\text{SYSCLK}} / (32 \times (65536 - \text{RCP2H}, \text{RCP2L}))$
- Mode 2:  
Baud Rate= $(\text{SMOD} + 1) \times F_{\text{SYSCLK}}/64$

**Note:** also refer to Section 6 for more information about UART Interrupt enable and priority.

**Note:** also refer to Section 8 for more information about how Timer2 controls UART clock.

## 10. PWMs

The Chip has two independent PWM modules, PWM0 and PWM1. The PWM can generate a fixed frequency waveform with 1024 duty resolution on the basis of the PWM clock. The PWM clock can select FRC double frequency (FRCx2) or  $F_{SYSCLK}$  divided by 1, 2, or 4 as its clock source. A spread LSB technique allows PWM to run its frequency at the “PWM clock divided by 256” instead of at the “PWM clock divided by 1024”, which means the PWM is four times faster than normal. The advantage of a higher PWM frequency is that the post RC filter can transform the PWM signal to a more stable DC voltage level.

The PWM output signal resets to a low level whenever the 8-bit base counter matches the 8-bit MSB of the PWM duty register. When the base counter rolls over, the 2-bit LSB of the PWM duty register decides whether to set the PWM output signal high immediately or set it high after one clock cycle delay. The PWM period can be set by writing the period value to the 8-bit PWM period register.

The pin mode SFR controls the PWM output waveform format. Mode1 makes the PWM open drain output and Mode2 makes the PWM CMOS push-pull output. (*see section 7*)

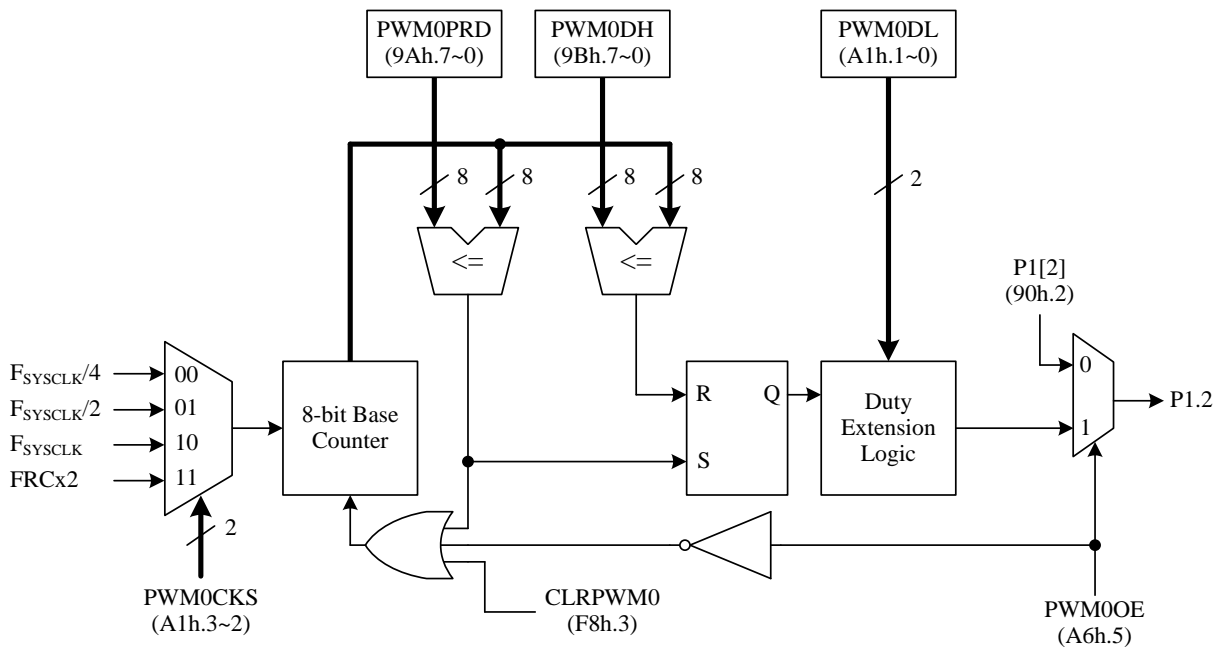

**PWM Structure**

SFR 9Ah	Bit 7	Bit 6	Bit 5	Bit 4	Bit 3	Bit 2	Bit 1	Bit 0
<b>PWM0PRD</b>	PWM0PRD							
R/W	R/W							
Reset	1	1	1	1	1	1	1	1

9Ah.7~0 **PWM0PRD**: PWM0 8-bit period register

SFR 9Bh	Bit 7	Bit 6	Bit 5	Bit 4	Bit 3	Bit 2	Bit 1	Bit 0
<b>PWM0DH</b>	PWM0DH							
R/W	R/W							
Reset	1	0	0	0	0	0	0	0

9Bh.7~0 **PWM0DH**: bits 9~2 of the PWM0 10-bit duty register

SFR 9Ch	Bit 7	Bit 6	Bit 5	Bit 4	Bit 3	Bit 2	Bit 1	Bit 0
<b>PWM1PRD</b>	PWM1PRD							
R/W	R/W							
Reset	1	1	1	1	1	1	1	1

9Ch.7~0 **PWM1PRD**: PWM1 8-bit period register

SFR 9Dh	Bit 7	Bit 6	Bit 5	Bit 4	Bit 3	Bit 2	Bit 1	Bit 0
<b>PWM1DH</b>	PWM1DH							
R/W	R/W							
Reset	1	0	0	0	0	0	0	0

9Dh.7~0 **PWM1DH**: bits 9~2 of the PWM1 10-bit duty register

SFR A1h	Bit 7	Bit 6	Bit 5	Bit 4	Bit 3	Bit 2	Bit 1	Bit 0
<b>PWMCON</b>	PWM1CKS		PWM1DL		PWM0CKS		PWM0DL	
R/W	R/W		R/W		R/W		R/W	
Reset	1	0	0	0	1	0	0	0

A1h.7~6 **PWM1CKS**: PWM1 clock source

- 00:  $F_{SYSCLK}/4$
- 01:  $F_{SYSCLK}/2$
- 10:  $F_{SYSCLK}$
- 11: FRCx2

A1h.5~4 **PWM1DL**: bits 1~0 of the PWM1 10-bit duty register

A1h.3~2 **PWM0CKS**: PWM0 clock source

- 00:  $F_{SYSCLK}/4$
- 01:  $F_{SYSCLK}/2$
- 10:  $F_{SYSCLK}$
- 11: FRCx2

A1h.1~0 **PWM0DL**: bits 1~0 of the PWM0 10-bit duty register

SFR A6h	Bit 7	Bit 6	Bit 5	Bit 4	Bit 3	Bit 2	Bit 1	Bit 0
<b>PINMOD</b>	PWM1OE	–	PWM0OE	–	TCOE	T2OE	–	–
R/W	R/W	–	R/W	–	R/W	R/W	–	–
Reset	0	–	0	–	0	0	–	–

A6h.7 **PWM1OE**: PWM1 signal output enable

- 0: Disable PWM1 signal output to P1.3
- 1: Enable PWM1 signal output to P1.3

A6h.5 **PWM0OE**: PWM0 signal output enable

- 0: Disable PWM0 signal output to P1.2
- 1: Enable PWM0 signal output to P1.2

SFR F8h	Bit 7	Bit 6	Bit 5	Bit 4	Bit 3	Bit 2	Bit 1	Bit 0
<b>AUX1</b>	CLRWDT	CLRTM3	TKSOC	ADSOC	CLRPWM0	–	–	DPSEL
R/W	R/W	R/W	R/W	R/W	R/W	–	–	R/W
Reset	0	0	0	0	0	–	–	0

F8h.3 **CLRPWM0**: PWM0 clear enable

- 0: PWM0 is running
- 1: PWM0 is cleared and held

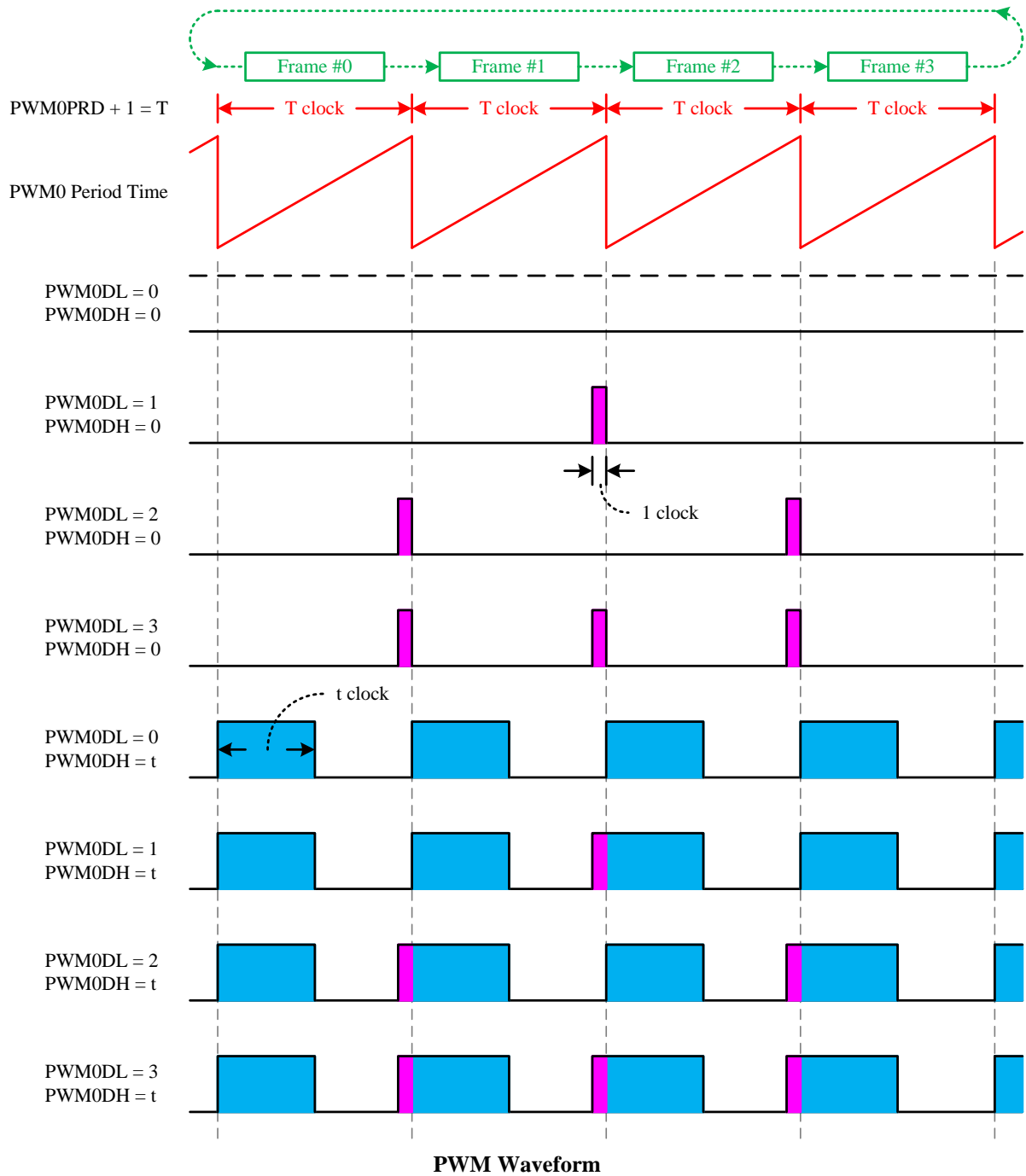

### 11. ADC

The Chip offers a 12-bit ADC consisting of a 12-channel analog input multiplexer, control register, clock generator, 12-bit successive approximation register, and output data register. To use the ADC, set the ADCKS bit first to choose a proper ADC clock frequency, which must be less than 1 MHz. Then, launch the ADC conversion by setting the ADSOC bit, and H/W will automatic clear it at the end of the conversion. After the end of the conversion, H/W will set the ADIF bit and generate an interrupt if an ADC interrupt is enabled. The ADIF bit can be cleared by writing 0 to this bit or 1 to the ADSOC bit. Because certain channels are shared with the Touch Key, the ADC channel must be configured differently from the Touch Key channel to avoid affecting the channel input sensitivity. The analog input level must remain within the range from  $V_{SS}$  to  $V_{CC}$ .

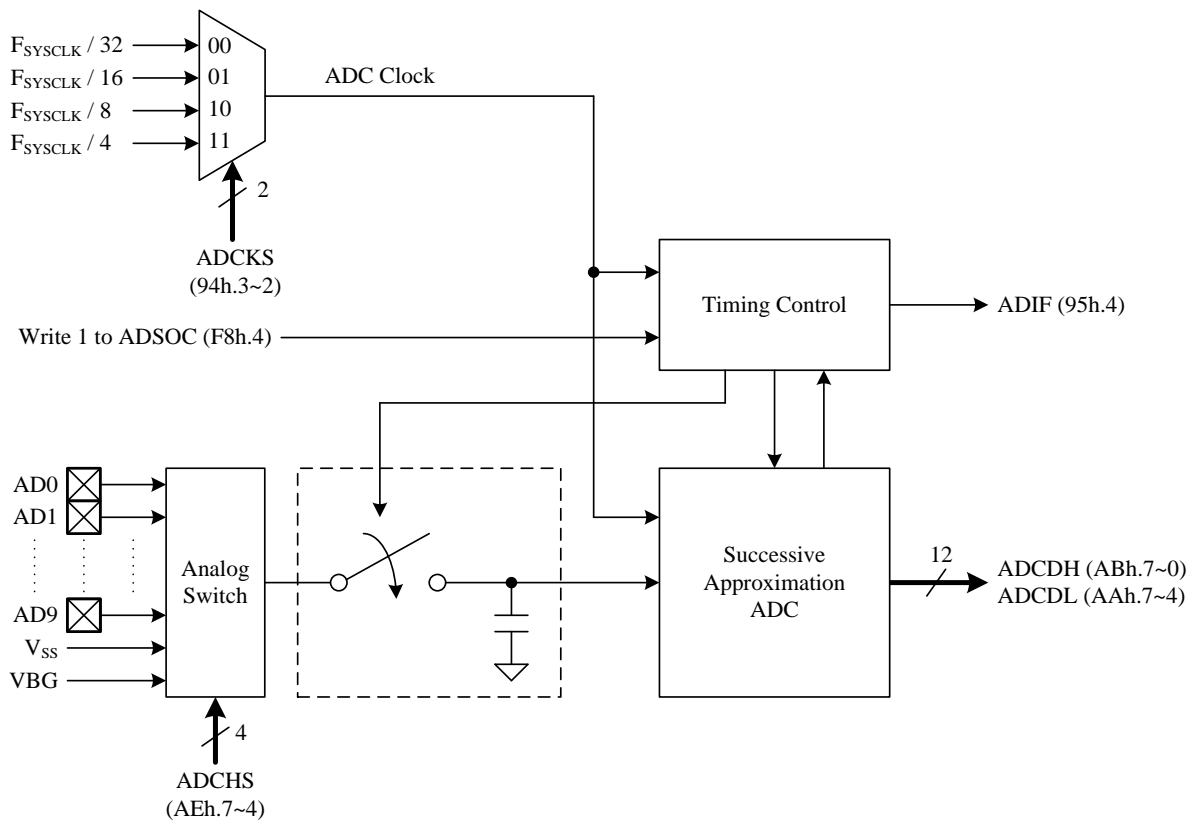

### 11.1 ADC Channels

The 12-bit ADC has a total of 12 channels, designated AD0~AD9, V<sub>SS</sub>, and VBG. The ADC channels are connected to the analog input pins via the analog switch multiplexer. The analog switch multiplexer is controlled by the ADCHS register. The Chip offers up to 10 analog input pins, designated AD0~AD9. In addition, there are two analog input pins for voltage reference connections. When ADCHS is set to 1010b, the analog input will connect to V<sub>SS</sub>, and when ADCHS is set to 1011b, the analog input will connect to VBG. VBG is an internal voltage reference at 1.2V.

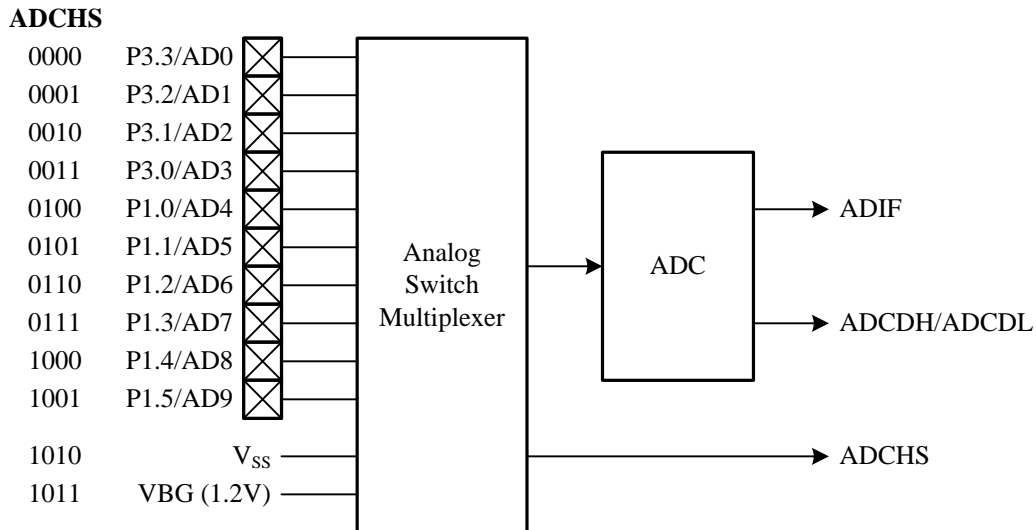

### 11.2 ADC Conversion Time

The conversion time is the time required for the ADC to convert the voltage. The ADC requires two ADC clock cycles to convert each bit and several clock cycles to sample and hold the input voltage. A total of 50 ADC clock cycles are required to perform the complete conversion. When the conversion time is complete, the ADIF interrupt flag is set by H/W, and the result is loaded into the ADCDH and ADCDL registers of the 12-bit A/D result.

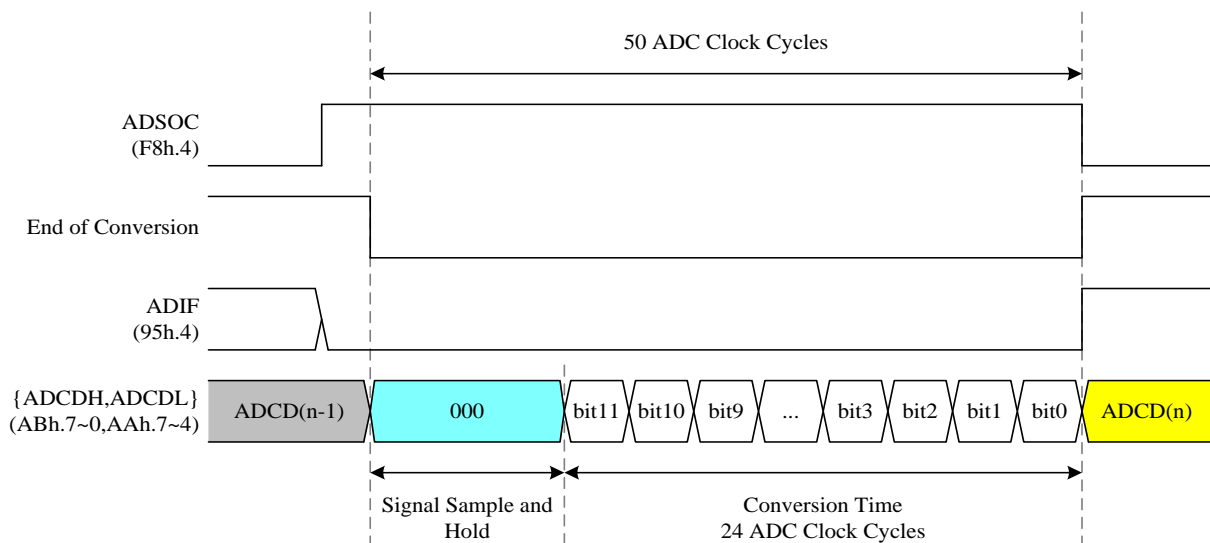

SFR 94h	Bit 7	Bit 6	Bit 5	Bit 4	Bit 3	Bit 2	Bit 1	Bit 0
<b>OPTION</b>	UART1W	MODE3V	WDTOSC		ADCKS		TM3PSC	
R/W	R/W	R/W	R/W		R/W		R/W	
Reset	0	0	0	0	0	0	0	0

94h.3~2 **ADCKS**: ADC clock rate select

00:  $F_{SYSCLK}/32$

01:  $F_{SYSCLK}/16$

10:  $F_{SYSCLK}/8$

11:  $F_{SYSCLK}/4$

SFR 95h	Bit 7	Bit 6	Bit 5	Bit 4	Bit 3	Bit 2	Bit 1	Bit 0
<b>INTFLG</b>	LVD	–	TKIF	ADIF	–	IE2	PIIF	TF3
R/W	R	–	R/W	R/W	–	R/W	R/W	R/W
Reset	–	–	0	0	–	0	0	0

95h.4 **ADIF**: ADC interrupt flag

Set by H/W at the end of conversion. S/W writes EFh to INTFLG or sets the ADSOC bit to clear this flag.

SFR AAh	Bit 7	Bit 6	Bit 5	Bit 4	Bit 3	Bit 2	Bit 1	Bit 0
<b>ADTKDT</b>	ADCDL				TKEOC	TKOVF	TKDH	
R/W	R				R	R	R	
Reset	–	–	–	–	–	–	–	–

AAh.7~4 **ADCDL**: ADC data bit 3~0

SFR ABh	Bit 7	Bit 6	Bit 5	Bit 4	Bit 3	Bit 2	Bit 1	Bit 0
<b>ADCDH</b>	ADCDH							
R/W	R							
Reset	–	–	–	–	–	–	–	–

ABh.7~0 **ADCDH**: ADC data bit 11~4

SFR AEh	Bit 7	Bit 6	Bit 5	Bit 4	Bit 3	Bit 2	Bit 1	Bit 0
<b>CHSEL</b>	ADCHS				TKCHS			
R/W	R/W				R/W			
Reset	1	1	1	1	1	1	1	1

AEh.7~4 **ADCHS**: ADC channel select

0000: ADC0 (P3.3)

0001: ADC1 (P3.2)

0010: ADC2 (P3.1)

0011: ADC3 (P3.0)

0100: ADC4 (P1.0)

0101: ADC5 (P1.1)

0110: ADC6 (P1.2)

0111: ADC7 (P1.3)

1000: ADC8 (P1.4)

1001: ADC9 (P1.5)

1010:  $V_{SS}$

1011: VBG (internal Bandgap reference voltage)

11xx: Undefined

**Note**: FW must turn off Bandgap to obtain Tiny Current (ADCHS ≠ 0b1011)



SFR F8h	Bit 7	Bit 6	Bit 5	Bit 4	Bit 3	Bit 2	Bit 1	Bit 0
<b>AUX1</b>	CLRWDT	CLRTM3	TKSOC	ADSOC	CLRPWM0	–	–	DPSEL
R/W	R/W	R/W	R/W	R/W	R/W	–	–	R/W
Reset	0	0	0	0	0	–	–	0

F8h.4 **ADSOC: Start ADC conversion**

Set the ADSOC bit to start ADC conversion, and the ADSOC bit will be cleared by H/W at the end of conversion. S/W can also write 0 to clear this flag.

*Note:* also refer to Section 6 for more information about ADC Interrupt enable and priority.

*Note:* also refer to Section 7 for more information about ADC pin input setting.

## 12. Touch Key (F5268 Only)

The Touch Key offers an easy, simple and reliable method to implement finger touch detection. During the key scan operation, it only requires an external capacitor component on CLD pin. The device support 14 channels touch key detection with S/W manual mode and H/W Auto Mode (ATK). Only one mode can be active at a time.

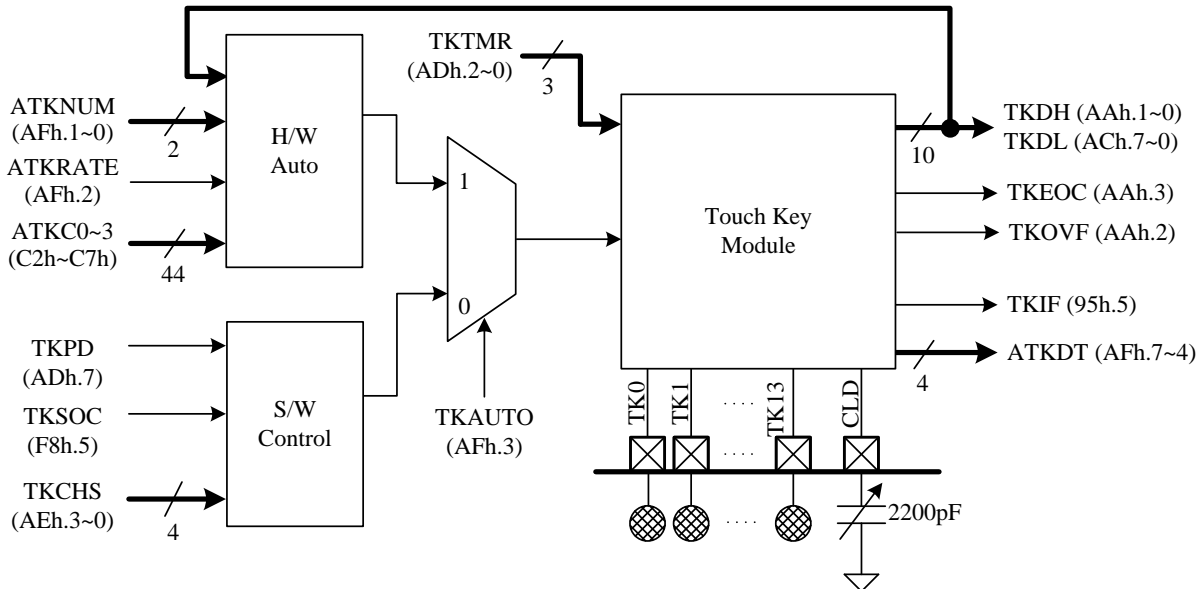

**Touch Key Structure**

To use the Touch Key, user must setup the pin mode correctly as below table. Setting Mode0 for an Idling Touch Key pin can pull up the pin and reduce the Key's mutual interference. While a TK pin is under scanning, user must set the pin to Mode3 to disable the pull up resistor.

P1MODx/P3MODx setting for Touch Key	TK0~TK3	TK4~TK8	TK9~TK13	CLD
Pin is not Touch Key	Mode0/1/2/3	Mode0/1/2/3	Mode0/1/2	Mode0/1/2/3
Pin is Touch Key, Idling	Mode0	Mode0	Mode0	Mode3
Pin is Touch Key, S/W Scanning	Mode3	Mode3	Mode3	Mode3
Pin is Touch Key, H/W Auto Scan (ATK)	Mode0	—	—	Mode3

### S/W Manual Mode Touch Key Detection

All Touch Key (TK0~TK13) can be used for S/W manual mode. To start the S/W mode, user assigns TKAUTO=0 and TKPD=0, then set the TKSOC bit to start touch key conversion, the TKSOC bit can be automatically cleared while end of conversion. However, if the SYSCLK is too slow, H/W might fail to clear TKSOC due to clock sampling rate. TKEOC=0 means conversion is in process. TKEOC=1 means the conversion is finish, and the touch key counting result is stored into the 10 bits TK Data Counter TKDH and TKDL. After TKEOC=1, user must wait at least 50 μs for next conversion. If TKOVF=1, means the conversion transaction exceeds period time. Reduce/Increase TKTMR can reduce/increase TK Data Count to adapt the system board circumstances.

The Touch Key unit has an internal built-in reference capacitor to simulate the KEY behavior. Set TKCHS=15 and start the S/W scan mode can get the TK Data Count of this capacitor. Since the internal capacitor would not be affected by water or mobile phone, it is useful for comparing the environment background noise.

**Note:** CLD discharge time is in proportion to CLD capacitance, refer to [AP-TM52\\_57XX\\_Touch\\_02S](#)

**H/W Auto Touch Key Detection (ATK)**

Only TK0~TK3 are eligible for H/W auto mode. This function can work in Fast/Slow/Idle mode and save the S/W effort as well as minimize the chip current consumption. To use this function, user need to set TKAUTO=1 and TKPD=1 to enable H/W fully control the TK unit. H/W then automatically detects the TK0~TK3's TK Data Count at every 2048 or 4096 Slow clock cycles. If a Key's TK Data Count is less than the pre-set compare threshold (ATKCO~3), H/W generates interrupt and wake up CPU. User can switch the TK module back to S/W Manual Mode after the TK interrupt and identify/confirm the Key touch event.

SFR 95h	Bit 7	Bit 6	Bit 5	Bit 4	Bit 3	Bit 2	Bit 1	Bit 0
<b>INTFLG</b>	LVD	–	TKIF	ADIF	–	IE2	P1IF	TF3
R/W	R	–	R/W	R/W	–	R/W	R/W	R/W
Reset	–	–	0	0	–	0	0	0

**95h.5 TKIF: Touch Key interrupt flag**

In the S/W Manual mode: Set by H/W at the end of conversion. S/W writes DFh to INTFLG or sets the TKSOC bit to clear this flag.

In the ATK mode: Set by H/W when a TK channel's touch event is detected. It is cleared automatically when the program performs the interrupt service routine. S/W can write DFh to INTFLG to clear this bit.

**Note:** In ATK mode, this flag may be cleared improperly by ADC module. User should not start the ADC conversion in ATK mode.

SFR AAh	Bit 7	Bit 6	Bit 5	Bit 4	Bit 3	Bit 2	Bit 1	Bit 0
<b>ADTKDT</b>	ADCDL				TKEOC	TKOVF	TKDH	
R/W	R				R	R	R	
Reset	–	–	–	–	–	–	–	–

**AAh.3 TKEOC: Touch Key end of conversion flag, TKEOC may have 3uS delay after TKSOC=1, so F/W must wait enough time before polling this Flag.**

0: Indicates conversion is in progress

1: Indicates conversion is finished

**AAh.2 TKOVF: Touch Key counter overflow**

0: Indicates that the counter has not overflow

1: Indicates that the counter has overflow

**AAh.1~0 TKDH: Touch Key counter data bit 9~8**

SFR ACh	Bit 7	Bit 6	Bit 5	Bit 4	Bit 3	Bit 2	Bit 1	Bit 0
<b>TKDL</b>	TKDL							
R/W	R							
Reset	–	–	–	–	–	–	–	–

**ACh.7~0 TKDL: Touch Key counter data bit 7~0**

SFR ADh	Bit 7	Bit 6	Bit 5	Bit 4	Bit 3	Bit 2	Bit 1	Bit 0
<b>TKCON</b>	TKPD	–	–	–	–	TKTMR		
R/W	R/W	–	–	–	–	R/W		
Reset	1	–	–	–	–	1	0	0

**ADh.7 TKPD: Touch Key power down**

0: Touch Key running

1: Touch Key power down

**ADh.2~0 TKTMR: Touch Key conversion time select**

TKTMR adjusts the value of Touch Key reference voltage. A larger value of TKTMR requires a longer charging time, which can affect the sensitivity of touch sensing.

000: Conversion time shortest

...

111: Conversion time longest

SFR AEh	Bit 7	Bit 6	Bit 5	Bit 4	Bit 3	Bit 2	Bit 1	Bit 0
<b>CHSEL</b>	ADCHS				TKCHS			
R/W	R/W				R/W			
Reset	1	1	1	1	1	1	1	1

AEh.3~0 **TKCHS:** Touch Key channel select

- 0000: TK0 (P1.0)
- 0001: TK1 (P1.1)
- 0010: TK2 (P1.2)
- 0011: TK3 (P1.3)
- 0100: TK4 (P3.3)
- 0101: TK5 (P3.2)
- 0110: TK6 (P3.1)
- 0111: TK7 (P3.0)
- 1000: TK8 (P1.4)
- 1001: TK9 (P1.6)
- 1010: TK10 (P1.7)
- 1011: TK11 (P3.6)
- 1100: TK12 (P3.5)
- 1101: TK13 (P3.4)
- 1110: Undefined
- 1111: Internal reference capacitor

SFR AFh	Bit 7	Bit 6	Bit 5	Bit 4	Bit 3	Bit 2	Bit 1	Bit 0
<b>TKCON2</b>	ATKDT				TKAUTO	ATKRATE	ATKNUM	
R/W	R				R/W	R/W	R/W	
Reset	–	–	–	–	0	0	1	1

AFh.7~4 **ATKDT:** Touch Key Auto Scan Result (for H/W ATK Mode)

- xxx1: TK0 has a Touch event
- xx1x: TK1 has a Touch event
- x1xx: TK2 has a Touch event
- 1xxx: TK3 has a Touch event

AFh.3 **TKAUTO:** Touch Key Auto Scan Mode Enable

- 0: S/W Mode
- 1: H/W ATK Mode

AFh.2 **ATKRATE:** Touch Key Scan Rate (for H/W ATK Mode)

- 0: ATK scan rate at every 4096 Slow clock cycles
- 1: ATK scan rate at every 2048 Slow clock cycles

AFh.1~0 **ATKNUM:** Touch Key Auto Scan Channel Number (for H/W ATK Mode)

- 00: ATK only detect TK0
- 01: ATK detect TK0 and TK1
- 10: ATK detect TK0~TK2
- 11: ATK detect TK0~TK3

SFR C2h	Bit 7	Bit 6	Bit 5	Bit 4	Bit 3	Bit 2	Bit 1	Bit 0
<b>ATKC10H</b>	–	ATKC1H			–	ATKC0H		
R/W	–	R/W			–	R/W		
Reset	–	0	0	0	–	0	0	0

C2h.6~4 **ATKC1H:** Data Threshold bit 10~8 Compared with TK1 scan (for H/W ATK Mode)

C2h.2~0 **ATKC0H:** Data Threshold bit 10~8 Compared with TK0 scan (for H/W ATK Mode)

SFR C3h	Bit 7	Bit 6	Bit 5	Bit 4	Bit 3	Bit 2	Bit 1	Bit 0
<b>ATKC32H</b>	–	ATKC3H			–	ATKC2H		
R/W	–	R/W			–	R/W		
Reset	–	0	0	0	–	0	0	0

C3h.6~4 **ATKC3H:** Data Threshold bit 10~8 Compared with TK3 scan (for H/W ATK Mode)

C3h.2~0 **ATKC2H:** Data Threshold bit 10~8 Compared with TK2 scan (for H/W ATK Mode)

SFR C4h	Bit 7	Bit 6	Bit 5	Bit 4	Bit 3	Bit 2	Bit 1	Bit 0
<b>ATKC0L</b>	ATKC0L							
R/W	R/W							
Reset	0	1	0	0	0	0	0	0

C4h.7~0 **ATKC0L**: Data Threshold bit 7~0 Compared with TK0 scan (for H/W ATK Mode)

SFR C5h	Bit 7	Bit 6	Bit 5	Bit 4	Bit 3	Bit 2	Bit 1	Bit 0
<b>ATKC1L</b>	ATKC1L							
R/W	R/W							
Reset	0	1	0	0	0	0	0	0

C5h.7~0 **ATKC1L**: Data Threshold bit 7~0 Compared with TK1 scan (for H/W ATK Mode)

SFR C6h	Bit 7	Bit 6	Bit 5	Bit 4	Bit 3	Bit 2	Bit 1	Bit 0
<b>ATKC2L</b>	ATKC2L							
R/W	R/W							
Reset	0	1	0	0	0	0	0	0

C6h.7~0 **ATKC2L**: Data Threshold bit 7~0 Compared with TK2 scan (for H/W ATK Mode)

SFR C7h	Bit 7	Bit 6	Bit 5	Bit 4	Bit 3	Bit 2	Bit 1	Bit 0
<b>ATKC3L</b>	ATKC3L							
R/W	R/W							
Reset	0	1	0	0	0	0	0	0

C7h.7~0 **ATKC3L**: Data Threshold bit 7~0 Compared with TK3 scan (for H/W ATK Mode)

SFR F8h	Bit 7	Bit 6	Bit 5	Bit 4	Bit 3	Bit 2	Bit 1	Bit 0
<b>AUX1</b>	CLRWDT	CLRTM3	TKSOC	ADSOC	CLRPWM0	–	–	DPSEL
R/W	R/W	R/W	R/W	R/W	R/W	–	–	R/W
Reset	0	0	0	0	0	–	–	0

F8h.5 **TKSOC**: Start Touch Key conversion

Set the TKSOC bit to start Touch Key conversion, and the TKSOC bit will be cleared by H/W at the end of conversion. S/W can also write 0 to clear this flag.

**Note:** also refer to Section 6 for more information about Touch Key Interrupt enable and priority.

**Note:** also refer to Section 7 for more information about Touch Key pin input setting.

### 13. Serial Peripheral Interface (SPI)

The Serial Peripheral Interface (SPI) module is capable of full-duplex, synchronous, serial communication between the MCU and peripheral devices. The peripheral devices can be other MCUs, A/D converter, sensors, or flash memory, etc. The SPI runs at a clock rate up to the system clock divided by two. Firmware can read the status flags, or the operation can be interrupt driven. Following figure shows the SPI system block diagram.

The features of the SPI module include:

- Master or Slave mode operation
- 3-wire or 4-wire mode operation
- Full-duplex operation
- Programmable transmit bit rate
- Single buffer receive
- Serial clock phase and polarity options
- MSB-first or LSB-first shifting selectable

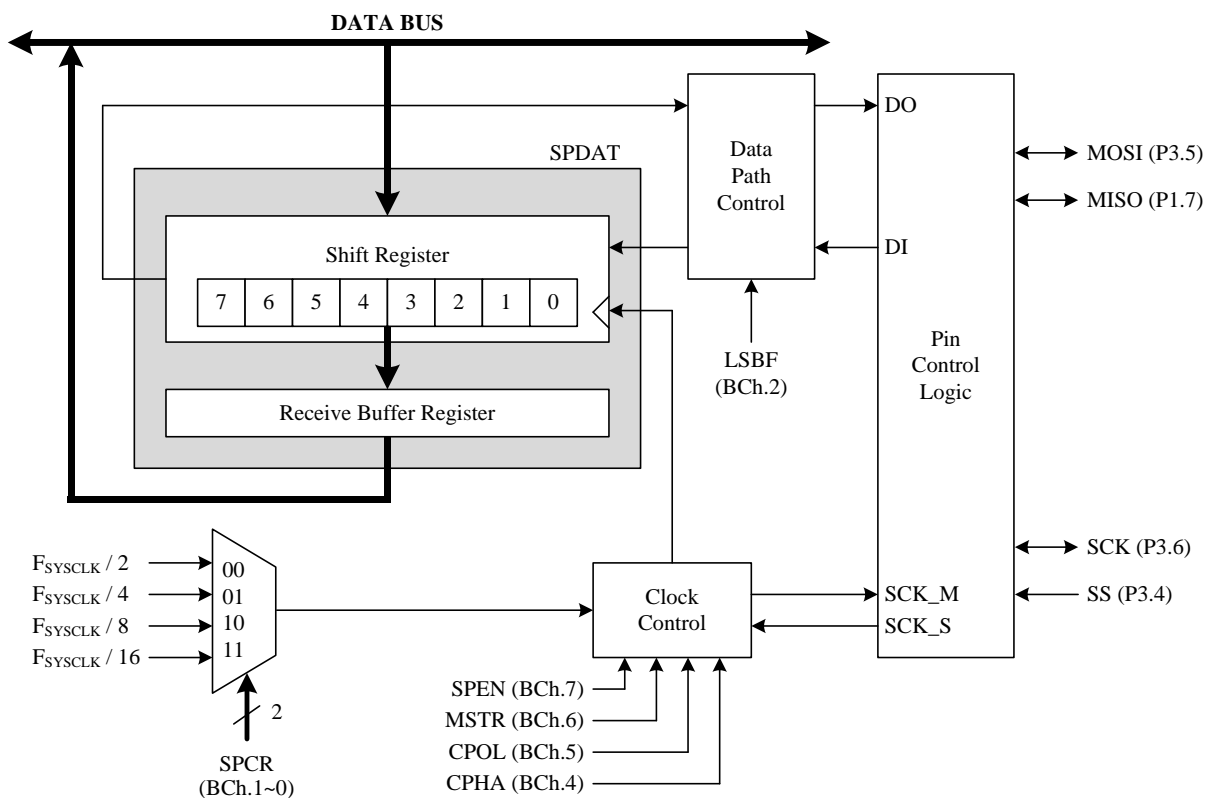

SPI Function Pin	P1/P3 Mode	P1.n/P3.n SFR data
Master Mode, MISO	Mode1	1
Master Mode, SCK, MOSI	Mode2	X
Slave Mode, MISO	Mode2	X
Slave Mode, SCK, MOSI	Mode1	1
SS	Mode1	1

Pin Mode Setting for SPI

The four signals used by SPI are described below. The MOSI (P3.5) signal is an output from a Master Device and an input to Slave Devices. The MISO (P1.7) signal is an output from a Slave Device and an input to a Master Device. Data is transferred most-significant bit (MSB) or least-significant bit (LSB) first by setting the LSBF bit. The SCK (P3.6) signal is an output from a Master Device and an input to Slave Devices. It is used to synchronize the data on the MOSI and MISO lines of Master and Slave. SPI generates the signal with eight programmable clock rates in Master mode. The SS (P3.4) signal is a low active slave select pin. In 4-wire Slave mode, the signal is ignored when the Slave is not selected (SS=1). The SS is ignored when the SSDIS in SPCON is set in both Master and Slave modes. In Slave mode and the SSDIS is clear, the SPI active when SS stay low. For multiple-slave mode, only one slave device is selected at a time to avoid bus collision on the MISO line. In Master mode and the SSDIS is cleared, the MODF in SPSTA is set when this signal is low. For multiple-master mode, enable SS line to avoid multiple driving on MOSI and SCK lines from multiple masters.

### Master Mode

The SPI operates in Master mode by setting the MSTR bit in the SPCON. To start transmit, writing a data to the SPDAT. If the SPBSY bit is cleared, the data will be transferred to the shift register and starts shift out on the MOSI line. The data of the slave shift in from the MISO line at the same time. When the SPIF bit in the SPSTA becomes set at the end of the transfer, the receive data is written to receiver buffer and the RCVBF bit in the SPSTA is set. To prevent an overrun condition, software must read the SPDAT before next byte enters the shift register. The SPBSY bit will be set when writing a data to SPDAT to start transmit, and be cleared at the end of the eighth SCK period in Master mode.

### Slave Mode

The SPI operates in Slave mode by clearing the MSTR bit in the SPCON. If the SSDIS is cleared, the transmission will start when the SS become low and remain low until the end of a data transfer. If the SSDIS is set, the transmission will start when the SPEN bit in the SPCON is set, and don't care the SS. The data from a master will shift into the shift register through the MOSI line, and shift out from the shift register on the MISO line. When a byte enters the shift register, the data will be transferred to receiver buffer if the RCVBF is cleared. If the RCVBF is set, the newer receive data will not be transferred to receiver buffer and the RCVOVF bit is set. After a byte enters the shift register, the SPIF and RCVBF bits are set. To prevent an overrun condition, software must read the SPDAT or write 0 to RCVBF before next byte enters the shift register. The maximum SCK frequency allowed in Slave mode is  $F_{\text{SYSCLK}}/4$ . In Slave mode, the SPBSY bit refers to the SS pin when the SSDIS bit is cleared, and refer to the SPEN bit when SSDIS bit is set.

### Serial Clock

The SPI has four clock types by setting the CPOL and CPHA bits in the SPCON register. The CPOL bit defines the level of the SCK in SPI idle state. The level of the SCK in idle state is low when the CPOL bit is cleared, and is high when the CPOL bit is set. The CPHA bit defines the edges used to sample and shift data. The SPI sample data on the first edge of SCK period and shift data on the second edge of SCK period when the CPHA bit is cleared. The SPI sample data on the second edge of SCK period and shift data on first edge of SCK period when the CPHA bit is set. The figures below show the detail timing in Master and Slave modes. Both Master and Slave devices must be configured to use the same clock type before the SPEN bit is set. The SPCR controls the Master mode serial clock frequency. This register is ignored when operating in Slave mode. The SPI clock can select System clock divided by 2, 4, 8, or 16 in Master mode.

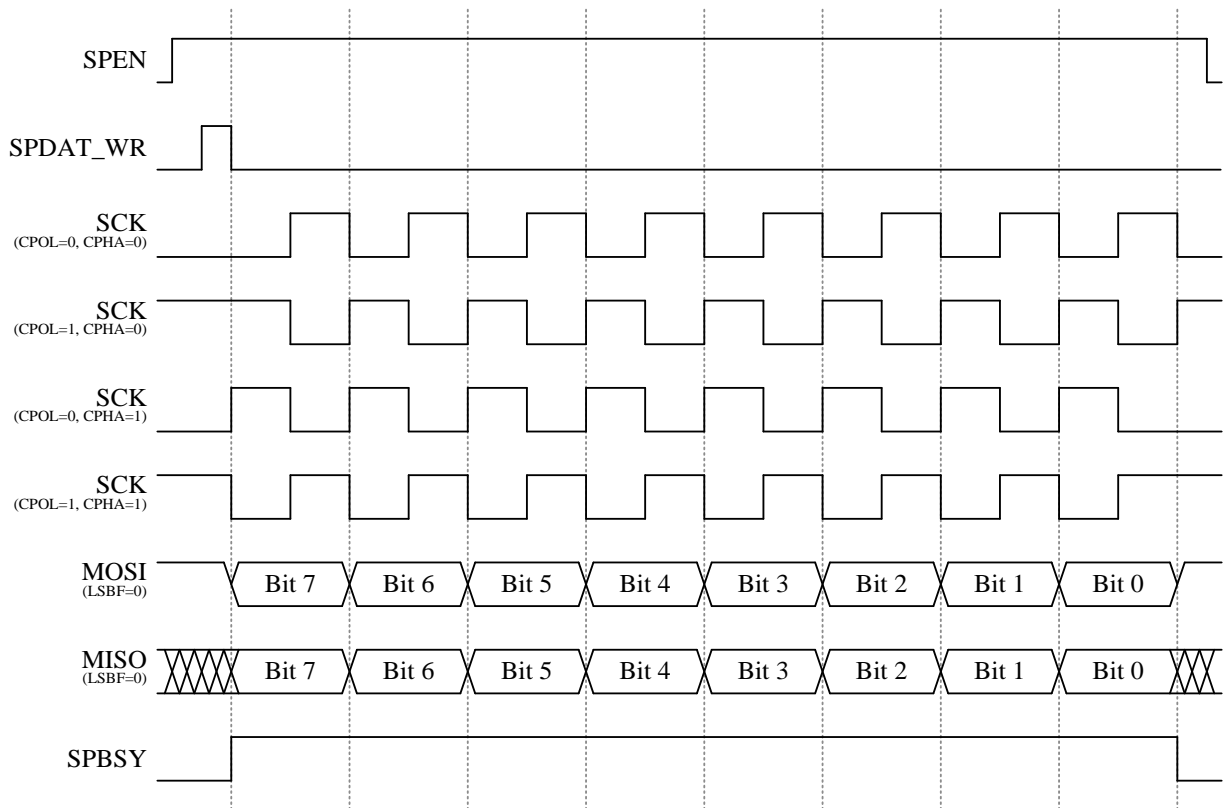

Master Mode Timing

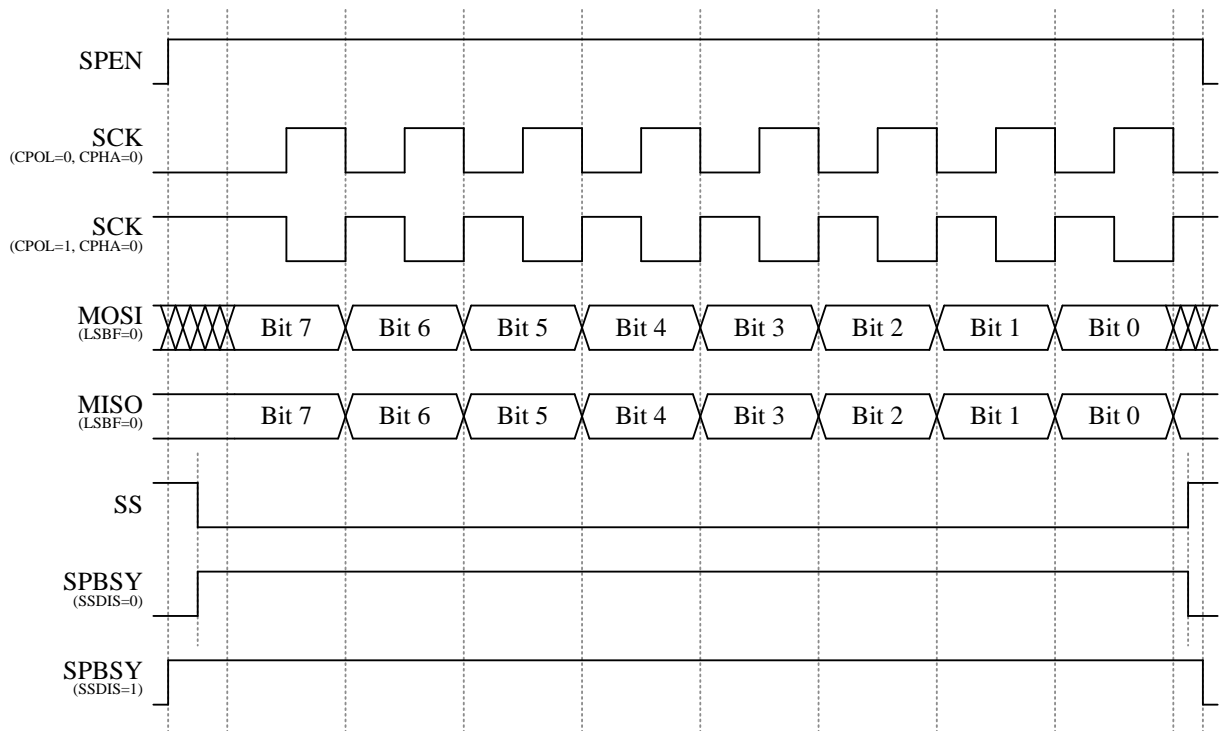

Slave Mode Timing (CPHA=0)

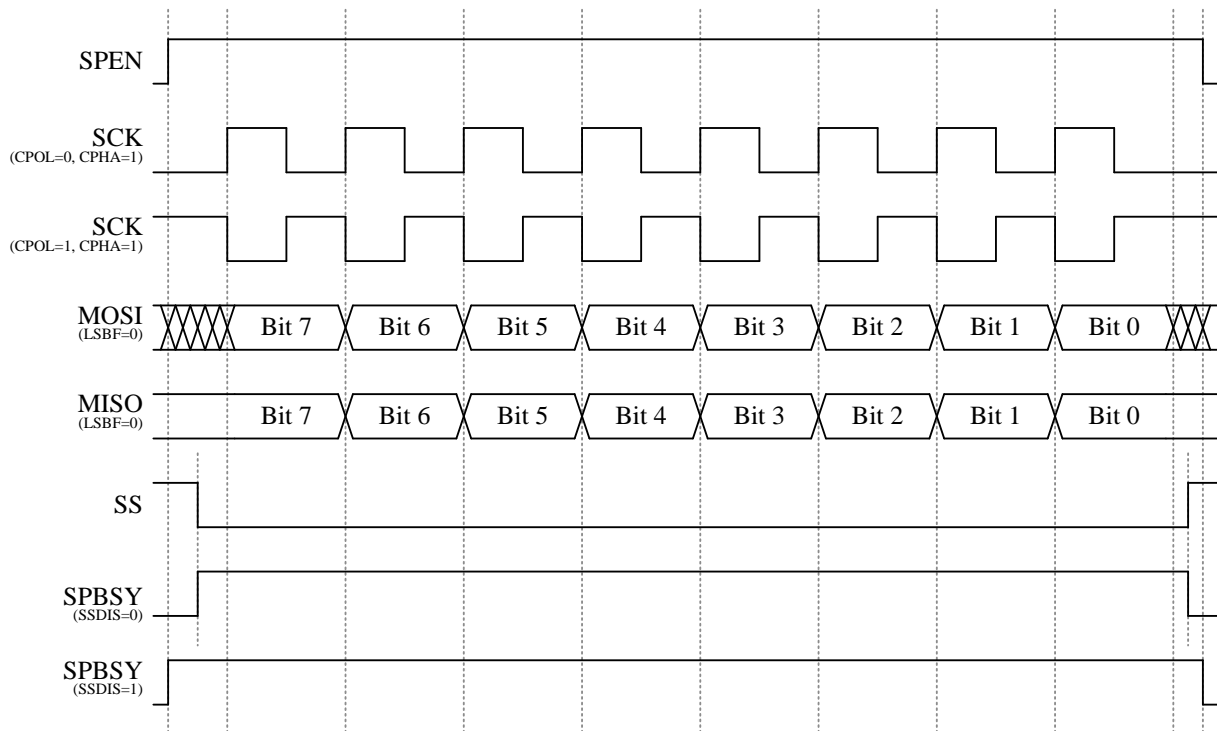

**Slave Mode Timing (CPHA=1)**

In both Master and Slave modes, the SPIF bit is set by H/W at the end of a data transfer and generates an interrupt if SPI interrupt is enabled. The SPIF bit is cleared automatically when the program performs the interrupt service routines. S/W can also write 0 to clear this flag. If write data to SPDAT when the SPBSY is set, the WCOL bit will be set by H/W and generates an interrupt if SPI interrupt is enabled. When this occurs, the data write to SPDAT will be ignored, and shift register will not be written. Write 0 to this bit or when SPBSY is cleared and rewrite data to SPDAT will clear this flag. The MODF bit is set when SSDIS is cleared and SS pin is pulled low in Master mode. If SPI interrupt is enabled, an interrupt will be generated. When this bit is set, the SPEN and MSTR in SPCON will be cleared by H/W. Write 0 to this bit will clear this flag.

SFR BCh	Bit 7	Bit 6	Bit 5	Bit 4	Bit 3	Bit 2	Bit 1	Bit 0
<b>SPCON</b>	SPEN	MSTR	CPOL	CPHA	SSDIS	LSBF	SPCR	
R/W	R/W	R/W	R/W	R/W	R/W	R/W	R/W	
Reset	0	0	0	0	0	0	0	0

- BCh.7 **SPEN:** SPI enable  
0: SPI disable  
1: SPI enable
- BCh.6 **MSTR:** Master mode enable  
0: Slave mode  
1: Master mode
- BCh.5 **CPOL:** SPI clock polarity  
0: SCK is low in idle state  
1: SCK is high in idle state
- BCh.4 **CPHA:** SPI clock phase  
0: Data sample on first edge of SCK period  
1: Data sample on second edge of SCK period

- BCh.3 **SSDIS**: SS pin disable  
 0: Enable SS pin  
 1: Disable SS pin
- BCh.2 **LSBF**: LSB first  
 0: MSB first  
 1: LSB first
- BCh.1~0 **SPCR**: SPI clock rate  
 00:  $F_{SYSCLK}/2$   
 01:  $F_{SYSCLK}/4$   
 10:  $F_{SYSCLK}/8$   
 11:  $F_{SYSCLK}/16$

SFR BDh	Bit 7	Bit 6	Bit 5	Bit 4	Bit 3	Bit 2	Bit 1	Bit 0
<b>SPSTA</b>	SPIF	WCOL	MODF	RCVOVF	RCVBF	SPBSY	–	–
R/W	R/W	R/W	R/W	R/W	R/W	R/W	–	–
Reset	0	0	0	0	0	0	–	–

- BDh.7 **SPIF**: SPI interrupt flag  
 This is set by H/W at the end of a data transfer. Cleared by H/W when an interrupt is vectored into. Writing 0 to this bit will clear this flag.
- BDh.6 **WCOL**: Write collision interrupt flag  
 Set by H/W if write data to SPDAT when SPBSY is set. Write 0 to this bit or rewrite data to SPDAT when SPBSY is cleared will clear this flag.
- BDh.5 **MODF**: Mode fault interrupt flag  
 Set by H/W when SSDIS is cleared and SS pin is pulled low in Master mode. Write 0 to this bit will clear this flag. When this bit is set, the SPEN and MSTR in SPCON will be cleared by H/W.
- BDh.4 **RCVOVF**: Received buffer overrun flag  
 Set by H/W at the end of a data transfer and RCVBF is set. Write 0 to this bit or read SPDAT register will clear this flag.
- BDh.3 **RCVBF**: Receive buffer full flag  
 Set by H/W at the end of a data transfer. Write 0 to this bit or read SPDAT register will clear this flag.
- BDh.2 **SPBSY**: SPI busy flag  
 Set by H/W when a SPI transfer is in progress.

SFR BEh	Bit 7	Bit 6	Bit 5	Bit 4	Bit 3	Bit 2	Bit 1	Bit 0
<b>SPDAT</b>	SPDAT							
R/W	R/W							
Reset	0	0	0	0	0	0	0	0

- BEh.7~0 **SPDAT**: SPI transmit and receive data  
 The SPDAT register is used to transmit and receive data. Writing data to SPDAT place the data into shift register and start a transfer when in master mode. Reading SPDAT returns the contents of the receive buffer.

## 14. In Circuit Emulation (ICE) Mode

This device can support the In Circuit Emulation Mode. To use the ICE Mode, user just needs to connect P3.0 and P3.1 pin to the tenx proprietary EV Module. The benefit is that user can emulate the whole system without changing the on board target device. But there are some limits for the ICE mode as below.

1. The device must be un-protect.
2. The device's P3.0 and P3.1 pins must work in input Mode (P3MOD0=0/1 and P3MOD1=0/1).
3. During Program Code download, P3.3 sent acknowledge signal to T-Link unit. After download stage, P3.3 can be emulated as any other pins.
4. The Program Memory's addressing space 0D00h~0FFFh and 0033h~003Ah are occupied by tenx EV Module. So user Program cannot access these spaces.
5. The P3.0 and P3.1 pin's function cannot be emulated.

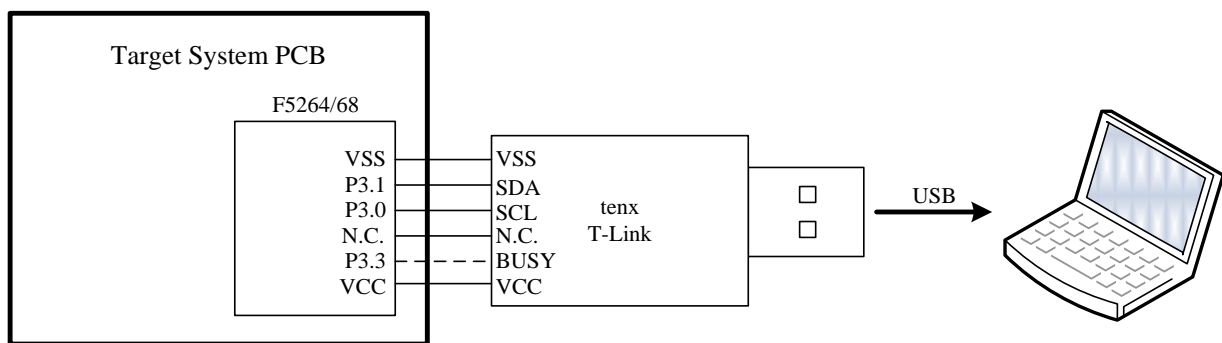

**SFR & CFGW MAP**

Adr	Rst	Name	Bit 7	Bit 6	Bit 5	Bit 4	Bit 3	Bit 2	Bit 1	Bit 0
80h	1111-1111	<b>P0</b>	P0.7	P0.6	P0.5	P0.4	P0.3	P0.2	P0.1	P0.0
81h	0000-0111	<b>SP</b>	SP							
82h	0000-0000	<b>DPL</b>	DPL							
83h	0000-0000	<b>DPH</b>	DPH							
87h	0xxx-0000	<b>PCON</b>	SMOD	-	-	-	GF1	GF0	PD	IDL
88h	0000-0000	<b>TCON</b>	TF1	TR1	TF0	TR0	IE1	IT1	IE0	IT0
89h	0000-0000	<b>TMOD</b>	GATE1	CT1N	TMOD1		GATE0	CT0N	TMOD0	
8Ah	0000-0000	<b>TL0</b>	TL0							
8Bh	0000-0000	<b>TL1</b>	TL1							
8Ch	0000-0000	<b>TH0</b>	TH0							
8Dh	0000-0000	<b>TH1</b>	TH1							
90h	1111-1111	<b>P1</b>	P1.7	P1.6	P1.5	P1.4	P1.3	P1.2	P1.1	P1.0
91h	xxxx-0000	<b>P0OE</b>	-	-	-	-	P0OE			
93h	xxxx-0101	<b>P2MOD</b>	-	-	-	-	P2MOD1		P2MOD0	
94h	0000-0000	<b>OPTION</b>	UART1W	MODE3V	WDTPSC		ADCKS		TM3PSC	
95h	xx00-x000	<b>INTFLG</b>	LVDO	-	TKIF	ADIF	-	IE2	P1IF	TF3
96h	0000-0000	<b>P1WKUP</b>	P1WKUP							
97h	xxxx-xxx0	<b>SWCMD</b>	IAPALL / SWRST							
98h	0000-0000	<b>SCON</b>	SM0	SM1	SM2	REN	TB8	RB8	TI	RI
99h	xxxx-xxxx	<b>SBUF</b>	SBUF							
9Ah	1111-1111	<b>PWM0PRD</b>	PWM0PRD							
9Bh	1000-0000	<b>PWM0DH</b>	PWM0DH							
9Ch	1111-1111	<b>PWM1PRD</b>	PWM1PRD							
9Dh	1000-0000	<b>PWM1DH</b>	PWM1DH							
A0h	1111-1111	<b>P2</b>	P2.7	P2.6	P2.5	P2.4	P2.3	P2.2	P2.1	P2.0
A1h	1000-1000	<b>PWMCON</b>	PWM1CKS		PWM1DL		PWM0CKS		PWM0DL	
A2h	0000-0000	<b>P1MODL</b>	P1MOD3		P1MOD2		P1MOD1		P1MOD0	
A3h	0000-0000	<b>P1MODH</b>	P1MOD7		P1MOD6		P1MOD5		P1MOD4	
A4h	0101-0101	<b>P3MODL</b>	P3MOD3		P3MOD2		P3MOD1		P3MOD0	
A5h	0x00-0000	<b>P3MODH</b>	T0OE	-	P3MOD6		P3MOD5		P3MOD4	
A6h	0x0x-00xx	<b>PINMOD</b>	PWM1OE	-	PWM0OE	-	TCOE	T2OE	-	-
A8h	0x00-0000	<b>IE</b>	EA	-	ET2	ES	ET1	EX1	ET0	EX0
A9h	0000-0000	<b>INTE1</b>	IAPWE			SPIE	ADTKIE	EX2	P1IE	TM3IE
AAh	xxxx-xxxx	<b>ADTKDT</b>	ADC DL				TKEOC	TKOVF	TKDH	
ABh	xxxx-xxxx	<b>ADC DH</b>	ADC DH							
ACh	xxxx-xxxx	<b>TKDL</b>	TKDL							
ADh	1xxx-x100	<b>TKCON</b>	TKPD	-	-	-	-	TKTMR		
A Eh	1111-1111	<b>CHSEL</b>	ADCHS				TKCHS			
A Fh	xxxx-0011	<b>TKCON2</b>	ATKDT				TKAUTO	ATKRATE	ATKNUM	
B0h	1111-1111	<b>P3</b>	P3.7	P3.6	P3.5	P3.4	P3.3	P3.2	P3.1	P3.0
B8h	xx00-0000	<b>IP</b>	-	-	PT2	PS	PT1	PX1	PT0	PX0
B9h	xx00-0000	<b>IPH</b>	-	-	PT2H	PSH	PT1H	PX1H	PT0H	PX0H
BAh	xxx0-0000	<b>IP1</b>	-	-	-	PSPI	PADTKI	PX2	PP1	PT3
BBh	xxx0-0000	<b>IP1H</b>	-	-	-	PSPIH	PADTKIH	PX2H	PP1H	PT3H
BCh	0000-0000	<b>SPCON</b>	SPEN	MSTR	CPOL	CPHA	SSDIS	LSBF	SPCR	
BDh	0000-0xxx	<b>SPSTA</b>	SPIF	WCOL	MODF	RCVOVF	RCVBF	SPBSY	-	-

Adr	Rst	Name	Bit 7	Bit 6	Bit 5	Bit 4	Bit 3	Bit 2	Bit 1	Bit 0
BEh	0000-0000	<b>SPDAT</b>	SPDAT							
C2h	x000-x000	<b>ATKC10H</b>	-	ATKC1H			-	ATKC0H		
C3h	x000-x000	<b>ATKC32H</b>	-	ATKC3H			-	ATKC2H		
C4h	0100-0000	<b>ATKC0L</b>	ATKC0L							
C5h	0100-0000	<b>ATKC1L</b>	ATKC1L							
C6h	0100-0000	<b>ATKC2L</b>	ATKC2L							
C7h	0100-0000	<b>ATKC3L</b>	ATKC3L							
C8h	0000-0000	<b>T2CON</b>	TF2	EXF2	RCLK	TCLK	EXEN2	TR2	CT2N	CPRL2N
CAh	0000-0000	<b>RCP2L</b>	RCP2L							
CBh	0000-0000	<b>RCP2H</b>	RCP2H							
CCh	0000-0000	<b>TL2</b>	TL2							
CDh	0000-0000	<b>TH2</b>	TH2							
D0h	0000-0000	<b>PSW</b>	CY	AC	F0	RS1	RS0	OV	F1	P
D8h	00x0-0011	<b>CLKCON</b>	SCKTYPE	FCKTYPE	-	STPPCK	STPFCK	SELFCK	CLKPSC	
E0h	0000-0000	<b>ACC</b>	ACC.7	ACC.6	ACC.5	ACC.4	ACC.3	ACC.2	ACC.1	ACC.0
F0h	0000-0000	<b>B</b>	B.7	B.6	B.5	B.4	B.3	B.2	B.1	B.0
F7h	xxxx-xxxx	<b>CFGWL</b>	WDTE		-	FRCF				
F8h	0000-0xx0	<b>AUX1</b>	CLRWDT	CLRTM3	TKSOC	ADSOC	CLRPWM0	-	-	DPSEL

Flash Address	Name	Bit 7	Bit 6	Bit 5	Bit 4	Bit 3	Bit 2	Bit 1	Bit 0
1FFEh	<b>CFGWL</b>	-	-	-	FRCF				
1FFFh	<b>CFGWH</b>	PROT	XRSTE	LVRE		VCCFLT	PWRSVAV	MVCLOCK	-

**cSFR & CFGW DESCRIPTION**

SFR Adr	SFR Name	Bit #	Bit Name	R/W	Rst	Description
80h	P0	7~0	P0	R/W	FFh	Port0 data, also controls the P0.n pin's pull-up function. If the P0.n SFR data is "1" and the corresponding P0OE.n=0 (input mode), the pull-up is enabled.
81h	SP	7~0	SP	R/W	07h	Stack Point
82h	DPL	7~0	DPL	R/W	00h	Data Point low byte
83h	DPH	7~0	DPH	R/W	00h	Data Point high byte
87h	PCON	7	SMOD	R/W	0	UART double baud rate control bit 0: Disable UART double baud rate 1: Enable UART double baud rate
		3	GF1	R/W	0	General purpose flag bit
		2	GF0	R/W	0	General purpose flag bit
		1	PD	R/W	0	Stop bit. If 1 Stop mode is entered.
		0	IDL	R/W	0	Idle bit. If 1, Idle mode is entered.
88h	TCON	7	TF1	R/W	0	Timer1 overflow flag Set by H/W when Timer/Counter 1 overflows. Cleared by H/W when CPU vectors into the interrupt service routine.
		6	TR1	R/W	0	Timer1 run control 0: Timer1 stops 1: Timer1 runs
		5	TF0	R/W	0	Timer0 overflow flag Set by H/W when Timer/Counter 0 overflows. Cleared by H/W when CPU vectors into the interrupt service routine.
		4	TR0	R/W	0	Timer0 run control 0: Timer0 stops 1: Timer0 runs
		3	IE1	R/W	0	External Interrupt 1 (INT1 pin) edge flag Set by H/W when an INT1 pin falling edge is detected, no matter the EX1 is 0 or 1. It is cleared automatically when the program performs the interrupt service routine.
		2	IT1	R/W	0	External Interrupt 1 control bit 0: Low level active (level triggered) for INT1 pin 1: Falling edge active (edge triggered) for INT1 pin
		1	IE0	R/W	0	External Interrupt 0 (INT0 pin) edge flag Set by H/W when an INT0 pin falling edge is detected, no matter the EX0 is 0 or 1. It is cleared automatically when the program performs the interrupt service routine.
		0	IT0	R/W	0	External Interrupt 0 control bit 0: Low level active (level triggered) for INT0 pin 1: Falling edge active (edge triggered) for INT0 pin
89h	TMOD	7	GATE1	R/W	0	Timer1 gating control bit 0: Timer1 enable when TR1 bit is set 1: Timer1 enable only while the INT1 pin is high and TR1 bit is set
		6	CT1N	R/W	0	Timer1 Counter/Timer select bit 0: Timer mode, Timer1 data increases at 2 System clock cycle rate 1: Counter mode, Timer1 data increases at T1 pin's negative edge

SFR Adr	SFR Name	Bit #	Bit Name	R/W	Rst	Description
89h	TMOD	5~4	TMOD1	R/W	00	Timer1 mode select 00: 8-bit timer/counter (TH1) and 5-bit prescaler (TL1) 01: 16-bit timer/counter 10: 8-bit auto-reload timer/counter (TL1). Reloaded from TH1 at overflow. 11: Timer1 stops
		3	GATE0	R/W	0	Timer0 gating control bit 0: Timer0 enable when TR0 bit is set 1: Timer0 enable only while the INT0 pin is high and TR0 bit is set
		2	CT0N	R/W	0	Timer0 Counter/Timer select bit 0: Timer mode, Timer0 data increases at 2 System clock cycle rate 1: Counter mode, Timer0 data increases at T0 pin's negative edge
		1~0	TMOD0	R/W	00	Timer0 mode select 00: 8-bit timer/counter (TH0) and 5-bit prescaler (TL0) 01: 16-bit timer/counter 10: 8-bit auto-reload timer/counter (TL0). Reloaded from TH0 at overflow. 11: TL0 is an 8-bit timer/counter. TH0 is an 8-bit timer/counter using Timer1's TR1 and TF1 bits.
8Ah	TL0	7~0	TL0	R/W	00h	Timer0 data low byte
8Bh	TL1	7~0	TL1	R/W	00h	Timer1 data low byte
8Ch	TH0	7~0	TH0	R/W	00h	Timer0 data high byte
8Dh	TH1	7~0	TH1	R/W	00h	Timer1 data high byte
90h	P1	7~0	P1	R/W	FFh	Port1 data
91h	P0OE	3~0	P0OE	R/W	0h	P0.3~P0.0 CMOS Push-Pull output enable control 0: Disable 1: Enable
93h	P2MOD	3~2	P2MOD1	R/W	01	P2.1 pin control
		1~0	P2MOD0	R/W	01	P2.0 pin control
94h	OPTION	7	UART1W	R/W	0	One wire UART mode enable, both TXD/RXD use P3.1 pin 0: Disable one wire UART mode 1: Enable one wire UART mode
		6	MODE3V	R/W	0	3V mode selection control bit If this bit is set, the chip can be only operated in the condition of $V_{CC} < 3.6V$ , and LDO is turned off to save current
		5~4	WDTPSC	R/W	00	Watchdog Timer pre-scalar time select 00: 360ms WDT overflow rate 01: 180ms WDT overflow rate 10: 90ms WDT overflow rate 11: 45ms WDT overflow rate
		3~2	ADCKS	R/W	00	ADC clock rate select 00: $F_{SYSCLK}/32$ 01: $F_{SYSCLK}/16$ 10: $F_{SYSCLK}/8$ 11: $F_{SYSCLK}/4$

SFR Adr	SFR Name	Bit #	Bit Name	R/W	Rst	Description
94h	OPTION	1~0	TM3PSC	R/W	00	Timer3 interrupt rate control select 00: Interrupt rate is 32768 Slow clock cycle 01: Interrupt rate is 16384 Slow clock cycle 10: Interrupt rate is 8192 Slow clock cycle 11: Interrupt rate is 128 Slow clock cycle
95h	INTFLG	7	LVDO	R		Low Voltage Detect flag Set by H/W when a low voltage occurs. The flag is valid when LVR is 2.0V. This flag is disabled in Stop mode or if MODE3V=1 and PWRSAV=1.
		5	TKIF	R/W	0	Touch Key interrupt flag In the S/W Manual mode: Set by H/W at the end of conversion. S/W writes DFh to INTFLG or sets the TKSOC bit to clear this flag. In the ATK mode: Set by H/W when a TK channel's touch event is detected. It is cleared automatically when the program performs the interrupt service routine. S/W can write DFh to INTFLG to clear this bit. <b>Note:</b> In ATK mode, this flag may be cleared improperly by ADC module. User should not start the ADC conversion in ATK mode.
		4	ADIF	R/W	0	ADC interrupt flag Set by H/W at the end of conversion. S/W writes EFh to INTFLG or sets the ADSOC bit to clear this flag.
		2	IE2	R/W	0	External Interrupt 2 (INT2 pin) edge flag Set by H/W when a falling edge is detected on the INT2 pin state, no matter the EX2 is 0 or 1. It is cleared automatically when the program performs the interrupt service routine. S/W can write FBh to INTFLG to clear this bit.
		1	P1IF	R/W	0	Port1 pin change interrupt flag Set by H/W when a P1 pin state change is detected, and its interrupt enable bit is set (P1WKUP). P1IE does not affect this flag's setting. It is cleared automatically when the program performs the interrupt service routine. S/W can write FDh to INTFLG to clear this bit.
		0	TF3	R/W	0	Timer 3 interrupt flag Set by H/W when Timer3 reaches TM3PSC setting cycles. It is cleared automatically when the program performs the interrupt service routine. S/W can write Feh to INTFLG to clear this bit.
96h	P1WKUP	7~0	P1WKUP	R/W	00h	P1.7~P1.0 pin individual Wake up/Interrupt enable control 0: Disable 1: Enable
97h	SWCMD	7~0	SWRST	W		Write 56h to generate S/W Reset
		7~0	IAPALL	W		Write 65h to set IAPALL control flag; Write other value to clear IAPALL flag. It is recommended to clear it immediately after IAP access.
		0	IAPALL	R	0	Flag indicates Flash memory sectors can be accessed by IAP or not. This bit combines with MVCLOCK to define the accessible IAP area.



SFR Adr	SFR Name	Bit #	Bit Name	R/W	Rst	Description
98h	SCON	7	SM0	R/W	0	Serial port mode select bit 0,1 00: Mode0: 8 bit shift register, Baud Rate= $F_{SYSCLK}/2$ 01: Mode1: 8 bit UART, Baud Rate is variable 10: Mode2: 9 bit UART, Baud Rate= $F_{SYSCLK}/32$ or $/64$ 11: Mode3: 9 bit UART, Baud Rate is variable
		6	SM1	R/W	0	
		5	SM2	R/W	0	Serial port mode select bit 2 SM2 enables multiprocessor communication over a single serial line and modifies the above as follows. In Modes 2 & 3, if SM2 is set then the received interrupt will not be generated if the received ninth data bit is 0. In Mode 1, the received interrupt will not be generated unless a valid stop bit is received. In Mode 0, SM2 should be 0.
		4	REN	R/W	0	UART reception enable 0: Disable reception 1: Enable reception
		3	TB8	R/W	0	Transmit Bit 8, the ninth bit to be transmitted in Mode 2 and 3
		2	RB8	R/W	0	Receive Bit 8, contains the ninth bit that was received in Mode 2 and 3 or the stop bit in Mode 1 if SM2=0
		1	TI	R/W	0	Transmit interrupt flag Set by H/W at the end of the eighth bit in Mode 0, or at the beginning of the stop bit in other modes. Must be cleared by S/W.
		0	RI	R/W	0	Receive interrupt flag Set by H/W at the end of the eighth bit in Mode 0, or at the sampling point of the stop bit in other modes. Must be cleared by S/W.
99h	SBUF	7~0	SBUF	R/W		UART transmit and receive data. Transmit data is written to this location and receive data is read from this location, but the paths are independent.
9Ah	PWM0PRD	7~0	PWM0PRD	R/W	FFh	PWM0 8-bit period register
9Bh	PWM0DH	7~0	PWM0DH	R/W	80h	bits 9~2 of the PWM0 10-bit duty register
9Ch	PWM1PRD	7~0	PWM1PRD	R/W	FFh	PWM1 8-bit period register
9Dh	PWM1DH	7~0	PWM1DH	R/W	80h	bits 9~2 of the PWM1 10-bit duty register
A0h	P2	7~0	P2	R/W	FFh	Port2 data, also controls the P2.n pin's pull-up function. If the P2.n SFR data is "1" and the corresponding P2OE.n=0 (input mode), the pull-up is enabled.
A1h	PWMCON	7~6	PWM1CKS	R/W	10	PWM1 clock source 00: $F_{SYSCLK}/4$ 01: $F_{SYSCLK}/2$ 10: $F_{SYSCLK}$ 11: FRCx2
		5~4	PWM1DL	R/W	00	bits 1~0 of the PWM1 10-bit duty register
		3~2	PWM0CKS	R/W	10	PWM0 clock source 00: $F_{SYSCLK}/4$ 01: $F_{SYSCLK}/2$ 10: $F_{SYSCLK}$ 11: FRCx2
		1~0	PWM0DL	R/W	00	bits 1~0 of the PWM0 10-bit duty register
A2h	P1MODL	7~6	P1MOD3	R/W	00	P1.3 pin control
		5~4	P1MOD2	R/W	00	P1.2 pin control
		3~2	P1MOD1	R/W	00	P1.1 pin control
		1~0	P1MOD0	R/W	00	P1.0 pin control

SFR Adr	SFR Name	Bit #	Bit Name	R/W	Rst	Description
A3h	P1MODH	7~6	P1MOD7	R/W	00	P1.7 pin control
		5~4	P1MOD6	R/W	00	P1.6 pin control
		3~2	P1MOD5	R/W	00	P1.5 pin control
		1~0	P1MOD4	R/W	00	P1.4 pin control
A4h	P3MODL	7~6	P3MOD3	R/W	01	P3.3 pin control
		5~4	P3MOD2	R/W	01	P3.2 pin control
		3~2	P3MOD1	R/W	01	P3.1 pin control
		1~0	P3MOD0	R/W	01	P3.0 pin control
A5h	P3MODH	7	T0OE	R/W	0	Timer0 signal output (T0O) control 0: Disable Timer0 overflow divided by 64 output to P3.4 1: Enable Timer0 overflow divided by 64 output to P3.4
		5~4	P3MOD6	R/W	00	P3.6 pin control
		3~2	P3MOD5	R/W	00	P3.5 pin control
		1~0	P3MOD4	R/W	00	P3.4 pin control
A6h	PINMOD	7	PWM1OE	R/W	0	PWM1 signal output enable 0: Disable PWM1 signal output to P1.3 1: Enable PWM1 signal output to P1.3
		5	PWM0OE	R/W	0	PWM0 signal output enable 0: Disable PWM0 signal output to P1.2 1: Enable PWM0 signal output to P1.2
		3	TCOE	R/W	0	TCOE: System clock signal output (CKO) control 0: Disable System clock divided by 2 output to P1.4 1: Enable System clock divided by 2 output to P1.4
		2	T2OE	R/W	0	Timer2 signal output (T2O) enable 0: Disable Timer2 overflow divided by 2 output to P1.0 1: Enable Timer2 overflow divided by 2 output to P1.0
A8h	IE	7	EA	R/W	0	Global interrupt enable 0: Disable all interrupts 1: Each interrupt is enabled or disabled by its individual interrupt control bit
		5	ET2	R/W	0	Timer2 interrupt enable 0: Disable Timer2 interrupt 1: Enable Timer2 interrupt
		4	ES	R/W	0	Serial Port (UART) interrupt enable 0: Disable Serial Port (UART) interrupt 1: Enable Serial Port (UART) interrupt
		3	ET1	R/W	0	Timer1 interrupt enable 0: Disable Timer1 interrupt 1: Enable Timer1 interrupt
		2	EX1	R/W	0	INT1 pin Interrupt enable and Stop mode wake up enable 0: Disable INT1 pin Interrupt and Stop mode wake up 1: Enable INT1 pin Interrupt and Stop mode wake up, it can wake up CPU from Stop mode no matter EA is 0 or 1.
		1	ET0	R/W	0	Timer0 interrupt enable 0: Disable Timer0 interrupt 1: Enable Timer0 interrupt
		0	EX0	R/W	0	INT0 pin Interrupt enable and Stop mode wake up enable 0: Disable INT0 pin Interrupt and Stop mode wake up 1: Enable INT0 pin Interrupt and Stop mode wake up, it can wake up CPU from Stop mode no matter EA is 0 or 1.

SFR Adr	SFR Name	Bit #	Bit Name	R/W	Rst	Description
A9h	INTE1	7~5	IAPWE	R/W	000	Set to 101 to enable IAP write. It is recommended to clear it immediately after IAP write.
		4	SPIE	R/W	0	SPI interrupt enable 0: Disable SPI interrupt 1: Enable SPI interrupt
		3	ADTKIE	R/W	0	ADC/Touch Key (F5268 Only) interrupt enable 0: Disable ADC/Touch Key (F5268 Only) interrupt 1: Enable ADC/Touch Key (F5268 Only) interrupt
		2	EX2	R/W	0	INT2 pin Interrupt enable and Stop mode wake up enable 0: Disable INT2 pin Interrupt and Stop mode wake up 1: Enable INT2 pin Interrupt and Stop mode wake up, it can wake up CPU from Stop mode no matter EA is 0 or 1.
		1	P1IE	R/W	0	Port1 pin change interrupt enable 0: Disable Port1 pin change interrupt 1: Enable Port1 pin change interrupt
		0	TM3IE	R/W	0	Timer3 interrupt enable 0: Disable Timer3 interrupt 1: Enable Timer3 interrupt
AAh	ADTKDT	7~4	ADCDL	R		ADC data bit 3~0
		3	TKEOC	R		Touch Key end of conversion flag 0: Indicates conversion is in progress 1: Indicates conversion is finished
		2	TKOVF	R		Touch Key counter overflow 0: Indicates that the counter has not overflow 1: Indicates that the counter has overflow
		1~0	TKDH	R		Touch Key counter data bit 9~8
ABh	ADCDH	7~0	ADCDH	R		ADC data bit 11~4
ACh	TKDL	7~0	TKDL	R		Touch Key counter data bit 7~0
ADh	TKCON	7	TKPD	R/W	1	Touch Key power down 0: Touch Key running 1: Touch Key power down
		2~0	TKTMR	R/W	100	Touch Key conversion time select TKTMR adjusts the value of Touch Key reference voltage. A larger value of TKTMR requires a longer charging time, which can affect the sensitivity of touch sensing. 000: Conversion time shortest ... 111: Conversion time longest

SFR Adr	SFR Name	Bit #	Bit Name	R/W	Rst	Description
AEh	CHSEL	7~4	ADCHS	R/W	1111	ADC channel select 0000: ADC0 (P3.3) 0001: ADC1 (P3.2) 0010: ADC2 (P3.1) 0011: ADC3 (P3.0) 0100: ADC4 (P1.0) 0101: ADC5 (P1.1) 0110: ADC6 (P1.2) 0111: ADC7 (P1.3) 1000: ADC8 (P1.4) 1001: ADC9 (P1.5) 1010: V <sub>SS</sub> 1011: VBG (internal reference voltage) 11xx: Undefined
		3~0	TKCHS	R/W	1111	Touch Key channel select 0000: TK0 (P1.0) 0001: TK1 (P1.1) 0010: TK2 (P1.2) 0011: TK3 (P1.3) 0100: TK4 (P3.3) 0101: TK5 (P3.2) 0110: TK6 (P3.1) 0111: TK7 (P3.0) 1000: TK8 (P1.4) 1001: TK9 (P1.6) 1010: TK10 (P1.7) 1011: TK11 (P3.6) 1100: TK12 (P3.5) 1101: TK13 (P3.4) 1110: Undefined 1111: Internal Bandgap reference capacitor
AFh	TKCON2	7~4	ATKDT	R		Touch Key Auto Scan Result (for H/W ATK Mode) xxx1: TK0 has a Touch event xx1x: TK1 has a Touch event x1xx: TK2 has a Touch event 1xxx: TK3 has a Touch event
		3	TKAUTO	R/W	0	Touch Key Auto Scan Mode Enable 0: S/W Mode 1: H/W ATK Mode
		2	ATKRATE	R/W	0	Touch Key Scan Rate (for H/W ATK Mode) 0: ATK scan rate at every 4096 Slow clock cycles 1: ATK scan rate at every 2048 Slow clock cycles
		1~0	ATKNUM	R/W	11	Touch Key Auto Scan Channel Number (for H/W ATK Mode) 00: ATK only detect TK0 01: ATK detect TK0 and TK1 10: ATK detect TK0~TK2 11: ATK detect TK0~TK3
B0h	P3	7~0	P3	R/W	FFh	Port3 data

SFR Adr	SFR Name	Bit #	Bit Name	R/W	Rst	Description
B8h	IP	5	PT2	R/W	0	Timer2 interrupt priority low bit
		4	PS	R/W	0	Serial Port interrupt priority low bit
		3	PT1	R/W	0	Timer1 interrupt priority low bit
		2	PX1	R/W	0	INT1 interrupt priority low bit
		1	PT0	R/W	0	Timer0 interrupt priority low bit
		0	PX0	R/W	0	INT0 interrupt priority low bit
B9h	IPH	5	PT2H	R/W	0	Timer2 interrupt priority high bit
		4	PSH	R/W	0	Serial Port interrupt priority high bit
		3	PT1H	R/W	0	Timer1 interrupt priority high bit
		2	PX1H	R/W	0	INT1 interrupt priority high bit
		1	PT0H	R/W	0	Timer0 interrupt priority high bit
		0	PX0H	R/W	0	INT0 interrupt priority high bit
BAh	IP1	4	PSPI	R/W	0	SPI interrupt priority low bit
		3	PADTKI	R/W	0	ADC/Touch Key interrupt priority low bit
		2	PX2	R/W	0	INT2 interrupt priority low bit
		1	PP1	R/W	0	Port1 pin change interrupt priority low bit
		0	PT3	R/W	0	Timer3 interrupt priority low bit
BBh	IP1H	4	PSPIH	R/W	0	SPI interrupt priority high bit
		3	PADTKIH	R/W	0	ADC/Touch Key interrupt priority high bit
		2	PX2H	R/W	0	INT2 interrupt priority high bit
		1	PP1H	R/W	0	Port1 interrupt priority high bit
		0	PT3H	R/W	0	Timer3 interrupt priority high bit
BCh	SPCON	7	SPEN	R/W	0	SPI enable 0: SPI disable 1: SPI enable
		6	MSTR	R/W	0	Master mode enable 0: Slave mode 1: Master mode
		5	CPOL	R/W	0	SPI clock polarity 0: SCK is low in idle state 1: SCK is high in idle state
		4	CPHA	R/W	0	SPI clock phase 0: Data sample on first edge of SCK period 1: Data sample on second edge of SCK period
		3	SSDIS	R/W	0	SS pin disable 0: Enable SS pin 1: Disable SS pin
		2	LSBF	R/W	0	LSB first 0: MSB first 1: LSB first
		1~0	SPCR	R/W	00	SPI clock rate 00: F <sub>SYSClk</sub> /2 01: F <sub>SYSClk</sub> /4 10: F <sub>SYSClk</sub> /8 11: F <sub>SYSClk</sub> /16

SFR Adr	SFR Name	Bit #	Bit Name	R/W	Rst	Description
BDh	SPSTA	7	SPIF	R/W	0	SPI interrupt flag This is set by H/W at the end of a data transfer. Cleared by H/W when an interrupt is vectored into. Writing 0 to this bit will clear this flag.
		6	WCOL	R/W	0	Write collision interrupt flag Set by H/W if write data to SPDAT when SPBSY is set. Write 0 to this bit or rewrite data to SPDAT when SPBSY is cleared will clear this flag.
		5	MODF	R/W	0	Mode fault interrupt flag Set by H/W when SSDIS is cleared and SS pin is pulled low in Master mode. Write 0 to this bit will clear this flag. When this bit is set, the SPEN and MSTR in SPCON will be cleared by H/W.
		4	RCVOVF	R/W	0	Received buffer overrun flag Set by H/W at the end of a data transfer and RCVBF is set. Write 0 to this bit or read SPDAT register will clear this flag.
		3	RCVBF	R/W	0	Receive buffer full flag Set by H/W at the end of a data transfer. Write 0 to this bit or read SPDAT register will clear this flag.
		2	SPBSY	R		SPI busy flag Set by H/W when a SPI transfer is in progress.
BEh	SPDAT	7~0	SPDAT	R/W	0	SPI transmit and receive data The SPDAT register is used to transmit and receive data. Writing data to SPDAT place the data into shift register and start a transfer when in master mode. Reading SPDAT returns the contents of the receive buffer.
C2h	ATKC10H	6~4	ATKC1H	R/W	000	Data Threshold bit 10~8 Compared with TK1 scan (for H/W ATK Mode)
		2~0	ATKC0H	R/W	000	Data Threshold bit 10~8 Compared with TK0 scan (for H/W ATK Mode)
C3h	ATKC32H	6~4	ATKC3H	R/W	000	Data Threshold bit 10~8 Compared with TK3 scan (for H/W ATK Mode)
		2~0	ATKC2H	R/W	000	Data Threshold bit 10~8 Compared with TK2 scan (for H/W ATK Mode)
C4h	ATKC0L	7~0	ATKC0L	R/W	40h	Data Threshold bit 7~0 Compared with TK0 scan (for H/W ATK Mode)
C5h	ATKC1L	7~0	ATKC1L	R/W	40h	Data Threshold bit 7~0 Compared with TK1 scan (for H/W ATK Mode)
C6h	ATKC2L	7~0	ATKC2L	R/W	40h	Data Threshold bit 7~0 Compared with TK2 scan (for H/W ATK Mode)
C7h	ATKC3L	7~0	ATKC3L	R/W	40h	Data Threshold bit 7~0 Compared with TK3 scan (for H/W ATK Mode)

SFR Adr	SFR Name	Bit #	Bit Name	R/W	Rst	Description
C8h	T2CON	7	TF2	R/W	0	Timer2 overflow flag Set by H/W when Timer/Counter 2 overflows unless RCLK=1 or TCLK=1. This bit must be cleared by S/W.
		6	EXF2	R/W	0	T2EX interrupt pin falling edge flag Set when a capture or a reload is caused by a negative transition on T2EX pin if EXEN2=1. This bit must be cleared by S/W.
		5	RCLK	R/W	0	UART receive clock control bit 0: Use Timer1 overflow as receive clock for serial port in mode 1 or 3 1: Use Timer2 overflow as receive clock for serial port in mode 1 or 3
		4	TCLK	R/W	0	UART transmit clock control bit 0: Use Timer1 overflow as transmit clock for serial port in mode 1 or 3 1: Use Timer2 overflow as transmit clock for serial port in mode 1 or 3
		3	EXEN2	R/W	0	T2EX pin enable 0: T2EX pin disable 1: T2EX pin enable, it cause a capture or reload when a negative transition on T2EX pin is detected if RCLK=TCLK=0
		2	TR2	R/W	0	Timer2 run control 0: Timer2 stops 1: Timer2 runs
		1	CT2N	R/W	0	Timer2 Counter/Timer select bit 0: Timer mode, Timer2 data increases at 2 System clock cycle rate 1: Counter mode, Timer2 data increases at T2 pin's negative edge
		0	CPRL2N	R/W	0	Timer2 Capture/Reload control bit 0: Reload mode, auto-reload on Timer2 overflows or negative transitions on T2EX pin if EXEN2=1 1: Capture mode, capture on negative transitions on T2EX pin if EXEN2=1 If RCLK=1 or TCLK=1, CPRL2N is ignored and timer is forced to auto-reload on Timer2 overflow
CAh	RCP2L	7~0	RCP2L	R/W	00h	Timer2 reload/capture data low byte
CBh	RCP2H	7~0	RCP2H	R/W	00h	Timer2 reload/capture data high byte
CCh	TL2	7~0	TL2	R/W	00h	Timer2 data low byte
CDh	TH2	7~0	TH2	R/W	00h	Timer2 data high byte
D0h	PSW	7	CY	R/W	0	ALU carry flag
		6	AC	R/W	0	ALU auxiliary carry flag
		5	F0	R/W	0	General purpose user-definable flag
		4	RS1	R/W	0	The contents of (RS1, RS0) enable the working register banks as: 00: Bank 0 (00h~07h) 01: Bank 1 (08h~0Fh) 10: Bank 2 (10h~17h) 11: Bank 3 (18h~1Fh)
		3	RS0	R/W	0	
		2	OV	R/W	0	ALU overflow flag
		1	F1	R/W	0	General purpose user-definable flag
		0	P	R/W	0	Parity flag. Set/cleared by hardware each instruction cycle to indicate odd/even number of "1" bits in the accumulator.

SFR Adr	SFR Name	Bit #	Bit Name	R/W	Rst	Description
D8h	CLKCON	7	SCKTYPE	R/W	0	Slow clock type. This bit can be changed only in Fast mode (SELFCK=1). 0: SRC 1: SXT
		6	FCKTYPE	R/W	0	Fast clock type. This bit can be changed only in Slow mode (SELFCK=0). 0: FRC 1: FXT
		4	STPPCK	R/W	0	Set 1 to stop UART/Timer0/Timer1/Timer2/ADC clock in Idle mode
		3	STPFCK	R/W	0	Set 1 to stop Fast clock for power saving in Slow/Idle mode. This bit can be changed only in Slow mode.
		2	SELFCK	R/W	0	System clock source selection. This bit can be changed only when STPFCK=0. 0: Slow clock 1: Fast clock
		1~0	CLKPSC	R/W	11	System clock prescaler. 00: System clock is Fast/Slow clock divided by 16 01: System clock is Fast/Slow clock divided by 4 10: System clock is Fast/Slow clock divided by 2 11: System clock is Fast/Slow clock divided by 1
E0h	ACC	7~0	ACC	R/W	00h	Accumulator
F0h	B	7~0	B	R/W	00h	B register
F7h	CFGWL	7~6	WDTE	R/W		Watchdog Timer Reset control 0x: Watchdog Timer Reset disable 10: Watchdog Timer Reset enable in Fast/Slow mode, disable in Idle/Stop mode 11: Watchdog Timer Reset always enable
		4~0	FRCF	R/W		Fast RC frequency adjustment
F8h	AUX1	7	CLRWDT	R/W	0	Set to clear WDT, H/W auto clear it at next clock cycle
		6	CLRTM3	R/W	0	Set to clear Timer3, H/W auto clear it at next clock cycle
		5	TKSOC	R/W	0	Start Touch Key conversion Set the TKSOC bit to start Touch Key conversion, and the TKSOC bit will be cleared by H/W at the end of conversion. S/W can also write 0 to clear this flag.
		4	ADSOC	R/W	0	Start ADC conversion Set the ADSOC bit to start ADC conversion, and the ADSOC bit will be cleared by H/W at the end of conversion. S/W can also write 0 to clear this flag.
		3	CLRPWM0	R/W	0	PWM0 clear enable 0: PWM0 is running 1: PWM0 is cleared and held
		0	DPSEL	R/W	0	Active DPTR Select



Flash Adr	Bit #	Name	Description
1FFEh	4~0	FRCF	Fast RC frequency adjustment
1FFFh	7	PROT	Flash Memory Code Protect 0: Disable protect 1: Enable protect
	6	XRSTE	External Pin Reset control 0: Disable External Pin Reset 1: Enable External Pin Reset
	5~4	LVRE	Low Voltage Reset function select 00: Set LVR at 2.9V 01: Set LVR at 2.3V 10: LVR disable and set LVD at 2.3V (F5264B/68B) 11: Set LVR at 1.8V and LVD at 2.3V (F5264B/68B) 1x: Set LVR at 2.0V and LVD at 2.3V (F5264C/68C)
	3	VCCFLT	Set 1 to enhance the chip's power noise immunity
	2	PWRSV	Power save function control bit 0: Disable Power save function 1: Enable Power save function
	1	MVCLOCK	If 1, the MOVC & MOVX instruction's accessibility to MOVC-Lock area is limited.

## INSTRUCTION SET

Instructions are 1, 2 or 3 Bytes long as listed in the 'byte' column below. Each instruction takes 2~8 System clock cycles to execute as listed in the 'cycle' column below.

ARITHMETIC				
Mnemonic	Description	byte	cycle	opcode
ADD A, Rn	Add register to A	1	2	28-2F
ADD A, dir	Add direct byte to A	2	2	25
ADD A, @Ri	Add indirect memory to A	1	2	26-27
ADD A, #data	Add immediate to A	2	2	24
ADDC A, Rn	Add register to A with carry	1	2	38-3F
ADDC A, dir	Add direct byte to A with carry	2	2	35
ADDC A, @Ri	Add indirect memory to A with carry	1	2	36-37
ADDC A, #data	Add immediate to A with carry	2	2	34
SUBB A, Rn	Subtract register from A with borrow	1	2	98-9F
SUBB A, dir	Subtract direct byte from A with borrow	2	2	95
SUBB A, @Ri	Subtract indirect memory from A with borrow	1	2	96-97
SUBB A, #data	Subtract immediate from A with borrow	2	2	94
INC A	Increment A	1	2	04
INC Rn	Increment register	1	2	08-0F
INC dir	Increment direct byte	2	2	05
INC @Ri	Increment indirect memory	1	2	06-07
DEC A	Decrement A	1	2	14
DEC Rn	Decrement register	1	2	18-1F
DEC dir	Decrement direct byte	2	2	15
DEC @Ri	Decrement indirect memory	1	2	16-17
INC DPTR	Increment data pointer	1	4	A3
MUL AB	Multiply A by B	1	8	A4
DIV AB	Divide A by B	1	8	84
DA A	Decimal Adjust A	1	2	D4

LOGICAL				
Mnemonic	Description	byte	cycle	opcode
ANL A, Rn	AND register to A	1	2	58-5F
ANL A, dir	AND direct byte to A	2	2	55
ANL A, @Ri	AND indirect memory to A	1	2	56-57
ANL A, #data	AND immediate to A	2	2	54
ANL dir, A	AND A to direct byte	2	2	52
ANL dir, #data	AND immediate to direct byte	3	4	53
ORL A, Rn	OR register to A	1	2	48-4F
ORL A, dir	OR direct byte to A	2	2	45
ORL A, @Ri	OR indirect memory to A	1	2	46-47
ORL A, #data	OR immediate to A	2	2	44
ORL dir, A	OR A to direct byte	2	2	42
ORL dir, #data	OR immediate to direct byte	3	4	43
XRL A, Rn	Exclusive-OR register to A	1	2	68-6F
XRL A, dir	Exclusive-OR direct byte to A	2	2	65
XRL A, @Ri	Exclusive-OR indirect memory to A	1	2	66-67
XRL A, #data	Exclusive-OR immediate to A	2	2	64
XRL dir, A	Exclusive-OR A to direct byte	2	2	62
XRL dir, #data	Exclusive-OR immediate to direct byte	3	4	63
CLR A	Clear A	1	2	E4
CPL A	Complement A	1	2	F4
SWAP A	Swap Nibbles of A	1	2	C4
RL A	Rotate A left	1	2	23

<b>LOGICAL</b>				
<b>Mnemonic</b>	<b>Description</b>	<b>byte</b>	<b>cycle</b>	<b>opcode</b>
RLC A	Rotate A left through carry	1	2	33
RR A	Rotate A right	1	2	03
RRC A	Rotate A right through carry	1	2	13

<b>DATA TRANSFER</b>				
<b>Mnemonic</b>	<b>Description</b>	<b>byte</b>	<b>cycle</b>	<b>opcode</b>
MOV A, Rn	Move register to A	1	2	E8-EF
MOV A, dir	Move direct byte to A	2	2	E5
MOV A, @Ri	Move indirect memory to A	1	2	E6-E7
MOV A, #data	Move immediate to A	2	2	74
MOV Rn, A	Move A to register	1	2	F8-FF
MOV Rn, dir	Move direct byte to register	2	4	A8-AF
MOV Rn, #data	Move immediate to register	2	2	78-7F
MOV dir, A	Move A to direct byte	2	2	F5
MOV dir, Rn	Move register to direct byte	2	4	88-8F
MOV dir, dir	Move direct byte to direct byte	3	4	85
MOV dir, @Ri	Move indirect memory to direct byte	2	4	86-87
MOV dir, #data	Move immediate to direct byte	3	4	75
MOV @Ri, A	Move A to indirect memory	1	2	F6-F7
MOV @Ri, dir	Move direct byte to indirect memory	2	4	A6-A7
MOV @Ri, #data	Move immediate to indirect memory	2	2	76-77
MOV DPTR, #data	Move immediate to data pointer	3	4	90
MOVC A, @A+DPTR	Move code byte relative DPTR to A	1	4	93
MOVC A, @A+PC	Move code byte relative PC to A	1	4	83
MOVX A, @Ri	Move external data (A8) to A	1	4	E2-E3
MOVX A, @DPTR	Move external data (A16) to A	1	4	E0
MOVX @Ri, A	Move A to external data (A8)	1	4	F2-F3
MOVX @DPTR, A	Move A to external data (A16)	1	4	F0
PUSH dir	Push direct byte onto stack	2	4	C0
POP dir	Pop direct byte from stack	2	4	D0
XCH A, Rn	Exchange A and register	1	2	C8-CF
XCH A, dir	Exchange A and direct byte	2	2	C5
XCH A, @Ri	Exchange A and indirect memory	1	2	C6-C7
XCHD A, @Ri	Exchange A and indirect memory nibble	1	2	D6-D7

<b>BOOLEAN</b>				
<b>Mnemonic</b>	<b>Description</b>	<b>byte</b>	<b>cycle</b>	<b>opcode</b>
CLR C	Clear carry	1	2	C3
CLR bit	Clear direct bit	2	2	C2
SETB C	Set carry	1	2	D3
SETB bit	Set direct bit	2	2	D2
CPL C	Complement carry	1	2	B3
CPL bit	Complement direct bit	2	2	B2
ANL C, bit	AND direct bit to carry	2	4	82
ANL C, /bit	AND direct bit inverse to carry	2	4	B0
ORL C, bit	OR direct bit to carry	2	4	72
ORL C, /bit	OR direct bit inverse to carry	2	4	A0
MOV C, bit	Move direct bit to carry	2	2	A2
MOV bit, C	Move carry to direct bit	2	4	92

<b>BRANCHING</b>				
<b>Mnemonic</b>	<b>Description</b>	<b>byte</b>	<b>cycle</b>	<b>opcode</b>
ACALL addr 11	Absolute jump to subroutine	2	4	11-F1
LCALL addr 16	Long jump to subroutine	3	4	12
RET	Return from subroutine	1	4	22
RETI	Return from interrupt	1	4	32
AJMP addr 11	Absolute jump unconditional	2	4	01-E1
LJMP addr 16	Long jump unconditional	3	4	02
SJMP rel	Short jump (relative address)	2	4	80
JC rel	Jump on carry=1	2	4	40
JNC rel	Jump on carry=0	2	4	50
JB bit, rel	Jump on direct bit=1	3	4	20
JNB bit, rel	Jump on direct bit=0	3	4	30
JBC bit, rel	Jump on direct bit=1 and clear	3	4	10
JMP @A+DPTR	Jump indirect relative DPTR	1	4	73
JZ rel	Jump on accumulator=0	2	4	60
JNZ rel	Jump on accumulator...0	2	4	70
CJNE A, dir, rel	Compare A,direct, jump not equal relative	3	4	B5
CJNE A, #data, rel	Compare A,immediate, jump not equal relative	3	4	B4
CJNE Rn, #data, rel	Compare register,immediate, jump not equal relative	3	4	B8-BF
CJNE @Ri, #data, rel	Compare indirect,immediate, jump not equal relative	3	4	B6-B7
DJNZ Rn, rel	Decrement register, jump not zero relative	2	4	D8-DF
DJNZ dir, rel	Decrement direct byte, jump not zero relative	3	4	D5

<b>MISCELLANEOUS</b>				
<b>Mnemonic</b>	<b>Description</b>	<b>byte</b>	<b>cycle</b>	<b>opcode</b>
NOP	No operation	1	2	00

In the above table, an entry such as E8-EF indicates a continuous block of hex opcodes used for 8 different registers, the register numbers of which are defined by the lowest three bits of the corresponding code. Non-continuous blocks of codes, shown as 11-F1 (for example), are used for absolute jumps and calls with the top 3 bits of the code being used to store the top three bits of the destination address.

## ELECTRICAL CHARACTERISTICS

### 1. Absolute Maximum Ratings ( $T_A=25^\circ\text{C}$ )

Parameter	Rating	Unit	
Supply voltage	$V_{SS}-0.3 \sim V_{SS}+5.5$	V	
Input voltage	$V_{SS}-0.3 \sim V_{CC}+0.3$		
Output voltage	$V_{SS}-0.3 \sim V_{CC}+0.3$		
Output current high per 1 PIN	-25	mA	
Output current high per all PIN	-80		
Output current low per 1 PIN	+30		
Output current low per all PIN	+150		
Maximum Operating Voltage	5.5	V	
Operating temperature	TM52F5264B/68B	-20 ~ +70	°C
	TM52F5264C/68C	-40 ~ +85	
Storage temperature	-65 ~ +150		

### 2. DC Characteristics ( $T_A=25^\circ\text{C}$ , $V_{CC}=2.0\text{V} \sim 5.5\text{V}$ )

Parameter	Symbol	Conditions	Min.	Typ.	Max.	Unit	
Operating Voltage	$V_{CC}$	Fast mode, $F_{SYSCLK}=7.3728\text{ MHz}$	2.9	-	5.5	V	
		Fast mode, $F_{SYSCLK}=3.6864\text{ MHz}$	2.3	-	5.5		
		Fast mode, $F_{SYSCLK}=1.8432\text{ MHz}$	1.8	-	5.5		
		Fast mode, $F_{SYSCLK}=0.4608\text{ MHz}$	1.8	-	5.5		
		Slow mode, SRC	1.8	-	5.5		
Input High Voltage	$V_{IH}$	All Input, except P3.7, P2.1	$V_{CC}=5\text{V}$	$0.6V_{CC}$	-	-	V
			$V_{CC}=3\text{V}$	$0.6V_{CC}$	-	-	
		P3.7, P2.1	$V_{CC}=5\text{V}$	$0.8V_{CC}$	-	-	
			$V_{CC}=3\text{V}$	$0.8V_{CC}$	-	-	
Input Low Voltage	$V_{IL}$	All Input	$V_{CC}=5\text{V}$	-	-	$0.2V_{CC}$	V
			$V_{CC}=3\text{V}$	-	-	$0.2V_{CC}$	
I/O Port Source Current	$I_{OH}$	All Output, except P3.7	$V_{CC}=5\text{V}$ $V_{OH}=0.9V_{CC}$	6	12	-	mA
			$V_{CC}=3\text{V}$ $V_{OH}=0.9V_{CC}$	2.5	5	-	
I/O Port Sink Current	$I_{OL}$	All Output, except P0.0~P0.3	$V_{CC}=5\text{V}$ $V_{OL}=0.1V_{CC}$	12	24	-	mA
			$V_{CC}=3\text{V}$ $V_{OL}=0.1V_{CC}$	6	12	-	
		P0.0~P0.3	$V_{CC}=5\text{V}$ $V_{OL}=0.1V_{CC}$	35	70	-	
			$V_{CC}=3\text{V}$ $V_{OL}=0.1V_{CC}$	20	40	-	
Input Leakage Current (pin high)	$I_{ILH}$	All Input	$V_{in}=V_{CC}$	-	-	1	$\mu\text{A}$
Input Leakage Current (pin low)	$I_{ILL}$	All Input	$V_{in}=0\text{V}$	-	-	-1	

Parameter	Symbol	Conditions	Min.	Typ.	Max.	Unit	
Supply Current (TM52F5268B) (TM52F5264B)	I <sub>CC</sub>	Fast, V <sub>CC</sub> =5V LVR enable MODE3V=0	FXT=8 MHz	–	3.6	–	mA
			FRC=7.3728 MHz	–	3	–	
			FRC=3.6864 MHz	–	1.8	–	
		Fast, V <sub>CC</sub> =3V LVR enable MODE3V=0	FXT=8 MHz	–	2.6	–	
			FRC=7.3728 MHz	–	2.5	–	
			FRC=3.6864 MHz	–	1.5	–	
		Fast, V <sub>CC</sub> =3V LVR enable MODE3V=1	FXT=8 MHz	–	2.5	–	
			FRC=7.3728 MHz	–	2.3	–	
			FRC=3.6864 MHz	–	1.4	–	
		Slow, V <sub>CC</sub> =5V LVR enable MODE3V=0	SXT=32 KHz	–	200	–	μA
			SRC=24 KHz	–	180	–	
		Slow, V <sub>CC</sub> =3V LVR enable MODE3V=0	SXT=32 KHz	–	160	–	
			SRC=24 KHz	–	150	–	
		Slow, V <sub>CC</sub> =3V MODE3V=1 PWRSV=1	SXT=32 KHz	–	13	–	
			SRC=24 KHz	–	9	–	
		Slow, V <sub>CC</sub> =3V MODE3V=1 PWRSV=0	SXT=32 KHz	–	47	–	
			SRC=24 KHz	–	45	–	
		Idle, V <sub>CC</sub> =5V LVR enable MODE3V=0	SXT=32 KHz	–	180	–	
			SRC=24 KHz	–	175	–	
		Idle, V <sub>CC</sub> =3V LVR enable MODE3V=0	SXT=32 KHz	–	148	–	
			SRC=24 KHz	–	147	–	
		Idle, V <sub>CC</sub> =3V MODE3V=1 PWRSV=1	SXT=32 KHz	–	5	–	
			SRC=24 KHz	–	3	–	
		Idle, V <sub>CC</sub> =3V MODE3V=1 PWRSV=0	SXT=32 KHz	–	40	–	
			SRC=24 KHz	–	38	–	
		Stop, V <sub>CC</sub> =5V LVR disable MODE3V=0	PWRSV=1	–	0.1	–	
			PWRSV=0	–	140	–	
Stop, V <sub>CC</sub> =3V LVR disable MODE3V=0	PWRSV=1	–	–	0.1			
	PWRSV=0	–	120	–			
Stop, V <sub>CC</sub> =5V LVR enable MODE3V=0	PWRSV=1	–	1.4	–			
	PWRSV=0	–	170	–			
Stop, V <sub>CC</sub> =3V LVR enable MODE3V=0	PWRSV=1	–	0.5	–			
	PWRSV=0	–	145	–			
Stop, V <sub>CC</sub> =3V MODE3V=1	LVR disable	–	–	0.1			
	LVR enable PWRSV=1	–	0.5	–			
	LVR enable PWRSV=0	–	36	–			

Parameter	Symbol	Conditions	Min.	Typ.	Max.	Unit	
Supply Current (TM52F5268C) (TM52F5264C)	I <sub>CC</sub>	Fast, V <sub>CC</sub> =5V MODE3V=0	FXT=8 MHz	–	3.6	–	mA
			FRC=7.3728 MHz	–	3	–	
			FRC=3.6864 MHz	–	1.8	–	
		Fast, V <sub>CC</sub> =3V MODE3V=0	FXT=8 MHz	–	2.6	–	
			FRC=7.3728 MHz	–	2.5	–	
			FRC=3.6864 MHz	–	1.5	–	
		Fast, V <sub>CC</sub> =3V MODE3V=1	FXT=8 MHz	–	2.5	–	
			FRC=7.3728 MHz	–	2.3	–	
			FRC=3.6864 MHz	–	1.4	–	
		Slow, V <sub>CC</sub> =5V MODE3V=0	SXT=32 KHz	–	200	–	μA
			SRC=24 KHz	–	180	–	
		Slow, V <sub>CC</sub> =3V MODE3V=0	SXT=32 KHz	–	160	–	
			SRC=24 KHz	–	150	–	
		Slow, V <sub>CC</sub> =3V MODE3V=1 PWRSV=1	SXT=32 KHz	–	16	–	
			SRC=24 KHz	–	15	–	
		Slow, V <sub>CC</sub> =3V MODE3V=1 PWRSV=0	SXT=32 KHz	–	47	–	
			SRC=24 KHz	–	45	–	
		Idle, V <sub>CC</sub> =5V MODE3V=0	SXT=32 KHz	–	180	–	
			SRC=24 KHz	–	175	–	
		Idle, V <sub>CC</sub> =3V MODE3V=0	SXT=32 KHz	–	148	–	
			SRC=24 KHz	–	147	–	
		Idle, V <sub>CC</sub> =3V MODE3V=1 PWRSV=1	SXT=32 KHz	–	8	–	
			SRC=24 KHz	–	6	–	
		Idle, V <sub>CC</sub> =3V MODE3V=1 PWRSV=0	SXT=32 KHz	–	40	–	
SRC=24 KHz	–		38	–			
Stop, V <sub>CC</sub> =5V MODE3V=0	PWRSV=1	–	5	–			
	PWRSV=0	–	170	–			
Stop, V <sub>CC</sub> =3V MODE3V=0	PWRSV=1	–	3	–			
	PWRSV=0	–	145	–			
Stop, V <sub>CC</sub> =3V MODE3V=1	PWRSV=1	–	3	–			
	PWRSV=0	–	36	–			

Parameter	Symbol	Conditions	Min.	Typ.	Max.	Unit	
System Clock Frequency	F <sub>SYSCLK</sub>	V <sub>CC</sub> >LVR <sub>th</sub>	V <sub>CC</sub> =2.9V	–	–	8	MHz
			V <sub>CC</sub> =2.3V	–	–	7.3728	
			V <sub>CC</sub> =2.0V	–	–	4	
LVR Reference Voltage	V <sub>LVR</sub>	T <sub>A</sub> =25°C	F5264B/68B	-3%	2.9	+3%	V
			F5264C/68C	-3%	2.3	+3%	
			F5264B/68B	-8%	1.8	+8%	
			F5264C/68C	-8%	2.0	+8%	
LVR Hysteresis Voltage	V <sub>HYST</sub>	T <sub>A</sub> =25°C	–	±0.1	–	V	
LVD Reference Voltage	V <sub>LVD</sub>	T <sub>A</sub> =25°C	–	2.3	–	V	
Low Voltage Detection time	t <sub>LVR</sub>	T <sub>A</sub> =25°C	100	–	–	µs	
Pull-Up Resistor	R <sub>P</sub>	V <sub>IN</sub> =0V All except P3.7	V <sub>CC</sub> =5V	–	120	–	KΩ
			V <sub>CC</sub> =3V	–	220	–	
		V <sub>IN</sub> =0V P3.7	V <sub>CC</sub> =5V	–	170	–	
			V <sub>CC</sub> =3V	–	170	–	

### 3. Clock Timing (T<sub>A</sub>= -40°C ~ +85°C, V<sub>CC</sub>=3.0V~5.5V)

Parameter	Conditions	Min.	Typ.	Max.	Unit
Internal RC Frequency	25°C, V <sub>CC</sub> =3.0 ~ 5.5V	-1.6%	7.3728	+1.6%	MHz
	0°C ~ 70°C, V <sub>CC</sub> =3.0 ~ 5.5V	-3.8%	7.3728	+3.0%	
	-40°C ~ 85°C, V <sub>CC</sub> =3.0 ~ 5.5V	-8.0%	7.3728	+3.0%	

### 4. Reset Timing Characteristics (T<sub>A</sub>= -40°C ~ +85°C, V<sub>CC</sub>=3.0V~5.0V)

Parameter	Conditions	Min.	Typ.	Max.	Unit
RESET Input Low width	Input V <sub>CC</sub> =5.0V ±10%	90	–	–	µs
WDT wakeup time	V <sub>CC</sub> =5.0V, WDT <sub>PSC</sub> =11	–	40	–	ms
	V <sub>CC</sub> =3.0V, WDT <sub>PSC</sub> =11	–	40	–	

### 5. ADC Electrical Characteristics (T<sub>A</sub>=25°C, V<sub>CC</sub>=3.0V~5.5V, V<sub>SS</sub>=0V)

Parameter	Conditions	Min.	Typ.	Max.	Unit
Total Accuracy	V <sub>CC</sub> =5.12V, V <sub>SS</sub> =0V	–	±2.5	±4	LSB
Integral Non-Linearity		–	±3.2	±5	
Max Input Clock (f <sub>ADC</sub> )	–	–	–	1	MHz
Conversion Time	f <sub>ADC</sub> =1MHz	–	50	–	µs
BandGap Voltage Reference	V <sub>CC</sub> =3V	1.14	1.22	1.30	V
	V <sub>CC</sub> =5V	1.15	1.25	1.35	
Input Voltage	–	V <sub>SS</sub>	–	V <sub>CC</sub>	V

**Note:** also refer to AP-TM52XXXXX\_05S for using ADC to trim BandGap.



### 6. Characteristics Graphs

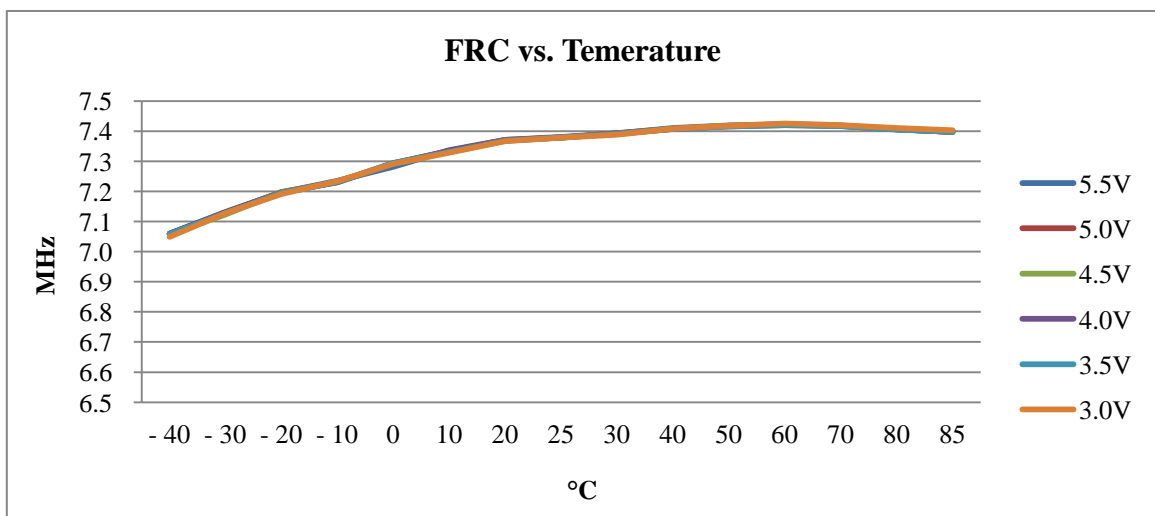
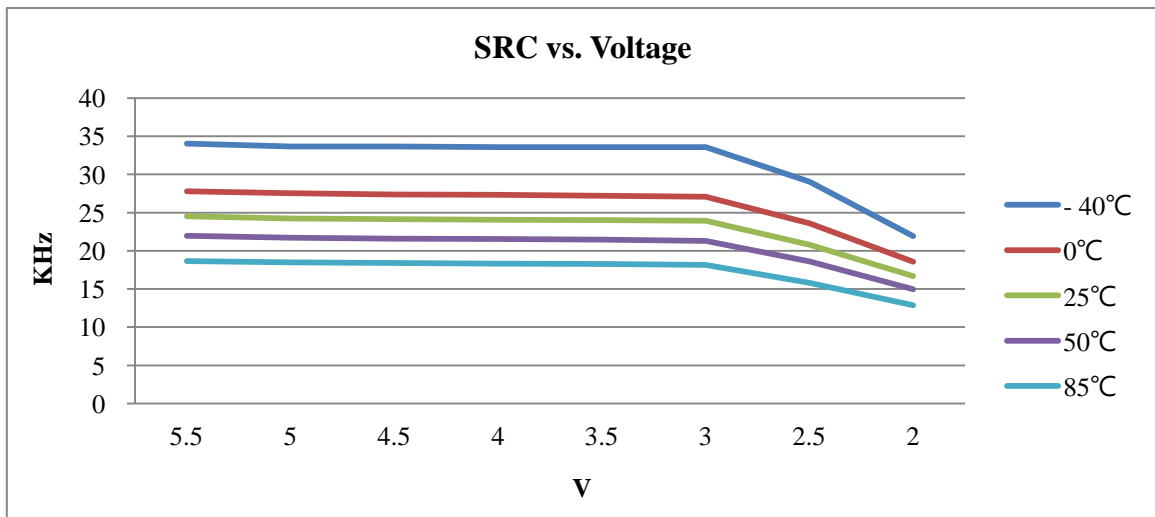
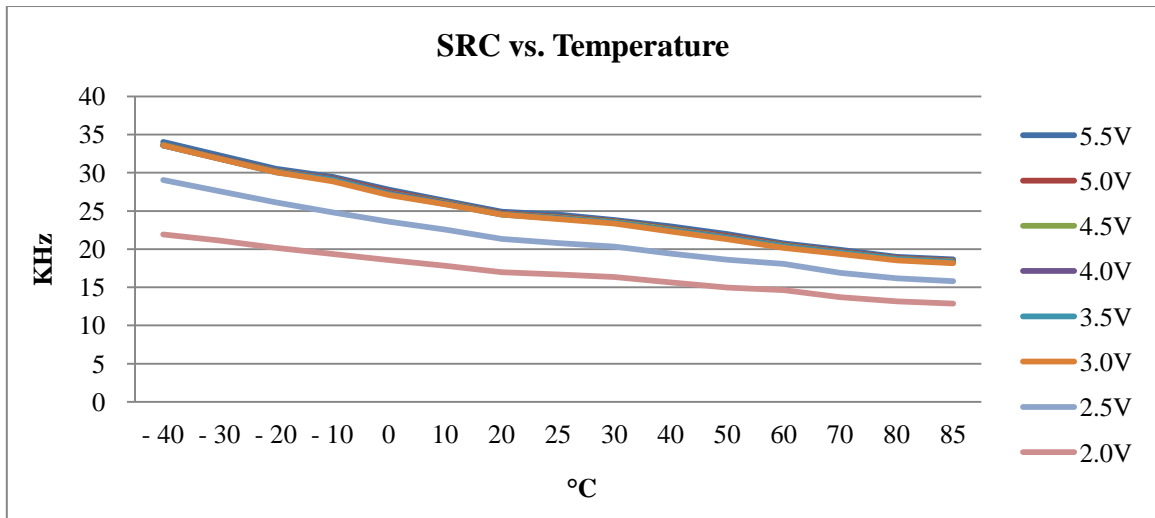

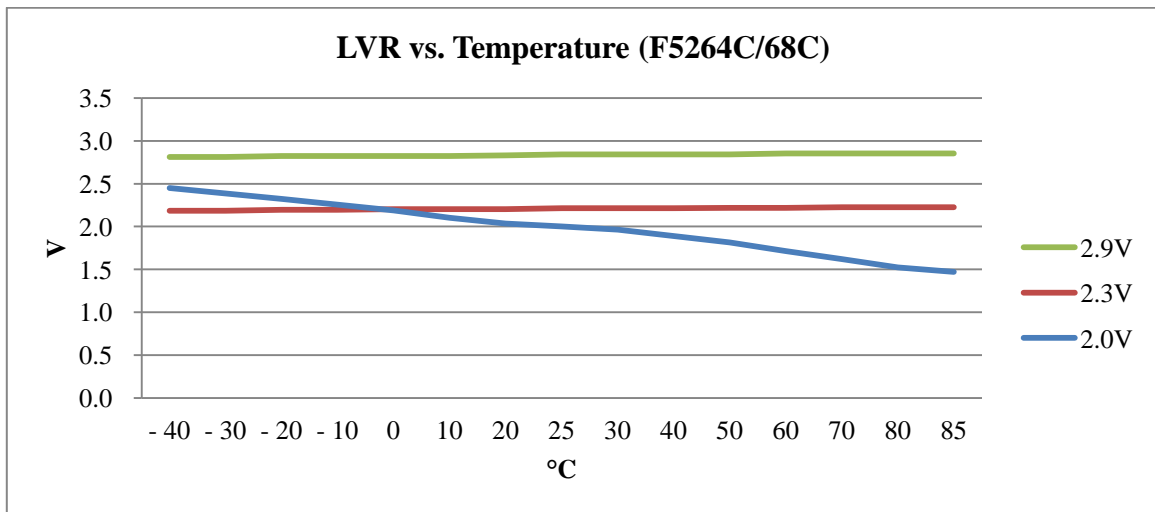
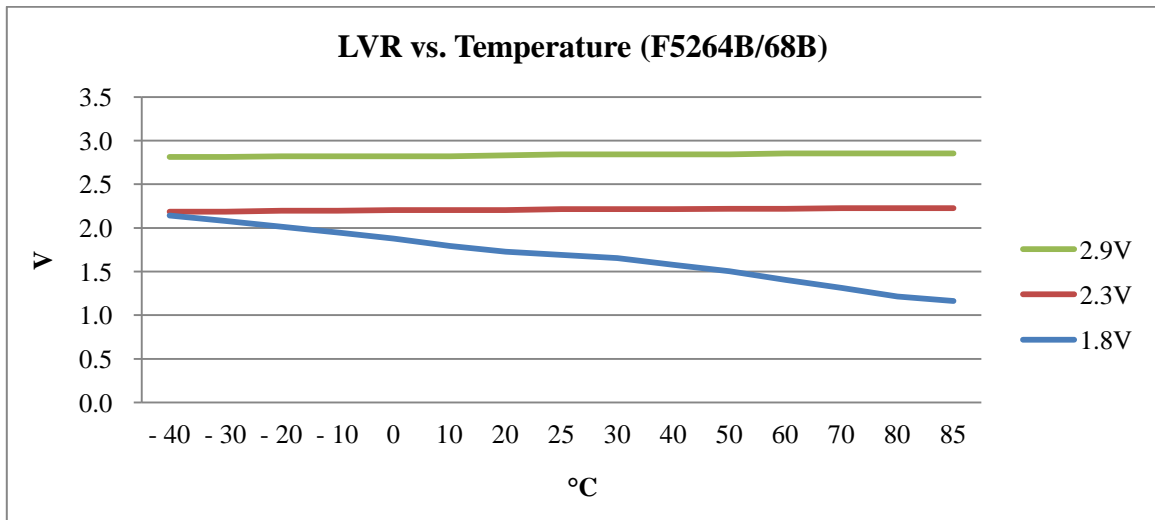
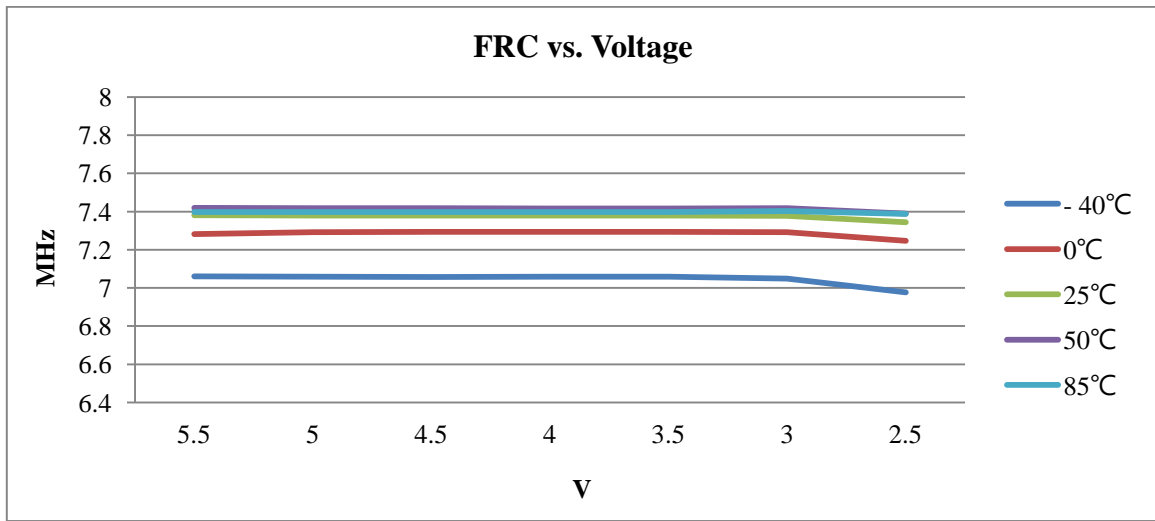

**Note:** Due to the variation of manufacturing process, this LVR will slightly vary between different chips.

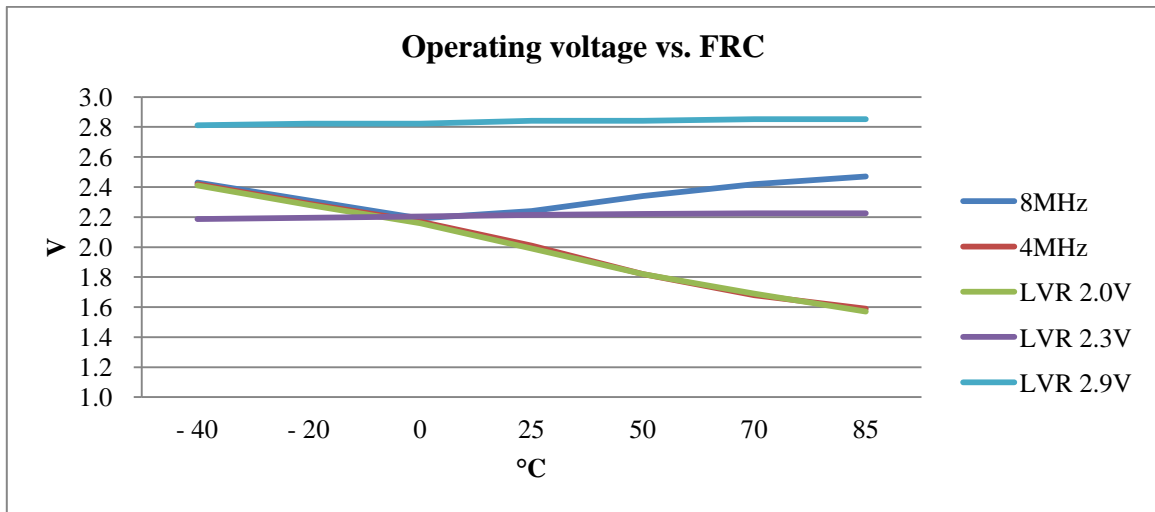

## PACKAGE INFORMATION

### Ordering Information

Ordering Number	Package
TM52F5264B-MTP	Wafer/Dice blank chip
TM52F5264B -COD	Wafer/Dice with code
TM52F5264B -MTP-05	DIP 20-pin (300 mil)
TM52F5264B -MTP-21	SOP 20-pin (300 mil)
TM52F5264B -MTP-22	SOP 24-pin (300 mil)
TM52F5264B -MTP-31	SSOP 20-pin (209 mil)
TM52F5264B -MTP-32	SSOP 24-pin (209 mil)
TM52F5268B -MTP	Wafer/Dice blank chip
TM52F5268B -COD	Wafer/Dice with code
TM52F5268B -MTP-05	DIP 20-pin (300 mil)
TM52F5268B -MTP-21	SOP 20-pin (300 mil)
TM52F5268B -MTP-22	SOP 24-pin (300 mil)
TM52F5268B -MTP-31	SSOP 20-pin (209 mil)
TM52F5268B -MTP-32	SSOP 24-pin (209 mil)
TM52F5264C-MTP	Wafer/Dice blank chip
TM52F5264C -COD	Wafer/Dice with code
TM52F5264C -MTP-05	DIP 20-pin (300 mil)
TM52F5264C -MTP-21	SOP 20-pin (300 mil)
TM52F5264C -MTP-22	SOP 24-pin (300 mil)
TM52F5264C -MTP-31	SSOP 20-pin (209 mil)
TM52F5264C -MTP-32	SSOP 24-pin (209 mil)
TM52F5268C -MTP	Wafer/Dice blank chip
TM52F5268C -COD	Wafer/Dice with code
TM52F5268C -MTP-05	DIP 20-pin (300 mil)
TM52F5268C -MTP-21	SOP 20-pin (300 mil)
TM52F5268C -MTP-22	SOP 24-pin (300 mil)
TM52F5268C -MTP-31	SSOP 20-pin (209 mil)
TM52F5268C -MTP-32	SSOP 24-pin (209 mil)

Package Information

DIP-20 ( 300mil ) Package Dimension

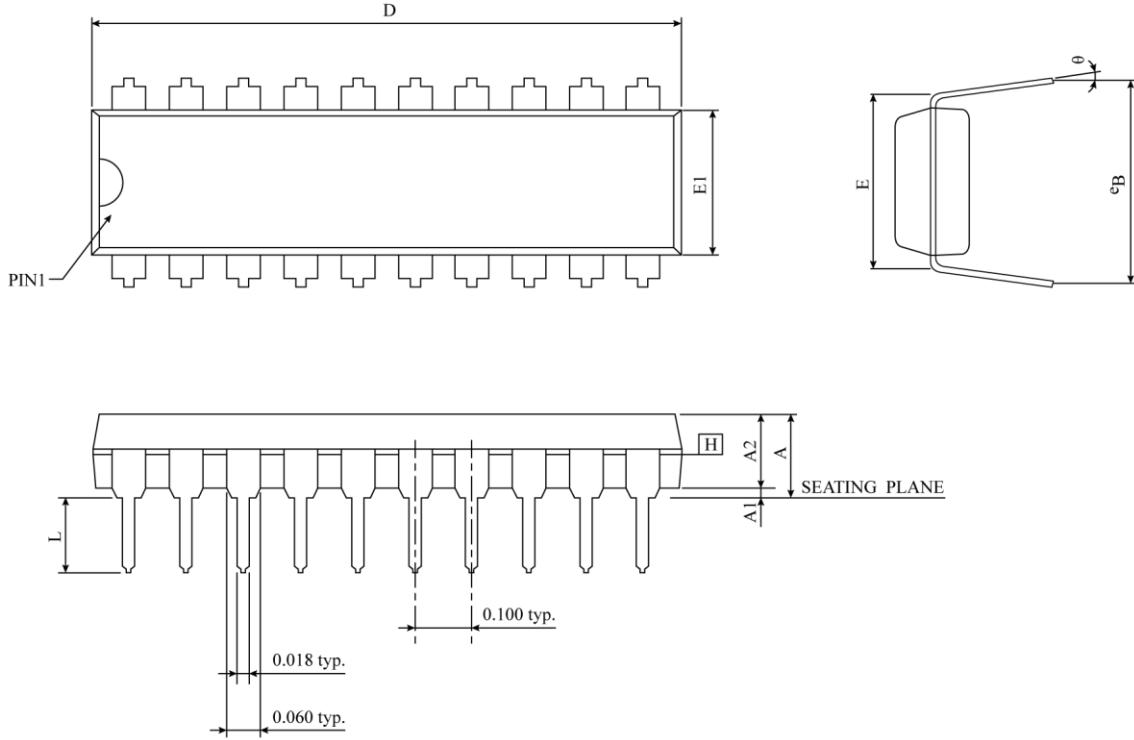

SYMBOL	DIMENSION IN MM			DIMENSION IN INCH		
	MIN	NOM	MAX	MIN	NOM	MAX
A	-	-	4.445	-	-	0.175
A1	0.381	-	-	0.015	-	-
A2	3.175	3.302	3.429	0.125	0.130	0.135
D	25.705	26.061	26.416	1.012	1.026	1.040
E	7.620	7.747	7.874	0.300	0.305	0.310
E1	6.223	6.350	6.477	0.245	0.250	0.255
L	3.048	3.302	3.556	0.120	0.130	0.140
eB	8.509	9.017	9.525	0.335	0.355	0.375
θ	0°	7.5°	15°	0°	7.5°	15°
JEDEC	MS-001 (AD)					

NOTES :

1. "D" , "E1" DIMENSIONS DO NOT INCLUDE MOLD FLASH OR PROTRUSIONS. MOLD FLASH OR PROTRUSIONS SHALL NOT EXCEED .010 INCH.
2. eB IS MEASURED AT THE LEAD TIPS WITH THE LEADS UNCONSTRAINED.
3. POINTED OR ROUNDED LEAD TIPS ARE PREFERRED TO EASE INSERTION.
4. DISTANCE BETWEEN LEADS INCLUDING DAM BAR PROTRUSIONS TO BE .005 INCH MINIMUM.
5. DATUM PLANE  $\square$  COINCIDENT WITH THE BOTTOM OF LEAD, WHERE LEAD EXITS BODY.

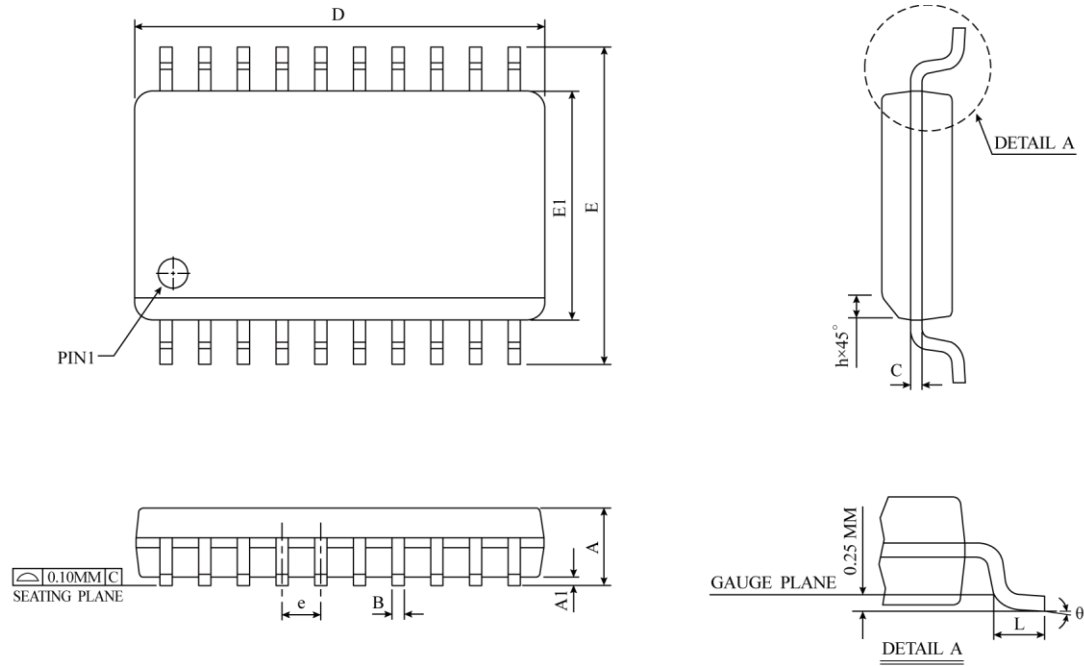
**SOP-20 ( 300mil ) Package Dimension**

SYMBOL	DIMENSION IN MM			DIMENSION IN INCH		
	MIN	NOM	MAX	MIN	NOM	MAX
A	2.35	2.50	2.65	0.0926	0.0985	0.1043
A1	0.10	0.20	0.30	0.0040	0.0079	0.0118
B	0.33	0.42	0.51	0.0130	0.0165	0.0200
C	0.23	0.28	0.32	0.0091	0.0108	0.0125
D	12.60	12.80	13.00	0.4961	0.5040	0.5118
E	10.00	10.33	10.65	0.3940	0.4425	0.4910
E1	7.40	7.50	7.60	0.2914	0.2953	0.2992
e	1.27 BSC			0.050 BSC		
h	0.25	0.50	0.75	0.0100	0.0195	0.0290
L	0.40	0.84	1.27	0.0160	0.0330	0.0500
θ	0°	4°	8°	0°	4°	8°
JEDEC	MS-013 (AC)					

▲ \* NOTES : DIMENSION "D" DOES NOT INCLUDE MOLD FLASH, PROTRUSIONS OR GATE BURRS.  
 MOLD FLASH, PROTRUSIONS AND GATE BURRS SHALL  
 NOT EXCEED 0.15 MM ( 0.006 INCH ) PER SIDE.

SOP 24-pin (300 mil) Package Dimensions

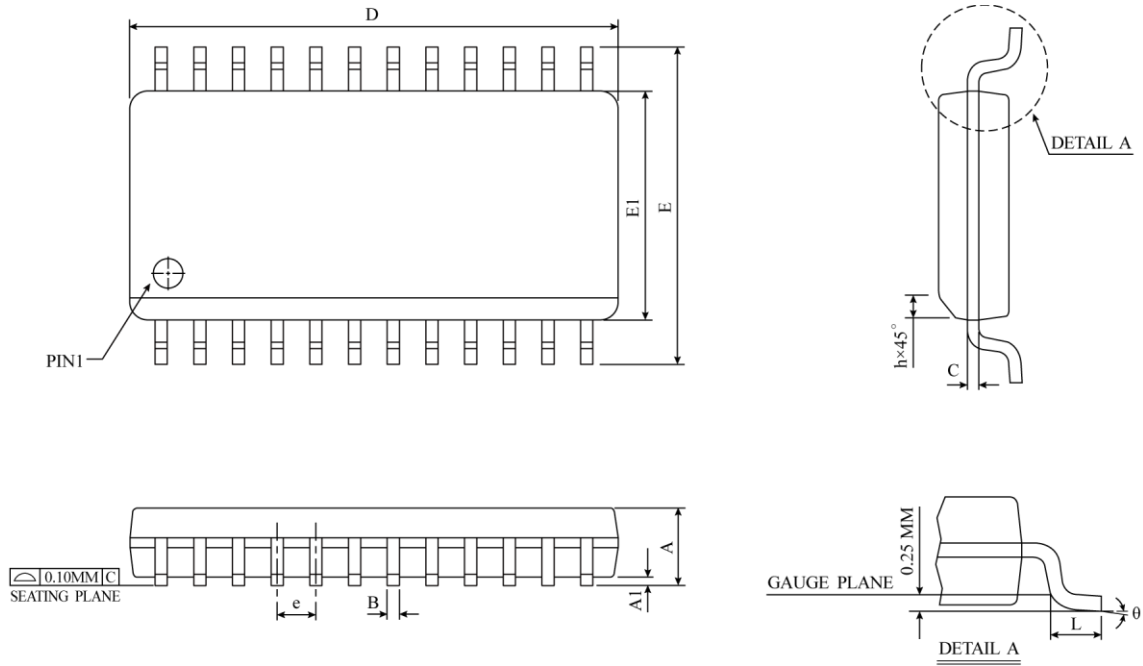

SYMBOL	DIMENSION IN MM			DIMENSION IN INCH		
	MIN	NOM	MAX	MIN	NOM	MAX
A	2.35	2.50	2.65	0.0926	0.0985	0.1043
A1	0.10	0.20	0.30	0.0040	0.0079	0.0118
B	0.33	0.42	0.51	0.0130	0.0165	0.0200
C	0.23	0.28	0.32	0.0091	0.0108	0.0125
D	15.20	15.40	15.60	0.5985	0.6063	0.6141
E	10.00	10.33	10.65	0.3940	0.4425	0.4910
E1	7.40	7.50	7.60	0.2914	0.2953	0.2992
e	1.27 BSC			0.050 BSC		
h	0.25	0.50	0.75	0.0100	0.0195	0.0290
L	0.40	0.84	1.27	0.0160	0.0330	0.0500
θ	0°	4°	8°	0°	4°	8°
JEDEC	MS-013 (AD)					

△ \* NOTES : DIMENSION "D" DOES NOT INCLUDE MOLD FLASH, PROTRUSIONS OR GATE BURRS.  
MOLD FLASH, PROTRUSIONS AND GATE BURRS SHALL NOT EXCEED 0.15 MM ( 0.006 INCH ) PER SIDE.

SSOP-20 ( 209mil ) Package Dimension

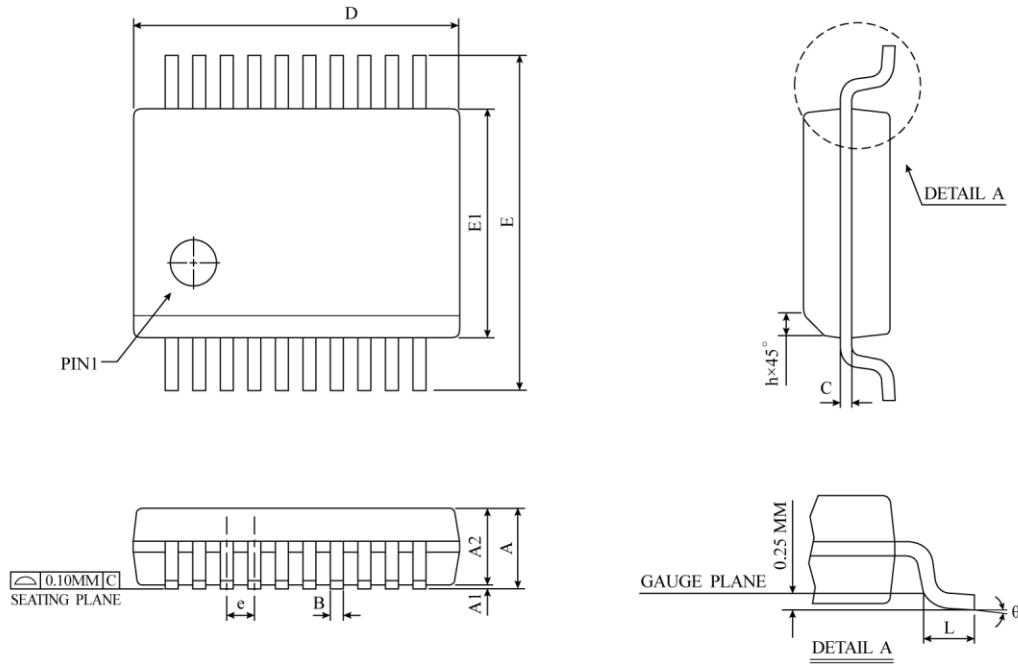

SYMBOL	DIMENSION IN MM			DIMENSION IN INCH		
	MIN	NOM	MAX	MIN	NOM	MAX
A	-	-	2.0	-	-	0.079
A1	0.05	-	-	0.002	-	-
A2	1.65	1.75	1.85	0.065	0.069	0.073
B	0.22	0.28	0.33	0.009	0.011	0.013
C	0.09	0.15	0.21	0.004	0.006	0.008
D	6.90	7.20	7.50	0.272	0.284	0.295
E	7.40	7.80	8.20	0.291	0.307	0.323
E1	5.00	5.30	5.60	0.197	0.209	0.220
e	0.65 BSC			0.026 BSC		
L	0.55	0.75	0.95	0.022	0.030	0.038
$\theta$	0°	4°	8°	0°	4°	8°
JEDEC	M0-150 (AE)					

△ \* NOTES : DIMENSION " D " DO NOT INCLUDE MOLD FLASH OR PROTRUSIONS,  
 BUT DO INCLUDE MOLD MISMATCH MOLD FLASH OR PROTRUSION SHALL NOT EXCEED  
 0.20 MM ( 0.008 INCH ) PER SIDE.

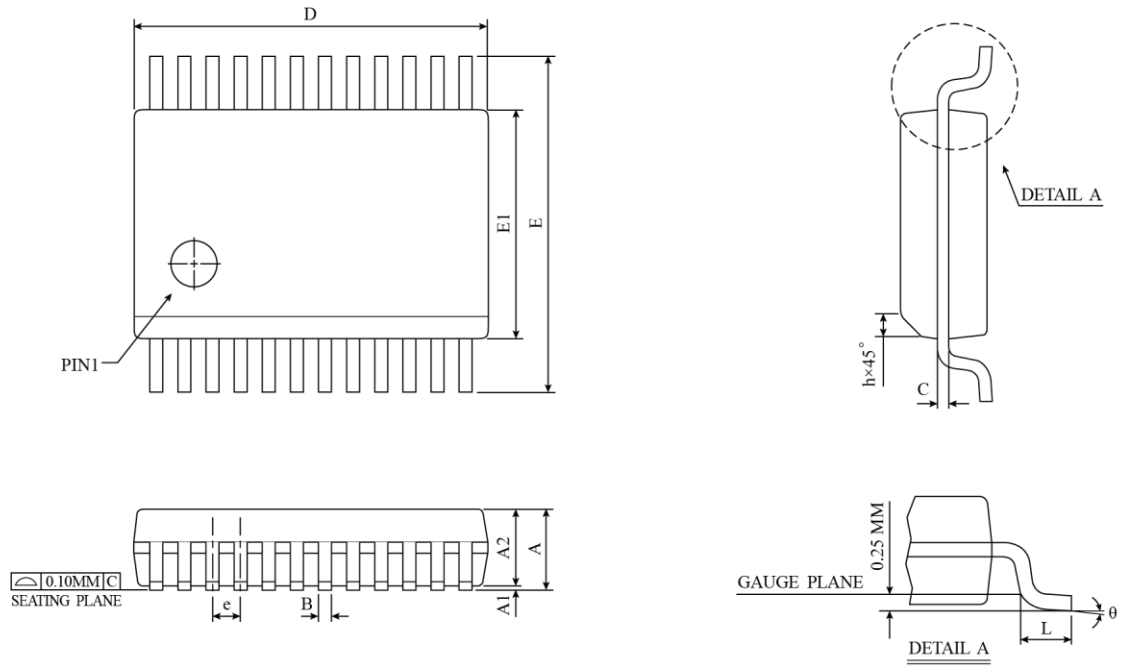

**SSOP-24 ( 209mil ) Package Dimension**

SYMBOL	DIMENSION IN MM			DIMENSION IN INCH		
	MIN	NOM	MAX	MIN	NOM	MAX
A	-	-	2.0	-	-	0.079
A1	0.05	-	-	0.002	-	-
A2	1.65	1.75	1.85	0.065	0.069	0.073
B	0.22	0.30	0.33	0.009	0.012	0.013
C	0.09	0.15	0.21	0.004	0.006	0.008
D	7.90	8.20	8.50	0.311	0.323	0.335
E	7.40	7.80	8.20	0.291	0.307	0.323
E1	5.00	5.30	5.60	0.197	0.209	0.220
e	0.65 BSC			0.026 BSC		
L	0.55	0.75	0.95	0.022	0.030	0.038
θ	0°	4°	8°	0°	4°	8°
JEDEC	M0-150 (AG)					

▲ \*NOTES : DIMENSION "D" DOES NOT INCLUDE MOLD FLASH OR PROTRUSIONS, BUT DO INCLUDE MOLD MISMATCH. MOLD FLASH OR SHALL NOT EXCEED 0.20 MM (0.078 INCH) PER SIDE.