

Active high precision signal conditioning module with millivolt level positive and negative signal for input and output

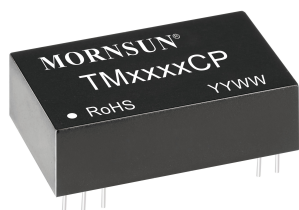

FEATURES

- Signal input, signal output, power input, and isolation power output are all isolated from each other
- High accuracy of 0.1% Full Scale
- High linearity of 0.1% Full Scale
- Isolation test voltage of 2.5kVDC for 60 seconds
- Extremely low temperature coefficient of 35PPM/°C
- Operating ambient temperature range -25°C to +71°C
- High reliability with >500,000 hours MTBF

The TMxxxxCP series are highly integrated and efficiency active signal conditioning modules, consisting of millivolt level positive and negative signal input with a positive and negative signal output. These modules have a built-in highly efficient and isolated micro-power source, that can provide energy for the integrated signal processing circuit as well as providing isolated power for peripheral devices and circuits. The product greatly simplifies the design of three-wire and four-wire user applications and also greatly reduces the space needed for circuitry on the PC Board. These modules have three-port isolation (input, output and power supply). These modules adopt unique electromagnetic isolation technology, allowing for higher accuracy and extremely low temperature drift in comparison with opto-coupler devices.

Selection Guide

| Part No. | Power Supply Input Typ. (VDC) | Input Signal | Output Signal | Isolation Power Output (VDC) |
|----------|-------------------------------|--------------|---------------|------------------------------|
| TM1630CP | 24V | ±10mV | ±5V | None |
| TM2630CP | 24V | ±20mV | ±5V | None |
| TM4630CP | 24V | ±50mV | ±5V | None |
| TM5630CP | 24V | ±75mV | ±5V | None |
| TM6630CP | 24V | ±100mV | ±5V | None |
| TM7650CP | 12V | ±200mV | ±5V | None |
| TM4530CP | 24V | ±50mV | ±10V | None |
| TM5530CP | 24V | ±75mV | ±10V | None |
| TM6530CP | 24V | ±100mV | ±10V | None |

Notes: Customization of products is available on request, for example:
 Power supply: 24/15/12VDC;
 Input signal: 0 to ±10/±20/±30/±50/±75/±100mV;
 Output signal: 0 to ±5V/±10V.

Input Specifications

| Item | Operating Conditions | | Value |
|--------------|-------------------------|---|-----------------------------------|
| Power Supply | Input voltage | | Typ. ±5% |
| | Input power | Isolated signal power at full load | ≤1W |
| | Power supply protection | | Input reverse polarity protection |
| Signal Input | Input signal | | See selection guide |
| | Input impedance | In case of max. input of voltage signal | ≥10MΩ |
| | Overload | | 10V |

Output Specifications

| Item | Operating Conditions | | Value |
|---------------|----------------------|--|---------------------|
| Signal Output | Output signal | | See selection guide |
| | Load capacity | In case of max. output of voltage signal | ≥2kΩ |

Transmission Specifications

| Item | Operating Conditions | Value |
|-------------------|---|--|
| Zero Offset | | -0.1%FS to 0.1%FS |
| Signal Precision | | -0.1%FS to 0.1%FS |
| Temperature Drift | Operating temperature range from -25°C to +71°C | 35PPM/°C (input signal range ≥100mV) 50PPM/°C (input signal range <100mV) |

General Specifications

| Item | Operating Conditions | Value |
|--|--|--|
| Electric Isolation | | signal input, signal output and power input terminals are all isolated from each other |
| Isolation Voltage | Electric Strength Test for 1 minute with a leakage current <1mA, humidity <70%RH | 2.5kVDC |
| Isolation Resistance | At 500VDC | 100MΩ |
| Operating Temperature | | -25°C to +71°C |
| Transportation and Storage Temperature | | -50°C to +105°C |
| Application Environment | | The presence of dust and corrosive gas may cause damage to the product |

Mechanical Specifications

| | |
|----------------|---|
| Case Material | Black plastic, flame-retardant and heat-resistant |
| Package | DIP24 |
| Weight | 11.4g(Typ.) |
| Cooling Method | Free air convection |

Electromagnetic Compatibility (EMC)

| | | | | |
|----------|-------|-----------------|--|------------------|
| Immunity | ESD | IEC/EN61000-4-2 | Contact ±4kV (see Fig. 2 for recommended circuit) | perf. Criteria B |
| | EFT | IEC/EN61000-4-4 | Power supply port ±2kV (see Fig. 2 for recommended circuit) | perf. Criteria B |
| | | IEC/EN61000-4-4 | Other ports ±1kV (see Fig. 2 for recommended circuit) | perf. Criteria B |
| | Surge | IEC/EN61000-4-5 | Power supply ±1kV (see Fig. 2 for recommended circuit) | perf. Criteria B |
| | | IEC/EN61000-4-5 | Other ports ±1kV (line to ground) (see Fig. 2 for recommended circuit) | perf. Criteria B |

Application Precautions

- Carefully read and follow the instructions before use; contact our technical support if you have any question;
- Do not use the product in hazardous areas;
- Use only DC power supply source for this product. 220VAC power supply is prohibited;
- It is strictly forbidden to disassemble the product privately in order to avoid product failure or malfunction.

After-sales service

- Factory inspection and quality control are strictly enforced before shipping any product; please contact your local representative or our technical support if you experience any abnormal operation or possible failure of the module;
- The products have a 3-year warranty period, from the date of shipment. The product will be repaired or exchanged free of charge within the warranty period for any quality problem that occurs under normal use.

Applied circuit

Please refer to Isolated Transmitter application notes.

Design Reference

1. Wiring diagram for product application & Schematic diagram

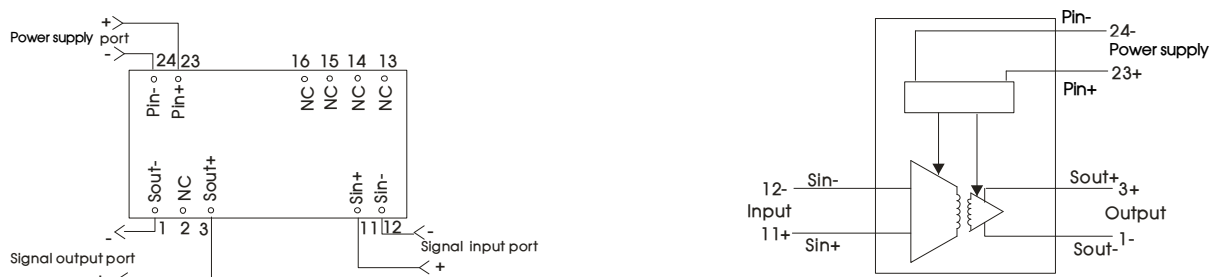

Fig.1

2. EMC compliance recommended circuit

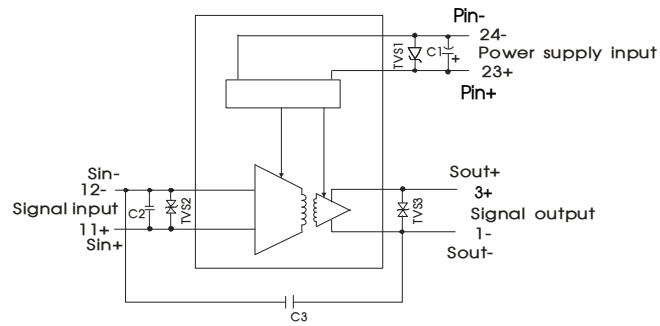

Fig.2

| Component | Recommended part |
|-----------|------------------|
| TVS1 | SMCJ30A |
| TVS2 | SMBJ5CA |
| TVS3 | SMBJ15CA |
| C1 | 220 μ F/35V |
| C2 | 1 μ F/50V |
| C3 | 2200pF/400VAC |

3. Schematic diagram of signal input and signal output(Ideal state)

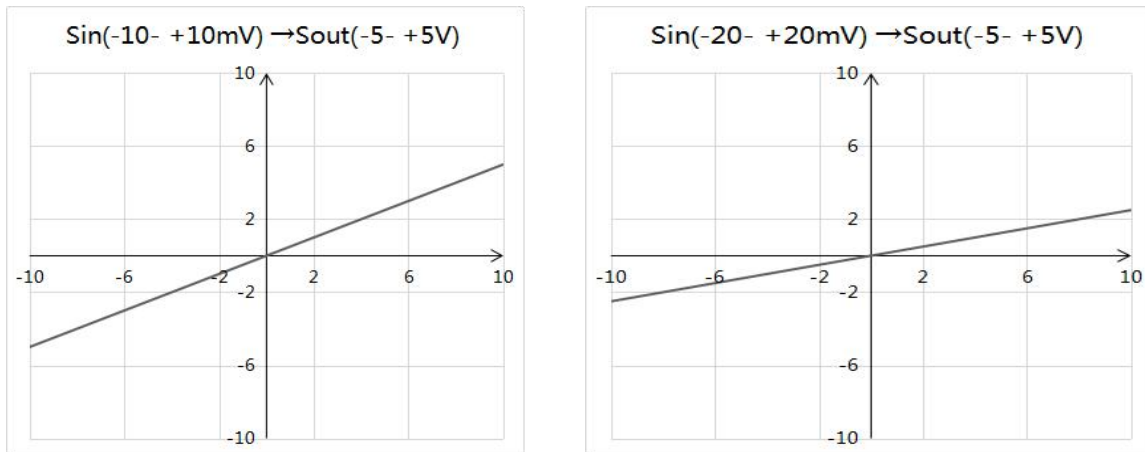
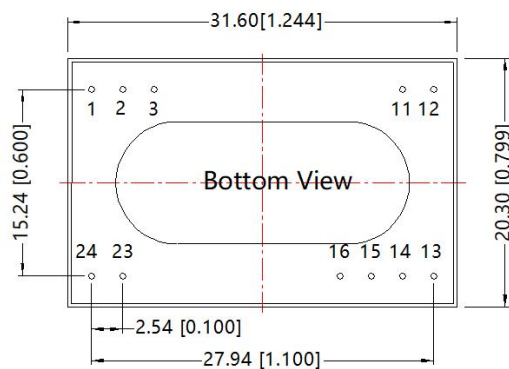
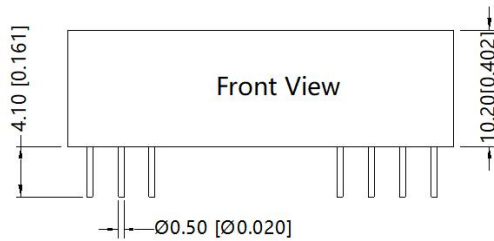

Fig. 3

4. For more information please find the application notes on www.mornsun-power.com

Dimensions and Recommended Layout

THIRD ANGLE PROJECTION 



Note:
Unit :mm[inch]
Pin diameter tolerances :±0.10[±0.004]
General tolerances:±0.50[±0.020]

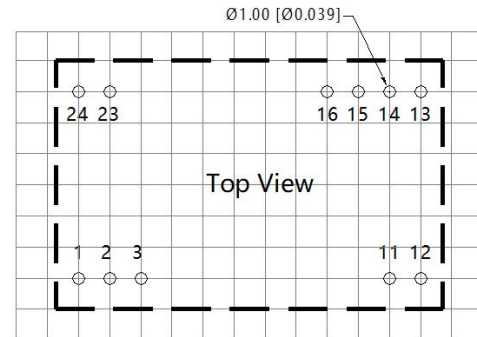

Note : Grid 2.54*2.54mm

| Pin-Out | | |
|---------|-------|------------------|
| Pin | Name | Function |
| 1 | Sout- | Signal output(-) |
| 2 | NC | No Connection |
| 3 | Sout+ | Signal output(+) |
| 11 | Sin+ | Signal input(+) |
| 12 | Sin- | Signal input(-) |
| 13 | NC | No Connection |
| 14 | NC | No Connection |
| 15 | NC | No Connection |
| 16 | NC | No Connection |
| 23 | Pin+ | Power supply(+) |
| 24 | Pin- | Power supply(-) |

NC:No connection

Notes:

- For additional information on Product Packaging please refer to www.mornsun-power.com. The Packaging bag number: 58210008;
- Unless otherwise specified, parameters in this datasheet were measured under the conditions of Ta=25°C, humidity<75%RH with nominal input voltage and rated output load;
- All index testing methods in this datasheet are based on company corporate standards;
- The above are the performance indicators of the product models listed in this datasheet. Some indicators of non-standard models will exceed the above requirements. For details, please contact our technical staff;
- We can provide product customization service, please contact our technicians directly for specific information;
- Products are related to laws and regulations: see "Features" and "EMC";
- Our products shall be classified according to ISO14001 and related environmental laws and regulations, and shall be handled by qualified units.

Mornsun Guangzhou Science & Technology Co., Ltd.

Address: No. 5, Kehui St. 1, Kehui Development Center, Science Ave., Guangzhou Science City, Huangpu District, Guangzhou, P. R. China
Tel: 86-20-38601850 Fax: 86-20-38601272 E-mail: info@mornsun.cn www.mornsun-power.com