



十速

# TM87ML28

*DATA SHEET*

*Rev V1.0*

**tenx** reserves the right to change or discontinue the manual and online documentation to this product herein to improve reliability, function or design without further notice. **tenx** does not assume any liability arising out of the application or use of any product or circuit described herein; neither does it convey any license under its patent rights nor the rights of others. **tenx** products are not designed, intended, or authorized for use in life support appliances, devices, or systems. If Buyer purchases or uses tenx products for any such unintended or unauthorized application, Buyer shall indemnify and hold tenx and its officers, employees, subsidiaries, affiliates and distributors harmless against all claims, cost, damages, and expenses, and reasonable attorney fees arising out of, directly or indirectly, any claim of personal injury or death associated with such unintended or unauthorized use even if such claim alleges that tenx was negligent regarding the design or manufacture of the part.

---

## AMENDMENT HISTORY

<b>Version</b>	<b>Date</b>	<b>Description</b>
1.0	Mar, 2018	New release.

# CONTENTS

<b>AMENDMENT HISTORY .....</b>	<b>2</b>
<b>GENERAL DESCRIPTION .....</b>	<b>4</b>
<b>FEATURE.....</b>	<b>4</b>
<b>APPLICATION.....</b>	<b>7</b>
<b>BLOCK DIAGRAM .....</b>	<b>7</b>
<b>PAD ASSIGNMENT.....</b>	<b>8</b>
<b>PIN DESCRIPTION.....</b>	<b>10</b>
<b>SERIAL PROGRAM/READ CONNECT PINS .....</b>	<b>12</b>
<b>ABSOLUTE MAXIMUM RATINGS .....</b>	<b>12</b>
<b>ALLOWABLE OPERATING CONDITIONS.....</b>	<b>13</b>
<b>ALLOWABLE OPERATING FREQUENCY .....</b>	<b>14</b>
<b>ELECTRICAL CHARACTERISTICS .....</b>	<b>15</b>
POWER CONSUMPTION .....	15
INTERNAL RC FREQUENCY RANGE .....	15
INPUT RESISTANCE.....	16
DC OUTPUT CHARACTERISTICS .....	17
SEGMENT DRIVER OUTPUT CHARACTERISTICS .....	18
REGULATOR & LOW-BATTERY-DETECT CIRCUIT CHARACTERISTICS .....	19
LOW-VOLTAGE-RESET CIRCUIT CHARACTERISTICS .....	21
TABLE ROM WORD WRITE BY INSTRUCTION OF PTR .....	21
TYPICAL APPLICATION CIRCUIT .....	22
<b>APPENDIX A TM87ML28 INSTRUCTION TABLE.....</b>	<b>23</b>
SYMBOL DESCRIPTION .....	36
<b>MWM/MMW RM ASSIGNMENT .....</b>	<b>37</b>

## GENERAL DESCRIPTION

The TM87ML28 is a Multiple Time Programmed ROM embedded high-performance 4-bit microcomputer with LCD driver. It contains all the necessary functions, such as 4-bit parallel processing ALU, ROM, RAM, I/O ports, timer, clock generator, dual clock operation, Resistance to Frequency Converter(RFC), EL panel driver, Serial Peripheral Interface (I2C/UART/SPI), LCD driver, look-up table, watchdog timer and key matrix scanning circuitry in a signal chip.

## FEATURE

### 1. Low power dissipation.

1.5V/3V operating voltage range.

TM87ML28L	1.5V Power Mode
TM87ML28H	3V Power Mode

### 2. Powerful instruction set.

Binary addition, subtraction, BCD. BCD can be executed directly in addition, subtraction.

4 bits x 4 bits Multiplier

Single-bit manipulation (set, reset, decision for branch).

Various conditional branches.

16 initial working registers and manipulators. (can be extended to all RAM by Page Mode)

Table look-up.

LCD driver data transfer.

- |   |    |            |
|---|----|------------|
| 3. ROM(MTP) capacity.   | 8K | x 16 bits. |
| ● Instruction ROM Max. capacity                                 | 8K | x 16 bits. |
| ● Table ROM Max. capacity                                       | 8K | x 8 bits.  |
| ● Endurance: 50000 cycles (min.)                                |    |            |
| ● Built-in Table ROM Word Write by Instruction in 3V Power Mode |    |            |

- |                  |      |          |
|------------------|------|----------|
| 4. RAM capacity. | 1024 | x 4bits. |
|------------------|------|----------|

### 5. With direct/index addressing mode in data RAM access.

### 6. LCD driver output.

- Max 423 LCD dots by 9 common outputs and 47 segment outputs.
- SEG24~47 can be defined as IOA1~4/CX,RFC0~2 , IOB1~4/ELC,ELP,BZB,BZ , IOC/KI1~4,IOD1~4,IOE1~4,IOF1~4 by option.
- 1/1~1/9 Duty can be selected by option.
- 1/2 ~1/3 Bias can be selected by option.
- Single instruction to turn off all segments.
- COM1~9,SEG1~47 can be defined as CMOS or P\_open drain type output by option.
- COM5~9 can be defined as SEG52~48 by option.
- Built-in regulator mode for VL1/2 by option.

#### 7. Input/output ports.

- Port IOA 4 pins (with internal pull-low, input signal chattering prevention circuitry), and can be defined as SEG24~27/ CX,RFC0~2 or CX,RFC0~2/ ELC,ELP,BZB,BZ /SDA,SCL,RXD,TXD by option.
- Port IOB 4 pins (with internal pull-low), and can be defined as SEG28~31/ ELC,ELP,BZB,BZ by option.
- Port IOC 4 pins (with internal pull-low, low-level-hold, input signal chattering prevention circuitry), and can be defined as SEG32~35 / KI1~4 by option.
- Port IOD 4 pins (with internal pull-low, input signal chattering prevention circuitry), and can be defined as SEG36~39 by option.
- Port IOE 4 pins (with internal pull-low, input signal chattering prevention circuitry), and can be defined as SEG40~43 or RFC3~5,CX2/ELC,ELP,BZB,BZ/SIOX,SIOY,SCK,SSB by option..
- Port IOF 4 pins (with internal pull-low, input signal chattering prevention circuitry), and can be defined as SEG44~47 by option.

#### 8. Interrupt function.

- External factors 6(INT pin, SIO, Port IOA, IOC, IOD & KI input).
- Internal factors 4(Pre-Divider, Timer1, Timer2, Timer3 & RFC).

#### 9. Built-in EL-light driver.

- ELC, ELP. Can be defined as SEG28,29/IOB1,2 or CX,RFC0/IOA1,2/SCA,SCL or RFC3,4/IOE1,2/MOSI,MISO by option.

#### 10. Built-in Alarm, clock or single tone melody generator.

- BZB, BZ. Can be defined as SEG30,31/IOB3,4 or RFC2,3/IOA3,4/RXD,TXD or RFC5,CX2/IOE3,4/SCK/SSB by option.

#### 11. Built-in resistance to frequency converter.

- CX,RFC0~2 Can be defined as SEG24~27/IOA1~4 or IOA1~4/ELC,ELP,BZB,BZ / SDA,SCL,RXD,TXD by option.
- RFC3~5,CX2 Can be defined as IOE1~4/ELC,ELP,BZB,BZ/SIOX,SIOY,SCK,SSB by option.

#### 12. Built-in key matrix scanning function.

- KO1~KO16(Shared with SEG1~16)
- KI1~KI4. Can be defined as SEG32~35/IOC1~4 by option.

#### 13. Built-in Serial Interface (UART/SPI/I2C).

- SDA,SCL,RXD,TXD Can be defined as CX,RFC0~2/IOA1~4/ELC,ELP,BZB,BZ by option.
- SIOX,SIOY,SCK,SSB Can be defined as RFC3~5,CX2/IOE1~4/ELC,ELP,BZB,BZ by option.

#### 14. Three 6-bit programmable timers with programmable clock source.

- Read out the content in anytime

15. Watch dog timer & Key-Reset (No initial LCD, CMOS, and P\_open drain type output data after reset by Watchdog timer or Key-Reset, and need select “OFF” for option of “LCD Display in Reset Cycle”.)
16. Built-in voltage charge halver & pump circuit.
17. Dual clock operation
  - slow clock oscillation can be defined as X’tal or external RC type oscillator by option.
  - fast clock oscillation can be defined as 3.58MHz ceramic resonator, internal R or external R type oscillator by option.
18. HALT function.
19. STOP function.
20. Built-in Low Battery Detect.
21. Built-in Low Voltage Reset.

## APPLICATION

- Timer / Calendar / Calculator / Thermometer

## BLOCK DIAGRAM

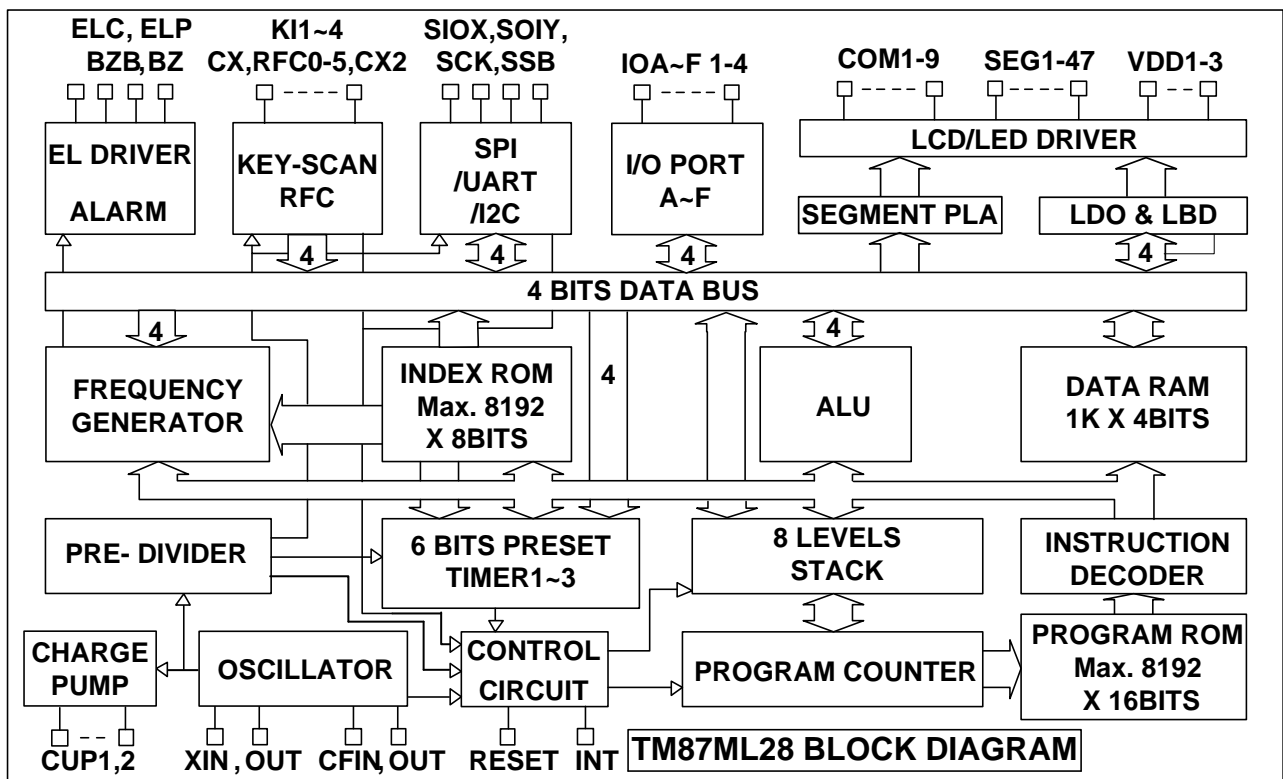

**PAD ASSIGNMENT**

No	Name	No	Name
1	BAK	41	SEG21
2	XIN	42	SEG22
3	XOUT	43	SEG23
4	CFIN	44	SEG24/IOA1/CX
5	CFOUT	45	SEG25/IOA2/RFC0<RR>
6	GND*	46	SEG26/IOA3/RFC1<RT>
7	VL1<VDD1>	47	SEG27/IOA4/RFC2<RH>
8	VL2<VDD2>	48	SEG28/IOB1/ELC
9	VL3<VDD3>	49	SEG29/IOB2/ELP
10	CUP1	50	SEG30/IOB3/BZB
11	CUP2	51	SEG31/IOB4/BZ
12	COM1	52	SEG32/IOC1/KI1
13	COM2	53	SEG33/IOC2/KI2
14	COM3	54	SEG34/IOC3/KI3
15	COM4	55	SEG35/IOC4/KI4
16	COM5/SEG52	56	SEG36/IOD1
17	COM6/SEG51	57	SEG37/IOD2
18	COM7/SEG50	58	SEG38/IOD3
19	COM8/SEG49	59	SEG39/IOD4
20	COM9/SEG48	60	SEG40/IOE1
21	SEG1(K1)	61	SEG41/IOE2
22	SEG2(K2)	62	SEG42/IOE3
23	SEG3(K3)	63	SEG43/IOE4
24	SEG4(K4)	64	SEG44/IOF1
25	SEG5(K5)	65	SEG45/IOF2
26	SEG6(K6)	66	SEG46/IOF3
27	SEG7(K7)	67	SEG47/IOF4
28	SEG8(K8)	68	CX'/IOA1'/ELC/SDA
29	SEG9(K9)	69	RFC0'/IOA2'/ELP/SCL
30	SEG10(K10)	70	RFC1'/IOA3'/BZB/RXD
31	SEG11(K11)	71	RFC2'/IOA4'/BZ/TXD
32	SEG12(K12)	72	RFC3'/IOE1'/ELC/SIOX(MISO/TXD/SDA)
33	SEG13(K13)	73	RFC4'/IOE2'/ELP/SIOY(MOSI/RXD/SCL)
34	SEG14(K14)	74	RFC5'/IOE3'/BZB/SCK
35	SEG15(K15)	75	CX2'/IOE4'/BZ/SSB
36	SEG16(K16)	76	RESET(VPP)
37	SEG17	77	INT
38	SEG18	78	VBAT
39	SEG19		
40	SEG20		

**Symbol Description**

'&lt;&gt;': Pin name in TM8726/27/67/68

'()': Attached function



'/' : Option function

'\*' : Two GND pad

'' : second group.

**PIN DESCRIPTION**

Name	I/O	Description
BAK	P	Positive Back-up voltage. If BAK=VL1/2 or VREG at BCF=0, connect a 0.1uF capacitor to GND. Positive voltage is need to BAK for Serial Program/Read Mode.
VBAT	P	Positive supply voltage. Positive voltage is need to VBAT for Serial Program/Read Mode.
VL1~3	P	LCD supply voltage. In 1.5V Power Mode & "LCD CHARGE PUMP MODE" option = "VL1(NO REGULATOR)", connect positive power output to VL1. In 3V Power mode & "LCD CHARGE PUMP MODE" option = "VL1(NO REGULATOR)" or "VL2(NO REGULATOR)", connect positive power to VL2. If "LCD CHARGE PUMP MODE" option = "VDL(1.05V)" or "VDL(2.10V)", connect Capacitors to VL1~3 For 1/3Bias by Capacitor Voltage Divider mode, connect positive power to VL3. Positive voltage is need to VL3 for Serial Program/Read Mode.
RESET	I	Input pin for external reset request signal, built-in internal pull-down resistor. High voltage is need to RESET pin for Serial Program/Read Mode.
INT	I	Input pin for external INT request signal. . Falling edge or rising edge triggered is defined by option. . Internal pull-down or pull-up resistor is defined by option.
CUP1,2	O	Switching pins for supply the LCD driving voltage to the VL1~3 pins. . Connect the CUP1 to CUP2 pins with non-polarized electrolytic capacitors when chip operated in 1/2 or 1/3 bias mode.
XIN XOUT	I O	Low speed oscillator, generates clock for time base functions(clock specified. LCD alternating frequency. Alarm signal frequency) or system clock oscillation. . The usage of 32KHz Crystal oscillator or external RC oscillator is defined by option.
CFIN CFOUT	I O	High speed oscillator, system clock oscillation for FAST clock only or DUAL clock operation. The usage of 3.58MHz ceramic/resonator oscillator or external R type oscillator is defined by option
COM1~9	O	Output pins for driving the common pins of the LCD panel. COM1~4 can be defined as COMS or Open Drain type output by option if COM5 is not defined as SEG52. COM5~9 can be defined as COMS or Open Drain type output or SEG52~48 by option.
SEG1-47	O	Output pins for driving the LCD panel segment. SEG24~27 can be defined as IOA1~4/CX,RFC0~2 by option. SEG28~31 can be defined as IOB1~4/ELC,ELP,BZB,BZ by option. SEG32~35 can be defined as IOC1~4/KI1~4 by option. SEG36~39 can be defined as IOD1~4 by option. SEG40~43 can be defined as IOE1~4 by option. SEG44~47 can be defined as IOF1~4 by option. SEG1~47 can be defined as COMS or Open Drain type output by option.
IOA1-4	I/O	Input / Output port A, and can be defined as SEG24~27/CX,RFC0~2 or CX,RFC0~2/ELC,ELP,BZB,BZ/SDA,SCL,RXD,TXD by option. Only one group of SEG24~27/CX,RFC0~2 and CX,RFC0~2/ELC,ELP,BZB,BZ/SDA,SCL,RXD,TXD can be defined as IOA1~ 4.
IOB1-4	I/O	Input / Output port B, and can be defined as SEG28~31/ELC,ELP,BZB,BZ by option.
IOC1-4	I/O	Input / Output port C, and can be defined as SEG32~35/KI1~4 by option. IOC3,4 is Signal for Serial Program/Read Mode.
IOD1~4	I/O	Input / Output port D, and can be defined as SEG36~39 by option.
IOE1~4	I/O	Input / Output port E, and can be defined as SEG40~43 or RFC3~5,CX2/ELC,ELP,BZB,BZ/MOSI/MISO/SCK/SSB by option. Only one group of SEG40~43 and RFC3~5,CX2/ELC/ELP,BZB,BZ/SIOX,SIOY,SCK, SSB

Name	I/O	Description
		can be defined as IOE1~4.
IOF1~4	I/O	Input / Output port F, and can be defined as SEG44~47 by option.
CX,CX2 RFC0~5	I O	2 input pin and 6 output pins for RFC application. CX,RFC0~2 can be defined as SEG24~27/IOA1~4 or IOA1~4/ELC,ELP,BZB,BZ/ SDA,SCL,RXD,TXD by option. RFC3~5,CX2 can be defined as IOE1~4/ELC,ELP,BZB,BZ/ SIOX,SIOY,SCK,SSB by option. Only one group of SEG24~27/IOA1~4 and IOA1~4 can be defined as CX,RFC0~2.
ELC/ELP	O	Output port for EL panel driver, and can be defined as SEG28,29/IOB1,2 or CX,RFC0/IOA1,2/SCA,SCL or RFC3,4/ IOE1,2/MOSI,MISO by option.
BZB/BZ	O	Output port for alarm, clock or single tone melody generator, and can be defined as SEG30,31 / IOB3,4 or RFC1,2/IOA3,4/RXD,TXD or RFC5,CX2/IOE3,4/SCK,SSB by option.
KO1~KO16	O	Output port for key matrix scanning, shared with SEG1~16.
KI1~4	I	Input port for key matrix scanning, and can be defined as SEG32~35/IOC1~4 by option.
SDA SCL	I/O O	1 input/output data pins, 1 output synchronous clock pin for I2C application, and can be defined as. CX,RFC0/IOA1,2/ELC,ELP by option.
RXD TXD	I I/O	1 input data pins, 1 input/output data pin for UART application, and can be defined as. RFC1,2/IOA3,4/BZB,BZ by option.
SIOX,SIOY, SCK,SSB	I/O	2 input/output data pins, 1 input/output synchronous clock pin, and 1 input/output slave select pin for SPI application, and can be defined as RFC3~5,CX2/IOE1~4/ELC,ELP, BZB,BZ by option. SIOX,SIOY can be set as SDA,SCL/RXD,TXD pins for UART/I2C by instructon if IOA 1,2/3,4 not set to SDA,SCL/RXD,TXD.
GND	P	Negative supply voltage.

**SERIAL PROGRAM/READ CONNECT PINS**

VBAT, GND, BAK, VL3, RESET, IOC3, IOC4

**ABSOLUTE MAXIMUM RATINGS**

GND= 0V

Name	Symbol	Range	Unit
Maximum Supply Voltage	VBAT	-0.3 to 3.6	V
	VL1	-0.3 to 2.1	
	VL2	-0.3 to 3.6	
	VL3	-0.3 to 6.0	
	VL4	-0.3 to 6.0	
	VL5	-0.3 to 6.0	
Maximum Input Voltage	Vin1	-0.3 to VBAT+0.3	
	Vin2	-0.3 to VL1/2+0.3	
Maximum output Voltage	Vout1	-0.3 to VBAT+0.3	
	Vout2	-0.3 to VL1/2+0.3	
	Vout3	-0.3 to VL3+0.3	
	Vout4	-0.3 to VL4+0.3	
	Vout5	-0.3 to VL5+0.3	
Maximum Operating Temperature	Topg	-40 to +80	°C
Maximum Storage Temperature	Tstg	-40 to +125	

## ALLOWABLE OPERATING CONDITIONS

at#1: 1.5V Power Mode Ta=-20°C to 70°C,GND= 0V

at#2: 3V Power Mode(BCF=0 : BAK < VBAT) , Ta=-20°C to 70°C,GND= 0V

at#3: 3V Power Mode(BCF=0 : BAK=VBAT) , Ta=-40°C to 80°C,GND= 0V

Crystal Mode condition : XIN&XOUT without match capacitor

Name	Symb.	Condition	Min.	Max.	Unit	
Supply LCD Voltage	VL1		0.95	1.8	V	
	VL2		1.8	3.6		
	VL3		1.8	5.4		
Oscillator Start-Up Voltage	BAK	Crystal Mode BCF=1 , #1	1.4			
		Crystal Mode BCF=1 , #2	1.5			
		Crystal Mode BCF=1 , #3	1.6			
Oscillator Sustain Voltage	BAK	Crystal Mode BCF=0 , #1	1.1	1.8		
		Crystal Mode BCF=0 , #2	1.1	3.6		
		Crystal Mode BCF=0 , #3	1.3	3.6		
Supply Voltage	BAK		1.2 *1	3.6		
Supply Voltage	VBAT	1.5V Power Mode without regulator	1.2 *1	1.8		
		1.5V Power Mode with regulator	1.35 *1	1.8		
		3V Power Mode without regulator BAK=VBAT for BCF=0	1.8	3.6		
		3V Power Mode without regulator BAK=VL1 for BCF=0	2.4	3.6		
		3V Power Mode with regulator VL2=VDL	2.0	3.6		
		3V Power Mode with regulator VL1=VDL	1.8	3.6		
Input "H" Voltage	Vih1	I/O,INT,RESETB,CX	0.8xVBAT	VBAT		
Input "L" Voltage	Vil1		0	0.2xVBAT		
Input "H" Voltage	Vih2	OSCIN	0.8xBAK	BAK		
Input "L" Voltage	Vil2		0	0.2xBAK		
Operating Freq	Fpg1	Crystal Mode	32			
	Fpg2	RC Mode	10	4096		
	Fpg3	CF Mode	1000	4096		
Power-down stable time before Power-on reset activation	Tpds	Va= 0.1xVBAT	1			S
Power-on reset activation power rise time	Tpor	Va/Vb= 0.1/0.9 x VBAT VBAT>=1.2V		10		mS

\*1 : Crystal mode need take care Oscillator Start-Up Voltage.

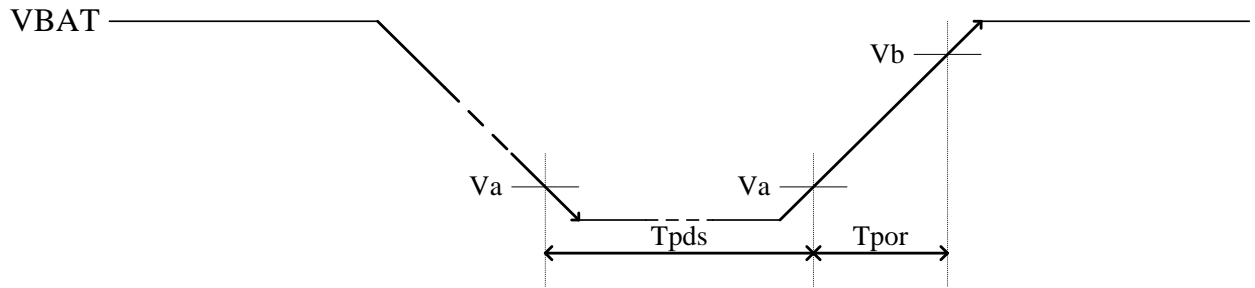

## ALLOWABLE OPERATING FREQUENCY

At #1 Ta= 0°C to 80°C,GND= 0V

At #2 Ta=-20°C to 80°C,GND= 0V

At #3 Ta=-40°C to 80°C,GND= 0V

Condition	Maximum Operating Frequency
BAK=1.2V #1	500KHz
BAK=1.3V #2	1MHz
BAK=1.4V #3	1.5MHz
BAK=1.8V #3	4MHz
BAK=2.2V #3	6MHz

## ELECTRICAL CHARACTERISTICS

### Power Consumption

at Ta=-40°C to 80°C, GND= 0V

Halt Condition : BCF=0 , 1/3Bias , 1/9Duty , LCD Alternating Frequency = PH6 , Charge Pump Cycle = PH5 ,  
Only 32.768KHz Crystal oscillator operating, without loading.

Name	Sym.	Condition	Min.	Typ.	Max.	Unit
HALT mode	IHALT1	1.5V Power Mode, VBAT=1.5V		5		uA
	IHALT2	3V Power Mode(BCF=0 => BAK=VL1), VBAT=3.0V, without regulator current		2		
	IHALT3	3V Power Mode(BCF=0 => BAK=VBAT), VBAT=3.0V, without regulator current		10		
STOP mode	ISTOP				1	
Regulator Current	I <sub>REG</sub>	3V Power Mode, VBAT=3.0V		1		
LVR Current	I <sub>lvr</sub>	VBAT=3.0V		0.2	0.5	

Note : When RC oscillator function is operating, the current consumption will depend on the frequency of oscillation.

### Internal RC Frequency Range

at #1 : Ta=0°C to 80°C, GND= 0V

at #2 : Ta=-20°C to 80°C, GND= 0V

at #3 : Ta=-40°C to 80°C, GND= 0V

Option Mode	BAK	Min.	Typ.	Max.
2MHz (No Temperature Compensation)	1.2V,#1	0.5MHz	1.2MHz	2.2MHz
	1.3V,#2	0.5MHz	1.5MHz	2.5MHz
	1.4V,#3	0.6MHz	1.6MHz	2.6MHz
	1.5V,#3	0.7MHz	1.7MHz	2.7MHz
	1.8V,#3	0.9MHz	1.9MHz	2.9MHz
	2.4V,#3	1.0MHz	2.0MHz	3.0MHz
	3.0V,#3	1.0MHz	2.05MHz	3.0MHz
4MHz (Temperature Compensation)	3.6V,#3	1.0MHz	2.1MHz	3.0MHz
	1.8V,#1	-2%	4.00MHz	+4%
	1.8V,#2	-4%	4.00MHz	+4%
	1.8V,#3	-8%	4.00MHz	+4%

**Input Resistance**

at#1:VBAT=1.5V(1.5V Power Mode)

at#2:VBAT=3.0V(3V Power Mode)

at Ta=-40°C to 80°C,GND= 0V

Name	Symb.	Condition	Min.	Typ.	Max.	Unit
“L” Level Hold Tr.(IOC)	Rllh1	Vi=0.2VBAT,#1	10	40	100	KΩ
	Rllh2	Vi=0.2VBAT,#2	10	40	100	
INT,IOA('),B,C,D,E('),SCK(Normal) Pull-Down Tr.	Rnpd1	Vi=VBAT,#1	200	500	1000	
	Rnpd2	Vi=VBAT,#2	200	500	1000	
INT/IOA'/IOE'/SIO(Normal) Pull-up Tr.	Rnpu1	Vi=VBAT,#1	50	200	1000	
	Rnpu2	Vi=VBAT,#2	50	350	1000	
IOA'/IOE'/SIO(Small) Pull-up Tr.	Rspu1	Vi=VBAT,#1	10	40	100	
SCK(Small) Pull-Down Tr.	Rspu2	Vi=VBAT,#2	10	40	100	
RES Pull-Up R	Rres1	Vi= VBAT,#1	10	40	100	
	Rres2	Vi= VBAT,#2	10	40	100	



**DC Output Characteristics**

at#1:VBAT=1.2V

at#2:VBAT=2.4V

at Ta=-40°C to 80°C,GND= 0V

Name	Symb.	Condition	Port	Min.	Typ.	Max.	Unit
Output "H" Voltage	Voh1a	Ioh=-100uA,#1	COM1~9&	1.0			V
	Voh2a	Ioh=-1mA,#2	SEG1~23,	2.0			
Output "L" Voltage	Vol1a	Iol=200uA,#1	28~47 (for DC/OD)			0.2	
	Vol2a	Iol=2mA,#2	IOB~D,F			0.4	
			IOE(share with SEG 40 ~43)				
Output "H" Voltage	Voh1b	Ioh=-200uA,#1	SEG24~27	1.0			
	Voh2b	Ioh=-3mA,#2	(for DC/ OD)	2.0			
Output "L" Voltage	Vol1b	Iol=400uA,#1				0.2	
	Vol2b	Iol=5mA,#2	IOE(share with RFC 3~5,CX2)			0.4	
			ELC,ELP ,BZB,BZ(s hare with SIO)				
			SCA,SCL, TXD,SIOX, SIOY,SCK, SSB				
Output "L" Voltage	Vol2c	Iol=40mA,#2	COM1~9 (for LED)			0.6	

**Segment Driver Output Characteristics**

at#1:VL1=1.2V  
 at#2:VL2=2.4V  
 at#3:VL1=1.05V  
 at#4:VL2=2.10V  
 at#5:VL3=2.4V

Name	Symb.	Condition	For	Min.	Typ.	Max.	Unit	
Static display Mode								
Output "H" Voltage	Voh12f	loh=-1uA,#1,#2	SEG-n	2.2			V	
	Voh34f	loh=-1uA,#3		1.90				
Output "L" Voltage	Vol12f	lol=1uA,#1,#2				0.2		
	Vol34f	lol=1uA,#3,#4				0.2		
Output "H" Voltage	Voh12g	loh=-10uA,#1,#2		COM-n	2.2			
	Voh34g	loh=-10uA,#3			1.90			
Output "L" Voltage	Vol12g	lol=10uA,#1,#2				0.2		
	Vol34g	lol=10uA,#3				0.2		
1/2 Bias display Mode								
Output "H" Voltage	Voh12f	loh=-1uA,#1,#2	SEG-n		2.2			V
	Voh34f	loh=-1uA,#3		1.90				
Output "L" Voltage	Vol12f	lol=1uA,#1,#2				0.2		
	Vol34f	lol=1uA,#3,#4				0.2		
Output "H" Voltage	Voh12g	loh=-10uA,#1,#2		COM-n	2.2			
	Voh34g	loh=-10uA,#3			1.90			
Output "M1" Voltage	Vom112g	lol/h=+/-10uA,#1,#2			1.0	1.4		
	Vom134g	lol/h=+/-10uA,#3			0.85	1.25		
Output "L" Voltage	Vol12g	lol=10uA,#1,#2				0.2		
	Vol34g	lol=10uA,#3				0.2		
1/3 Bias display Mode								
Output "H" Voltage	Voh12h	loh=-1uA,#1,#2	SEG-n	3.4			V	
	Voh34h	loh=-1uA,#3,#4		2.95				
	Voh5h	loh=-1uA,#5		2.2				
Output "M1" Voltage	Vom112h	lol/h=+/-1uA,#1,#2			1.0	1.4		
	Vom134h	lol/h=+/-1uA,#3,#4			0.85	1.25		
	Vom15h	lol/h=+/-1uA,#5			0.6	1.0		
Output "M2" Voltage	Vom212h	lol/h=+/-1uA,#1,#2			2.2	2.6		
	Vom234h	lol/h=+/-1uA,#3,#4			1.95	2.30		
	Vom25h	lol/h=+/-1uA,#5			1.4	1.8		
Output "L" Voltage	Vol12h	lol=1uA,#1,#2				0.2		
	Vol34h	lol=1uA,#3,#4				0.2		
	Vol5h	lol=1uA,#5				0.2		
Output "H" Voltage	Voh12i	loh=-10uA,#1,#2		COM-n	3.4			
	Voh34i	loh=-10uA,#3,#4			2.95			
	Voh5i	loh=-1uA,#5			2.2			
Output "M1" Voltage	Vom112i	lol/h=+/-10uA,#1,#2			1.0	1.4		
	Vom134i	lol/h=+/-10uA,#3,#4			0.85	1.25		
	Vom15i	lol/h=+/-10uA,#5			0.6	1.0		
Output "M2" Voltage	Vom212i	lol/h=+/-10uA,#1,#2			2.2	2.6		
	Vom234i	lol/h=+/-10uA,#3,#4			1.90	2.30		
	Vom25i	lol/h=+/-10uA,#5			1.4	1.8		
Output "L" Voltage	Vol12i	lol=10uA,#1,#2				0.2		
	Vol34i	lol=10uA,#3,#4				0.2		
	Vol5i	lol=10uA,#5				0.2		

**Regulator & Low-Battery-Detect Circuit Characteristics**

(VBAT=3.0V for Li-B GND=0V, fosc=32,768Hz, Ta=25°C)  
at Ta=-20°C to 70°C, GND= 0V

Name	Symb.	Condition	Min.	Typ.	Max.	Unit
VREG regulator output for BAK	VREG	VDX4~0 = 1F	-0.10	2.75	+0.10	V
		VDX4~0 = 1E				
		VDX4~0 = 1D				
		VDX4~0 = 1C				
		VDX4~0 = 1B				
		VDX4~0 = 1A				
		VDX4~0 = 19				
		VDX4~0 = 18				
		VDX4~0 = 17				
		VDX4~0 = 16				
		VDX4~0 = 15				
		VDX4~0 = 14				
		VDX4~0 = 13				
		VDX4~0 = 12				
		VDX4~0 = 11				
		VDX4~0 = 10*				
		VDX4~0 = 0F				
		VDX4~0 = 0E				
		VDX4~0 = 0D				
		VDX4~0 = 0C				
		VDX4~0 = 0B				
		VDX4~0 = 0A				
		VDX4~0 = 09				
		VDX4~0 = 08				
		VDX4~0 = 07				
		VDX4~0 = 06				
		VDX4~0 = 05				
		VDX4~0 = 04				
VDX4~0 = 03						
VDX4~0 = 02						
VDX4~0 = 01						
VDX4~0 = 00*						
VDL regulator output for VL2 or BAK & for 3V Power Mode only & initial = 2.10V	VDL	VDL3~0 = F	-0.10	2.55	+0.10	V
		VDL3~0 = E				
		VDL3~0 = D				
		VDL3~0 = C				
		VDL3~0 = B				
		VDL3~0 = A				
		VDL3~0 = 9				
		VDL3~0 = 8				
		VDL3~0 = 7				
		VDL3~0 = 6*				
		VDL3~0 = 5				
		VDL3~0 = 4				
		VDL3~0 = 3				
		VDL3~0 = 2				
		VDL3~0 = 1				
		VDL3~0 = 0				

VDL regulator output for VL1 & initial = 1.05V	VDL	VDL3~0 = F	-0.10	1.70	+0.10	V
		VDL3~0 = E		1.65		
		VDL3~0 = D		1.60		
		VDL3~0 = C		1.55		
		VDL3~0 = B		1.50		
		VDL3~0 = A		1.45		
		VDL3~0 = 9		1.40		
		VDL3~0 = 8		1.35		
		VDL3~0 = 7		1.30		
		VDL3~0 = 6		1.25		
		VDL3~0 = 5		1.20		
		VDL3~0 = 4		1.15		
		VDL3~0 = 3		1.10		
		VDL3~0 = 2*		1.05*		
		VDL3~0 = 1		1.00		
VDL3~0 = 0	0.95					
VREG Stable time, BAK with 0.1uF Capacitor	TREG				600	ms
LBD voltage For 3V Power Mode only & initial = 2.4V	VLBD	LBD3~0 = F	-0.10	2.75	+0.10	V
		LBD3~0 = E		2.70		
		LBD3~0 = D		2.65		
		LBD3~0 = C		2.60		
		LBD3~0 = B		2.55		
		LBD3~0 = A		2.50		
		LBD3~0 = 9		2.45		
		LBD3~0 = 8*		2.40*		
		LBD3~0 = 7		2.35		
		LBD3~0 = 6		2.30		
		LBD3~0 = 5		2.25		
		LBD3~0 = 4		2.20		
		LBD3~0 = 3		2.15		
		LBD3~0 = 2		2.10		
		LBD3~0 = 1		2.05		
LBD3~0 = 0	2.00					
LBD voltage For 1.5/3V Power Mode & initial = 1.35/1.95V(*1/*2)	VLBD	LBD3~0 = F	-0.10	2.10	+0.10	V
		LBD3~0 = E		2.05		
		LBD3~0 = D		2.00		
		LBD3~0 = C*2		1.95*2		
		LBD3~0 = B		1.90		
		LBD3~0 = A		1.85		
		LBD3~0 = 9		1.80		
		LBD3~0 = 8		1.75		
		LBD3~0 = 7		1.70		
		LBD3~0 = 6		1.65		
		LBD3~0 = 5		1.60		
		LBD3~0 = 4		1.55		
		LBD3~0 = 3		1.50		
		LBD3~0 = 2		1.45		
		LBD3~0 = 1		1.40		
LBD3~0 = 0*1	1.35*1					
LBD circuit response time	TLBD				100	us

**Low-Voltage-Reset Circuit Characteristics**

(VBAT=3.0V for Li-B GND=0V)  
at Ta=-40°C to 80°C, GND= 0V

Name	Symb.	Condition	Min.	Typ.	Max.	Unit
Reset Voltage	Vlvr		0.90	1.50	2.55	V

**Table ROM Word Write by Instruction of PTR**

at Ta=-20°C to 80°C, GND= 0V

Name	Sym.	Condition	Min.	Typ.	Max.	Unit
Write Voltage	BAK	BAK=VREG	2.1	2.2	2.3	V
Write Time	Tptr				50	ms

**TYPICAL APPLICATION CIRCUIT**

This application circuit is simply an example, and is not guaranteed to work.

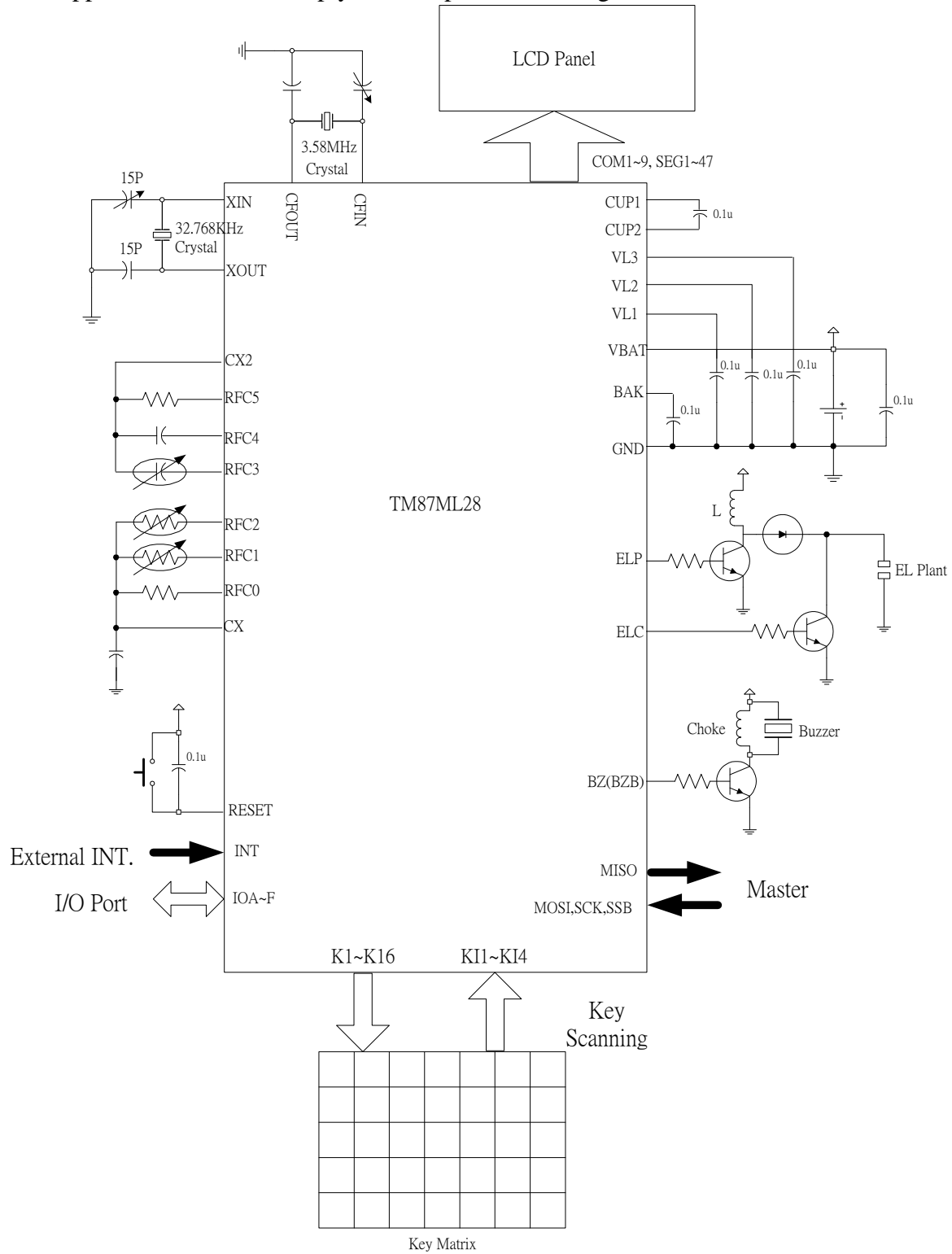

Regulator used for BAK & VL mode, 1/3 Bias, 1/9 Duty

**Appendix A TM87ML28 Instruction Table**

Instruction		Machine Code	Function		Flag/Remark
NOP		0000 0000 0000 0000	No Operation		
IDC&		0000 0001 0100 1010	HL	← HL+1	
LCT	Lz,Ry	0000 001Z ZZZZ YYYY	(Lz)	← (7SEG ← (Ry))	
LCB	Lz,Ry	0000 010Z ZZZZ YYYY	(Lz)	← (7SEG ← (Ry))	
LCP	Lz,Ry	0000 011Z ZZZZ YYYY	(Lz)	Blank Zero ← (Ry) & AC	
LCD LCD#	Lz,@HL	0000 100Z ZZZZ B000	(Lz) '#' : HL	← T(@HL) ← HL+1	' ' : B3=0 '#' : B3=1
LCT LCT#	Lz,@HL	0000 100Z ZZZZ B001	(Lz) "#" : HL	← (7SEG ← (@HL)) ← HL+1	' ' : B3=0 '#' : B3=1
LCB LCB#	Lz,@HL	0000 100Z ZZZZ B010	(Lz) '#' : HL	← (7SEG ← (@HL)) ← HL+1  Blank Zero	' ' : B3=0 '#' : B3=1
LCP LCP#	Lz,@HL	0000 100Z ZZZZ B011	(Lz) '#' : HL	← (@HL) & AC ← HL+1	' ' : B3=0 '#' : B3=1
LCDX	D	0000 1000 DD00 0100	Multi-Lz  D=00 D=01 D=10 D=11	← T@HL  : Multi-Lz=00H~0FH : Multi-Lz=10H~1FH : Multi-Lz=20H~2FH : Multi-Lz=30H~3FH	
LCTX	D	0000 1000 DD00 0101	Multi-Lz	← (7SEG ← @HL)	
LCBX	D	0000 1000 DD00 0110	Multi-Lz	← (7SEG ← @HL) Blank Zero	
LCPX	D	0000 1000 DD00 0111	Multi-Lz	← @HL & AC	
OPA	Rx	0000 1010 OXXX XXXX	Port(A)	← (Rx)	
OPAS	Rx,D	0000 1011 DXXX XXXX	A1,2,3,4	← (Rx)0,(Rx)1,D,Pulse	
OPB	Rx	0000 1100 OXXX XXXX	Port(B)	← (Rx)	
OPC	Rx	0000 1101 OXXX XXXX	Port(C)	← (Rx)	
OPD	Rx	0000 1110 OXXX XXXX	Port(D)	← (Rx)	
OPE	Rx	0000 1110 1XXX XXXX	Port(E)	← (Rx)	
FRQ	D,Rx	0001 00DD OXXX XXXX	FREQ D=00 D=01 D=10 D=11	← (Rx) & AC : 1/4 Duty : 1/3 Duty : 1/2 Duty : 1/1 Duty	
FRQ FRQ#	D,@HL	0001 01DD 0000 B000	FREQ '#' : HL	← T(@HL) ← HL+1	' ' : B3=0 '#' : B3=1
FRQX	D,X	0001 10DD XXXX XXXX	FREQ	← X	
MVL	Rx	0001 1100 OXXX XXXX	IDBF0~3	← (Rx)	
MVH	Rx	0001 1101 OXXX XXXX	IDBF4~7	← (Rx)	
MVU	Rx	0001 1110 OXXX XXXX	IDBF8~11	← (Rx)	
MVV	Rx	0001 1111 OXXX XXXX	IDBF12	← (Rx)0	
ADC ADC*	Rx	0010 000B OXXX XXXX	AC *' : (Rx)	← (Rx) + AC + CF ← AC	CF

ADC ADC# ADC* ADC*#	@HL	0010 000B 1B00 0000	AC '*' : (@HL) '#' : HL	← (@HL) + AC + CF ← AC ← HL+1	' ' : B8=0 '*' : B8=1  ' ' : B6=0 '#' : B6=1
ADC ADC# ADC* ADC*#	@HL,DA	0010 000B 1B01 0000	AC '*' : (@HL) '#' : HL	←BCD((@HL)+AC+CF) ← AC ← HL+1	
SBC SBC*	Rx	0010 001B 0XXX XXXX	AC '*' : (Rx)	← (Rx) + ACB + CF ← AC	CF  ' ' : B8=0 '*' : B8=1
SBC SBC# SBC* SBC*#	@HL	0010 001B 1B00 0000	AC '*' : (@HL) '#' : HL	← (@HL) + ACB + CF ← AC ← HL+1	' ' : B6=0 '#' : B6=1
SBC SBC# SBC* SBC*#	@HL,DA	0010 001B 1B01 0000	AC '*' : (@HL) '#' : HL	←BCD((@HL)+ACB+CF) ← AC ← HL+1	
ADD ADD*	Rx	0010 010B 0XXX XXXX	AC '*' : (Rx)	← (Rx) + AC ← AC	CF  ' ' : B8=0 '*' : B8=1
ADD ADD# ADD* ADD*#	@HL	0010 010B 1B00 0000	AC '*' : (@HL) '#' : HL	← (@HL) + AC ← AC ← HL+1	' ' : B6=0 '#' : B6=1
ADD ADD# ADD* ADD*#	@HL,DA	0010 010B 1B01 0000	AC '*' : (@HL) '#' : HL	←BCD((@HL)+AC) ← AC ←HL+1	
SUB SUB*	Rx	0010 011B 0XXX XXXX	AC '*' : (Rx)	← (Rx) + ACB + 1 ← AC	CF  ' ' : B8=0 '*' : B8=1
SUB SUB# SUB* SUB*#	@HL	0010 011B 1B00 0000	AC '*' : (@HL) '#' : HL	← (@HL) + ACB + 1 ← AC ← HL+1	' ' : B6=0 '#' : B6=1
SUB SUB# SUB* SUB*#	@HL,DA	0010 011B 1B01 0000	AC '*' : (@HL) '#' : HL	←BCD((@HL)+ACB+1) ← AC ← HL+1	
ADN ADN*	Rx	0010 100B 0XXX XXXX	AC '*' : (Rx)	← (Rx) + AC ← AC	' ' : B8=0 '*' : B8=1
ADN ADN# ADN* ADN*#	@HL	0010 100B 1B00 0000	AC '*' : (@HL) '#' : HL	← (@HL) + AC ← AC ←HL+1	' ' : B6=0 '#' : B6=1
AND	Rx	0010 101B 0XXX XXXX	AC	← (Rx) AND AC	' ' : B8=0



AND*			'*' : (Rx)	← AC	'*' : B8=1
AND AND# AND* AND*#	@HL	0010 101B 1B00 0000	AC '*' : (@HL) '#' : HL	← (@HL) AND AC ← AC ← HL+1	'*' : B6=0 '#' : B6=1
EOR EOR*	Rx	0010 110B 0XXX XXXX	AC '*' : (Rx)	← (Rx) EOR AC ← AC	'*' : B8=0 '*' : B8=1
EOR EOR# EOR* EOR*#	@HL	0010 110B 1B00 0000	AC '*' : (@HL) '#' : HL	← (@HL) EOR AC ← AC ← HL+1	'*' : B6=0 '#' : B6=1
OR OR*	Rx	0010 111B 0XXX XXXX	AC '*' : (Rx)	← (Rx) OR AC ← AC	'*' : B8=0 '*' : B8=1
OR OR# OR* OR*#	@HL	0010 111B 1B00 0000	AC '*' : (@HL) '#' : HL	← (@HL) OR AC ← AC ← HL+1	'*' : B6=0 '#' : B6=1
ADCI	Ry,D	0011 0000 DDDD YYYY	AC	← (Ry) + D + CF	CF
ADCI*	Ry,D	0011 0001 DDDD YYYY	AC,(Ry)	← (Ry) + D + CF	CF
SBCI	Ry,D	0011 0010 DDDD YYYY	AC	← (Ry) + DB + CF	CF
SBCI*	Ry,D	0011 0011 DDDD YYYY	AC,(Ry)	← (Ry) + DB + CF	CF
ADDI	Ry,D	0011 0100 DDDD YYYY	AC	← (Ry) + D	CF
ADDI*	Ry,D	0011 0101 DDDD YYYY	AC,(Ry)	← (Ry) + D	CF
SUBI	Ry,D	0011 0110 DDDD YYYY	AC	← (Ry) + DB + 1	CF
SUBI*	Ry,D	0011 0111 DDDD YYYY	AC,(Ry)	← (Ry) + DB + 1	CF
ADNI	Ry,D	0011 1000 DDDD YYYY	AC	← (Ry) + D	
ADNI*	Ry,D	0011 1001 DDDD YYYY	AC,(Ry)	← (Ry) + D	
ANDI	Ry,D	0011 1010 DDDD YYYY	AC	← (Ry) AND D	
ANDI*	Ry,D	0011 1011 DDDD YYYY	AC,(Ry)	← (Ry) AND D	
EORI	Ry,D	0011 1100 DDDD YYYY	AC	← (Ry) EOR D	
EORI*	Ry,D	0011 1101 DDDD YYYY	AC,(Ry)	← (Ry) EOR D	
ORI	Ry,D	0011 1110 DDDD YYYY	AC	← (Ry) OR D	
ORI*	Ry,D	0011 1111 DDDD YYYY	AC,(Ry)	← (Ry) OR D	
INC*	Rx	0100 0000 0XXX XXXX	AC,(Rx)	← (Rx) + 1	'*' : B6=0 '#' : B6=1
INC* INC*#	@HL	0100 0000 1B00 0000	AC,(@HL) '#' : HL	← (@HL) + 1 ← HL+1	CF
DEC*	Rx	0100 0001 0XXX XXXX	AC,(Rx)	← (Rx) - 1	'*' : B6=0 '#' : B6=1
DEC* DEC*#	@HL	0100 0001 1B00 0000	AC,(@HL) '#' : HL	← (@HL) - 1 ← HL+1	CF
MWM	Rm,Ry	0100 0100 MMMM YYYY	Rm	← Ry	
MMW	Ry,Rm	0100 0101 MMMM YYYY	AC,Ry	← Rm	
IPA	Rx	0100 0110 0XXX XXXX	AC,(Rx)	← Port(A)	
IPB	Rx	0100 0110 1XXX XXXX	AC,(Rx)	← Port(B)	
IPC	Rx	0100 0111 0XXX XXXX	AC,(Rx)	← Port(C)	
IPD	Rx	0100 1000 0XXX XXXX	AC,(Rx)	← Port(D)	

IPE	Rx	0100 1000 1XXX XXXX	AC,(Rx)	← Port(E)	
LDS LDS#	@HL,D	0100 1001 1B00 DDDD	AC, (@HL) #: HL	← D ← HL+1	‘ ‘ : B6=0 #: B6=1
MAF	Rx	0100 1010 0XXX XXXX	AC,(Rx)	← STS1	B3 : CF B2 : ZERO B1 : SCF12(CX2) *B B0 : SCF11(CX) *B
RTM2L	Rx	0100 1010 1XXX XXXX	AC,(Rx)	← TM2(0~3)	
MSB	Rx	0100 1011 0XXX XXXX	AC,(Rx)	← STS2	B3 : SCF3(DPT) B2 : SCF2(HRx) B1 : SCF1(CPT) B0 : BCF
RTM21	Rx	0100 1011 1XXX XXXX	AC,(Rx)	← TM2(4,5),1(0,1)	
MSC	Rx	0100 1100 0XXX XXXX	AC,(Rx)	← STS3	B3 : SCF7(PDV) B2 : PH15 B1 : SCF5(TM1) B0 : SCF4(INT/SIO)
RTM1H	Rx	0100 1100 1XXX XXXX	AC,(Rx)	← TM1(2~5)	
MCX	Rx	0100 1101 0XXX XXXX	AC,(Rx)	← STS3X	B3 : SCF9(RFC) *A B2 : SCF0(APT) B1 : SCF6(TM2) B0 : SCF8(SKI)
RTM3L	Rx	0100 1101 1XXX XXXX	AC,(Rx)	← TM3(0~3)	
MSD	Rx	0100 1110 0XXX XXXX	AC,(Rx)	← STS4	B3 : PGMF B2 : RFOVF B1 : WDF B0 : CSF
RTM31	Rx	0100 1110 1XXX XXXX	AC,(Rx)	← TM3(4,5), 1(0,1)	
MDX	Rx	0100 1111 0XXX XXXX	AC,(Rx)	← STS4X	B3 : SCF10(TM3) B2 : INT B1 : CX2 B0 : CX
MKI	Rx	0100 1111 1XXX XXXX	AC,Rx	← STS5(KI4~1)	
SR0	Rx	0101 0000 0XXX XXXX	ACn, (Rx)n AC3, (Rx)3	← (Rx)(n+1) ← 0	
SR1	Rx	0101 0000 1XXX XXXX	ACn, (Rx)n AC3, (Rx)3	← (Rx)(n+1) ← 1	
SL0	Rx	0101 0001 0XXX XXXX	ACn, (Rx)n AC0, (Rx)0	← (Rx)(n-1) ← 0	
SL1	Rx	0101 0001 1XXX XXXX	ACn, (Rx)n AC0, (Rx)0	← (Rx)(n-1) ← 1	
RRC RRC#	Rx @HL	0101 0010 0XXX XXXX 0101 0010 1B00 0000	ACn, (Rx)n AC3, (Rx)3 CF ACn, (@HL)n AC3,(@HL)3 CF #: HL	← (Rx)(n+1) ← CF ← (Rx)0 ← (@HL)(n+1) ← CF ← (@HL)0 ← HL+1	CF ‘ ‘ : B6=0 #: B6=1
RLC	Rx	0101 0011 0XXX XXXX	ACn, (Rx)n AC0, (Rx)0 CF	← (Rx)(n-1) ← CF ← (Rx)3	CF ‘ ‘ : B6=0 #: B6=1

RLC RLC#	@HL	0101 0011 1B00 0000	ACn, (@HL)n AC0, (@HL)0 CF #: HL	← (@HL)(n-1) ← CF ← (@HL)3 ← HL+1	
DAA		0101 0100 0000 0000	AC	← BCD(CF,AC) for add.	CF
DAA*	Rx	0101 0101 0XXX XXXX	AC,(Rx)	← BCD(CF,AC) for add.	' ': B6=0 #: B6=1
DAA* DAA#	@HL	0101 0101 1B00 0000	AC,(@HL) #: HL	← BCD(CF,AC) for add. ←HL+1	
DAS		0101 0110 0000 0000	AC	← BCD(CF,AC) for sub.	CF
DAS*	Rx	0101 0111 0XXX XXXX	AC,(Rx)	← BCD(CF,AC) for sub.	' ': B6=0 #: B6=1
DAS* DAS#	@HL	0101 0111 1B00 0000	AC,(@HL) #: HL	← BCD(CF,AC) for sub. ←HL+1	
LDS	Rx,D	0101 1DDD DXXX XXXX	AC,(Rx)	← D	
LDH LDH*	Rx,@HL	0110 000B 0XXX XXXX	AC,(Rx) *: HL	← H(T(@HL)) ← HL + 1	' ': B8=0 *: B8=1
LDL LDL*	Rx,@HL	0110 001B 0XXX XXXX	AC,(Rx) *: HL	← L(T(@HL)) ← HL + 1	' ': B8=0 *: B8=1
MRF1	Rx	0110 0000 1XXX XXXX	AC,(Rx)	← RFC3-0	
MRF2	Rx	0110 0001 1XXX XXXX	AC,(Rx)	← RFC7-4	
MRF3	Rx	0110 0010 1XXX XXXX	AC,(Rx)	← RFC11-8	
MRF4	Rx	0110 0011 1XXX XXXX	AC,(Rx)	← RFC15-12	
STA	Rx	0110 1000 0XXX XXXX	(Rx)	← AC	' ': B6=0 #: B6=1
STA STA#	@HL	0110 1000 1B00 0000	(@HL) #: HL	← AC ← HL+1	
LDA	Rx	0110 1100 0XXX XXXX	AC	← (Rx)	' ': B6=0 #: B6=1
LDA LDA#	@HL	0110 1100 1B00 0000	AC #: HL	← (@HL) ← HL+1	
MRA	Rx	0110 1101 0XXX XXXX	CF	← (Rx)3	
MRW MRW#	@HL,Rx	0110 1110 BXXX XXXX	AC,(@HL) #: HL	← (Rx) ←HL+1	' ': B7=0 #: B7=1
MWR MWR#	Rx,@HL	0110 1111 BXXX XXXX	AC,(Rx) #: HL	← (@HL) ←HL+1	' ': B7=0 #: B7=1
MRW	Ry,Rx	0111 0YYY YXXX XXXX	AC,(Ry)	← (Rx)	
MWR	Rx,Ry	0111 1YYY YXXX XXXX	AC,(Rx)	← (Ry)	
JB0	X	1000 0XXX XXXX XXXX	PC	← X	if AC0 = 1
JB1	X	1000 1XXX XXXX XXXX	PC	← X	if AC1 = 1
JB2	X	1001 0XXX XXXX XXXX	PC	← X	if AC2 = 1
JB3	X	1001 1XXX XXXX XXXX	PC	← X	if AC3 = 1
JNZ	X	1010 0XXX XXXX XXXX	PC	← X	if AC ≠ 0
JNC	X	1010 1XXX XXXX XXXX	PC	← X	if CF = 0
JZ	X	1011 0XXX XXXX XXXX	PC	← X	if AC = 0
JC	X	1011 1XXX XXXX XXXX	PC	← X	if CF = 1
CALL	X	1100 0XXX XXXX XXXX	STACK	← PC + 1	

			PC	← X	
JMP	X	1100 1XXX XXXX XXXX	PC	← X	
SRY	X	1101 0000 00XX XXXX	X5~0	:Set Ry Page (0~6,8~03Fh ) for Rx 0~03FFh	Insert by Compiler
ERY	X	1101 0010 00XX XXXX	X5~0	:Enable Ry Page (0~6,8~03Fh ) for Rx 0~03FFh Set & Lock	<ol style="list-style-type: none"> <li>1. Before execute "CLPG (X1=1)", Page still can be change by executing "ERY" again.</li> <li>2. Between jump location, can't have any "ERY/ERX/ELZ/CLPG" instructions.</li> <li>3. Interrupt will be masked by hardware till all page set be clear by "CLPG".</li> </ol>
SRX	X	1101 0100 0000 0XXX	X2~0	:Set Rx Page (1~7h)	Insert by Compiler
ERX	X	1101 0110 0000 0XXX	X2~0	:Enable Rx Page (1~7h) Set & Lock	<ol style="list-style-type: none"> <li>1. Before execute "CLPG (X0=1)", Page still can be change by executing "ERX" again.</li> <li>2. Between jump location, can't have any "ERY/ERX/ELZ/CLPG" instructions.</li> <li>3. Interrupt will be masked by hardware till all page set be clear by "CLPG".</li> </ol>
SLZ	X	1101 0100 0100 000X	X0	:Set Lz Page(1h)	Insert by Compiler
ELZ	X	1101 0110 0100 000X	X0	:Enable Lz Page(1h) Set & Lock	<ol style="list-style-type: none"> <li>1. Before execute "CLPG (X2=1)", Page still can be change by executing "ELZ" again.</li> <li>2. Between jump location, can't have any "ERY/ERX/ELZ/CLPG" instructions.</li> </ol>

					3. Interrupt will be masked by hardware till all page set be clear by "CLPG".
SPBK	X	1101 0110 1000 00XX	X3~0	:Set POM BANK X=00~03H	Insert by Compiler
CLPG	X	1101 0110 1010 1XXX	X2=1 X1=1 X0=1	:Release Lz Page Lock :Release Ry Page Lock :Release Rx Page Lock	
T2M3X	X	1101 0111 00XX XXXX	X5~0  SD15~12= 1011~1000 0111~0100 0011~0000  SD11~6  SD5~0	: Set Counter 17~12 (Timer3) Value  :Ctm=XCLK/INT/CX2/CX :Ctm=PH13/11/7/5 :Ctm=FREQ/PH15/3/9/  : Set Counter 11~6 (Timer1) Value  : Set Counter 5~0 (Timer2) Value	If TM3 is merged into TM2  Add. "SETDAT SD" to the next address  if TM1 is merged into TM2  XCLK only for SIO
T1XH		1101 0111 0100 0000	SD15~12= 1010~1000 0111~0100 0011~0000  SD11~6/0	:Ctm= INT/CX2/CX :Ctm=PH13/11/7/5 :Ctm=FREQ/PH15/3/9/  : Set Counter 5/11~0 (Timer1) Value if bit1,0 of STE <=> 01	Add. "SETDAT SD" to the next address
T2XH		1101 0111 0100 0100	SD15~12= 1011~1000 0111~0100 0011~0000  SD11~6  SD11/5~0	:Ctm= XCLK/INT/CX2/CX :Ctm=PH13/11/7/5 :Ctm=FREQ/PH15/3/9/  : Set Counter 11~6 (Timer1) Value  : Set Counter 11/5~0 (Timer2) Value if bit1,0 of STE =/<> 10	Add. "SETDAT SD" to the next address  if TM1 merge to TM2
T3XH		1101 0111 0100 1000	SD15~12= 1011~1000 0111~0100 0011~0000  SD11~6  SD11/5~0	:Ctm= XCLK/INT/CX2/CX :Ctm=PH13/11/7/5 :Ctm=FREQ/PH15/3/9/  : Set Counter 11~6 (Timer1) Value  : Set Counter 11/5~0 (Timer3) Value if bit1,0 of STE =/<> 11	Add. "SETDAT SD" to the next address  if TM1 merge to TM3
SPKXH	D	1101 0111 0100 110D	KO16~1	← SETDAT SD(16bits)	Add. "SETDAT SD" to the next address

			D=1 D=0  SD15~0	: KEY_S release by scanning cycle : KEY_S release by normal key scanning  : Enable KO16~1=1	
SHLX		1101 0111 0101 1100	IDBF12~0	← SETDAT SD(16bits) SD : 0000~1FFFH	Add. "SETDAT SD" to the next address
CPHLH		1101 0111 0101 1110	(PC+2)	← force "NOP" if SETDAT SD(16bits) = IDBF12~0	Add. "SETDAT SD" to the next address Can't set ERX/ERY/ELZ/CLPG to PC+2
CAC	X	1101 0111 0110 XXXX	X>=AC: STACK PC(SET) PC  X<AC: PC	← PC+X+2 ← PC+AC+1 ← SETDAT SD(16bits)  ← PC+X+2	Add. "SETDAT SD" to the next X(<16) Addresses range
JAC	X	1101 0111 0111 XXXX	X>=AC: PC(SET) PC  X<AC: PC	← PC+AC+1 ← SETDAT SD(16bits)  ← PC+X+2	Add. "SETDAT SD" to the next X(<16) Addresses range
T1TH T1TH#	@HL	1101 0111 1000 B000	Timer1  '#' : HL  TD15~12= 1010~1000 0111~0100 0011~0000  TD11~6/0	← T(@HL)16bits  ← HL+2  :Ctm= INT/CX2/CX :Ctm=PH13/11/7/5 :Ctm=FREQ/PH15/3/9/  : Set Counter 5/11~0 (Timer1) Value if bit1,0 of STE =/<> 10	' ' : B3=0 '#' : B3=1
T2TH T2TH#	@HL	1101 0111 1001 B000	Timer2(2->1)  '#' : HL  TD15~12= 1011~1000 0111~0100 0011~0000  TD11~6  TD11/5~0	← T(@HL)16bits  ← HL+2  :Ctm= XCLK/INT/CX2/CX :Ctm=PH13/11/7/5 :Ctm=FREQ/PH15/3/9/  : Set Counter 11~6 (Timer1) Value  : Set Counter 11/5~0 (Timer2) Value if bit1,0 of STE =/<> 11	' ' : B3=0 '#' : B3=1  if TM1 merge to TM2
T3TH T3TH#	@HL	1101 0111 1010 B000	Timer3(3->1)	← T(@HL)16bits	' ' : B3=0 '#' : B3=1

			'#' : HL TD15~12= 1011~1000 0111~0100 0011~0000 TD11~6 TD11/5~0	← HL+2 : Ctm= XCLK/INT/CX2/CX : Ctm=PH13/11/7/5 : Ctm=FREQ/PH15/3/9/ : Set Counter 11~6 (Timer1) Value : Set Counter 11/5~0 (Timer3) Value	if TM1 merge to TM3
SPKTH SPKTH#	D,@HL	1101 0111 1011 B00D	KO16~1 '#' : HL D=1 D=0 TD15~0	← T(@HL)16bits ← HL+2 : KEY_S release by scanning cycle : KEY_S release by normal key scanning : Enable KO16~1=1	' ' : B3=0 '#' : B3=1
RVL	Rx	1101 1000 0XXX XXXX	AC,(Rx)	← IDBF0~3	
RVH	Rx	1101 1001 0XXX XXXX	AC,(Rx)	← IDBF4~7	
RVU	Rx	1101 1010 0XXX XXXX	AC,(Rx)	← IDBF8~11	
RVV	Rx	1101 1011 0XXX XXXX	AC,(Rx)0	← IDBF12	
TM3	Rx	1101 1100 0XXX XXXX	Timer3	← (Rx) & AC	
TM3 TM3#	@HL	1101 1101 0000 B000	Timer3 '#' : HL	← T(@HL) ← HL+1	' ' : B3=0 '#' : B3=1
TM3X	X	1101 111X XXXX XXXX	X8,7,6=111 X8,7,6=110 X8,7,6=101 X8,7,6=100 X8,7,6=011 X8,7,6=010 X8,7,6=001 X8,7,6=000 X5~0	: Ctm = PH13 : Ctm = PH11 : Ctm = PH7 : Ctm = PH5 : Ctm = FREQ : Ctm = PH15 : Ctm = PH3 : Ctm = PH9 : Set Timer3 Value	
TMS	Rx	1110 0000 0XXX XXXX	AC3,2 = 11 AC3,2 = 10 AC3,2 = 01 AC3,2 = 00 AC1,0,PB3~0	: Ctm = FREQ : Ctm = PH15 : Ctm = PH3 : Ctm = PH9 : Set Timer1 Value	
TMS TMS#	@HL	1110 0001 0000 B000	Timer1 '#' : HL	← T(@HL) ← HL+1	' ' : B3=0 '#' : B3=1
TMSX	X	1110 001X XXXX XXXX	X8,7,6=111 X8,7,6=110 X8,7,6=101 X8,7,6=100 X8,7,6=011 X8,7,6=010 X8,7,6=001 X8,7,6=000 X5~0	: Ctm = PH13 : Ctm = PH11 : Ctm = PH7 : Ctm = PH5 : Ctm = FREQ : Ctm = PH15 : Ctm = PH3 : Ctm = PH9 : Set Timer1 Value	

TM2	Rx	1110 0100 0XXX XXXX	Timer2	← (Rx) & AC	
TM2 TM2#	@HL	1110 0101 0000 B000	Timer2 # : HL	← T(@HL) ← HL+1	' : B3=0 # : B3=1
TM2X	X	1110 011X XXXX XXXX	X8,7,6=111 X8,7,6=110 X8,7,6=101 X8,7,6=100 X8,7,6=011 X8,7,6=010 X8,7,6=001 X8,7,6=000 X5~0	: Ctm = PH13 : Ctm = PH11 : Ctm = PH7 : Ctm = PH5 : Ctm = FREQ : Ctm = PH15 : Ctm = PH3 : Ctm = PH9 : Set Timer2 Value	
SHE	X	1110 1000 X0XX XXX0	X7 X5 X4 X3 X2 X1	: Enable HEF7 : Enable HEF5 : Enable HEF4 : Enable HEF3 : Enable HEF2 : Enable HEF1	TMR3 KEY_S TMR2 PDV INT/SIO TMR1
SIE*	X	1110 1001 XXXX XXXX	X7 X6 X5 X4 X3 X2 X1 X0	: Enable IEF7 : Enable IEF6 : Enable IEF5 : Enable IEF4 : Enable IEF3 : Enable IEF2 : Enable IEF1 : Enable IEF0	TMR3 RFC KEY_S TMR2 PDV INT/SIO TMR1 A,C,DPT
PLC	X	1110 101X XXXX XXXX	X8 X7-0	: Reset PH15~11 : Reset HRF7-0	
SRF	X	1110 1100 00XX XXXX	X5~0  X5 X4 X3 X2 X1 X0	:Enable RFC5~0 Output  : Enable CX Control : Enable TM2 Control : Enable Counter : Enable RFC2 Output : Enable RFC1 Output : Enable RFC0 Output	<TYPE B for RFC>  <TYPE A for RFC>  RFC2=RH RFC1=RT RFC0=RR
SRE	X	1110 1101 0X0X X000	X6 X4 X3	:Enable SRF6(A port) :Enable SRF4(C port) :Enable SRF3(D port)	
FAST	(X)	1110 1110 0000 0XXX	B/SCLK X=7 X=6 X=5 X=4 X=3 X=2 X=1 X=0 or None	: High Speed Clock :B/SCLK=FTOSC/128 :B/SCLK=FTOSC/64 :B/SCLK=FTOSC/32 :B/SCLK=FTOSC/16 :B/SCLK=FTOSC/8 :B/SCLK=FTOSC/4 :B/SCLK=FTOSC/2 :B/SCLK=FTOSC	
SLOW		1110 1110 1000 0000	SCLK	: Low Speed Clock	
CPHL	X	1110 1111 XXXX XXXX	(PC+1)	← force "NOP" if X7~0=IDBF7~0	Can't set ERX/ERY/ ELZ/CLPG to PC+1
SPK	Rx	1111 0000 0XXX XXXX	KO1~16	← (Rx) & AC	
SPK SPK#	@HL	1111 0001 0000 B000	KO1~16 # : HL	← T (@HL) ← HL+1	' : B3=0 # : B3=1



SPKX	X	1111 0010 XXXX XXXX	X6=1 X6=0  X7,5,4=000 X7,5,4=001 X7,5,4=010 X7,5,4=10X  X7,5,4=110   X7,5,4=111	: KEY_S release by scanning cycle : KEY_S release by normal key scanning  : Set one of KO1~16 =1 by X3~0 : Set all = 1 : Set all Hi-z : Set eight of KO1~16 =1 by X3 X3=0 => KO1~8 X3=1 => KO9~16 : Set four of KO1~16 =1 by X3,2 X3,2=00 => KO1~4 X3,2=01 => KO5~8 X3,2=10 => KO9~12 X3,2=11 => KO13~16 : Set two of KO1~16 =1 by X3,2,1 X3~1=000=>KO1,2 X3~1=001=>KO3,4 X3~1=010=>KO5,6 X3~1=011=>KO7,8 X3~1=100=>KO9,10 X3~1=101=>KO11,12 X3~1=110=>KO13,14 X3~1=111=>KO15,16	
RTS		1111 0100 0000 0000	PC	← STACK (CALL Return)	
MRI MRI#	X	1111 0100 0001 BOXX	X1,0=00 X1,0=01 X1,0=10 X1,0=11  '#' : HL	: (RILH)3~0 ←(@HL) : (RILH)7~4 ←(@HL) : (RILH)11~8 ←(@HL) : (RILH)15~12 ←(@HL)  : ← HL+1	' ' : B3=0 '#' : B3=1
SBZ	X	1111 0100 0010 00XX	X1=0 X1=1  X0=0 X0=1	<set BZB Pad> :BZB :FREQB only  <set BZ Pad> :BZ :FREQ only	Initial  Initial
SRP	X	1111 0100 0010 1XXX	X2  X1  X0	: Enable Timer3 repeat set if RL3=1 : Enable Timer2 repeat set if RL2=1 : Enable Timer1 repeat set if RL1=1	
STM	X	1111 0100 0011 00XX	X1,0=00 X1,0=01 X1,0=10 X1,0=11	: TM1,2,3 is independent : TM2(2=>1) : TM3(3=>1) : TM2(2=>1=>3)	Initial(X1,0=00)
DISTM	X	1111 0100 0011 1XXX	X2~0	: Disable TM3~1 Count	

SCNT	X	1111 0100 01XX XX00	X5=0 X5=1  X4=0 X4=1  X3,2=00 X3,2=01 X3,2=10 X3,2=11	: Enable CX set : Enable CX2 set  Counter clock source for not CX/2 control Mode : CX/2 : FREQ  Control Mode : Software : TM2 : CX/2 – One Cycle : CX/2 – High Level	<TYEP B for RFC>  initial
SCC	X	1111 0100 1XXX XXXX	X6 = 1 X6 = 0 X5 = 1 X4 = 1 X3 = 1 X2,1,0=001 X2,1,0=010 X2,1,0=100	: Cfq = XCLK : Cfq = PH0 : Set P(A) Cch : Set P(C) Cch : Set P(D) Cch : Cch = PH10 : Cch = PH8 : Cch = PH6	
SCA	X	1111 0101 00XX X000	X5 X4 X3	: Enable SEF5(A1-4) : Enable SEF4(C1-4) : Enable SEF3(D1-4)	
SPE	X	1111 0101 010X XXXX	X4 X3~0	: Set E4-1 Pull-Low : Set E4-1 I/O	
SCX	X	1111 0101 0110 00XX	X1 X0	: Enable SEF1(CX2) : Enable SEF0(CX)	<TYEP B for RFC>
SXCLK	X	1111 0101 0110 01XX	X1  X0	: Force clock source of RFC 16bits counter to XCLK  : 0/1 to set XCLK=BCLK/CFOSC	
STE	X	1111 0101 0110 1XXX	X2  X1,0=00 X1,0=01 X1,0=10 X1,0=11	: Replace timer1 read of RTM by extension bits & replace timer2 read of RTM by timer1 bits if X1,0=01  : TM1,2,3 is normal 6bits : TM1=>12bits(STM:00) : TM2=>12bits(STM:X0) : TM3=>12bits(STM:0X)	Initial(X2~0=000)
ST3OV	X	1111 0101 0111 01XX	X1 X0	: Mask one cycle of Ctm2 when Timer3 overflow : Mask one cycle of Cfq when Timer3 overflow	
ADJ	X	1111 0101 0111 1XXX	X2  X1,0=00 X1,0=01 X1,0=10	: 0/1 to inc./dec. one PH0 cycle for PDV when Timer overflow set by X1,0  : Normal PDV : Adjust PDV by TM1 : Adjust PDV by TM2	

			X1,0=11	: Adjust PDV by TM3	
SPA	X	1111 0101 100X XXXX	X4 X3~0	: Set A4-1 Pull-Low : Set A4-1 I/O	
SPB	X	1111 0101 101X XXXX	X4 X3~0	: Set B4-1 Pull-Low : Set B4-1 I/O	
SPC	X	1111 0101 110X XXXX	X4  X3-0	: Set C4-1 Pull-Low / Low-Level-Hold : Set C4-1 I/O	
SPD	X	1111 0101 111X XXXX	X4 X3-0	: Set D4-1 Pull-Low : Set D4-1 I/O	
SF	X	1111 0110 XXXX XXXX	X7 X6 X5  X4 X3 X2 X1 X0	: Reload 1 Set : Reload 3 Set : Enable all Timer Counter update & latch : WDT Enable : HALT after EL : EL LIGHT On : BCF Set : CF Set	
RF	X	1111 0111 XXXX OXXX	X7 X6 X5  X4 X2 X1 X0	: Reload 1 Reset : Reload 3 Reset : Disable all Timer Counter latch : WDT Reset : EL LIGHT Off : BCF Reset : CF Reset	
ELC	X	1111 10XX XXXX XXXX	(ELP) X8,7,6=111 X8,7,6=110 X8,7,6=101 X8,7,6=100 X8,7,6=011 X8,7,6=000  X9,5,4=101 X9,5,4=100 X9,5,4=x11 X9,5,4=x10 X9,5,4=001 X9,5,4=000  (ELC) X3,2=11 X3,2=10 X3,2=01 X3,2=00 X1,0=11 X1,0=10 X1,0=01 X1,0=00	BCLK/8 BCLK/4 BCLK/2 BCLK FREQB PH0  2/3 3/4 1/1 1/2 1/3 1/4  PH5 PH6 PH7 PH8 1/1 1/2 1/3 1/4	
ALM	X	1111 110X XXXX XXXX	X8,7,6=111 X8,7,6=100 X8,7,6=011 X8,7,6=010	: FREQ : DC1 : PH3 : PH4	

			X8,7,6=001 X8,7,6=000 X5~0	: PH5 : DC0 ← PH15~10	
SF2	X	1111 1110 0XXX XXXX	X6 X5 X3  X2 X1 X0	: Enable CX2 Counter : Enable CX Counter : Enable INT powerful Pull-low : Close all Segments : Dis-ENX Set : Reload 2 Set	*B *B
RF2	X	1111 1110 1XXX XXXX	X6 X5 X3  X2 X1 X0	: Disable CX2 Counter : Disable CX Counter : Disable INT powerful Pull-low : Release Segments : Dis-ENX Reset : Reload 2 Reset	*B *B
HALT		1111 1111 0000 0000	Halt Operation		
PTR		1111 1111 0111 1111	T(@HL)	←RILH	
STOP		1111 1111 1000 0000	Stop Operation		

\*A : TYPE A for RFC

\*B : TYPE B for RFC

## Symbol Description

AC	: Accumulator	D	: Immediate Data
ACB	: Invert of Accumulator	DB	: Invert of Immediate Data
ACn	: Accumulator bit n	PC	: Program Counter
X	: Address or Set data	CF	: Carry Flag
Rx	: Address of Data RAM	ZERO	: Zero Flag
(Rx)n	: Bit n of (Rx)	WDF	: Watch-Dog Timer Enable Flag
Ry	: Address of working register	PDV	: Pre-Divider
BCF	: Back-up Flag	BCLK	: System clock stop only in STOP condition
IEFn	: Interrupt Enable Flag	SEFn	: Switch Enable Flag
HRFn	: HALT Release Flag	SRFn	: STOP Release Enable Flag
HEFn	: HALT Release Enable Flag	SCFn	: Start Condition Flag
TMR	: Timer Overflow Release Flag	Cch	: Clock Source of Chattering Detector
Ctm	: Clock Source of Timer	Cfq	: Clock Source of Frequency Generator
Lz	: Address of LCD data	FREQ	: Frequency Generator setting Value
RFOVF	: RFC Overflow Flag	( )	: Content of Address Register
MUI	: Multiplication Input Register	MU	: Multiplication High nibble Result Register
@HL	: Address assigned by Index Register	HL	: Index Register
H(T@HL)	: High Nibble of Index ROM data	L(T@HL)	: Low Nibble of Index ROM Data
IDBF	: Content of Index Register		
T@HL	: Index ROM address assigned by Index Register		
CSF	: Clock Source Flag	DA	: BCD for result
FTOSC	: Fast Oscillation clock	PGMF	: Program BUSY or WR-FAIL Flag

(@HL) : 4bits data type for Data RAM

T(@HL) : 8 bits data type for Index ROM

T(@HL)16bits : 16 bits data type for Index ROM

HL+1 : +1 to index address bit0

HL+2 : mask index address bit0, and +1 to bit1

**MWM/MMW Rm Assignment**

Rm	R/W	Instruction	BIT3	BIT2	BIT1	BIT0		
0	R	MMW Ry,0	IPF3	IPF2	IPF1	IPF0		
	W	MWM 0,Ry	OPF3	OPF2	OPF1	OPF0		
1	W	MWM 1,Ry	SPF3	SPF2	SPF1	SPF0		
2	R	MMW Ry,2	SDAT3	SDAT2	SDAT1	SDAT0		
	W	MWM 2,Ry						
3	R	MMW Ry,3	SDAT7	SDAT6	SDAT5	SDAT4		
	W	MWM 3,Ry						
4	W	MWM 4,Ry	SCR3	SCR2	SCR1	SCR0		
5	<W> I2C UART SPI	MWM 5,Ry	<SCTL3> I2CEN UARTEN SPIEN	<SCTL2> STRSTP REN MSTR	<SCTL1> START RENRLS BIDIROE	<SCTL0> STOP TB8 LSBF		
	<R> I2C UART SPI		MMW Ry,6	<SSTA3> ACTF RCVOVF /TXOF RCVOVF	<SSTA2> ACKF RCVBF /TXSF RCVBF	<SSTA1> EAF RB8F  SSI	SBUSY	
6	<W> I2C UART SPI	MWM 6,Ry		<SUT13> SDOCHK TXDCHK TXOCHK	<SUT12> ACKOSTP CLRXF CLRXF	<SUT11> WTACKI0 RXCK SSOE	<SUT10> MKACKI TXCK FSNSS0	
	<R> I2C UART SPI		MMW Ry,7	<SSCF3> IRQF RXSF MSF	<SSCF2> EROF RXBF WCOF/EROF	<SSCF1> TRBF TXBF TRBF	INTF	
7	<W> I2C UART SPI	MWM 7,Ry		<SSRE3> IRQFEN RXSFEN MSFEN	<SSRE2> EROFEN RXBFEN WCOFEN /EROFEN	<SSRE1> TRBFEN TXBFEN TRBFEN	INTFEN	
	W		MWM 8,Ry	SIOTYP2	SIOTYP1	DSIOPHL	SPLF	
9	R	MMW Ry,9	-	-	VDX4	LBF		
	W	MWM 9,Ry	0	0		ENLBD		
A	R	MMW Ry,A	VDL3	VDL2	VDL1	VDL0		
	W	MWM A,Ry						
B	R	MMW Ry,B	LBD3	LBD2	LBD1	LBD0		
	W	MWM B,Ry						
C	<W> I2C UART SPI	MWM C,Ry	<SIO3> 0 0 1	<SIO2> 0 1 CPOL	<SIO1> 0 TRB8 CPHA	<SIO0> 1 UART1W SPBIR		
	D,E Don't Use							
	F		R	MMW Ry,F	VDX3	VDX2	VDX1	VDX0
			W	MWM F,Ry				

IPF3~0 : IOF4~1 input Data.

OPF3~0 : set IOF4~1 output data.

SPF3~0 : 1 for set IOF4~1 to Output(initial value = 0000).

SPLF : 1 for enable IOF4~1 Pull-low(initial value = 1).

- SDAT7~0 : SIO Transmit and Receive Data.  
 Read SDAT7~4 register will clear RCVOVF & RCVBF.  
 Write data to SDAT7~4 register will start a transfer in master mode.
- SCR3~0 : SIO clock source(no initial value).  
 SCR3=0: enable set SXCLK Clock Rate by SCR2~0  
 000 => XCLK/2(XCLK/4 for I2C)  
 001 => XCLK/4(XCLK/8 for I2C)  
 010 => XCLK/8(XCLK/16 for I2C)  
 011 => XCLK/16(XCLK/32 for I2C)  
 100 => XCLK/32(XCLK/64 for I2C)  
 101 => XCLK/64(XCLK/128 for I2C)  
 110 => XCLK/128(XCLK/256 for I2C)  
 111 => XCLK/256(XCLK/2 for I2C)
- SCR3,2=10(11) : enable set TX&RX(set RX independently in UART mode) clock by SCR1,0 ( SPI & I2C don't care RX clock)  
 00 => SXCLK(baud rate = Fsxclk for I2C , Fsxclk/16 for UART , Fsxclk for SPI)  
 01 => FREQ(baud rate = Ffreq/2 for I2C , Ffreq/16 for UART , Ffreq for SPI)  
 10 => TM2(baud rate = Ftm2ov/2 for I2C , Ftm2ov/16 for UART , Ftm2ov for SPI)  
 11 => TM3(baud rate = Ftm3ov/2 for I2C , Ftm3ov/16 for UART , Ftm3ov for SPI)  
 SCR3,2=11(RX) is no use for I2C & SPI.  
 tm2ov : timer2 overflow rate = F(Ctm2) / (timer2 set value+1)  
 tm3ov : timer3 overflow rate = F(Ctm3) / (timer3 set value+1)
- If no use FREQ/TM2/TM3 for SCR of SIO & active for other function, set SCR before enter SIO Mode to sure save current.  
 When set SCR=FREQ, disable FREQ for other function before enter SIO mode to save current & control FREQ by SIO, execute FRQ(X) instruction to set Cfq=XCLK for synchronizing with instruction timing & initial state before enable SIO mode.  
 Before set SCR=TM2/TM3, set Ctm2/Ctm3=XCLK to force TMRL2/3=1 & synchronizing with instruction timing & control TM2/3 by SIO
- <SCTL3~0> : enable & options for SIO(initial value = 0000)  
 <SCTL0> : 1 for set I2C(STOP) if I2CEN=1.  
 : used for UART(TB8) to set 9<sup>th</sup> transmit data bit in the mode of TRB8=1  
 : 1/0 for set SPI(LSBF) to set data transfer first by LSB/MSB  
 <SCTL1> : 1 for set I2C(START) if I2CEN=1.  
 for set UART(RENRLS)=1 to disable receive interrupt received if “stop bit” / “9<sup>th</sup> data bit” is 0 in the mode of TRB8=0/1.  
 for set SPI(BIDIROE)=1 to enable MOSI/MISO output for Master/Slave Mode in the Bidirectional mode of operation (SPBIR=1).  
 <SCTL2> : 1 for set I2C(STRSTP) if I2CEN=1.  
 for set UART(REN)=1 to enable receive by RXD/TXD pin when UART1W=0/1.  
 for set SPI(MSTR)=1/0 to enter Master/Slave mode  
 <SCTL3> : 1 for enable I2C/UART/SPI mode

<SCTL2~0> for I2C (SCTL3=1) :

STRSTP	START	STOP	Description
X	0	0	Nothing
0	0	1	Sent STOP bit after ACKI/ACKO bit by WDATA/RDATA for write/read mode.
0	1	0	Sent START bit before MSB of data by WDATA
0	1	1	Sent START bit before MSB of data by WDATA & sent STOP bit after ACKI/ACKO bit for LSB of data =0/1.
1	0	1	Direct sent STOP bit
1	1	0	Direct sent START bit & force to Write Mode(don't care LSB=1) after write SDAT7~4.
1	1	1	Direct sent START & STOP bits

- SBUSY : SIO BUSY Flag(Read Only & set by H/W when a SIO transfer in progress)  
 <SSTA1> : for I2C(EAF) to read external active flag by IRQ or others master active.(No support  
 IRQ for SIOTYP=11 mode)  
 for UART RB8 Flag if set TRB8=1.  
 for SPI(SS1) to read SSB input invert state.
- ACKF : for I2C ACKI Flag, and ACKF=1 if ACKI fail. H/W auto-sent stop bit & set EROF=1 by  
 EROFEN=1 if ACKF=1 & MKACKI=0.
- ACTF : for I2C Active Flag, and ACTF=1 from start to stop.
- RCVBF : for UART/SPI Receive Buffer Full Flag(Set by H/W at the end of a data transfer, and  
 set SCTL3=0 or write CLRBF=1 or read the register of SDAT7~4 will clear this flag). In  
 UART mode, enable this flag by set TXDCHK=0.
- RCVOVF : for UART/SPI Receive Buffer Overrun Flag(Set by H/W at the end of a data transfer,  
 and set SCTL3=0 or write CLROVF=1 or read the register of SDAT7~4 will clear this  
 flag). In UART mode, enable  
 this flag by set TXDCHK=0.
- TXSF : for UART TXD Start Flag (Set by H/W if TXD have falling edge happen when TX in  
 standby state & REN=0 in UART1W=1 mode, and set SCTL3=0 or write CLRXF=1 or  
 write the register of SDAT7~4 will clear this flag.), only enable this flag by set  
 TXDCHK=1 in UART mode.
- TXOF : for UART TXD Output Fail Flag(Set by H/W if output data & start bit don't match with  
 TXD pin, and set SCTL3=0 or write CLRXF=1 or write the register of SDAT7~4 will  
 clear this flag.), only enable this flag by set TXDCHK=1 in UART mode.
- <SUTI3~0> : Utility option & function for SIO(initial value = 0000)
- <SUTI0> : for set I2C(MKACKI)=1 to disable generate STOP bit & EROF if ACKI=High, but still  
 make ACKF=1.  
 for UART(TXCK), set 1 to enable transmit clock always, set TXCK=1 can make all  
 transmit on same trace of Baud Rate if RX count of target IC can't auto-reset by each  
 START bit, TXCK=1 also can avoid error TXOF by race between TX start and SIO  
 clock if RX and TX set same clock source.  
 for SPI(FSNSS0), set 1 to force NSS pin output low always if SSOE=1.

- <SUTI1> : for set I2C(WTACKI0)=1 to wait ACKI=0.  
for set UART(RXCK)=1 to enable RX clock always for reduce error START to make RXSF=1 by majority detect.  
1 for SPI(SSOE) enable SSB output in master mode.
- <SUTI2> : for set I2C(ACKOSTP)=1 to generate STOP bit replace ACKO bit.  
for set UART(CLRXF)=1 to clear RCVBF/TXSF & RCVOVF/TXOF  
for set SPI(CLRXF)=1 to clear RCVBF & RCVOVF.
- <SUTI3> : for set I2C(SDOCHK)=1 to enable EROF function .  
for set UART(TXDCHK)=1 to change enable RCVBF/RCVOVF to TXSF/TXOF function, set TXCK=1 to avoid error TXOF=1 if RX and TX have same clock source & one condition of RXCK=1 and SBUSY=1 by RX at start TX.  
for set SPI(TXOCHK)=1 to change WCOF to EROF function .
- INTF : INT pin interrupt/halt release flag
- <SSCF1> : I2C&SPI(TRBF) interrupt/halt release flag for the end of byte data transfer. Read/write SDAT7~4 or set STCL3=0 or set SSRE1=0 will clear this flag  
UART(TXBF) transmit interrupt/halt release flag for the end of byte data transmit, disable by TXOF=1 or TXSF=1. Write SDAT7~4 or set STCL3=0 or set SSRE1=0 will clear this flag  
Enable SSCF1 by set SSRE1=1
- <SSCF2> : I2C(EROF) transmit error interrupt/halt release flag for transmit data or ACKO(ACKOSTP=0) no match to SDA. Write SDAT7~4 or set STCL3=0 or set SSRE2=0 will clear this flag.  
UART(RXBF) receive interrupt/halt release flag for the end of byte data receive. Read SDAT7~4 or set STCL3=0 or set SSRE2=0 will clear this flag.  
SPI(WCOF) write collision interrupt/halt release flag by set TXOCHK=0 for writing data to SDAT7~4 when SBUSY=1. Write SDAT7~4 or set STCL3=0 or set SSRE2=0 will clear this flag.  
SPI(EROF) transmit error interrupt/halt release flag by set TXOCHK=1 for transmit data no match to MOSI/MISO output pin. Write SDAT7~4 or set STCL3=0 or set SSRE2=0 will clear this flag.  
Enable SSCF2 by set SSRE2=1.
- <SSCF3> : for I2C(IRQF) IRQ(Interrupt Request) interrupt/halt release flag for SDA pin receive falling edge at SCL pin = High when ACTF=0. Write SDAT7~4 or set STCL3=0 or set SSRE3=0 will clear this flag.  
for UART(RXSF) receive start interrupt/halt release flag for start bit of receive . Read SDAT7~4



or set STCL3=0 or set SSRE3=0 will clear this flag.

for SPI(MSF) is used as :

- a. mode fault interrupt/halt release flag with falling edge of SSB in master mode & SSOE=0, auto change to slave mode immediately by H/W.
- b. other master active start&stop interrupt/halt release flag with falling & rising edge of SSB in master mode & SSOE=1
- c. slave SSB start&stop interrupt/halt release flag with falling&rising edge of SSB at SBUSY=0 in slave mode.
- d. slave fault interrupt/halt release flag with rising edge of SSB at SBUSY=1 in slave mode. Auto disable output immediately by H/W. Clear SBUSY & re-work by re-enable SPI.
- e. slave SCK start interrupt/halt release flag with first edge of SCK at SBUSY=0 in slave mode & SSB pin no use.

set STCL3=0 or set SSRE3=0 will clear this flag.

Enable SSCF3 by set SSRE3=1

- INTFEN : 1 for enable INT pin interrupt/halt release(initial value = 0).
- <SSRE3~1> : SSRE3~1 is forced to 0 when SCTL3=0(initial value = 000).
- <SSRE1> : 1 for enable I2C/SPI(TRBF) interrupt/halt release at the end of byte data transfer.  
1 for enable UART(TXBF) interrupt/halt release at the end of byte data transmit.
- <SSRE2> : 1 for enable I2C(EROFEN) interrupt/halt release if transmit data or ACKO(ACKOSTP=0) no match to SDA  
1 for enable UART(RXBF) interrupt/halt release at the end of byte data receive.  
1 for enable SPI(WCOFEN) interrupt/halt release(by set TXOCHK=0) if write data to SDAT7~4 when SBUSY=1.  
1 for enable SPI(EROFEN) interrupt/halt release(by set TXOCHK=1) if transmit data no match to MOSI/MISO output pin.
- <SSRE3> : 1 for I2C(IRQEN) to enable interrupt/halt release by SDA pin receive falling edge at SCL pin = High when ACTF=0.  
1 for UART(RXSF) to enable interrupt/halt release by start bit of receive.  
1 for SPI(MSFEN) to enable interrupt/halt release by edge of SSB or first edge of SCK if SSB no use.

SIOTYP2,1 : I2C/UART/SPI pins input/output type.

SIOTYP2,1		00(initial)	01	10	11
I2C	SDA(I/O) ,SCL(O)	NOD(I/O) ,NOD(O) (standard & for Multi-Master)	NOD(I/O) ,NOD(O) (for Multi-Master)	DC(O)/NOD(I) ,DC(O) (For Single-Master)	DC(I/O) ,DC(O) (For Single-Master)
UART	TXD(I/O) ,RXD(I)	NPOD(O)/NOD(I) ,NOD(I) (standard)	NOD(I/O) ,NOD(I) (For Multi-Master)	DC(O)/NOD(I) ,NOD(I) (For Single-Master & Multi-Slave)	DC(I/O) ,DC(I) (For Single-Master & Single-Slave)
SPI		(standard & for Sub-Master)	(For Multi-Master)	(For Single-Master & Multi-Slave)	(For Single-Master & Single-Slave)
(Master)	MISO(I) ,MOSI(I/O) ,SCK(O) ,SSB(I/O)	NOD(I) ,NOD(I/O) ,NOD/POD(O) ,DC(I/O)	NOD(I) ,NOD(I/O) ,NOD/POD(O) ,NOD(I/O)	NOD(I) ,NOD(I/O) ,DC(O) ,DC(I/O)	DC(I) ,DC(I/O) ,DC(O) ,DC(I/O)
(Slave)	MISO(I/O) ,MOSI(I) ,SCK(I) ,SSB(I)	NOD(I/O) ,NOD(I) ,NOD/POD(I) ,DC(I)	NOD(I/O) ,NOD(I) ,NOD/POD(I) ,NOD(I)	NOD(I/O) ,NOD(I) ,DC(I) DC(I)	DC(I/O) ,DC(I) ,DC(I) ,DC(I)*SPI-1

POD : P-type Normal Open Drain.  
 NOD : N-type Normal Open Drain.  
 NPOD : N-type Pseudo Open Drain.  
 DC : CMOS output.

DSIOPHL : 1 for disable I2C/UART/SPI Pull-High/Low Resistance(initial value=0). Control Pull-High/Low Resistance turn on/off by hardware if DSIOPHL=0.

<SIO3~0> : I2C/UART/SPI select & Option (initial value = 0000)  
 SIO3~0=0001 : for I2C Mode(Master Only)  
 SIO3~2=01 : for UART Mode & set TRB8/UART1W by SIO1/0  
 TRB8 : 0/1 for 8/9bits UART.  
 UART1W : 0/1 for transmit & receive by TXD&RXD / TXD only  
 In SIOTYP=11 mode, before set REN=1 need to sure input-High start to avoid error by floating.

SIO3=1 : for SPI Mode & set CPOL/CPHA/SPBIR by SIO2/1/0  
 CPOL : 0/1 for SCK is low/high in idle mode  
 CPHA : 0/1 for Data sampled on first/second edge of SCK period  
 SPBIR : 1 for enable Bidirectional mode of operation(SPBIR=1 only enable  
 MOSI/MISO(=>MOMI/SISO) one pin active in Master/Slave mode. In this mode, input is always enable, but output is enable by BIDIROE=1).

LBF : Low Battery Detect Flag.  
 ENLBD : 1 for generating pulse to enable Low Battery Detect(initial value = 0).

VDL3~0: Set VDL regulator output voltage.  
 ±50mV for one step voltage.  
 <VDL for VL2>  
 Initial value=6h for VDL=2.10V.  
 VDL=2.55/1.80V for VL3~0=F/0h.  
 <VDL for VL1>  
 Initial value=2h for VDL=1.05V.  
 VDL=1.70/0.95V for VL3~0=F/0h.

LBD3~0: Set Low Battery Detect Voltage.

±50mV for one step voltage.

<LBD for Normal 3V range>

Initial value=8h for LBD=2.40V.

LBD=2.75/2.00V for LBD3~0=F/0h.

<LBD for Low 3V range>

Initial value=Ch for LBD=1.95V.

LBD=2.10/1.75V for LBD3~0=F/8h.

<LBD for 1.5V>

Initial value=0h for LBD=1.35V.

LBD=1.70/1.35V for LBD3~0=7/0h.

VDX4~0 : Set VDX regulator output voltage.

Initial value=00h for VREG=1.20V.

VDX=2.75/1.20V for VDX4~0=1F/00h.