

TMI8262 Dual-Bridge Motor Controller IC

FEATURES

- 8-V to 40-V Operating Supply Voltage Range
- 1.6-A Maximum Drive Current at 24 V and TA=25°C
- Dual H-Bridge Current Control Motor
 - Drive a Bipolar Stepper or Two DC Motors
 - Four Level Winding Current Control
- Multiple Decay Modes
 - Mixed Decay
 - Slow Decay
 - Fast Decay
- Industry Standard Parallel Digital Control Interface
- Low Current Sleep Mode
- Built In 3.3-V Reference Output Small Package and Footprint
- Protection Features
 - Overcurrent Protection (OCP)
 - Thermal Shutdown (TSD)
 - VM Undervoltage Lockout (UVLO)
 - Fault Condition Indication Pin (nFAULT)
- Small Packages
 - TMI8262: HTSSOP28
 - TMI8262Q: QFN5x5-28

APPLICATIONS

- Automatic Teller Machines
- Video Security Cameras
- Printers and Scanners
- Office Automation Machines
- Gaming Machines
- Factory Automation

GENERAL DESCRIPTION

The TMI8262 provides an integrated motor driver solution for printers, scanners, and other automated equipment applications. The device has two H-bridge drivers, and can drive a bipolar stepper motor or two DC motors. The output driver block for each consists of N-channel power MOSFET's configured as full H-bridges to drive the motor windings. The TMI8262 is capable of driving up to 1.6-A of output current.

A simple parallel digital control interface is compatible with industry-standard devices. Decay mode is programmable.

Internal shutdown functions are provided for over current protection, short circuit protection, under voltage lockout and overtemperature.

The TMI8262 and TMI8262Q which comply with ROHS specifications, and the lead frame is 100% lead-free.

TYPICAL APPLICATION

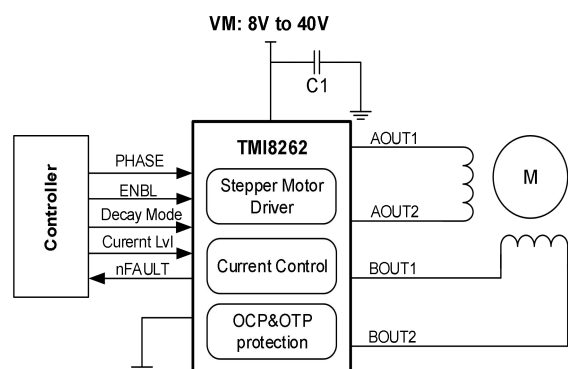

Figure 1. Basic Application Circuit

TMI8262

TMI8262Q

ABSOLUTE MAXIMUM RATINGS (Note 1)

Parameter	Min	Max	Unit
Power supply voltage (VM)	-0.3	45	V
Power supply ramp rate (VMx)		1	V/ μ s
Digital pin voltage	-0.5	7	V
Reference input pin voltage (VREF)	-0.3	4	V
Continuous motor drive output current	0	1.5	A
Operating ambient temperature	-40	85	$^{\circ}$ C
Operating virtual junction temperature	-40	150	$^{\circ}$ C
Storage temperature	-60	150	$^{\circ}$ C

PACKAGE/ORDER INFORMATION

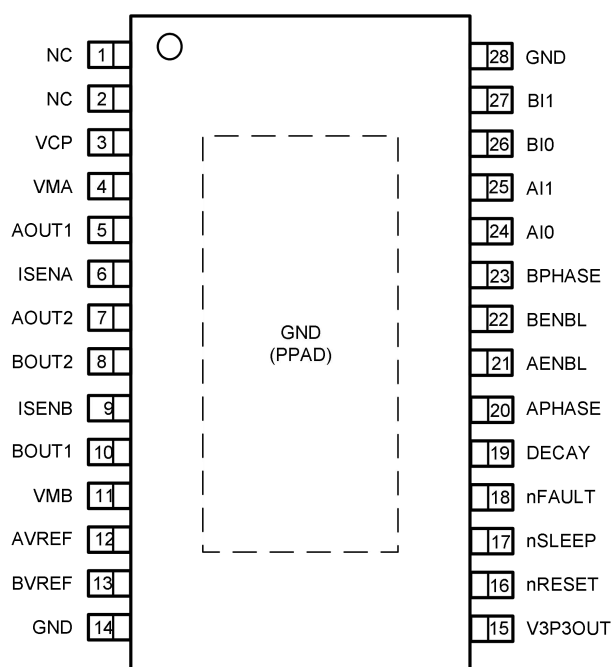

HTSSOP28(Top view)

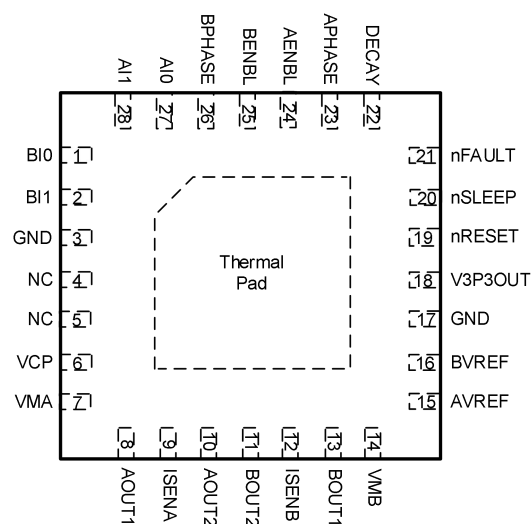

QFN5x5-28(Top view)

TMI8262/XXXXX (TMI8262: Device Code, XXXXX: Inside Code) for TMI8262

TMI8262Q/XXXXX (TMI8262Q: Device Code, XXXXX: Inside Code) for TMI8262Q

Part Number	Package	Top mark	Quantity/ Reel
TMI8262	HTSSOP28	TMI8262 XXXXX	4,500
TMI8262Q	QFN5x5-28	TMI8262Q XXXXX	5,000

The TMI8262 and TMI8262Q devices are Pb-free and RoHS compliant.

PIN FUNCTIONS

Pin			Function
QFN	HTSSOP	Name	
3、17	14、28	GND	Device ground
7	4	VMA	Bridge A power supply, Connect a 0.1 μ F bypass capacitor to ground, as well as a sufficient bulk capacitance rated for VM.
14	11	VMB	Bridge B power supply. Connect a 0.1 μ F bypass capacitor to ground, as well as a sufficient bulk capacitance rated for VM.
18	15	V3P3OUT	3.3V regulator output
4、5	1、2	NC	Not connected.
6	3	VCP	High-side gate drive voltage. Connect a 0.1 μ F ceramic capacitor and 1-M Ω resistor to VM
24	21	AENBL	Bridge A enable. Logic high to enable bridge A
23	20	APHASE	Bridge A phase (direction). Logic high sets AOUT1 high, AOUT2 low
27	24	AI0	Bridge A current set. Sets bridge A current: 00 = 100%, 01 = 71%, 10 = 38%, 11 = 0
28	25	AI1	
25	22	BENBL	Bridge B enable. Logic high to enable bridge B
26	23	BPHASE	Bridge B phase (direction). Logic high sets BOUT1 high, BOUT2 low
1	26	BI0	Bridge B current set. Sets bridge B current: 00 = 100%, 01 = 71%, 10 = 38%, 11 = 0
2	27	BI1	
22	19	DECAY	Decay mode. Low = slow decay, open = mixed decay, high = fast decay
19	16	nRESET	Reset input. Active-low reset input initializes internal logic and disables the H-bridge outputs
20	17	nSLEEP	Sleep mode input. Logic high to enable device, logic low to enter low-power sleep mode
15	12	AVREF	Bridge A current set reference input
16	13	BVREF	Bridge B current set reference input. Reference voltage for winding current set. Can be driven individually with an external DAC for microstepping, or tied to reference input (e.g., V3P3OUT).
21	18	nFAULT	Fault. Logic low when in fault condition (overtemp, overcurrent)
9	6	ISENA	Bridge A ground / Isense. Connect to current sense resistor for bridge B
12	9	ISENB	Bridge B ground / Isense. Connect to current sense resistor for bridge B
8	5	AOUT1	Bridge A output 1

TMI8262

TMI8262Q

PIN FUNCTIONS(Continued)

Pin			Function
QFN	HTSSOP	Name	
10	7	AOUT2	Bridge A output 2
13	10	BOUT1	Bridge B output 1
11	8	BOUT2	Bridge B output 2

ESD RATING

Items	Description	Value	Unit
V _{ESD}	Human Body Model for all pins	±2000	V

JEDEC specification JS-001

RECOMMENDED OPERATING CONDITIONS

Items	Description	Min	Max	Unit
VM	Power supply voltage range	8.2	45	V
VREF	VREF input voltage	1	3.5	V
IV3P3	V3P3OUT load current		10	mA

(1) All VM pins must be connected to the same supply voltage.

(2) Operational at VREF between 0V and 1V, but accuracy is degraded.

ELECTRICAL CHARACTERISTICS

$T_A = 25^\circ\text{C}$, over recommended operating conditions (unless otherwise noted)

PARAMETER	SYMBOL	TEST CONDITIONS	MIN	TYP	MAX	UNIT
POWER SUPPLY						
VM operating supply current	I_{VM}	$VM = 24\text{ V}$, $f_{PWM} < 50\text{ kHz}$		3	5	mA
VM sleep mode supply current	I_{VMQ}	$VM = 24\text{ V}$		0.05	1	μA
VM undervoltage lockout voltage	I_{UVLO}	VM rising		6.5	8	V
V3P3OUT voltage	V_{3P3}	$I_{OUT} = 0\text{ to }1\text{ mA}$, $VM = 24\text{ V}$, $T_J = 25^\circ\text{C}$	3.18	3.30	3.40	V
		$I_{OUT} = 0\text{ to }1\text{ mA}$	3.10	3.30	3.50	V
	$V_{3P3UVLO}$			2		V
LOGIC-LEVEL INPUTS						
Input low voltage	V_{IL}			0.7	0.8	V
Input high voltage	V_{IH}		1.8		5.25	V
Input hysteresis	V_{HYS}			0.45		V
Input low current	I_{IL}	$V_{IN} = 0\text{ V}$	-20		20	μA
Input high current	I_{IH}	$V_{IN} = 3.3\text{ V}$		35	50	μA
nFAULT OUTPUT (OPEN-DRAIN OUTPUT)						
output low voltage	V_{OL}	$I_O = 5\text{ mA}$			0.4	V
output high leakage current	I_{OH}	$V_O = 3.3\text{ V}$			1	μA
DECAY INPUT						
Input low threshold voltage	V_{IL}	For slow decay mode	0		1.2	V
Input high threshold voltage	V_{IH}	For fast decay mode	1.8			V
Input current		Decay=5V			± 45	μA
H-BRIDGE FETS						
HS FET on resistance	$R_{DS(ON)}$	$VM = 24\text{ V}$, $I_O = 1\text{ A}$		0.45		Ω
LS FET on resistance	$R_{DS(ON)}$	$VM = 24\text{ V}$, $I_O = 1\text{ A}$		0.45		Ω
Off-state leakage current	I_{OFF}		-1		1	μA
MOTOR DRIVER						
Internal PWM frequency	f_{PWM}			50		kHz
Current sense blanking time	t_{BLANK}			3.5		μs
Rise time	t_R	$VM = 24\text{ V}$	18		70	ns
Fall time	t_F	$VM = 24\text{ V}$	25		40	ns
Dead time	t_{DEAD}			400		ns
Input deglitch time	t_{DEG}		1.7		2.5	μs

TMI8262

TMI8262Q

ELECTRICAL CHARACTERISTICS (Continued)

$T_A = 25^\circ\text{C}$, over recommended operating conditions (unless otherwise noted)

PARAMETER	SYMBOL	TEST CONDITIONS	MIN	TYP	MAX	UNIT
CURRENT CONTROL						
xVREF input current	I_{REF}	xVREF = 3.3 V	-3		3	μA
xISENSE trip voltage	V_{TRIP}	xVREF = 3.3 V, $I_{SENSE}=0.5\Omega$, 100% current setting	630	660	680	mV
		xVREF = 3.3 V, $I_{SENSE}=0.5\Omega$, 71% current setting	445	468	480	mV
		xVREF = 3.3 V, $I_{SENSE}=0.5\Omega$, 38% current setting	230	251	265	mV
Current sense amplifier gain	A_{ISENSE}	Reference only		5		V/V
PROTECTION CIRCUITS						
Overcurrent protection trip level	I_{OCP}			3		A
Overcurrent deglitch time	t_{OCP}			2.5		μs
Overcurrent retry time	t_{RETRY}			2		ms
Thermal shutdown temperature	T_{SD}		150	170	180	$^\circ\text{C}$

Note 1: Absolute Maximum Ratings are those values beyond which the life of a device may be impaired.

Note 2: T_J is calculated from the ambient temperature T_A and power dissipation P_D according to the following formula: $T_J = T_A + P_D \times \theta_{JA}$. The maximum allowable continuous power dissipation at any ambient temperature is calculated by $P_{D(MAX)} = (T_{J(MAX)} - T_A) / \theta_{JA}$.

Note 3: t_{WAKE} applies when the device initially powers up, and when it exits sleep mode.

Note 4: Thermal shutdown threshold and hysteresis are guaranteed by design.

OPERATION

Overview

The TMI8262 is an integrated motor driver solution for a bipolar stepper motor or two brushed DC motors. The device integrates two NMOS H-bridges, current sense, regulation circuitry, and detailed fault detection. The TMI8262 can be powered with a supply voltage between 8 V and 40 V and is capable of providing an output current up to 1.5 A full-scale.

A PHASE/ENBL interface allows for simple interfacing to the controller circuit. The winding current control allows the external controller to adjust the regulated current that is provided to the motor. The current regulation is highly configurable, with three decay modes of operation. Fast, slow, and mixed decay can be selected depending on the application requirements. A low-power sleep mode is included which allows the system to save power when not driving the motor.

A variety of integrated protection features protect the device in the case of a system fault. These include undervoltage lockout (UVLO), charge pump undervoltage (CPUV), overcurrent protection (OCP), and overtemperature shutdown (TSD). Fault conditions are indicated on the nFAULT pin.

Control Modes

TMI8262 control drive mode is PH/EN control mode. The xPHASE input pin is used to control the direction of current, The xENBL input pins enable the H-bridge outputs when active high. The truth table for PH/EN mode is shown in Table 1.

Table 1. H-Bridge Control Logic

xENBL	xPHASE	xOUT1	xOUT2
0	X	Z	Z
1	0	L	H
1	1	H	L

Current Regulation

In TMI8262, motor peak current can be limited by the analog reference input VREF and the resistance of external sense resistor on the ISEN pin approximately according to the below equation:

$$I_{\text{CHOP}} (\text{A}) = \frac{V_{\text{REF}} (\text{V})}{A_V \times R_{\text{ISEN}} (\Omega)} = \frac{V_{\text{REF}} (\text{V})}{5 \times R_{\text{ISEN}} (\Omega)}$$

For example:

If VREF = 3.3 V and a RISEN = 0.5 Ω, the TMI8262 full-scale (100%) chopping current will be 1.32A;

The two input pins (xI1 and xI0) of each H-bridge are set high and low signals; the current in each bridge is scaled to the corresponding percentage of the full-scale current set by the VREF input pin and the sense resistor. The function of the pin is shown in Table 2.

Table 2. H-Bridge xI0,xI1 Pin Functions

xI1	xI0	RELATIVE CURRENT (% FULL-SCALE CHOPPING CURRENT)
1	1	0%
1	0	38%
0	1	71%
0	0	100%

For example, if $V_{REF} = 3.3\text{ V}$ and a $R_{ISEN} = 0.5\ \Omega$, When the current is set to 100% ($xI1, xI0 = 00$), the chopping current will be 1.32 A; When the current is set to 71% ($xI1, xI0 = 01$), the chopping current will be $1.32\text{ A} \times 71\% = 0.937\text{ A}$; and When the current is set to 38% ($xI1, xI0 = 10$), the chopping current will be $1.32\text{ A} \times 38\% = 0.502\text{ A}$; If ($xI1, xI0 = 11$) the bridge will be disabled and no current will flow.

Decay Mode

During PWM current chopping, the H-bridge is enabled to drive current through the motor winding until the PWM current chopping threshold is reached. This is shown in Figure 2 as case 1. The current flow direction shown indicates the state when the $xENBL$ pin is high.

Once the chopping current threshold is reached, the H-bridge can operate in two different states, fast decay or slow decay.

In fast decay mode, once the PWM chopping current level has been reached, the H-bridge reverses state to allow winding current to flow in a reverse direction. As the winding current approaches zero, the bridge is disabled to prevent any reverse current flow. Fast decay mode is shown in Figure 2 as case 2.

In slow decay mode, winding current is re-circulated by enabling both of the low-side FETs in the bridge. This is shown in Figure 2 as case 3.

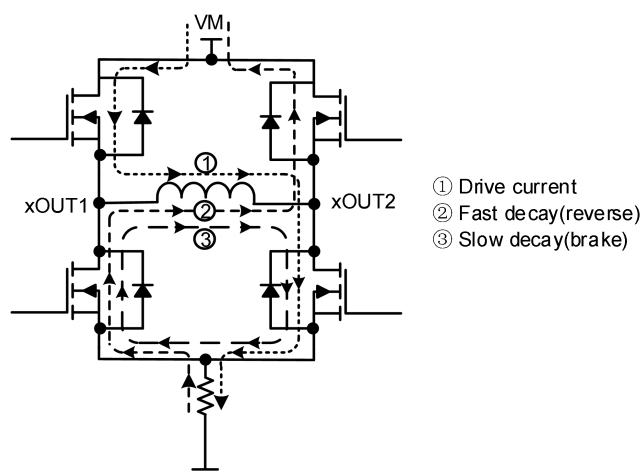

Figure 2. Decay Mode

The TMI8262 supports fast decay, slow decay and a mixed decay mode. Slow, fast, or mixed decay mode is selected by the state of the DECAY pin - logic low selects slow decay, open selects mixed decay operation, and logic high sets fast decay mode. Note that the DECAY pin sets the decay mode for both H-bridges.

Mixed decay mode begins as fast decay, but at a fixed period of time (75% of the PWM cycle) switches to slow decay mode for the remainder of the fixed PWM period.

VM Undervoltage Lockout (UVLO)

If at any time the voltage on the VM pin falls below the undervoltage-lockout threshold voltage, all FETs in the H-bridge will be disabled. Operation resumes when VM rises above the UVLO threshold.

Overcurrent Protection (OCP)

If the output current exceeds the OCP threshold, I_{OCP} , for longer than t_{OCP} , all FETs in the H-bridge are disabled.

As to TMI8262, after a duration of t_{RETRY} , the H-bridge is re-enabled according to the state of the INx pins. If the overcurrent fault is still present, the cycle repeats, otherwise normal device operation resumes.

Thermal Shutdown (TSD)

If the die temperature exceeds safe limits, all FETs in the H-bridge are disabled. After the die temperature has fallen to a safe level, operation automatically resumes.

VM Control

In some systems, varying VM as a means of changing motor speed is desirable.

Application Curves

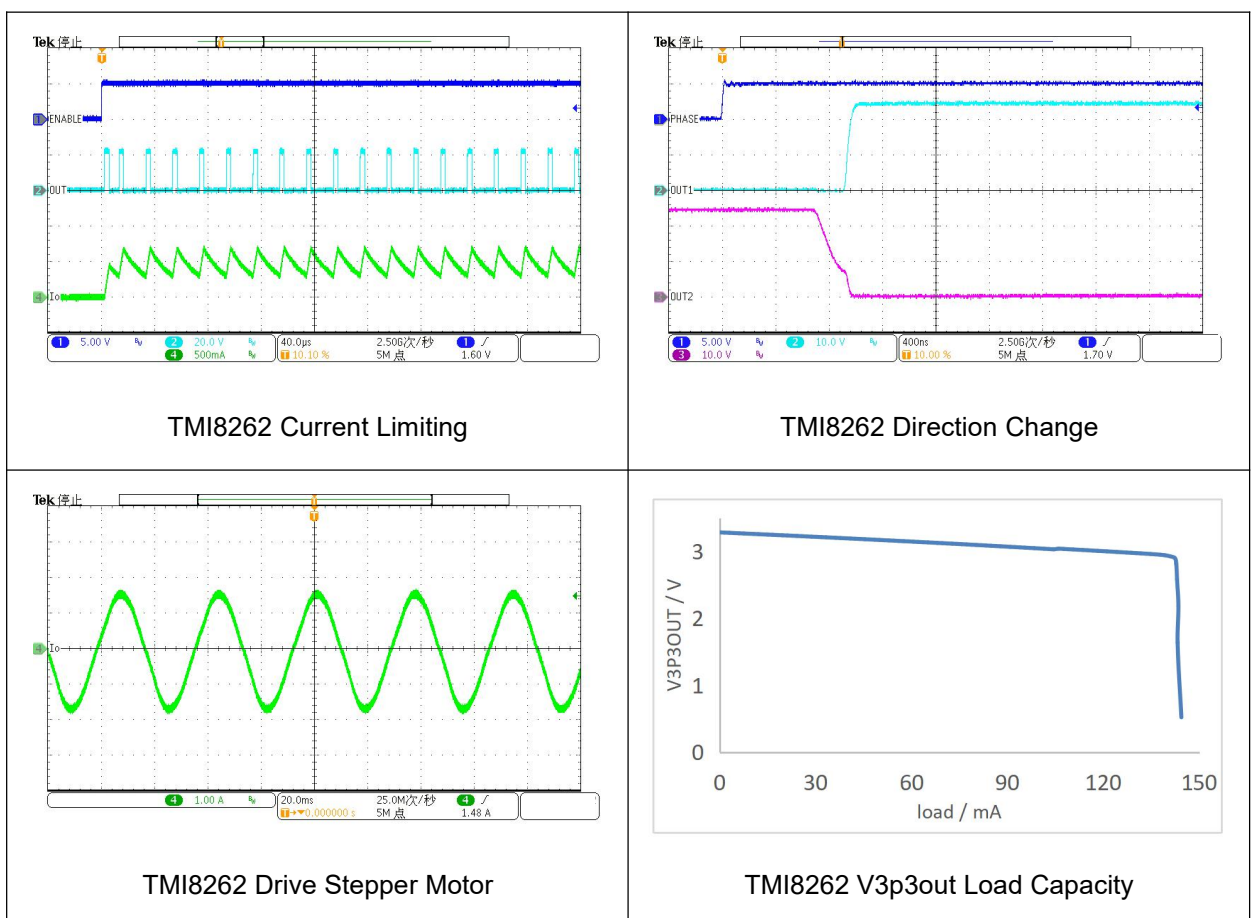

TMI8262

TMI8262Q

APPLICATION INFORMATION

Application information

The TMI8262 can be used to control a bipolar stepper motor. The PHASE/ENBL interface controls the outputs and current control can be implemented with the internal current regulation circuitry. Detailed fault reporting is provided with the internal protection circuits and nFAULT pin.

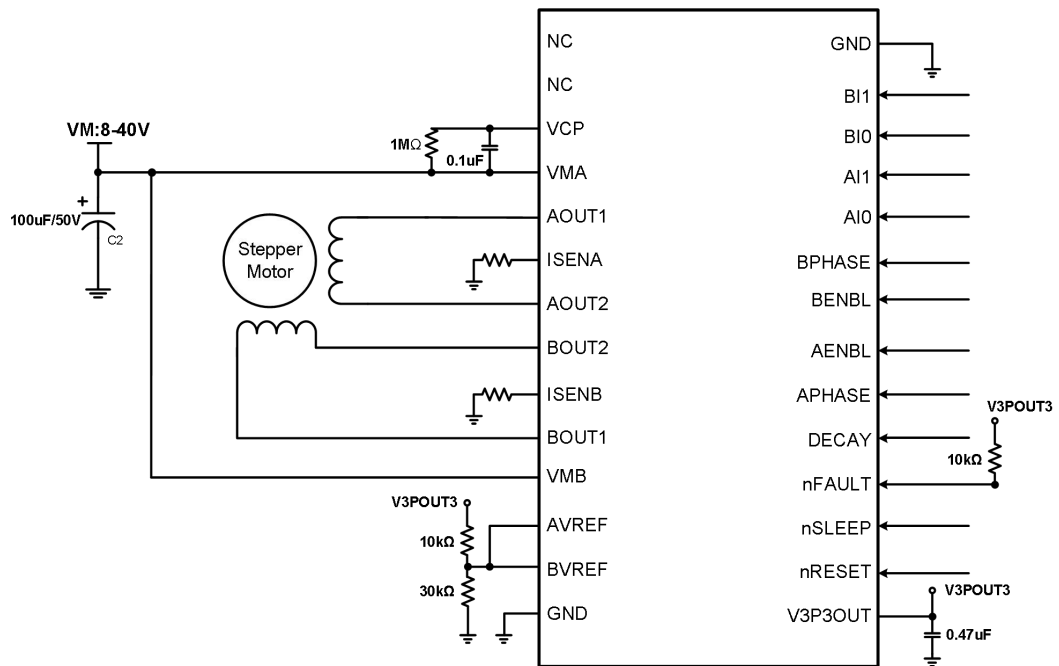

Figure 3. TMI8262_TMI8262Q Typical Application

Block Diagram

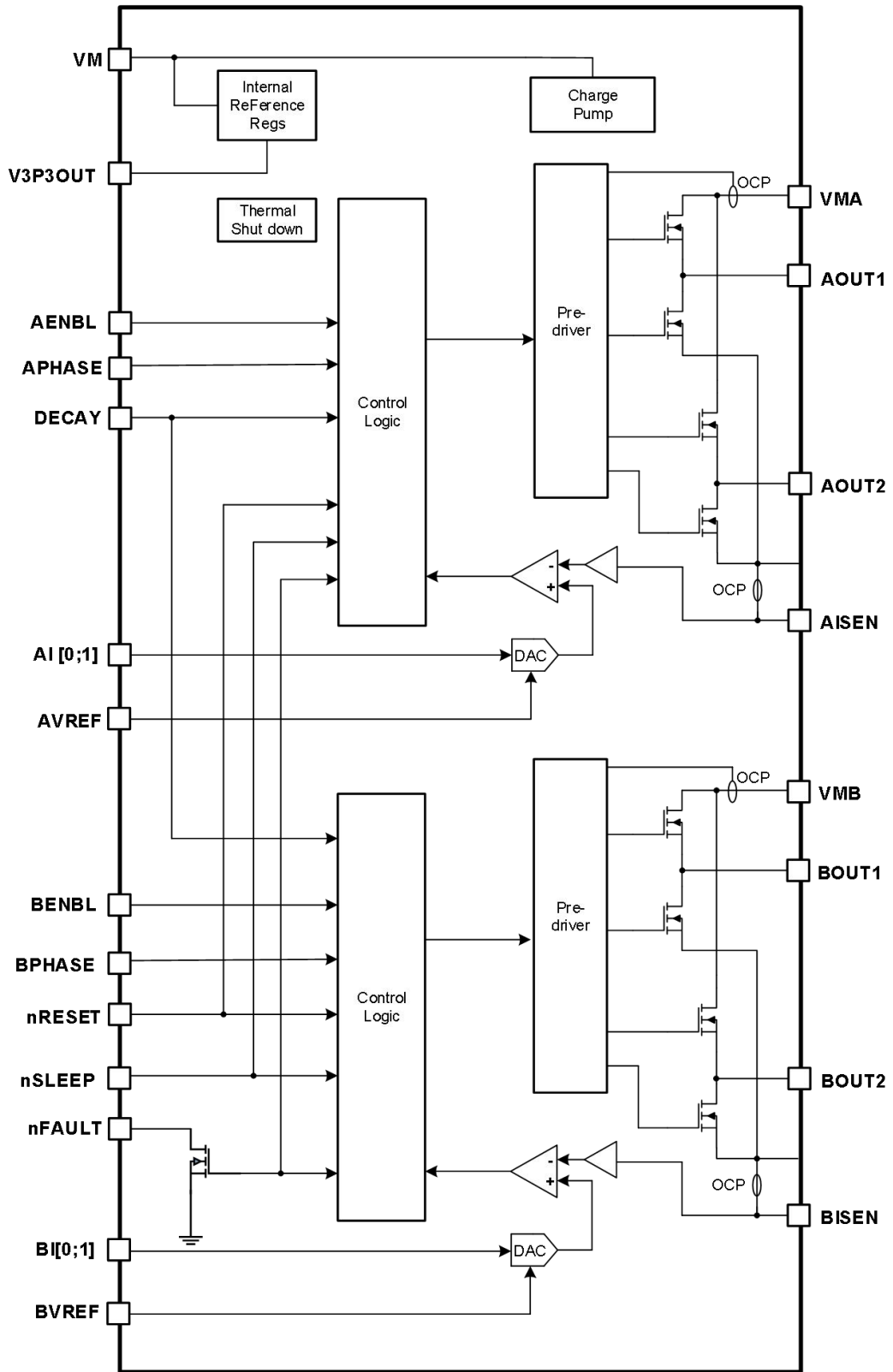

Figure 4. TMI8262_TMI8262Q Block Diagram

TMI8262

TMI8262Q

PACKAGE INFORMATION

HTSSOP28

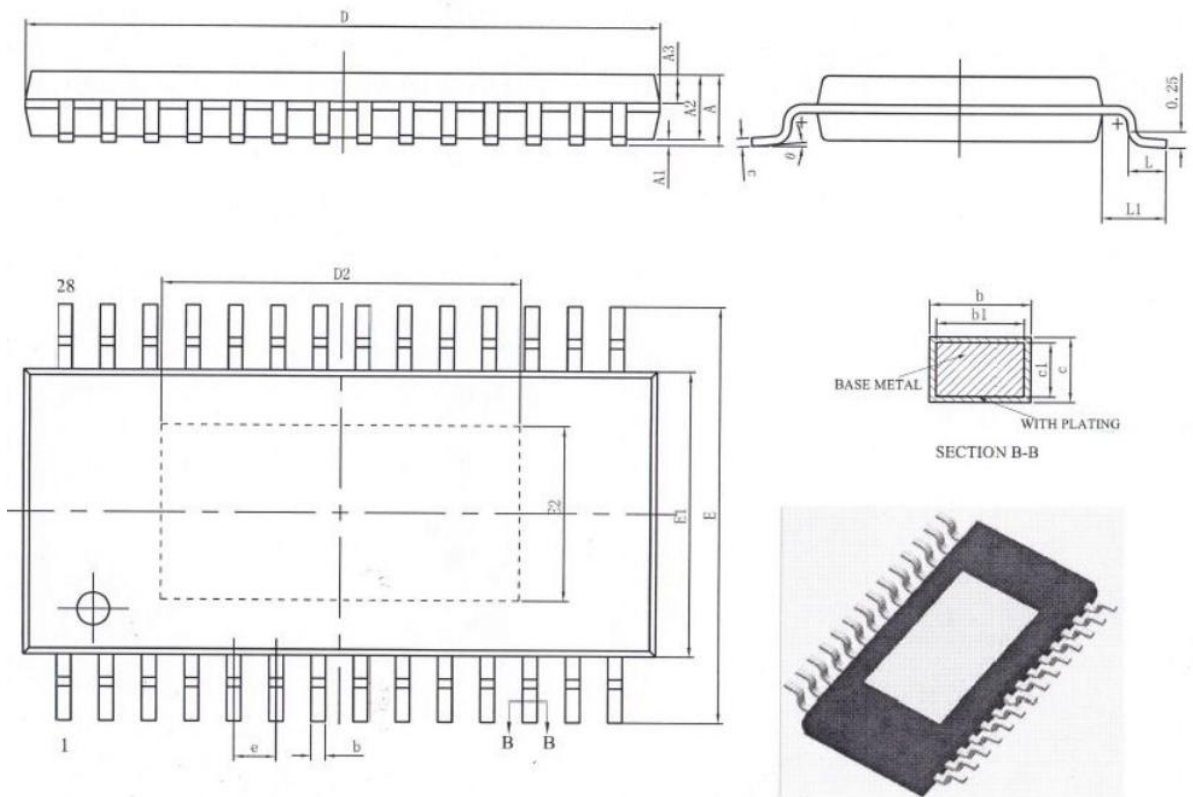

Unit: mm

Symbol	Dimensions In Millimeters			Symbol	Dimensions In Millimeters		
	Min	NOM	Max		Min	NOM	Max
A	-	-	1.20	D	9.60	9.70	9.80
A1	0.05	-	0.15	E	6.20	6.40	6.60
A2	0.80	-	1.00	E1	4.30	4.40	4.50
A2	0.39	0.44	0.49	e	0.65BSC		
b	0.20	-	0.29	L	0.45	0.60	0.75
b1	0.19	0.22	0.25	L1	1.00BSC		
c	0.13	-	0.18	θ	0°	-	8°
c1	0.12	0.13	0.15				

Note:

- 1) All dimensions are in millimeters.
- 2) Package length does not include mold flash, protrusion or gate burr.
- 3) Package width does not include inter lead flash or protrusion.
- 4) Lead popularity (bottom of leads after forming) shall be 0.10 millimeters max.
- 5) Pin 1 is lower left pin when reading top mark from left to right.

PACKAGE INFORMATION

QFN5x5-28

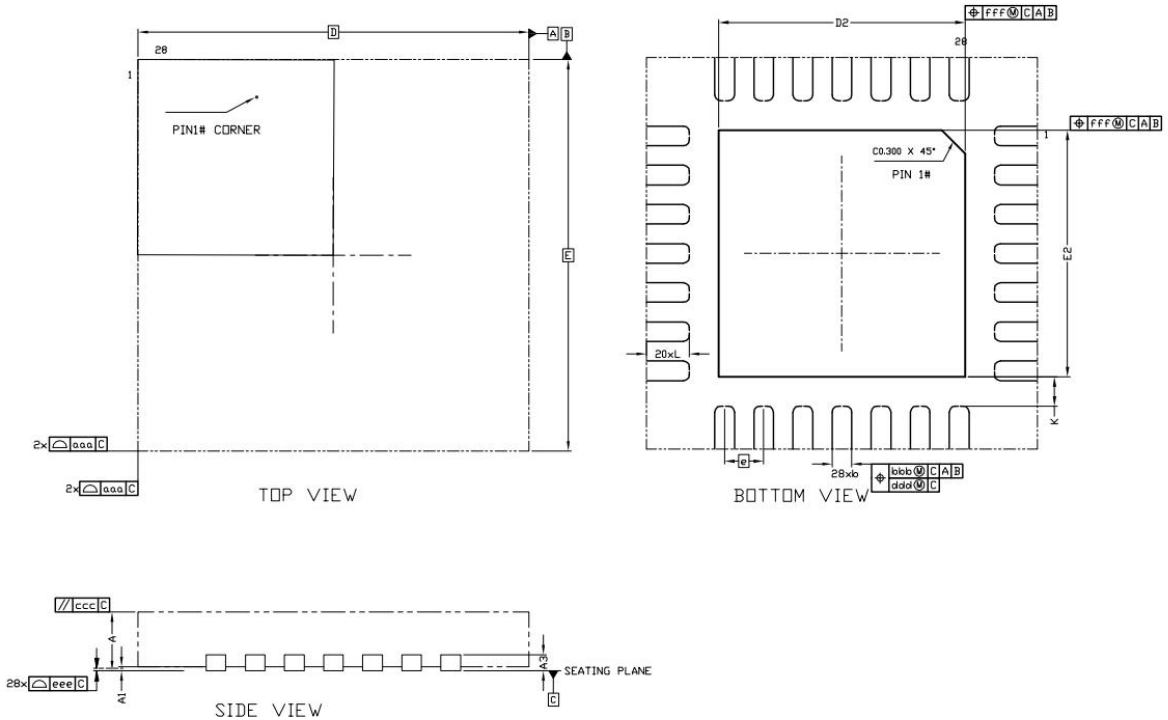

Unit: mm

Symbol	Dimensions In Millimeters			Symbol	Dimensions In Millimeters		
	Min	NOM	Max		Min	NOM	Max
A	0.70	0.75	0.80	e	0.50BSC		
	0.80	0.85	0.90	L	0.50	0.55	0.60
A1	0	0.02	0.05	K	0.20	-	-
A3	-	0.20 REF	-	aaa	0.10		
b	0.18	0.25	0.30	bbb	0.10		
D	5.00BSC			ccc	0.10		
E	5.00BSC			ddd	0.05		
D2	3.05	3.15	3.25	eee	0.08		
E2	3.05	3.15	3.25	fff	0.10		

Note:

- 1) All dimensions are in millimeters.
- 2) Package length does not include mold flash, protrusion or gate burr.
- 3) Package width does not include inter lead flash or protrusion.
- 4) Lead popularity (bottom of leads after forming) shall be 0.10 millimeters max.
- 5) Pin 1 is lower left pin when reading top mark from left to right.

TMI8262

TMI8262Q

TAPE AND REEL INFORMATION

TAPE DIMENSIONS: HTSSOP28

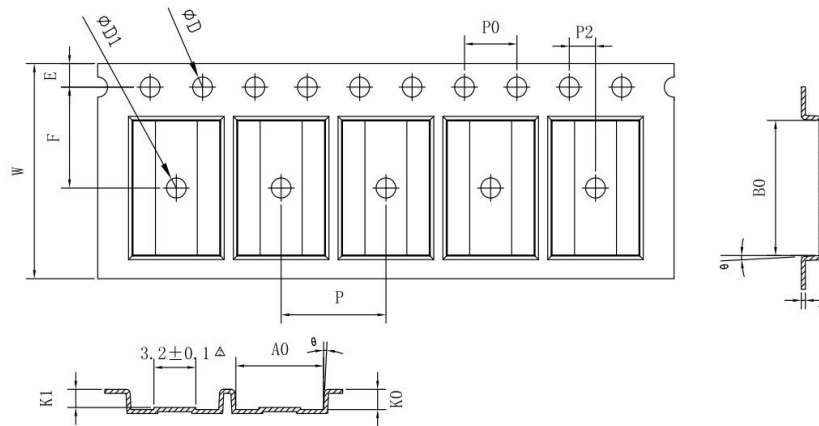

Unit: mm

Symbol	Dimensions	Symbol	Dimensions	Symbol	Dimensions	Symbol	Dimensions
A0	6.70±0.10	θ	5° TYP	E	1.75±0.10	D1	1.55MIN
B0	10.05±0.10	t	0.30±0.05	F	7.50±0.10	P0	0.30±0.10
K0	1.50±0.10	W	16.00±0.30	P2	2.00±0.10	10P0	40.00±0.20
K1	1.35±0.10	P	8.00±0.10	D	1.50±0.10		

REEL DIMENSIONS: HTSSOP28

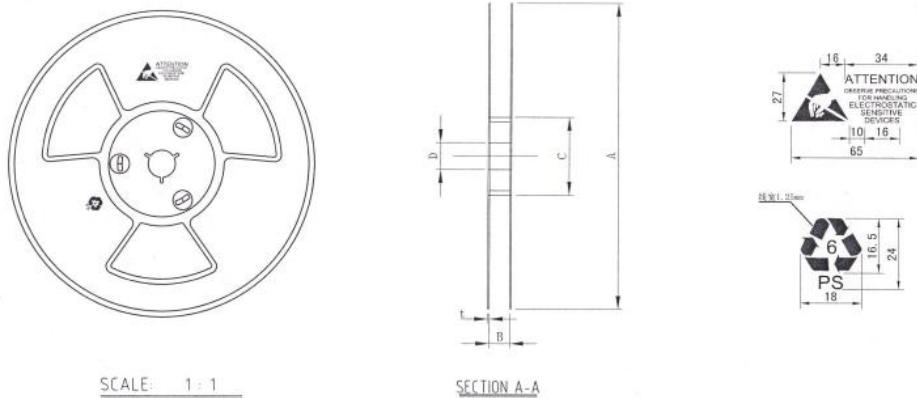

SCALE: 1:1

SECTION A-A

Unit: mm

Ø A	B	Ø C	Ø D	t
329±1.0	16.8±1.0	100±0.5	13.3±0.3	2.0±0.3

Note:

- 1) All Dimensions are in Millimeter
- 2) Quantity of Units per Reel is 4500
- 3) MSL level is level 3.

TAPE AND REEL INFORMATION

TAPE DIMENSIONS: QFN5x5-28

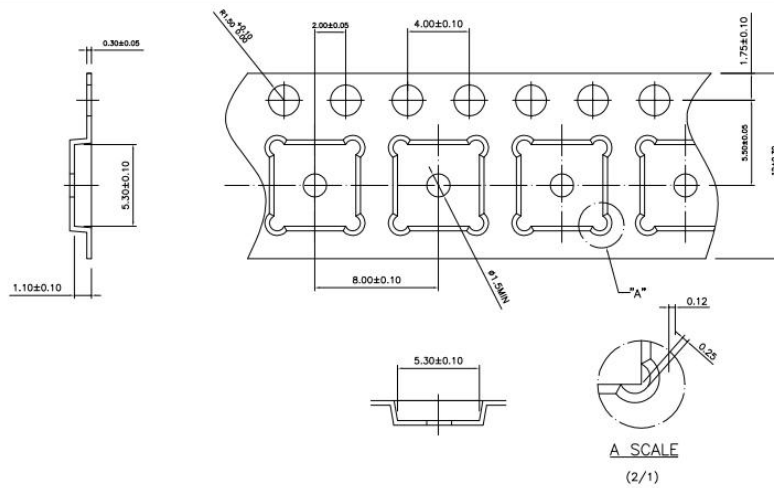

Unit: mm

Symbol	Dimensions	Symbol	Dimensions	Symbol	Dimensions	Symbol	Dimensions
A0	6.70±0.10	θ	5° TYP	E	1.75±0.10	D1	1.55MIN
B0	10.05±0.10	t	0.30±0.05	F	7.50±0.10	P0	0.30±0.10
K0	1.50±0.10	W	16.00±0.30	P2	2.00±0.10	10P0	40.00±0.20
K1	1.35±0.10	P	8.00±0.10	D	1.50±0.10		

REEL DIMENSIONS: QFN5x5-28

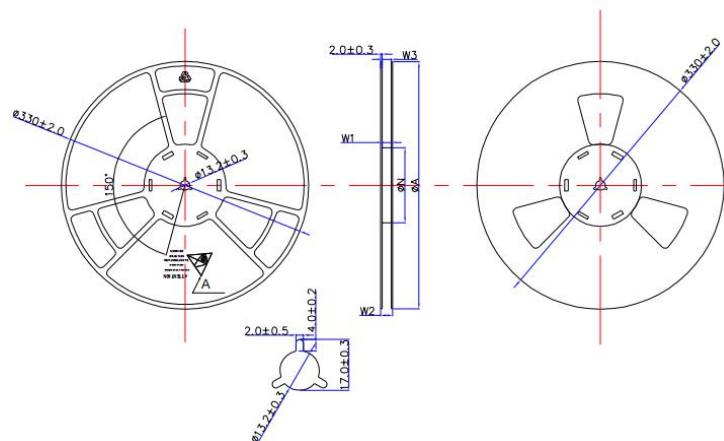

Unit: mm

Ø A	Ø N	W1(+2/0)	W2(Max)	W2(Max)
330±2.0	100±1.0	12.4	18.4	11.9/15.4

Note:

- 1) All Dimensions are in Millimeter
- 2) Quantity of Units per Reel is 5000
- 3) MSL level is level 3.

Important Notification

This document only provides product information. Xi'an TOLL Microelectronic Inc. (TMI reserves the right to make corrections, modifications, enhancements, improvements, and other changes to its products and to discontinue any product without notice at any time.

Xi'an TOLL Microelectronic Inc. (TMI cannot assume responsibility for use of any circuitry other than circuitry entirely embodied in a TMI product. No circuit patent licenses are implied.