

# SPECIFICATIONS

**IEEE 802.11 b/g/n 2.4GHz 1T1R**

Wi-Fi 1T1R Module

**TML1515A-8188FTV**

Version 1.0

**深圳市创凌智联科技有限公司**

公司地址：深圳市宝安区西乡街道水库路中熙 ECO 国际大厦 3 楼

工厂地址：深圳市宝安区沙井锦程路和一永发科技园 4 栋 3 楼

联系方式：0755-88828355/83224500

公司网站：[www.trolink.cn](http://www.trolink.cn)

联系邮箱：[frankai@trolink.cn](mailto:frankai@trolink.cn)

## 1. General Description

This document is to specify the product requirements for 802.11 b/g/n USB Module. This Card is based on Realtek RTL8188FTV chipset that complied with IEEE 802.11g, IEEE 802.11b, IEEE 802.11n standard from 2.4G-2.5GHz, and it can be used to provide up to 54Mbps for 802.11g, 11Mbps for 802.11b and 150Mbps for 802.11n to connect your wireless LAN.

With seamless roaming, fully interoperability and advanced security with WEP standard, 802.11b/g/n USB Module offers absolute interoperability with different vendors 802.11b, 802.11g, 802.11n Access Points through the wireless LAN.

## 2. Features

Compatible with IEEE 802.11b standard to provide wireless 11Mbps data rate.

Compatible with IEEE 802.11g standard to provide wireless 54Mbps data rate.

Compatible with IEEE 802.11n standard to provide wireless 150Mbps data rate.

Operation at 2.4G-2.5GHz frequency band to meet worldwide regulations

Dynamic data rate scaling at 6,9,12,18,24,36,48,54 for IEEE802.11g

Dynamic data rate scaling at 1,2,5.5, and 11Mbps for IEEE802.11b

Maximum reliability, throughput and connectivity with automatic data rate switching

Support wireless data encryption with 64/128-bit WEP for security

Support infrastructure networks via Access Point and ad-hoc network via peer-to-peer communication

Drivers support Windows 2000, XP, Vista

High speed USB 2.0 interface

RoHS compliant.

### 3. Application Diagrams

#### 3.1 Functional Block Diagram

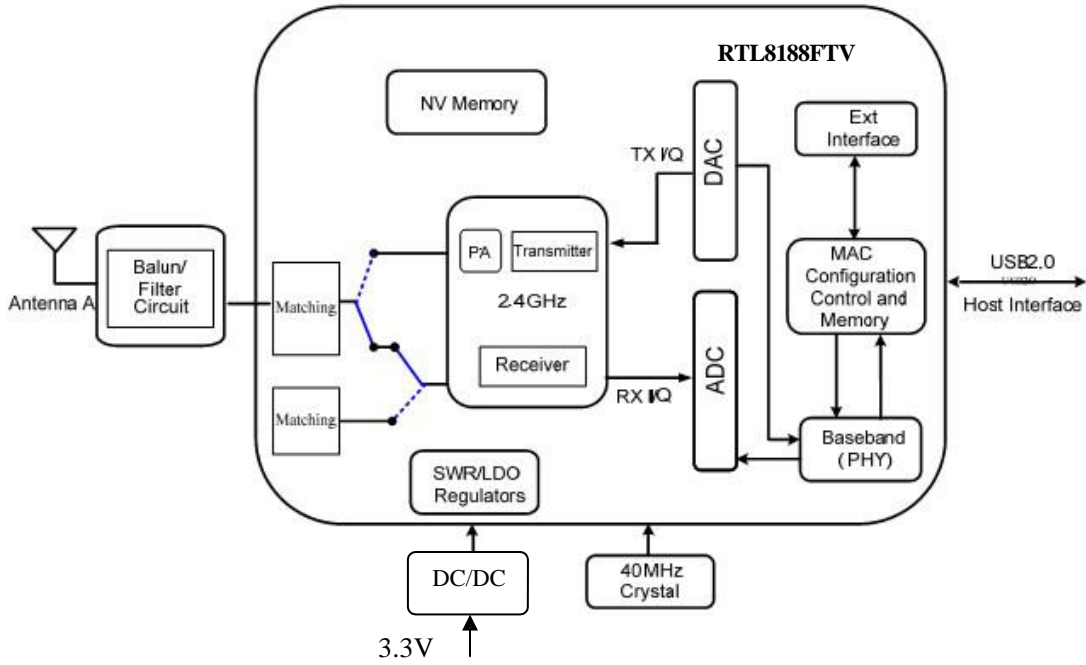

## 3.2 General Requirements

### 3.2.1 IEEE 802.11b Section

	Feature	Detailed Description
3.3.1.1	Standard	<ul style="list-style-type: none"> <li>IEEE 802.11b</li> </ul>
3.3.1.2	Radio and Modulation	<ul style="list-style-type: none"> <li>DQPSK , DBPSK , DSSS , and CCK</li> </ul>
3.3.1.3	Operating Frequency	<ul style="list-style-type: none"> <li>2400 ~ 2497MHz ISM band</li> </ul>
3.3.1.4	Channel Numbers	<ul style="list-style-type: none"> <li>11 channels for United States</li> <li>13 channels for Europe Countries(Default)</li> <li>14 channels for Japan</li> </ul>
3.3.1.5	Data Rate	<ul style="list-style-type: none"> <li>11, 5.5, 2, and 1Mbps</li> </ul>
3.3.1.6	Media Access Protocol	<ul style="list-style-type: none"> <li>CSMA/CA with ACK</li> </ul>
3.3.1.7	Transmitter Output Power at Antenna	<ul style="list-style-type: none"> <li>Typical RF Output Power at each RF chain, Data Rate and at room Temp. 25degree C</li> <li>17±1dBm at 1,2,5.5,11Mbps</li> </ul>
3.3.1.8	Receiver Sensitivity at Antenna Connector	<ul style="list-style-type: none"> <li>Typical Sensitivity at Which Frame(1000-byte PDUs)Error Rate=8%</li> <li>-81dBm at 1Mbps</li> <li>-80dBm at 2Mbps</li> <li>-79dBm at 5.5Mbps</li> <li>-76dBm for 11Mbps</li> </ul>

### 3.3.2 IEEE 802.11g Section

	Feature	Detailed Description
3.3.2.1	Standard	<ul style="list-style-type: none"> <li>IEEE 802.11g</li> </ul>
3.3.2.2	Radio and Modulation Type	<ul style="list-style-type: none"> <li>QPSK , BPSK , 16QAM ,64QAM with OFDM</li> </ul>
3.3.2.3	Operating Frequency	<ul style="list-style-type: none"> <li>2400 ~ 2483.5MHz ISM band</li> </ul>
3.3.2.4	Channel Numbers	<ul style="list-style-type: none"> <li>11 channels for United States</li> <li>13 channels for Europe Countries(Default)</li> <li>13 channels for Japan</li> </ul>
3.3.2.5	Data Rate	<ul style="list-style-type: none"> <li>6,9,12,18,24,36,48,54Mbps</li> </ul>
3.3.2.6	Media Access Protocol	<ul style="list-style-type: none"> <li>CSMA/CA with ACK</li> </ul>
3.3.2.7	Transmitter Output Power at Antenna Connector	<ul style="list-style-type: none"> <li>Typical RF Output Power (tolerance±2dB) at each RF chain, Data Rate and at room Temp. 25degree C</li> <li>16±1dBm at 6~18Mbps</li> <li>15±1dBm at 36 and 24Mbps</li> <li>15±1dBm at 54 and 48Mbps</li> </ul>
3.3.2.8	Receiver Sensitivity at Antenna Connector	<ul style="list-style-type: none"> <li>Typical Sensitivity at Which Frame(1000-byte PDUs)Error rate=10%</li> <li>-87dBm at 6Mbps</li> <li>-86dBm at 9Mbps</li> <li>-84dBm at 12Mbps</li> </ul>

		<ul style="list-style-type: none"> <li>• -82dBm for 18Mbps</li> <li>• -79dBm at 24Mbps</li> <li>• -75dBm at 36Mbps</li> <li>• -71dBm at 48Mbps</li> <li>• -70dBm for 54Mbps</li> </ul>
--	--	--

### 3.3.3 IEEE 802.11n draft 2.0 Section

	Feature	Detailed Description																																																	
3.3.3.1	Standard	<ul style="list-style-type: none"> <li>• IEEE 802.11n</li> </ul>																																																	
3.3.3.3	Radio and Modulation Type	<ul style="list-style-type: none"> <li>• BPSK , QPSK , 16QAM ,64QAM with OFDM</li> </ul>																																																	
3.3.3.3	Operating Frequency	<ul style="list-style-type: none"> <li>• 2400 ~ 2483.5MHz ISM band</li> <li>• Channel Frequency for HT20: 2412~2472MHZ</li> <li>• Channel Frequency for HT40: 2422~2462MHZ</li> </ul>																																																	
3.3.3.4	Data Rate(Mbps)	<ul style="list-style-type: none"> <li>• TX/RX: MCS0 ~MCS7</li> </ul> <table border="1"> <thead> <tr> <th rowspan="2">MCS</th> <th colspan="2">GI=800ns</th> <th colspan="2">GI=400ns</th> </tr> <tr> <th>20MHz</th> <th>40MHz</th> <th>20MHz</th> <th>40MHz</th> </tr> </thead> <tbody> <tr> <td>0</td> <td>6.5</td> <td>13.5</td> <td>7.2</td> <td>15</td> </tr> <tr> <td>1</td> <td>13</td> <td>27</td> <td>14.4</td> <td>30</td> </tr> <tr> <td>2</td> <td>19.5</td> <td>40.5</td> <td>21.7</td> <td>45</td> </tr> <tr> <td>3</td> <td>26</td> <td>54</td> <td>28.9</td> <td>60</td> </tr> <tr> <td>4</td> <td>39</td> <td>81</td> <td>43.3</td> <td>90</td> </tr> <tr> <td>5</td> <td>52</td> <td>108</td> <td>57.8</td> <td>120</td> </tr> <tr> <td>6</td> <td>58.5</td> <td>121.5</td> <td>65.0</td> <td>135</td> </tr> <tr> <td>7</td> <td>65</td> <td>135</td> <td>72.2</td> <td>150</td> </tr> </tbody> </table>	MCS	GI=800ns		GI=400ns		20MHz	40MHz	20MHz	40MHz	0	6.5	13.5	7.2	15	1	13	27	14.4	30	2	19.5	40.5	21.7	45	3	26	54	28.9	60	4	39	81	43.3	90	5	52	108	57.8	120	6	58.5	121.5	65.0	135	7	65	135	72.2	150
		MCS		GI=800ns		GI=400ns																																													
			20MHz	40MHz	20MHz	40MHz																																													
		0	6.5	13.5	7.2	15																																													
		1	13	27	14.4	30																																													
		2	19.5	40.5	21.7	45																																													
		3	26	54	28.9	60																																													
		4	39	81	43.3	90																																													
		5	52	108	57.8	120																																													
6	58.5	121.5	65.0	135																																															
7	65	135	72.2	150																																															
3.3.3.5	Media Access Protocol	<ul style="list-style-type: none"> <li>• CSMA/CA with ACK</li> </ul>																																																	
3.3.3.6	Transmitter Output Power at Antenna Connector	<ul style="list-style-type: none"> <li>• Typical RF Output Power (tolerance±2dB) at each RF chain,Data Rate and at room Temp. 25degree C</li> </ul> <p>HT 20</p> <ul style="list-style-type: none"> <li>• 16±1dBm at MCS 0,1</li> <li>• 16±1dBm at MCS 2,3</li> <li>• 15±1dBm at MCS 4,5</li> <li>• 13±1dBm at MCS 6,7</li> </ul> <p>HT 40</p> <ul style="list-style-type: none"> <li>• 16±1dBm at MCS 0,1</li> <li>• 16±1dBm at MCS 2,3</li> <li>• 15±1dBm at MCS 4,5</li> <li>• 13±1dBm at MCS 6,7</li> </ul>																																																	

3.3.3.7	Receiver Sensitivity at Antenna Connector	<ul style="list-style-type: none"> <li>• Typical Sensitivity at Which Frame(1000-byte PDUs)Error Rate=10%</li> </ul> <p>HT20</p> <ul style="list-style-type: none"> <li>• -81dBm at MCS0</li> <li>• -81dBm at MCS1</li> <li>• -80dBm at MCS2</li> <li>• -77dBm at MCS3</li> <li>• -74dBm at MCS4</li> <li>• -70dBm at MCS5</li> <li>• -68dBm at MCS6</li> <li>• -66dBm at MCS7</li> </ul> <p>HT40</p> <ul style="list-style-type: none"> <li>• -81dBm at MCS0</li> <li>• -79dBm at MCS1</li> <li>• -77dBm at MCS2</li> <li>• -74dBm at MCS3</li> <li>• -71dBm at MCS4</li> <li>• -67dBm at MCS5</li> <li>• -65dBm at MCS6</li> <li>• -63dBm at MCS7</li> </ul>
---------	---	--

## 4. Electrical and Thermal Characteristics

### 4.1 Temperature Limit Ratings

Parameter	Minimum	Maximum	Unit
Storage Temperature	-55	+125	°C
Ambient Operating Temperature	0	70	°C
Junction Temperature	0	125	°C

### 4.2 General Section

	Feature	Detailed Description
4.2.1	Antenna Type	External antenna
4.2.2	Operating Voltage	3.3.V±0.2V
4.2.3	Current Consumption	350mA at continuous transmit mode 220mA at receive mode w/o receiving packet
4.2.4	USB	High Speed USB2.0 Interface

### 4.3 Software

Driver	Windows XP/ WinCE/ Vista,/ Win7, Linux, MAC
Security	64/128-bits WEP, WPA, WPA2

## 4.4 Mechanical Requirements

	Feature	Detailed Description
4.4.1	Length 长度	<ul style="list-style-type: none"> <li>12.70mm</li> </ul>
4.4.2	Width 宽度	<ul style="list-style-type: none"> <li>12.28mm</li> </ul>
4.4.3	Height 高度	<ul style="list-style-type: none"> <li>0.6mm (PCB)</li> </ul>

## 4.5 Mechanical Dimensions

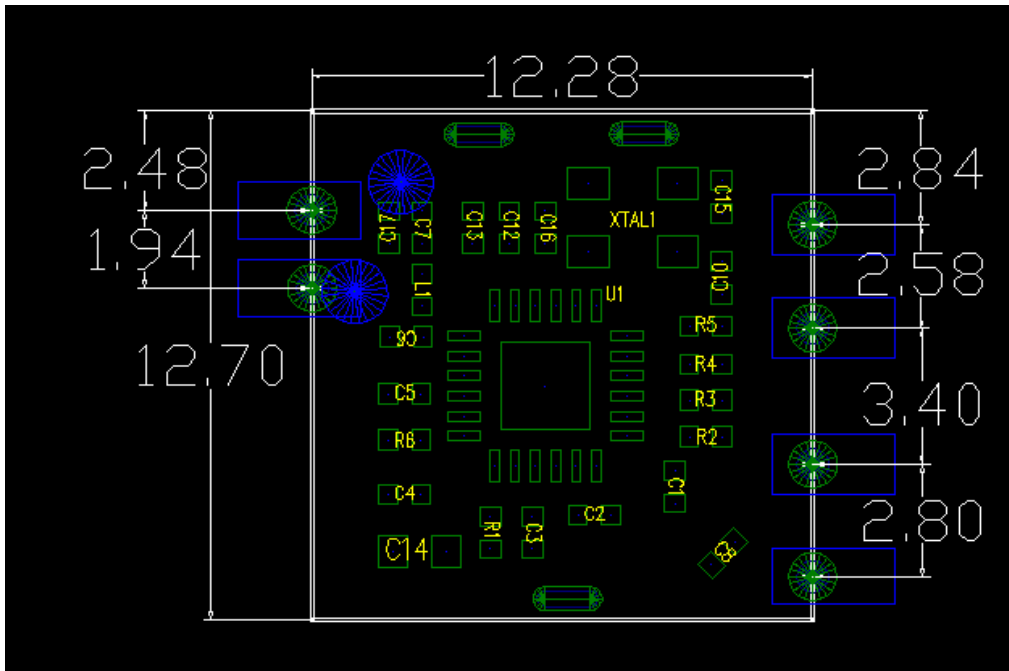

### Product pictures

