



1.5°C ACCURATE DIGITAL TEMPERATURE SENSOR WITH SPI™ INTERFACE

FEATURES

- **Controlled Baseline**
 - One Assembly/Test Site, One Fabrication Site
- **Extended Temperature Performance of -40°C to 125°C**
- **Enhanced Diminishing Manufacturing Sources (DMS) Support**
- **Enhanced Product-Change Notification**
- **Qualification Pedigree ⁽¹⁾**
- **Digital Output: SPI-Compatible Interface**
- **Resolution: 12-Bit + Sign, 0.0625°C**

(1) Component qualification in accordance with JEDEC and industry standards to ensure reliable operation over an extended temperature range. This includes, but is not limited to, Highly Accelerated Stress Test (HAST) or biased 85/85, temperature cycle, autoclave or unbiased HAST, electromigration, bond intermetallic life, and mold compound life. Such qualification testing should not be viewed as justifying use of this component beyond specified performance and environmental limits.

- **Accuracy: $\pm 1.5^\circ\text{C}$ from -25°C to 85°C (max)**
- **Low Quiescent Current: 50 μA (max)**
- **Wide Supply Range: 2.7 V to 5.5 V**
- **Tiny SOT23-6 Package**
- **Operation to 150°C**

APPLICATIONS

- **Power-Supply Temperature Monitoring**
- **Computer Peripheral Thermal Protection**
- **Notebook Computers**
- **Battery Management**
- **Environmental Monitoring**

DESCRIPTION

The TMP121 and TMP123 are SPI-compatible temperature sensors available in the tiny SOT23-6 package. Requiring no external components, the TMP121 and TMP123 are capable of measuring temperatures within 2°C of accuracy over a temperature range of -40°C to 125°C . Low supply current and a supply range from 2.7 V to 5.5 V make the TMP121 and TMP123 excellent candidates for low-power applications.

The TMP121 and TMP123 are ideal for extended thermal measurement in a variety of communication, computer, consumer, environmental, industrial, and instrumentation applications.



Please be aware that an important notice concerning availability, standard warranty, and use in critical applications of Texas Instruments semiconductor products and disclaimers thereto appears at the end of this data sheet.

SPI is a trademark of Texas Instruments.

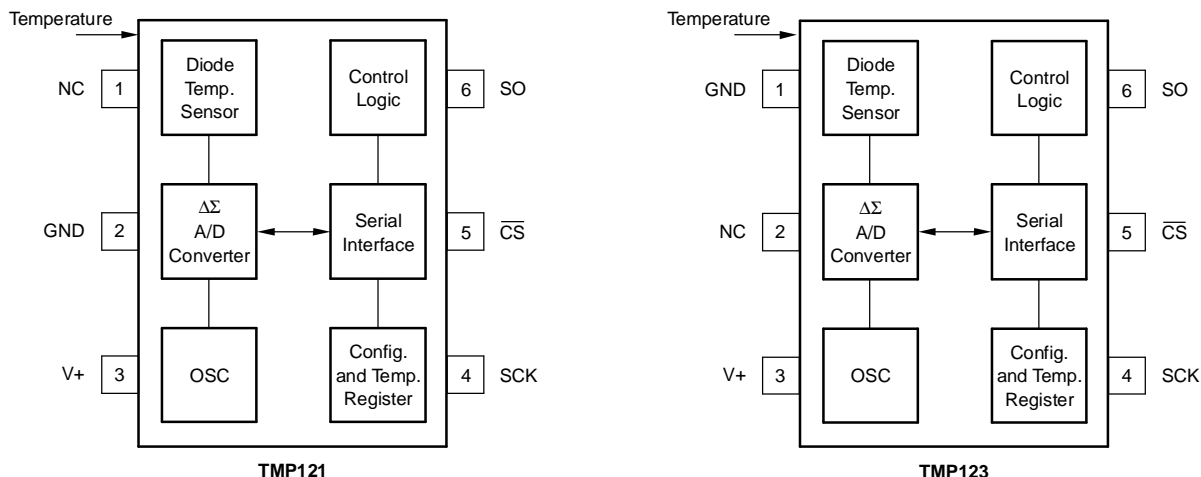

NC = No Connection⁽¹⁾

NC = No Connection⁽¹⁾

(1) Pins Labeled NC should be left floating or connected to GND.

This integrated circuit can be damaged by ESD. Texas Instruments recommends that all integrated circuits be handled with appropriate precautions. Failure to observe proper handling and installation procedures can cause damage.



ESD damage can range from subtle performance degradation to complete device failure. Precision integrated circuits may be more susceptible to damage because very small parametric changes could cause the device not to meet its published specifications.

ORDERING INFORMATION

T _A	PACKAGE-LEAD	ORDERABLE PART NUMBER	PACKAGE MARKING
–40°C to 125°C	SOT23-6 (DBV) Reel of 3000	TMP121AQDBVREP	121E
		TMP123AQDBVREP ⁽¹⁾	123E

(1) Product Preview

ABSOLUTE MAXIMUM RATINGS⁽¹⁾

		UNIT
V+	Power supply	7 V
	Input voltage ⁽²⁾	–0.3 V to 7 V
	Input current	10 mA
	Operating temperature range	–55°C to 150°C
	Storage temperature range	–60°C to 150°C
T _J max	Junction temperature	150°C
	Lead temperature (soldering)	300°C

(1) Stresses above these ratings may cause permanent damage. Exposure to absolute maximum conditions for extended periods may degrade device reliability. These are stress ratings only, and functional operation of the device at these or any other conditions beyond those specified is not supported.

(2) Input voltage rating applies to all TMP121 and TMP123 input voltages.

ELECTRICAL CHARACTERISTICS

At $T_A = -40^\circ\text{C}$ to 125°C and $V_+ = 2.7\text{ V}$ to 5.5 V , unless otherwise noted

PARAMETER	TEST CONDITIONS	MIN	TYP	MAX	UNIT
TEMPERATURE INPUT					
Range		-40		125	$^\circ\text{C}$
Accuracy (temperature error)	-25°C to 85°C		± 0.5	± 1.5	$^\circ\text{C}$
	-40°C to 125°C		± 1	± 2	
	-40°C to 150°C		± 1.5		
Accuracy vs Supply			0.1		$^\circ\text{C}/\text{V}$
Resolution			± 0.0625		$^\circ\text{C}$
DIGITAL INPUT/OUTPUT					
V_{IH}	Input logic levels			0.7(V+)	V
V_{IL}				0.3(V+)	
I_{IN}	Input current, SO, SCK, $\overline{\text{CS}}$	$0\text{ V} \leq V_{IN} \leq V_+$		± 1	μA
V_{OL} SO	Output logic levels	$I_{SINK} = 3\text{ mA}$		0.4	V
V_{OH} SO		$I_{SOURCE} = 2\text{ mA}$		(V+)-0.4	
Resolution			12		Bits
Input capacitance, SO, SCK, $\overline{\text{CS}}$			2.5		pF
Conversion time	12-Bit		240	320	ms
Conversion period ⁽¹⁾	12-Bit		480	640	ms
POWER SUPPLY					
Operating range		2.7		5.5	V
I_Q	Quiescent current	Serial bus inactive	35	50	μA
I_{SD}	Shutdown current (TMP121)	Serial bus inactive	0.1	1	μA
I_{SD}	Shutdown current (TMP123)	Serial bus inactive	0.1	3	μA
TEMPERATURE RANGE					
Specified range		-40		125	$^\circ\text{C}$
Operating range		-55		150	$^\circ\text{C}$
Storage range		-60		150	$^\circ\text{C}$
θ_{JA}	Thermal resistance	SOT23-6 surface-mount		200	$^\circ\text{C}/\text{W}$

(1) Period indicates time between conversion starts.

PIN CONFIGURATIONS

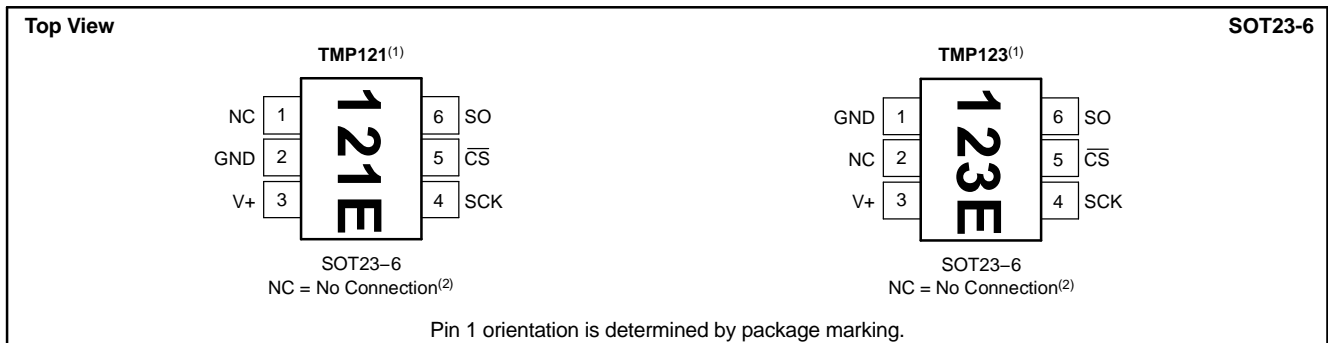

(1) Pin 1 of the SOT23-6 package is determined by orienting the package marking as shown.

(2) Pins labeled NC should be left floating or connected to GND.

TYPICAL CHARACTERISTICS

At $T_A = 25^\circ\text{C}$ and $V_+ = 5\text{ V}$, unless otherwise noted.

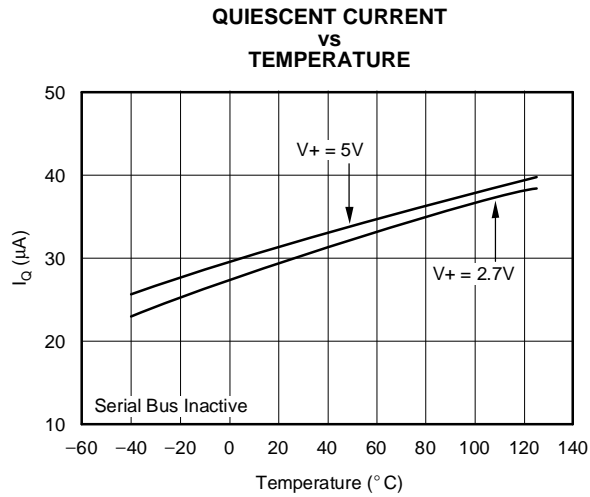

Figure 1.

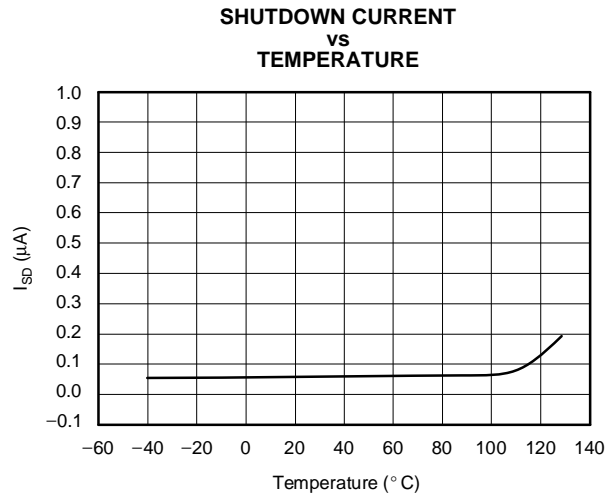

Figure 2.

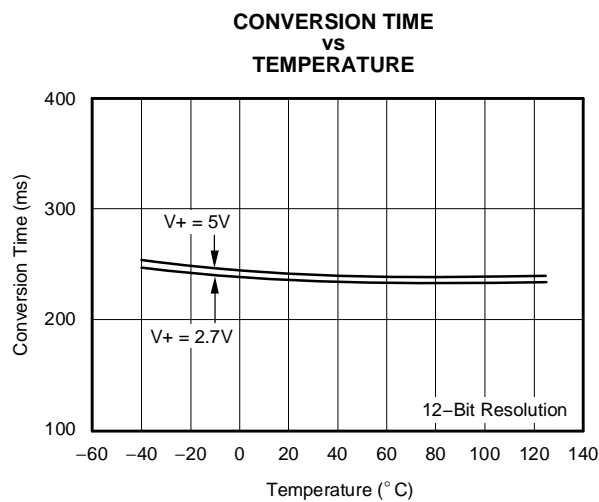

Figure 3.

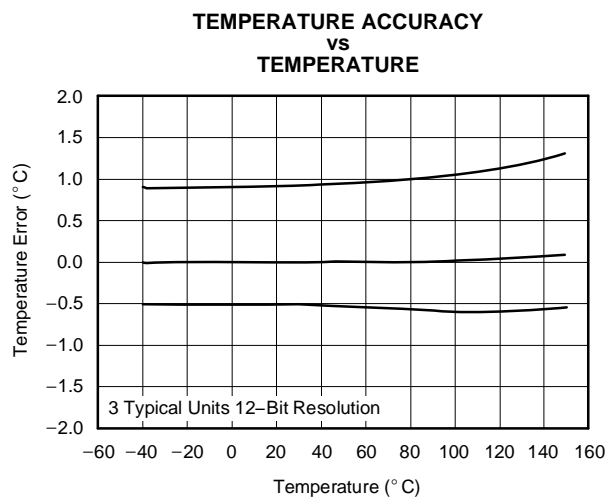

Figure 4.

APPLICATION INFORMATION

The TMP121 and TMP123 are 12-bit plus sign read-only digital temperature sensors optimal for thermal management and thermal protection applications. The TMP121 and the TMP123 communicate through a serial interface that is SPI-compatible. Temperature is converted to a 12-bit plus sign data word with 0.0625°C resolution. The TMP121 and TMP123 are specified for a temperature range of –40°C to 125°C, with operation extending from –55°C to 150°C.

The TMP121 and TMP123 are optimal for low power applications, with a 0.5 s conversion period for reduced power consumption. The TMP121 and TMP123 are specified for a supply voltage range of 2.7 V to 5.5 V, and also feature a hardware shutdown to provide additional power savings.

The TMP121 and TMP123 require no external components for operation, though a 0.1-μF supply bypass capacitor is recommended. Figure 5 shows typical connections for the TMP121 and TMP123.

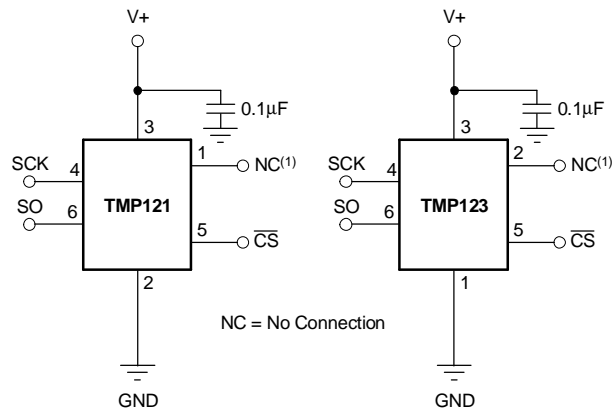

NOTE: Pins labeled NC should be left floating or connected to GND.

Figure 5. Typical Connections of the TMP121 and TMP123

The sensing device of both the TMP121 and TMP123 is the chip itself; the die flag of the lead frame is thermally connected to pin 2 of the TMP121 and of the TMP123. Thermal paths run through the package leads as well as the plastic package, and the lower thermal resistance of metal causes the leads to provide the primary thermal path. The GND pin (pin 2) of the TMP121 and the NC pin (pin 2) of the TMP123 are thermally connected to the metal lead frame and are the best choice for thermal input.

To maintain accuracy in applications requiring air or surface temperature measurement, care should be taken to isolate the package and leads from ambient air temperature.

APPLICATION INFORMATION (continued)

TEMPERATURE REGISTER

The temperature register of the TMP121 and TMP123 is a 16 bit, signed read-only register that stores the output of the most recent conversion. Up to 16 bits can be read to obtain data and are described in [Table 1](#). The first 13 bits are used to indicate temperature with bits D2 = 0 and D1, D0 in a high impedance state. Data format for temperature is summarized in [Table 2](#). Following power-up or reset, the temperature register reads 0°C until the first conversion is complete.

Table 1. Temperature Register

D15	D14	D13	D12	D11	D10	D9	D8	D7	D6	D5	D4	D3	D2	D1	D0
T12	T11	T10	T9	T8	T7	T6	T5	T4	T3	T2	T1	T0	0	Z	Z

Table 2. Temperature Data Format

TEMPERATURE (°C)	DIGITAL OUTPUT ⁽¹⁾ (BINARY)	HEX
150	0100 1011 0000 0000	4B00
125	0011 1110 1000 0000	3E80
25	0000 1100 1000 0000	0C80
0.0625	0000 0000 0000 1000	0008
0	0000 0000 0000 0000	0000
-0.0625	1111 1111 1111 1000	FFF8
-25	1111 0011 1000 0000	F380
-55	1110 0100 1000 0000	E480

(1) The last two bits are high impedance and are shown as 00 in the table.

COMMUNICATING WITH THE TMP121

The TMP121 and TMP123 continuously convert temperatures to digital data while \overline{CS} is high. \overline{CS} must be high for a minimum of one conversion time (320 ms max) to update the temperature data. Reading temperature data from the TMP121 and TMP123 is initiated by pulling \overline{CS} low, which causes any conversion in progress to terminate, and places the device into analog shutdown. Quiescent current is reduced to 1 μ A during analog shutdown. Once \overline{CS} is pulled low, temperature data from the last completed conversion prior to dropping \overline{CS} is latched into the shift register and clocked out at SO on the falling SCK edge. The 16-bit data word is clocked out sign bit first, followed by the MSB. Any portion of the 16-bit word can be read before raising \overline{CS} . The TMP121 and TMP123 typically require 0.25 s to complete a conversion and consume 50 μ A of current during this period. If \overline{CS} is held high for longer than one conversion time period the TMP121 and TMP123 goes into idle mode for 0.25 s, requiring only 20 μ A of current. A new conversion begins every 0.5 s. [Figure 6](#) describes the conversion timing for the TMP121 and TMP123.

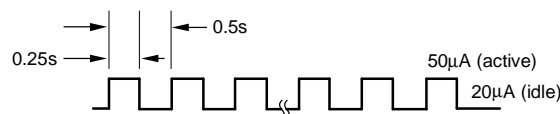

Figure 6. Conversion Time and Period

The serial data of the TMP121 and TMP123 consists of 12-bit plus sign temperature data followed by a confirmation bit and two high impedance bits. Data is transmitted in binary two's complement format. [Figure 7](#) describes the output data of the TMP121 and TMP123.

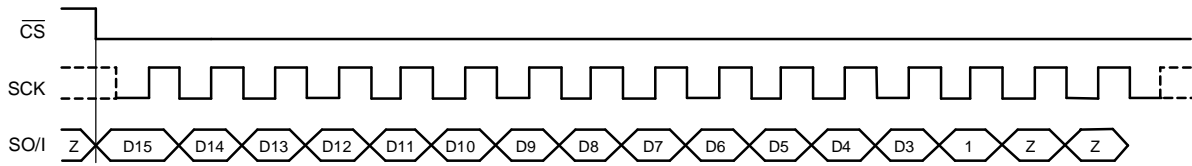

Figure 7. Data READ

Timing Diagrams

The TMP121 and TMP123 are SPI-compatible. [Figure 8](#) and [Figure 9](#) describe the various timing requirements, with parameters defined in [Table 3](#).

Table 3. Timing Description

		MIN	MAX	UNIT
t_1	SCK period	100		ns
t_2	SCK falling edge to output data delay		30	ns
t_3	\overline{CS} to rising edge SCK set-up time	40		ns
t_4	\overline{CS} to output data delay		30	ns
t_5	\overline{CS} rising edge to output high impedance		30	ns

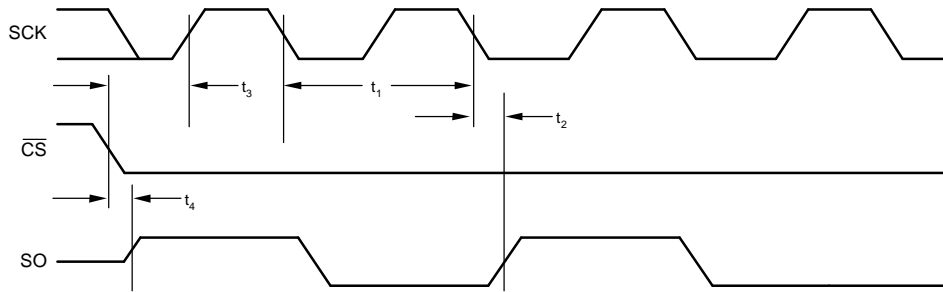

Figure 8. Output Data Timing Diagram

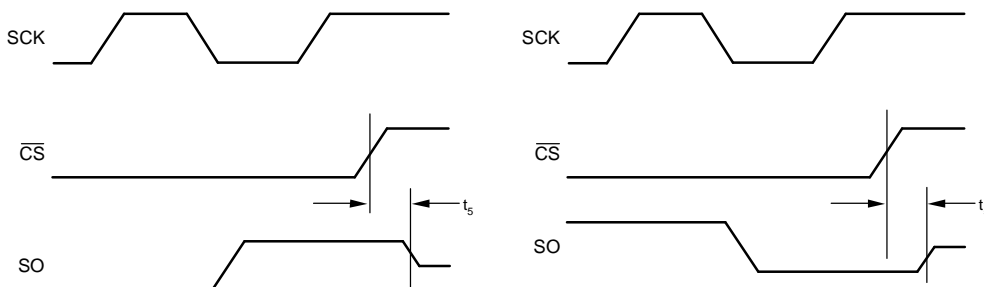

Figure 9. High Impedance Output Timing Diagram

PACKAGING INFORMATION

Orderable Device	Status (1)	Package Type	Package Drawing	Pins	Package Qty	Eco Plan (2)	Lead/Ball Finish (6)	MSL Peak Temp (3)	Op Temp (°C)	Device Marking (4/5)	Samples
TMP121AQDBVREP	ACTIVE	SOT-23	DBV	6	3000	Green (RoHS & no Sb/Br)	CU NIPDAU	Level-2-260C-1 YEAR	-40 to 125	121E	Samples
V62/06608-01XE	ACTIVE	SOT-23	DBV	6	3000	Green (RoHS & no Sb/Br)	CU NIPDAU	Level-2-260C-1 YEAR	-40 to 125	121E	Samples

(1) The marketing status values are defined as follows:

ACTIVE: Product device recommended for new designs.

LIFEBUY: TI has announced that the device will be discontinued, and a lifetime-buy period is in effect.

NRND: Not recommended for new designs. Device is in production to support existing customers, but TI does not recommend using this part in a new design.

PREVIEW: Device has been announced but is not in production. Samples may or may not be available.

OBSELETE: TI has discontinued the production of the device.

(2) Eco Plan - The planned eco-friendly classification: Pb-Free (RoHS), Pb-Free (RoHS Exempt), or Green (RoHS & no Sb/Br) - please check <http://www.ti.com/productcontent> for the latest availability information and additional product content details.

TBD: The Pb-Free/Green conversion plan has not been defined.

Pb-Free (RoHS): TI's terms "Lead-Free" or "Pb-Free" mean semiconductor products that are compatible with the current RoHS requirements for all 6 substances, including the requirement that lead not exceed 0.1% by weight in homogeneous materials. Where designed to be soldered at high temperatures, TI Pb-Free products are suitable for use in specified lead-free processes.

Pb-Free (RoHS Exempt): This component has a RoHS exemption for either 1) lead-based flip-chip solder bumps used between the die and package, or 2) lead-based die adhesive used between the die and leadframe. The component is otherwise considered Pb-Free (RoHS compatible) as defined above.

Green (RoHS & no Sb/Br): TI defines "Green" to mean Pb-Free (RoHS compatible), and free of Bromine (Br) and Antimony (Sb) based flame retardants (Br or Sb do not exceed 0.1% by weight in homogeneous material)

(3) MSL, Peak Temp. - The Moisture Sensitivity Level rating according to the JEDEC industry standard classifications, and peak solder temperature.

(4) There may be additional marking, which relates to the logo, the lot trace code information, or the environmental category on the device.

(5) Multiple Device Markings will be inside parentheses. Only one Device Marking contained in parentheses and separated by a "~" will appear on a device. If a line is indented then it is a continuation of the previous line and the two combined represent the entire Device Marking for that device.

(6) Lead/Ball Finish - Orderable Devices may have multiple material finish options. Finish options are separated by a vertical ruled line. Lead/Ball Finish values may wrap to two lines if the finish value exceeds the maximum column width.

Important Information and Disclaimer: The information provided on this page represents TI's knowledge and belief as of the date that it is provided. TI bases its knowledge and belief on information provided by third parties, and makes no representation or warranty as to the accuracy of such information. Efforts are underway to better integrate information from third parties. TI has taken and continues to take reasonable steps to provide representative and accurate information but may not have conducted destructive testing or chemical analysis on incoming materials and chemicals. TI and TI suppliers consider certain information to be proprietary, and thus CAS numbers and other limited information may not be available for release.

In no event shall TI's liability arising out of such information exceed the total purchase price of the TI part(s) at issue in this document sold by TI to Customer on an annual basis.

OTHER QUALIFIED VERSIONS OF TMP121-EP :

- Catalog: [TMP121](#)

NOTE: Qualified Version Definitions:

- Catalog - TI's standard catalog product

TAPE AND REEL INFORMATION



QUADRANT ASSIGNMENTS FOR PIN 1 ORIENTATION IN TAPE



*All dimensions are nominal

Device	Package Type	Package Drawing	Pins	SPQ	Reel Diameter (mm)	Reel Width W1 (mm)	A0 (mm)	B0 (mm)	K0 (mm)	P1 (mm)	W (mm)	Pin1 Quadrant
TMP121AQDBVREP	SOT-23	DBV	6	3000	180.0	8.4	3.2	3.1	1.39	4.0	8.0	Q3

TAPE AND REEL BOX DIMENSIONS



*All dimensions are nominal

Device	Package Type	Package Drawing	Pins	SPQ	Length (mm)	Width (mm)	Height (mm)
TMP121AQDBVREP	SOT-23	DBV	6	3000	210.0	185.0	35.0

MECHANICAL DATA

DBV (R-PDSO-G6)

PLASTIC SMALL-OUTLINE PACKAGE

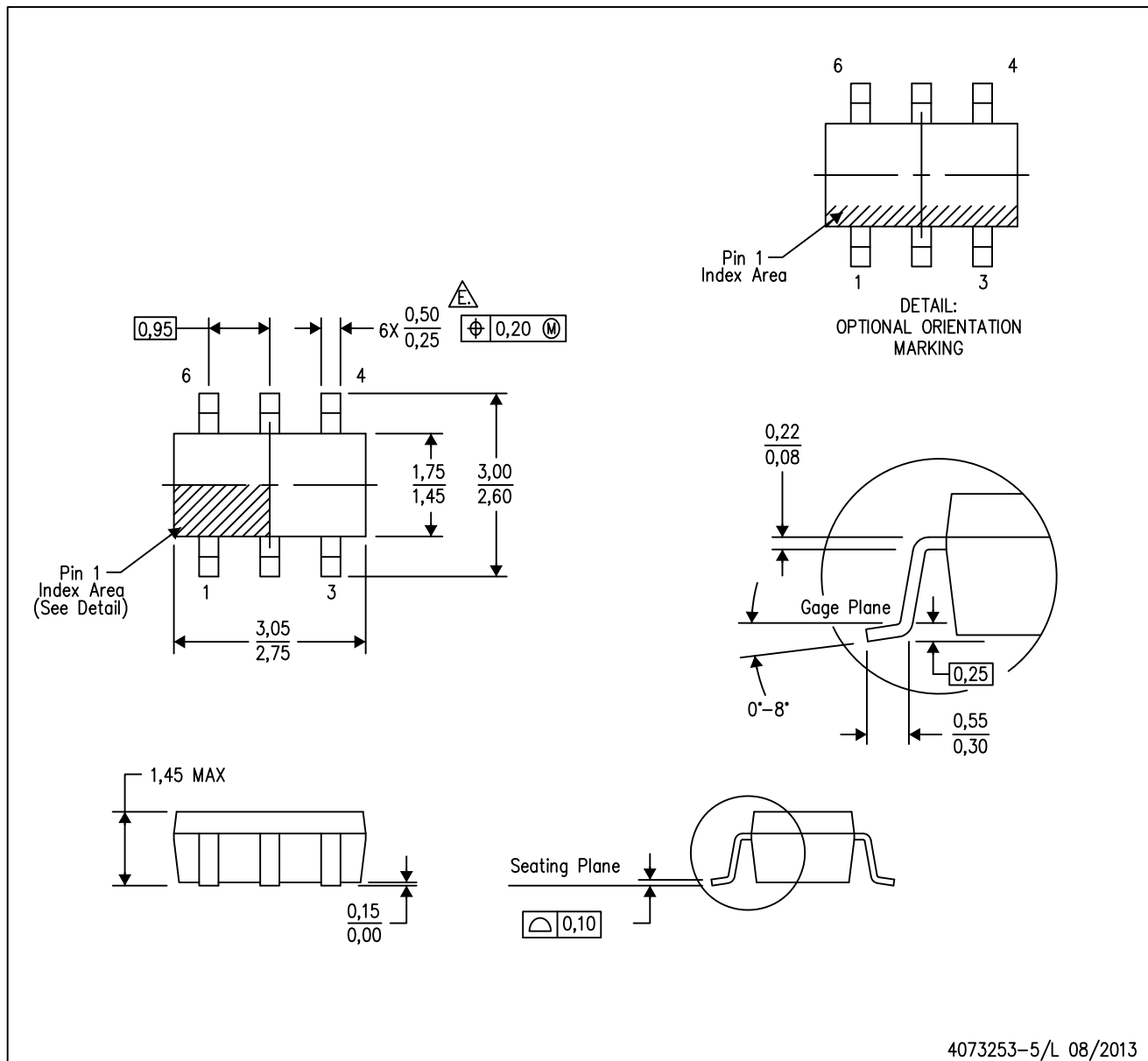

- NOTES:
- All linear dimensions are in millimeters.
 - This drawing is subject to change without notice.
 - Body dimensions do not include mold flash or protrusion. Mold flash and protrusion shall not exceed 0.15 per side.
 - Leads 1,2,3 may be wider than leads 4,5,6 for package orientation.
- ⚠ Falls within JEDEC MO-178 Variation AB, except minimum lead width.

DBV (R-PDSO-G6)

PLASTIC SMALL OUTLINE



- NOTES:
- A. All linear dimensions are in millimeters.
 - B. This drawing is subject to change without notice.
 - C. Customers should place a note on the circuit board fabrication drawing not to alter the center solder mask defined pad.
 - D. Publication IPC-7351 is recommended for alternate designs.
 - E. Laser cutting apertures with trapezoidal walls and also rounding corners will offer better paste release. Customers should contact their board assembly site for stencil design recommendations. Example stencil design based on a 50% volumetric metal load solder paste. Refer to IPC-7525 for other stencil recommendations.

IMPORTANT NOTICE

Texas Instruments Incorporated and its subsidiaries (TI) reserve the right to make corrections, enhancements, improvements and other changes to its semiconductor products and services per JESD46, latest issue, and to discontinue any product or service per JESD48, latest issue. Buyers should obtain the latest relevant information before placing orders and should verify that such information is current and complete. All semiconductor products (also referred to herein as "components") are sold subject to TI's terms and conditions of sale supplied at the time of order acknowledgment.

TI warrants performance of its components to the specifications applicable at the time of sale, in accordance with the warranty in TI's terms and conditions of sale of semiconductor products. Testing and other quality control techniques are used to the extent TI deems necessary to support this warranty. Except where mandated by applicable law, testing of all parameters of each component is not necessarily performed.

TI assumes no liability for applications assistance or the design of Buyers' products. Buyers are responsible for their products and applications using TI components. To minimize the risks associated with Buyers' products and applications, Buyers should provide adequate design and operating safeguards.

TI does not warrant or represent that any license, either express or implied, is granted under any patent right, copyright, mask work right, or other intellectual property right relating to any combination, machine, or process in which TI components or services are used. Information published by TI regarding third-party products or services does not constitute a license to use such products or services or a warranty or endorsement thereof. Use of such information may require a license from a third party under the patents or other intellectual property of the third party, or a license from TI under the patents or other intellectual property of TI.

Reproduction of significant portions of TI information in TI data books or data sheets is permissible only if reproduction is without alteration and is accompanied by all associated warranties, conditions, limitations, and notices. TI is not responsible or liable for such altered documentation. Information of third parties may be subject to additional restrictions.

Resale of TI components or services with statements different from or beyond the parameters stated by TI for that component or service voids all express and any implied warranties for the associated TI component or service and is an unfair and deceptive business practice. TI is not responsible or liable for any such statements.

Buyer acknowledges and agrees that it is solely responsible for compliance with all legal, regulatory and safety-related requirements concerning its products, and any use of TI components in its applications, notwithstanding any applications-related information or support that may be provided by TI. Buyer represents and agrees that it has all the necessary expertise to create and implement safeguards which anticipate dangerous consequences of failures, monitor failures and their consequences, lessen the likelihood of failures that might cause harm and take appropriate remedial actions. Buyer will fully indemnify TI and its representatives against any damages arising out of the use of any TI components in safety-critical applications.

In some cases, TI components may be promoted specifically to facilitate safety-related applications. With such components, TI's goal is to help enable customers to design and create their own end-product solutions that meet applicable functional safety standards and requirements. Nonetheless, such components are subject to these terms.

No TI components are authorized for use in FDA Class III (or similar life-critical medical equipment) unless authorized officers of the parties have executed a special agreement specifically governing such use.

Only those TI components which TI has specifically designated as military grade or "enhanced plastic" are designed and intended for use in military/aerospace applications or environments. Buyer acknowledges and agrees that any military or aerospace use of TI components which have **not** been so designated is solely at the Buyer's risk, and that Buyer is solely responsible for compliance with all legal and regulatory requirements in connection with such use.

TI has specifically designated certain components as meeting ISO/TS16949 requirements, mainly for automotive use. In any case of use of non-designated products, TI will not be responsible for any failure to meet ISO/TS16949.

Products

Audio	www.ti.com/audio
Amplifiers	amplifier.ti.com
Data Converters	dataconverter.ti.com
DLP® Products	www.dlp.com
DSP	dsp.ti.com
Clocks and Timers	www.ti.com/clocks
Interface	interface.ti.com
Logic	logic.ti.com
Power Mgmt	power.ti.com
Microcontrollers	microcontroller.ti.com
RFID	www.ti-rfid.com
OMAP Applications Processors	www.ti.com/omap
Wireless Connectivity	www.ti.com/wirelessconnectivity

Applications

Automotive and Transportation	www.ti.com/automotive
Communications and Telecom	www.ti.com/communications
Computers and Peripherals	www.ti.com/computers
Consumer Electronics	www.ti.com/consumer-apps
Energy and Lighting	www.ti.com/energy
Industrial	www.ti.com/industrial
Medical	www.ti.com/medical
Security	www.ti.com/security
Space, Avionics and Defense	www.ti.com/space-avionics-defense
Video and Imaging	www.ti.com/video

TI E2E Community

e2e.ti.com