

CMOS 4-BIT MICROCONTROLLER

TMP47C236AN, TMP47C336AN

The 47C236A/336A are based on the TLCS-47 CMOS series. The 47C236A/336A have on-screen display circuit (OSD) to display characters and marks which indicate channel or time on TV screen, A/D converter input, D/A converter output which is suitable for application to the digital tuning system such as TV.

PART No.	ROM	RAM	PACKAGE
TMP47C236AN	2048 x 8-bit	128 x 4-bit	30-SDIP
TMP47C336AN	3072 x 8-bit	192 x 4-bit	

FEATURES

- ◆ 4-bit single chip microcomputer
- ◆ Instruction execution time : 1.9 μ s (at 4.2 MHz)
- ◆ 89 basic instructions
 - Table look-up instructions
- ◆ Subroutine nesting : 15 levels max.
- ◆ 6 interrupt sources (External : 2, Internal : 4)
 - All sources have independent latches, and multiple interrupt control is available
- ◆ I/O port (22 pins)
 - Input 2 ports 5 pins
 - I/O 5ports 17 pins
- ◆ Interval Timer
- ◆ Two 12-bit Timer/Counters
 - Timer, event counter, and pulse width measurement mode
- ◆ Display on screen circuit
 - Number of characters 16 kinds
 - Number of characters displayed 3 columns
 - Composition of a character 8 x 8 dots
 - Size of character 2 kinds
 - Color of character 3 kinds
 - Display position Upper right corner
 - Fadeout function
- ◆ Pulse width modulation output
 - 6-bit resolution 1 channels
- ◆ 3-bit A/D converter input
 - Auto frequency control signal (S-shaped curve) detection
- ◆ Horizontal synchronous signal is detected by timer/counter
- ◆ Remote control signal preprocessing capability
- ◆ High current outputs
 - LED direct drive capability (typ. 10mA x 4 bits)
- ◆ HOLD function
 - Battery/Capacitor back-up
- ◆ Real Time Emulator : BM47C336A

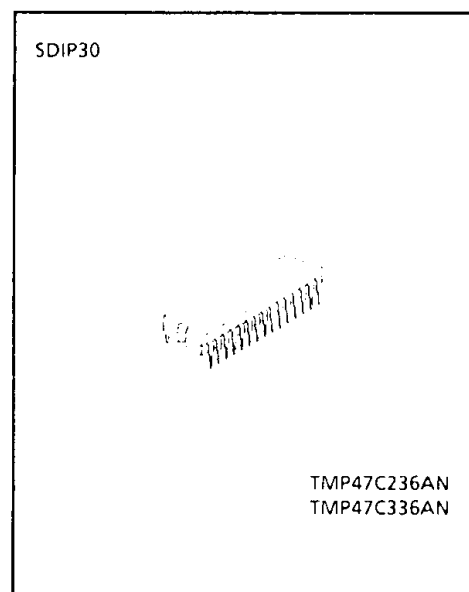

PIN ASSIGNMENT (TOP VIEW)

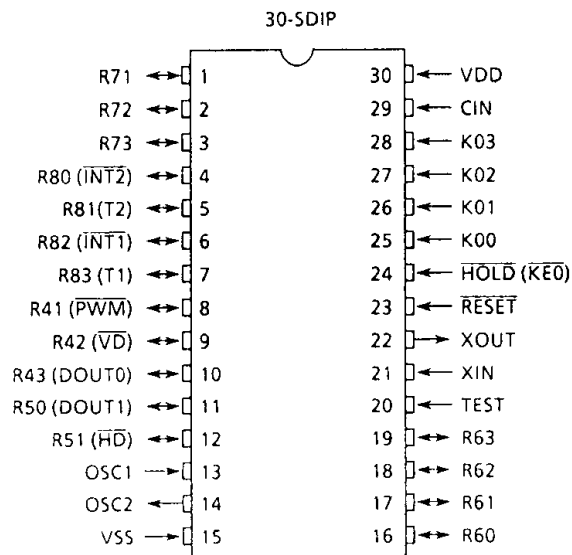

BLOCK DIAGRAM

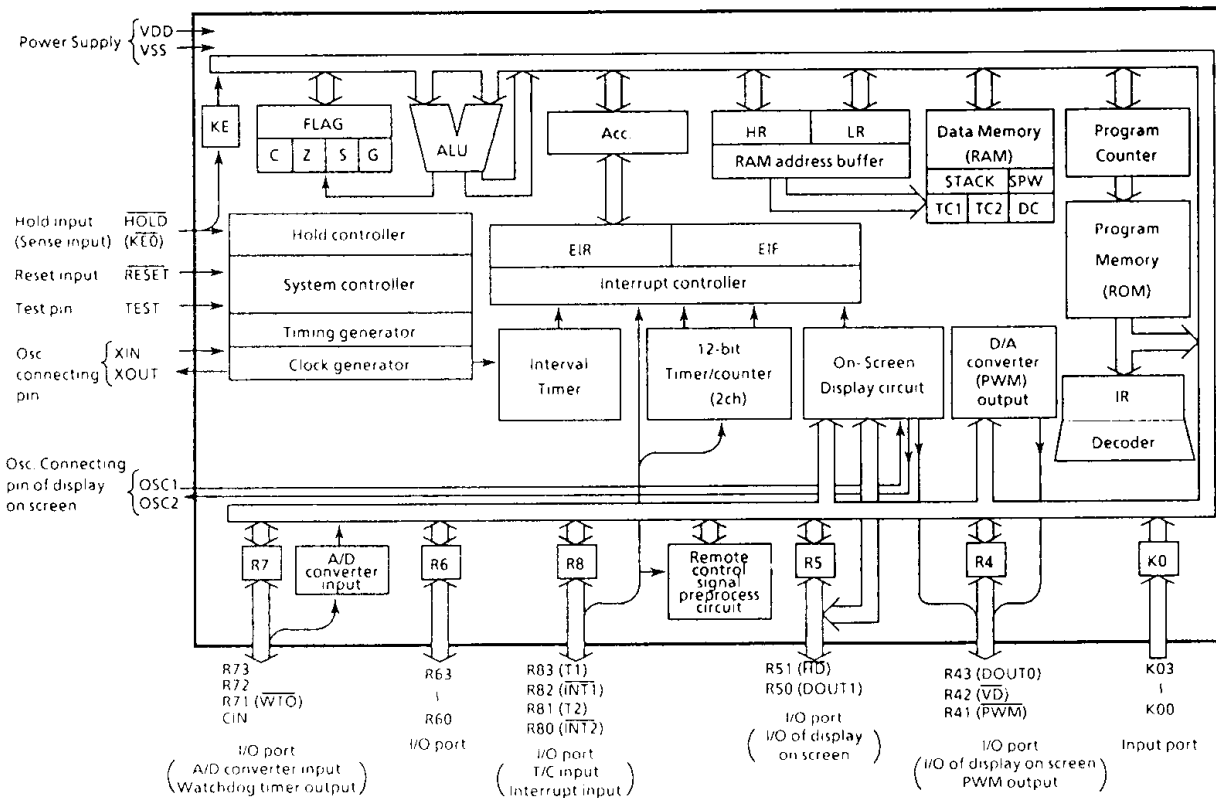

PIN FUNCTION

PIN NAME	Input/Output	FUNCTIONS	
K03 ~ K00	Input	4-bit input port	
R43 (DOUT0)	I/O (Output)	3-bit I/O port with latch. When used as input port, D/A converter output pin and OSD output pin, the latch must be set to "1".	OSD output
R42 ($\bar{V}D$)			Horizontal sync signal input
R41 ($\bar{P}WM$)			6-bit D/A converter output
R51 ($\bar{H}D$)	I/O (Input)	4-bit I/O port with latch. When used as input port, resonator connecting pin for and OSD output pin, the latch must be set to "1".	Horizontal sync signal input
R50 (DOUT1)	I/O (Output)		OSD output
R63 ~ R60	I/O	4-bit I/O port with latch. When used as input port, the latch must be set to "1".	
R73 ~ R71	I/O	3-bit I/O port with latch. When used as input port, the latch must be set to "1".	
R83 (T1)	I/O (Input)	4-bit I/O port with latch. When used as input port, external interrupt and timer/counter input pin, the latch must be set to "1".	Timer/Counter 1 external input
R82 ($\bar{i}NT1$)			External interrupt 1 input
R81 (T2)			Timer/Counter 2 external input
R80 ($\bar{i}NT2$)			External interrupt 2 input
CIN	I/O (Input)	Input pin	3-bit A/D converter input
OSC1, OSC2	Input, Output	Resonator connecting pin of display on screen circuit	
XIN, XOUT	Input, Output	Resonator connecting pin. For inputting external clock, XIN is used and XOUT is opened.	
RESE \bar{T}	Input	Reset signal input	
HOLD ($\bar{K}E0$)	Input (Input)	HOLD request/release signal input	Sense input
TEST	Input	Test pin for out-going test. Be opened or fixed to low level.	
VDD	Power supply	+ 5V	
VSS		0V (GND)	

OPERATIONAL DESCRIPTION

Concerning the 47C236A/336A, the configuration and functions of hardwares are described.

As the description is provided with priority on those parts differing from the 47C200A/400A, the technical data sheets for the 47C200A shall also be referred to.

Note : The 47C236A/336A have no serial port, differing from the 47C200A/400A.

1. SYSTEM CONFIGURATION

(1) Internal CPU Function

Same as 47C200A/400A, except ROM and RAM capacity.

(2) Peripheral Hardware Function

- | | |
|---|---|
| (1) I/O port | (5) A/D converter (comparator) input |
| (2) Interval Timer | (6) D/A converter (Pulse Width Modulation) output |
| (3) Timer/Counter | (7) Remote control signal pre-process circuit |
| (4) On-screen display (OSD) control circuit | |

This section describes functions of (4) to (7) and ROM · RAM capacity.

2. INTERNAL CPU FUNCTION

2.1 Program Memory (ROM)

For the 47C236A, programs are stored to addresses 000-7FF_H (2048 × 8 bits) . And for the 47C336A, programs are stored to addresses 000-BFF_H (3072 × 8 bits). Also, the table look-up instructions [LDH A,@DC +] and [LDL A, @DC] store to the accumulator the permanent data at addresses 000-7FF_H and 000-BFF_H. The 5-bit 8-bit data conversion instruction [OUTB @HL] can not be used.

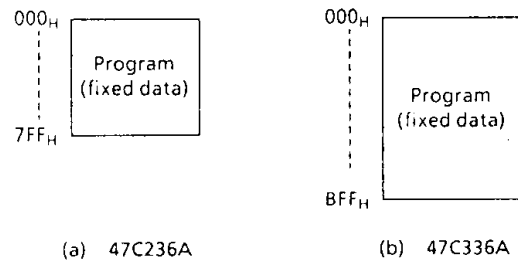

Figure 2-1. Configuration of Program Memory (ROM)

2.2 Data memory (RAM)

TMP47C236A has 128 × 4 bits (address 00_H through 0F_H and 90_H through FF_H) of the data memory (RAM), and the 47C336A has 192 × 4 bits (addresses 00_H through 7F_H and C0_H through FF_H).

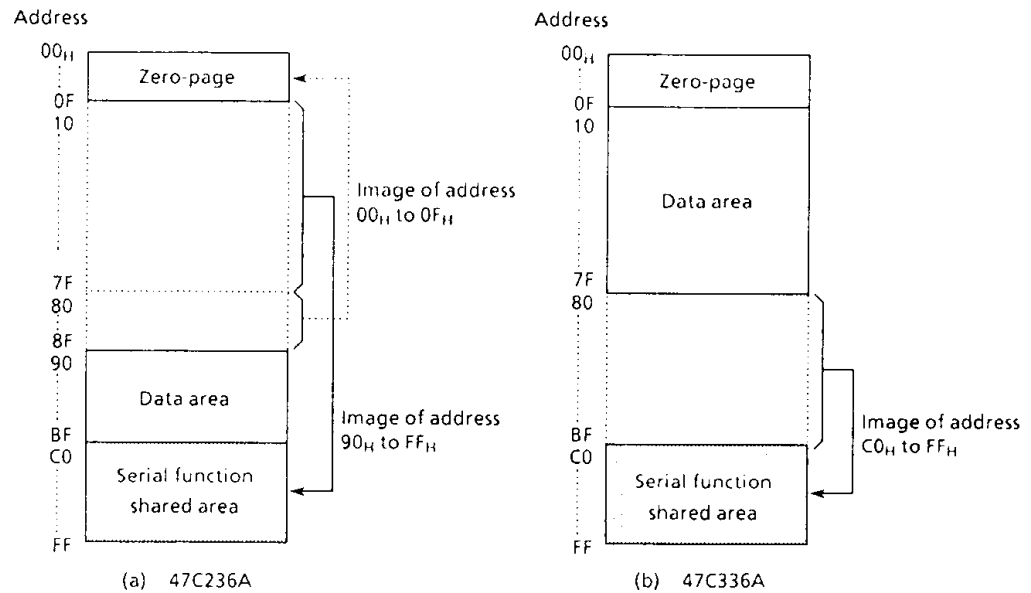

Figure 2-2. Data Memory Capacity and Address Assignment

Note. With the 47C236A, the most significant bit of the RAM address is always regarded as "0", so that addresses 90_H-FF_H may be accessed as addresses 10_H-7F_H. However, programming should be performed assuming that the RAM is assigned to addresses 00_H-0F_H and 90_H-FF_H as shown in Figure 2-2 (a) by considering the application software evaluation with a piggyback or development tools.

And with the 47C336A, the RAM at addresses C0_H-FF_H is accessed when addresses 80_H-BF_H are addressed by a program, but when creating programs for evaluating software for piggybacks or development tools, assign the data memory to addresses 00_H-7F_H or to addresses C0_H-FF_H, same as the 47C236A.

3. PERIPHERAL HARDWARE FUNCTION

3.1 I/O ports

The 47C236A/336A has 7 I/O Ports (24 Pins) each as follow.

- ① K0 port ; 4-bit input
- ② R4 port ; 3-bit input/output (R42 pin is shared by OSD output. R41, R42 pins is shared by D/A converter output)
- ③ R5 port ; 4-bit input/output (R53, R52 pins is shared by Resonator connecting pin for OSD R51, R50 pins is shared by I/O port)
- ④ R6 port ; 4-bit input/output
- ⑤ R7 port ; 4-bit input/output (R70 pins is shared by AFC comparator input)
- ⑥ R8 port ; 4-bit input/output (shared by external interrupt input and timer/counter input)
- ⑦ KE port ; 1-bit sense input (shared by hold request/release signal input)

This section describes ports of ②, ③, ⑤ which are changed from the 47C200A / 400A.

The 47C236A/336A has no P1, P2 and R9, therefore 5-bit 8-bit data conversion instruction [OUTB @HL] can not use.

Table 3-1 lists the port address assignments and the I/O instructions that can access the ports.

(1) Port R4 (R43-R41)

3-bit I/O port with latch. When used as input port, the latch must be set to "1". The latch is initialized to "1".

This pin is used both as R43 for OSD output, and as R41 and R42 for D/A converter output. When used for OSD output, select DOUT0 to enable OSD. To use for D/A converter, set the latch to "1".

Also, when this pin is used as R43 for OSD output, "1" is read at the R43 pin and the \overline{VD} is read at the R42 pin, during the input instruction is executed. There is no R40 pin, but "1" is read in during the input instruction is executed.

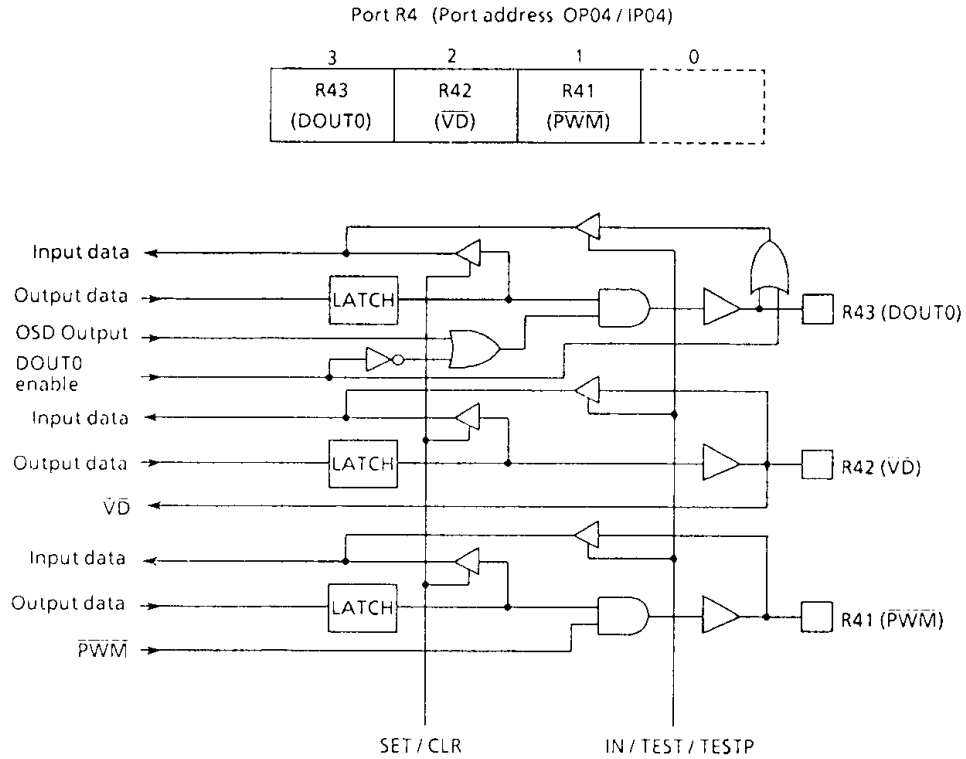

Figure 3-1. Port R4

(2) Port R5 (R51-R50)

This is a 2-bit input/output port with latch. When used as an input port, set the latch to "1". The R50 pin is used to disable OSD display. The latch is initialized to "1" by resetting.

The R51 pin is also used as the HD (horizontal sync signal) input pin. When used as the \overline{HD} input pin, set the latch to "1". Like the R43 pin, the R50 pin is also used as the OSD output pin. When an input instruction is executed with OSD display enabled, "1" is read at the R50 pin and VD is read at the R51 pin. There are no R53 or R52 pins but "1" is read when an input instruction is executed.

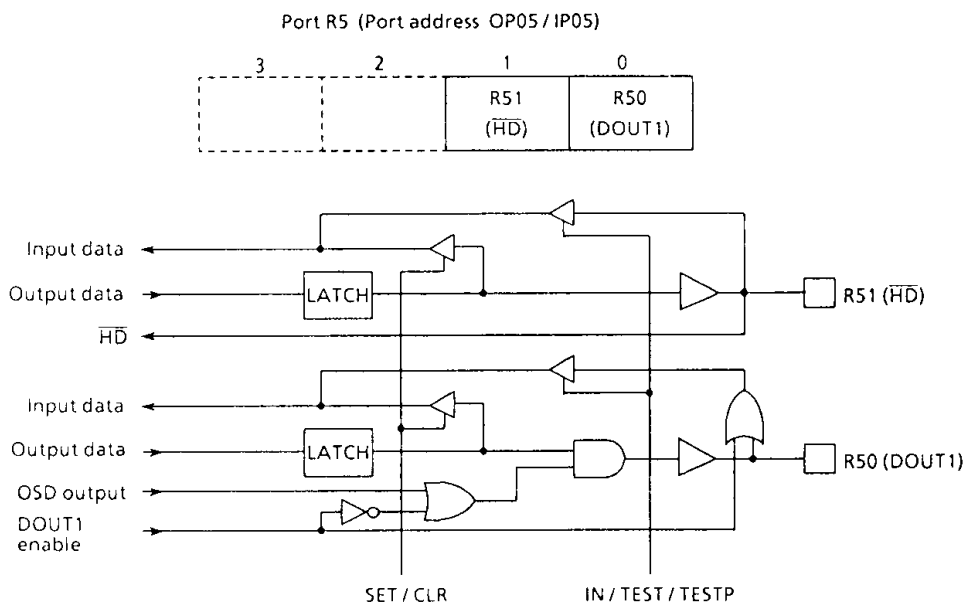

Figure 3-2. Port R5

(3) Port R7 (R73-R71) and CIN pin

Port R7 is 3-bit I/O ports with latch. When used as an input port, the latch should be set to "1". The latch is initialized to "1" during reset.

CIN pin is the A/D converter (comparator) input for the detection of AFC (Auto Frequency Control) signal. When used a comparator, the bit-3 of command register (OP12) is set to "1". CIN is the comparator input which has a programmable 3-bit D/A converter as a reference voltage source, and its data is read in the bit-0 of IP07.

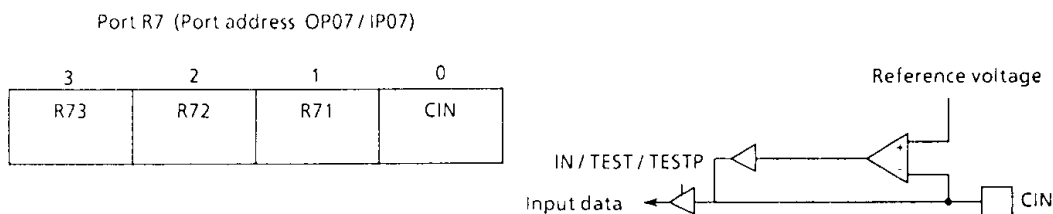

Figure 3-3. Port R7

3.2 On-Screen Display (OSD) Circuit

This built-in on-screen display circuit displays characters and symbols on the TV screen. Display size is 3 columns x 1 line, with a choice of 16 character patterns. Fadeout is also possible when the display is turned off.

3.2.1 OSD Circuit Function

- | | |
|----------------------------------|-------------------------------------|
| ① Number of characters | 16 kinds |
| ② Number of characters displayed | 3 characters |
| ③ Composition of a character | 8 x 8 dots |
| ④ Size of character | 2 kinds |
| ⑤ Color of character | 3 kinds |
| ⑥ Display position variable | upper right corner of the TV screen |
| ⑦ Fadeout function | |

3.2.2 OSD Circuit Configuration

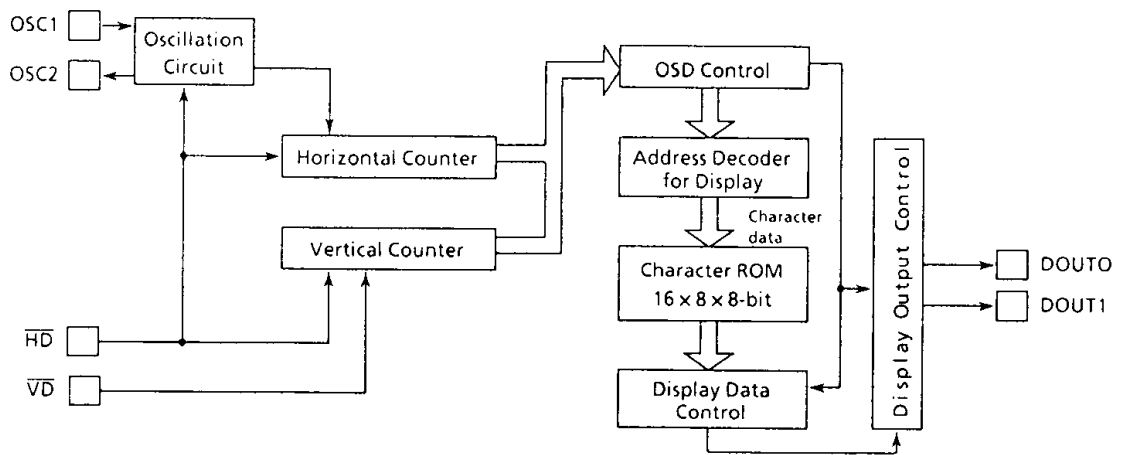

Figure 3-4. OSD Circuit

3.2.3 Character Display and Data Table for Display

The 16 character types are stored in the character ROM and the user can set optional patterns as shown in Figure 3-7. The character ROM contains 16 characters (character codes 00-0FH) with an 8 x 8 dot configuration. Each character bit corresponds to one bit in the character ROM. "1" turns on the bit (dot) and "0" turns off the bit (dot).

When submitting programs, place the character data at address 1000H and following (addresses 1000-107FH). Figure 3-5 shows typical character (8 x 8 bits) addresses and data. Figure 3-6 shows the standard pattern hex list.

Address	Data
010 _H	78 _H
011	84
012	04
013	08
014	10
015	20
016	40
017	FC

Figure 3-5. Example of Character

Address	000 _H	78	84	84	84	84	84	84	78	10	30	10	10	10	10	38
010	78	84	04	08	10	20	40	FC	78	84	04	18	04	04	84	78
020	18	28	48	88	88	FC	08	08	FC	80	80	F8	04	04	84	78
030	78	84	80	F8	84	84	84	78	FC	04	04	08	10	20	20	20
040	78	84	84	78	84	84	84	78	78	84	84	7C	04	04	84	78
050	10	28	44	82	FE	82	82	82	82	82	82	82	82	44	28	10
060	02	04	08	10	10	20	40	80	7C	82	40	38	04	02	82	7C
070	FC	82	82	FC	80	80	80	80	00	00	00	00	00	00	00	00

Figure 3-6. Example Character Data (address 2000_H~)

Note: Each character has an 8-byte data area. The starting address is the value of the character ROM address (00-0F_H) contained by the upper 4 bits of the 7-bit program area (00-7F_H).

3.2.7 Character ROM (Example Character)

The character data consist of the characters and symbols shown in Figure 3-7 as Example patterns. Optional character patterns can also be set by the user.

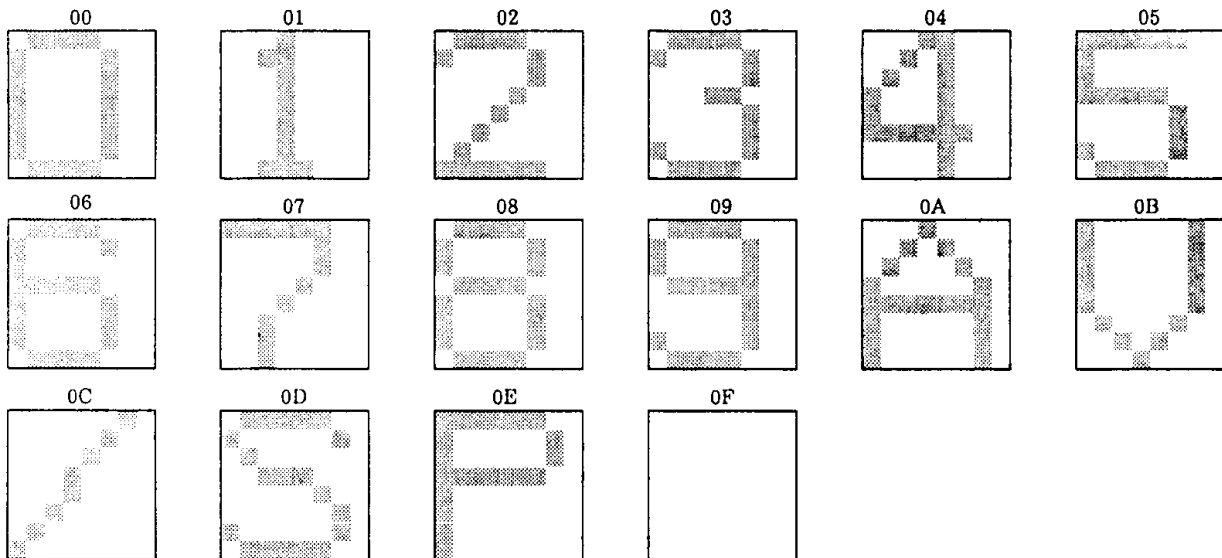
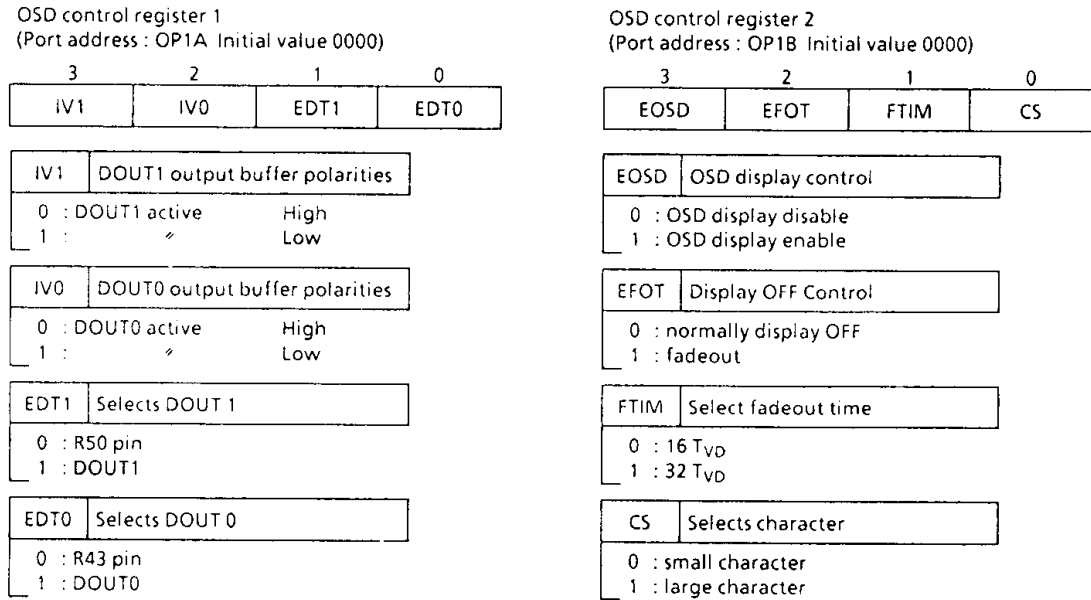

Figure 3-7. Address of the Character ROM and Character Pattern

3.2.5 Control of OSD Circuit

The OSD circuit is controlled by command registers 1 and 2 (OP1A, OP1B) and character code control registers 1, 2 and 3 (OP0A, OP0B, OP0C). OP1A controls the OSD output pin and OP1B controls character size and the display off method (display normally off, fadeout). Character code control registers OP0A, OP0B and OP0C correspond to the first, second and third display characters, respectively.

When all settings are completed and bit 3 (EOSD) of OP1B is set to "1", the character data read from the character ROM address indicated by the character code control register is output to the DOUT pin.



Note. T_{VD} : The period of vertical synchronous signal

Figure 3-8. Congrol Command Register

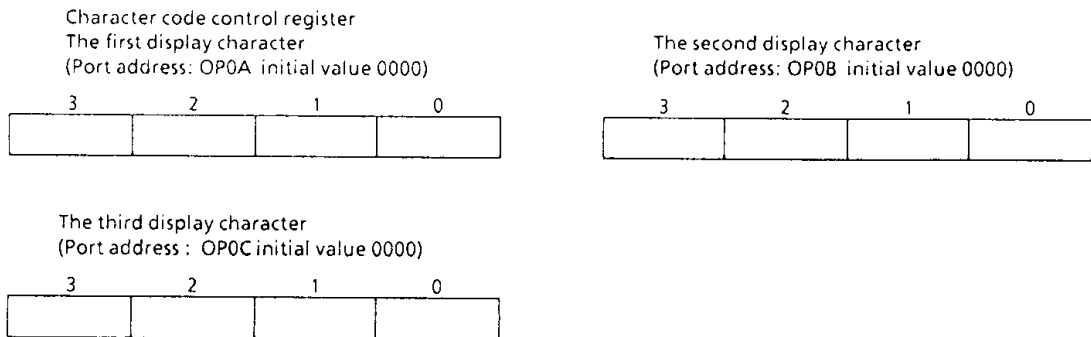

Figure 3-9. Character Code Control Register

3.3 3-bit A/D Converter (Comparator) Input

Comparator input consists of a 3-bit D/A converter and a comparator. The AFC input voltage level can be detected in 8 stages by distinguishing bit 0 of IP07 while varying the comparison voltage (D/A converter output voltage) of the comparator with the command registre (OP12). The comparator is disabled after a reset.

3.3.1 Circuit Configuration

Figure 3-11 shows the comparator input circuit configuration.

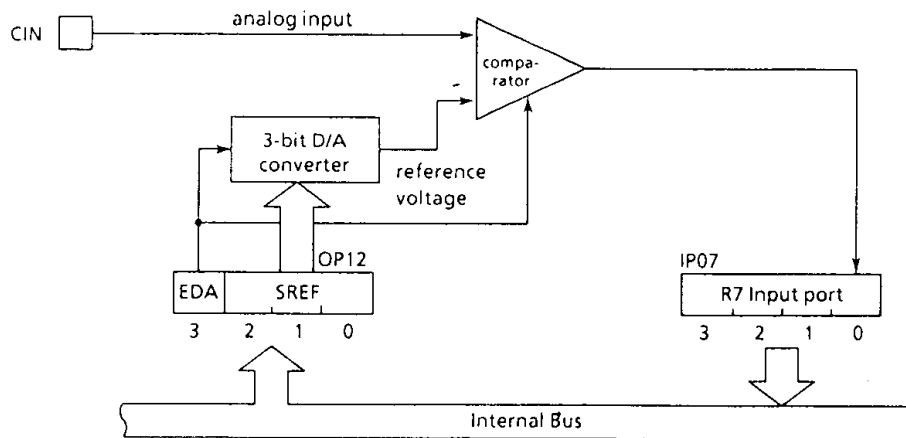
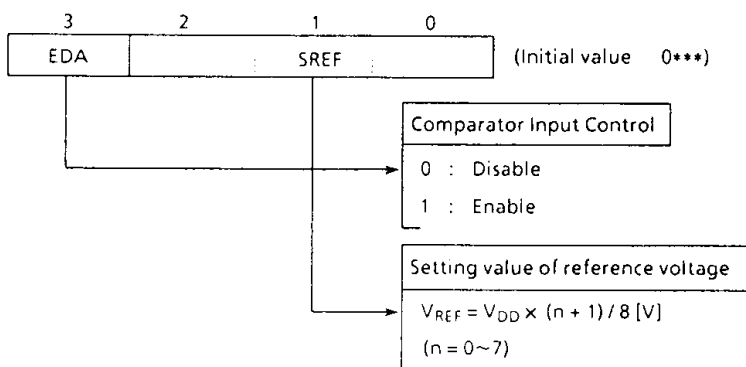

Figure 3-11. Comparator Input Circuit

3.3.2 Control of Comparator Input

The comparison voltage of the comparator is set with the lower 3 bits of the command register (OP12). Table 3-3 shows the comparison voltage when V_{DD} = 5V.

Comparator input control command register (Port address OP12)



OP12			Reference voltage [V]
2	1	0	
0	0	0	0.62
0	0	1	1.25
0	1	0	1.87
0	1	1	2.50
1	0	0	3.12
1	0	1	3.75
1	1	0	4.37
1	1	1	5.00

Table 3-3. Reference Voltage

Figure 3-12. Control Command Register

3.4 D/A Converter (PWM) Output

47C236A/336A have one built-in pulse width modulation (\overline{PWM}) output channel. D/A converter output can easily be obtained by attaching a low-pass filter. PWM output goes to the R41 (\overline{PWM}) port. When this port is used for \overline{PWM} output, set the corresponding R41 output latch to "1". The R41 output latch is initialized to "1" during resets. \overline{PWM} output is controlled by the buffer selector (OP17) and data transfer buffer (OP18). Writing "CH" to the buffer selector sends \overline{PWM} data written to the data transfer buffer to the \overline{PWM} data latch and switches to \overline{PWM} output. The \overline{PWM} data sent to the \overline{PWM} data latch are held until overwritten.

The buffer selector, data transfer buffer and \overline{PWM} data latch are cleared to "0" (\overline{PWM} output at "1" level) during resets and holds.

3.4.1 Circuit Configuration

Figure 3-13 shows the pulse width modulation circuit configuration.

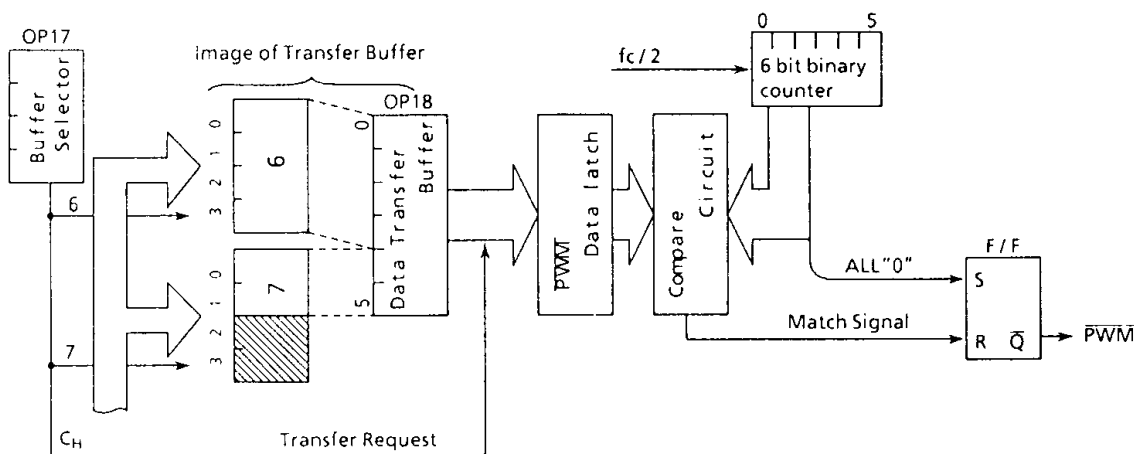

Figure 3-13. Pulse Width Modulation Circuit

3.4.2 Output Waveform of PWM Circuit

\overline{PWM} Output

With 6-bit resolution PWM output, one cycle is $T_N = 27/f_c$ [sec]. When 6-bit data are k ($k = 0-63$), the low level pulse width is $k \times t_0$. Figure 3-14 shows the PWM output timing.

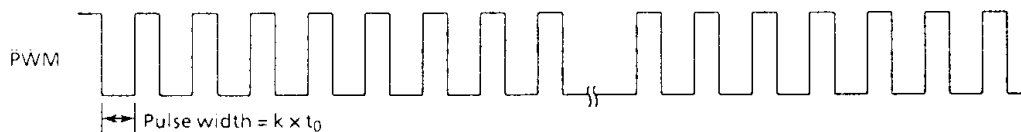

Figure 3-14. \overline{PWM} Output Timing

3.4.3 Control of PWM Circuit (Data transfer)

PWM output is controlled by writing output data to the data transfer buffer (OP18). Output data are written in segments using the buffer selector (OP17). Buffer numbers are assigned to the segmented data transfer buffer and the data are written using the following procedure in accordance with the chart shown in Table 3-4.

- ① Write the numbers of the buffers to which data are to be written to the buffer selector (OP17).
- ② Write the corresponding PWM data to the selected buffer (OP18).
- ③ Repeat steps ① and ② until all of the output data have been written to the transfer buffer.
- ④ When all of the output data have been written, write "CH" to the buffer selector.

The previous PWM data are output while the next output data are being written to the transfer buffer. A maximum time of $29/f_c[\text{sec}]$ (at 4MHz, 128 μs) is required from the time "CH" is written to the buffer selector until PWM output is switched.

Buffer Number (OP17)	Correspondence to bit (OP18)	Mode	PWM Output
6	Bit of PWM 3 ~ 0	Write	Preceding data
7	Bit of PWM 5 ~ 4	Write	Preceding data
C	None	Transfer	Present data

Table 3-4. The Bit and Buffer Number of Data Transfer Buffer

3.5 Remote Control Pre-processor

The remote control pre-processor counts the edge-to-edge time of the input pulse and generates an interrupt request each time that the switching edge of an input pulse is detected. Remote control signal waveform which has been rectified by the receiver is input to the R80 (INT2) pin.

3.5.1 Circuit Configuration

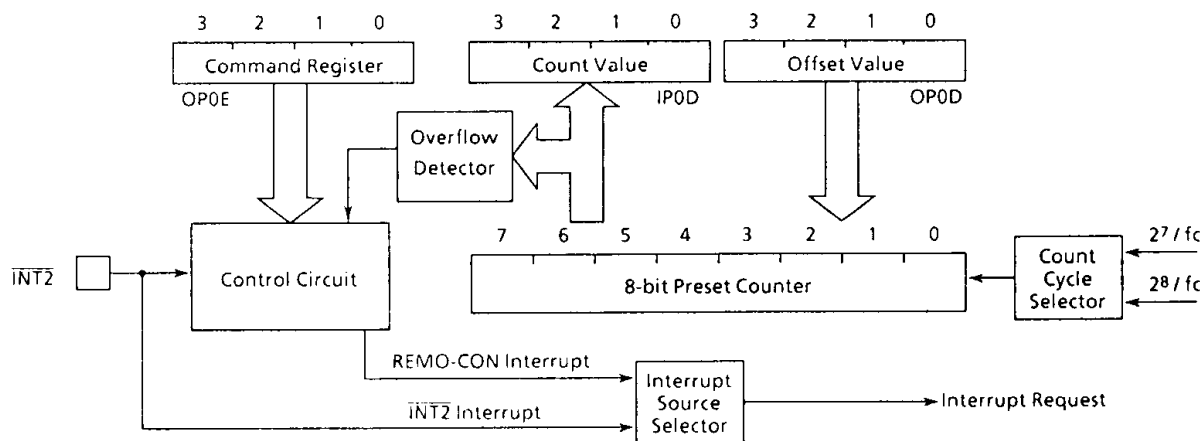

Figure 3-15. Remote Control Pre-processor

3.5.2 Control of Remote Control Pre-processor

The remote control pre-processor is controlled by the command register (OP0E) Also, external interrupt 2 is used to interrupt source. At reset, INT2 is selected, so a remote control discrimination (REMO-CON) interrupt is selected by command. Interrupt enable master F/F (EIF) and interrupt enable register (EIR) are used to enable/disable remote control discrimination interrupt. The interrupt priority is the same as for external interrupt 2.

REMO-CON pre-processor command register (Port address OP0E)

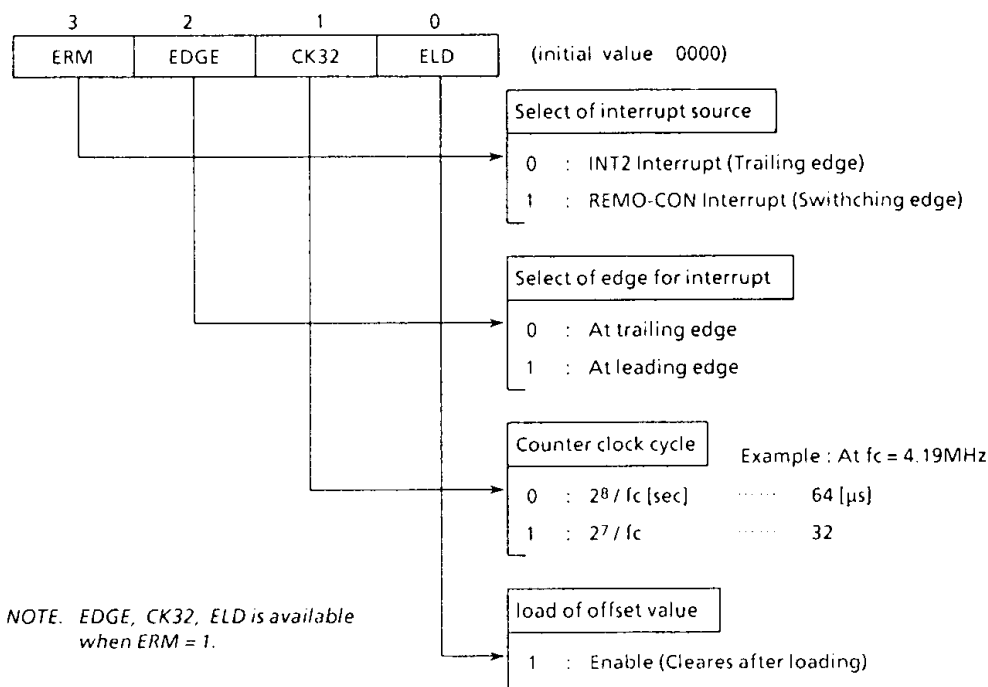

Figure 3-16. Command Register

(1) 8-bit preset counter

This is a binary counter which counts the time from edge to next edge. A value of offset value register (OP0D) are loaded to the lower 4 bits and the value of the upper 4 bits are stored to the count value register (IP0D).

Offset value is loaded in the following cases :

- ① When ELD (bit 0 of the OP0E) is set to "1".
- ② When there is an overflow of the lower 4 bits.
- ③ When an edge is detected.

Count value is stored in the following cases :

- ① When the upper 4 bits are all "1".
- ② When an edge is detected.

(2) Reference time and detection time

The reference time must be created before measuring the pulse width of the remote control signal waveform. Reference time is set the value shown in Table 3-5 by the count cycle of the preset counter selected with the OP0E and the offset value set to the OP0D. Therefore, the product of the reference time and the count value read from the IP0D becomes the detection time.

However, a worst error of the detection time is equivalent to reference time.

Count clock cycle	Offset value (HEX)	Reference time (n = 0 to 15)
$2^7 / f_c$ [sec]	0 to F	$(2^{11} - n \times 2^7) / f_c$ [sec]
$2^8 / f_c$	0 to F	$(2^{12} - n \times 2^8) / f_c$

Table 3-5. Set value of reference time

(3) Remote control pre-processing operation

First, set the offset value for creating the reference time to the OP0D. The offset value is loaded to the lower 4 bits of preset counter by setting ELD to "1". ERM can also be set to "1" at the same time. Setting ERM starts counting. ELD is cleared after loading but it is automatically loaded during the count by an overflow of the lower 4 bits.

After storing the count value in the IP0D by detecting the switching edge (leading/trailing) of the input pulse, the preset counter again loads the offset value to the lower 4 bits, clears to "0" the upper 4 bits and restarts counting.

An interrupt request is generated at this time. Therefore, read the count value in the interrupt service routine. The next interrupt is disabled until the stored count value is read. Switching edges can select in one by one using EDGE.

If the upper 4 bits of counter becomes "1111_b" before the next edge is accepted, it is judged to be an overflow and the interrupt is generated.

In this case, IP0D is set to "F_H" and it can be identified to be the overflow interruption. The input pulse width of both "H" and "L" levels must be more than $192/f_c$ [sec]. If any shorter pulse than $192/f_c$ [sec] may be expected, put the dummy instruction [IN %IP0D, A] reading out from count value register in the main routine.

Even if ERM is "0", when an INT2 interrupt source is enabled (determined by EIF,EIR), an interrupt request is generated by a falling edge of input pulse.

Figure 3-17. shows the operation timing the remote control pre-processor.

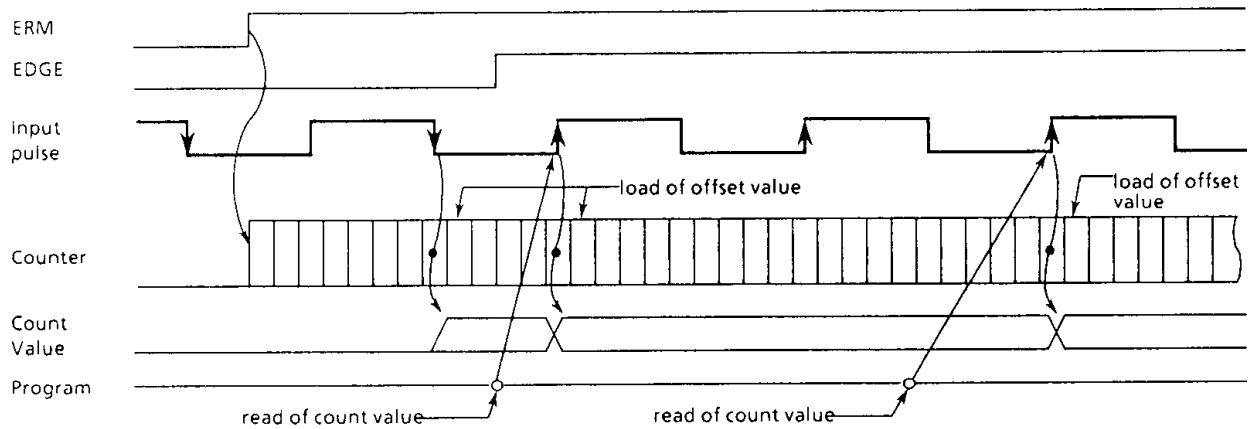
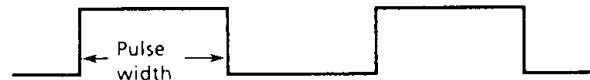

Figure 3-17. Timing chart

Example: To store a count value to RAM [10H] that pulse width of input pulse is measured.



Main routin

```

OUT      #5, %OP0D      ; Offset value register set to "5".
OUT      #0FH, %OP0E    ; Interrupt enable with setting count cycle to 32 μsec,
                        ; leading edge detection mode.

CLR      0, 0           ; Clear to RAM [00H]0 as interrupt status flag.
LD       A, #0001B     ; Interrupt enable
XCH     A, EIR
EICLR   IL, #111110B
:

```

INT2 service routin

```

TEST     0, 0           ; Skip, if interrupt status flag is "0".
B        ST0
LD       HL, #10H      ; HL ← 10H
IN       %IP0D, @HL    ; RAM [10H] ← Count value
CLR      0, 0           ; Clearing interrupt status flag.
OUT      #0EH, %OP0E   ; Se to leading edge detection mode.
B        SEND
ST0: SET  0, 0           ; Setting interrupt status flag.
OUT      #0AH, %OP0E   ; Set to trailing edge detection mode.
IN       %IP0D, A      ; Dummy
SEND:
:

```

※ Calculation of pulse width with the above program when the count value stored to the RAM [10H] is "9".

When the clock frequency is 32μs ($f_c = 4.19\text{MHz}$) and the offset value is "5", the reference time will be as follows :

$$(2^{11} - 5 \times 2^4) / f_c = 336 [\mu\text{s}]$$

Thus, the detection time (pulse width) will be $336 \times 9 = 3.02[\text{ms}]$ (including an error of 336μs max.)

ELECTRICAL CHARACTERISTICS

ABSOLUTE MAXIMUM RATINGS (V_{SS} = 0V)

PARAMETER	SYMBOL	PINS	RATING	UNIT
Supply Voltage	V _{DD}		-0.3~7	V
Input Voltage	V _{IN}		-0.3~V _{DD} + 0.3	V
Output Voltage	V _{OUT1}	Except sink open drain pin	-0.3~V _{DD} + 0.3	V
	V _{OUT2}	Sink open drain pin except R7 port	-0.3~10	
Output Voltage (per 1 pin)	I _{OUT1}	R6 port	10	mA
	I _{OUT2}	R4, R5, R7, R8 port	3.2	
Output Current (Total)	Σ I _{OUT1}	R6 port	40	mA
Power Dissipation [T _{opr} = 70°C]	PD		600	mW
Soldering Temperature (time)	T _{sld}		260 (10sec)	°C
Storage Temperature	T _{stg}		-55~125	°C
Operating Temperature	T _{opr}		-20~70	°C

RECOMMENDED OPERATING CONDITIONS (V_{SS} = 0V, T_{opr} = -20~70°C)

PARAMETER	SYMBOL	PINS	CONDITION	Min.	Max.	UNIT
Supply Voltage	V _{DD}		in the Normal mode	4.5	6.0	V
			in the HOLD mode	2.0		
Input High Voltage	V _{IH1}	Except Hysteresis Input	V _{DD} ≥ 4.5V	V _{DD} × 0.7	V _{DD}	V
	V _{IH2}	Hysteresis Input		V _{DD} × 0.75		
	V _{IH3}		V _{DD} < 4.5V	V _{DD} × 0.9		
Input Low Voltage	V _{IL1}	Except Hysteresis Input	V _{DD} ≥ 4.5V	0	V _{DD} × 0.3	V
	V _{IL2}	Hysteresis Input			V _{DD} × 0.25	
	V _{IL3}		V _{DD} < 4.5V	V _{DD} × 0.1		
Clock Frequency	f _c	XIN, XOUT		0.4	4.2	MHz
	f _{osc}	OSC1, OSC2		6	10	

Notes. Input Voltage V_{IH3}, V_{IL3} : in the HOLD mode

D.C. CHARACTERISTICS ($V_{SS} = 0V$, $T_{opr} = -20 \sim 70^{\circ}C$)

PARAMETER	SYMBOL	PINS	CONDITION	Min.	Typ.	Max.	UNIT
Hysteresis Voltage	V_{HS}	Hysteresis Input		—	0.7	—	V
Input Current	I_{IN1}	K0 port, TEST, RESET, HOLD	$V_{DD} = 5.5V$,	—	—	± 2	μA
	I_{IN2}	R port (open drain)	$V_{IN} = 5.5V/0V$				
Input Resistance	R_{IN1}	K0 port with pull-up		30	70	150	K Ω
	R_{IN2}	RESET		100	220	450	
Output Leakage Current	I_{LO}	Open drain port	$V_{DD} = 5.5V$, $V_{OUT} = 5.5V$	—	—	2	μA
Output High Voltage	V_{OH}	R6 Port	$V_{DD} = 4.5V$, $I_{OH} = -200\mu A$	2.4	—	—	V
Output Low Voltage	V_{OL}	XOUTを除く	$V_{DD} = 4.5V$, $I_{OL} = -1.6mA$	—	—	0.4	V
Output Low Current	I_{OL}	R6 port	$V_{DD} = 4.5V$, $V_{OL} = 1.0V$	—	10	—	mA
Supply Current (in the Normal mode)	I_{DD}		$V_{DD} = 5.5V$, $f_c = 4MHz$	—	3	6	mA
Supply Current (in the HOLD mode)	I_{DDH}		$V_{DD} = 5.5V$	—	0.5	10	μA

Note 1. Typ. values show those at $T_{opr} = 25^{\circ}C$, $V_{DD} = 5V$.

Note 2. Input Current I_{IN1} : The current through resistor is not included, when the pull-up/pull-down resistor is contained.

Note 3. Supply Current : $V_{IN} = 5.3V/0.2V$
 The K0 port is open when the pull-up/pull-down resistor is contained.
 The voltage applied to the R port is within the valid range V_{IL} or V_{IH} .

A/D CONVERTER CHARACTERISTICS

PARAMETER	SYMBOL	PINS	CONDITION	Min.	Typ.	Max.	UNIT
Analog input voltage	V_{AIN}	CIN		V_{SS}	—	V_{DD}	V
A/D conversion error	—			—	—	$\pm \frac{1}{4}$	LSB

A.C. CHARACTERISTICS ($V_{SS} = 0V$, $V_{DD} = 4.5 \sim 6.0V$, $T_{opr} = -20 \sim 70^{\circ}C$)

PARAMETER	SYMBOL	CONDITION	Min.	Typ.	Max.	UNIT
Instruction Cycle time	t_{cy}		1.9	—	20	μs
High level Clock Pulse Width	t_{wCH}	For external clock operation	80	—	—	ns
Low level Clock Pulse Width	t_{wCL}					

RECOMMENDED OSCILLATING CONDITIONS (V_{SS} = 0V, V_{DD} = 4.5 to 6.0V, T_{opr} = -30 to 70°C)

- (1) 4MHz
 - Ceramic Resonator
 - CSA4.00MG (MURATA) C_{XIN} = C_{XOUT} = 30pF
 - KBR-4.00MS (KYOCERA) C_{XIN} = C_{XOUT} = 30pF
 - Crystal Oscillator
 - 204B-6F 4.0000 (TOYOCOM) C_{XIN} = C_{XOUT} = 20pF

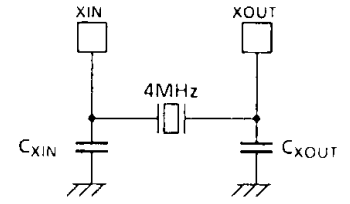

- (2) 400KHz
 - Ceramic Resonator
 - CSB400B (MURATA) C_{XIN} = C_{XOUT} = 220pF, R_{XOUT} = 6.8KΩ
 - KBR-400B (KYOCERA) C_{XIN} = C_{XOUT} = 100pF, R_{XOUT} = 10KΩ

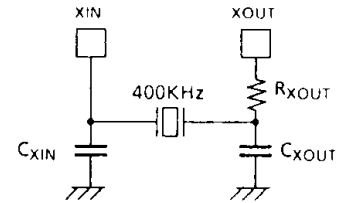

TYPICAL CHARACTERISTICS

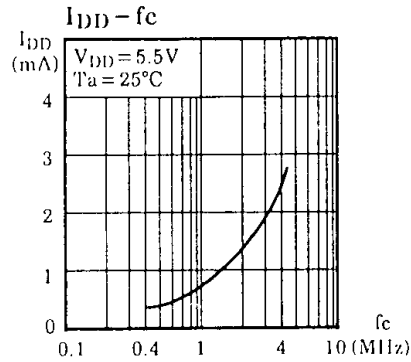
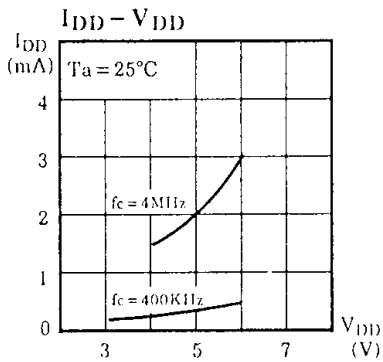
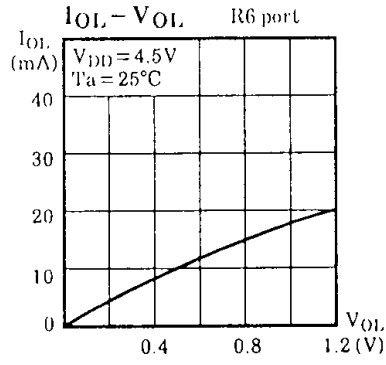
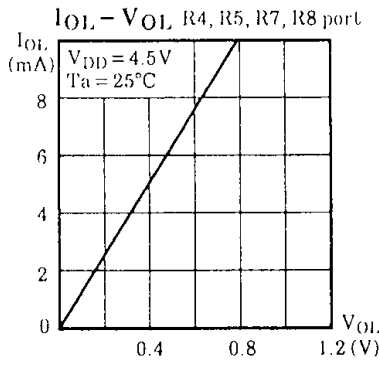
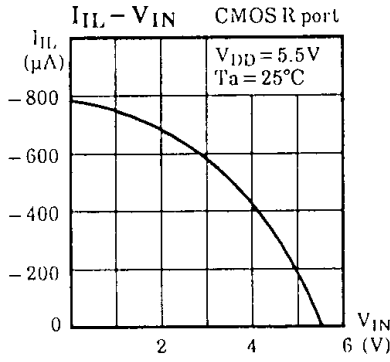
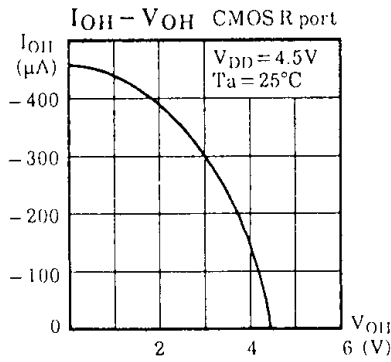
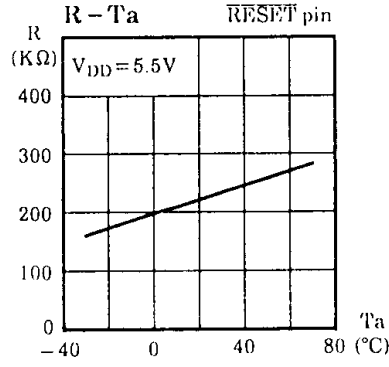
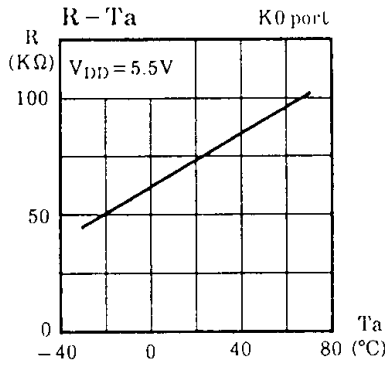

Input/Output Circuitry

(1) Control pins

Input/output circuitries of the 47C236A/336A control pins are shown below.

CONTROL PIN	I/O	CIRCUITRY	REMARKS
XIN XOUT	Input Output		Resonator connecting pins $R = 1K\Omega$ (typ.) $R_f = 1.5M\Omega$ (typ.) $R_0 = 2K\Omega$ (typ.)
$\overline{\text{RESET}}$	Input		Hysteresis input Contained pull-up resistor $R_{IN} = 220K\Omega$ (typ.) $R = 1K\Omega$ (typ.)
$\overline{\text{HOLD}} (\overline{\text{KE}}0)$	Input (Input)		Hysteresis input (Sense input) $R = 1K\Omega$ (typ.)
TEST	Input		Contained pull-down resistor $R_{IN} = 70K\Omega$ (typ.) $R = 1K\Omega$ (typ.)
OSC1 OSC2	Input Output		Oscillation terminals for DOS $R = 1K\Omega$ (typ.) $R_f = 1.5M\Omega$ (typ.) $R_0 = 2K\Omega$ (typ.)
$\overline{\text{HD}}$ $\overline{\text{VD}}$	Input		Synchronous signal input Hysteresis input $R = 1K\Omega$ (typ.)

(2) I/O port

The input/output circuitries of the 47C236A/336A I/O port are shown below, any one of the circuitries can be chosen by a code (PD-PF) as a mask option.

PORT	I/O	INPUT/OUTPUT CIRCUITRY and CODE			REMARKS
		PD	PE	PF	
K0	Input				<p>Pull-up/Pull-down resistor</p> <p>$R_{IN} = 70k\Omega$ (typ.) $R = 1k\Omega$ (typ.)</p>
R4 R5	I/O				<p>Sink open drain output</p> <p>Initial "Hi-Z"</p> <p>$R = 1k\Omega$ (typ.)</p>
R6	I/O				<p>Push-pull output</p> <p>Initial "Low"</p> <p>High drive current output</p> <p>$I_{OL} = 10mA$ (typ.) $R = 1k\Omega$ (typ.)</p>
R7	I/O	<p>CIN</p>	<p>R71-R73</p>	<p>Sink open drain output</p> <p>Initial "Hi-Z"</p> <p>Comarater input (R70)</p> <p>$R = 1k\Omega$ (typ.)</p>	
R8	I/O				<p>Sink open drain output</p> <p>initial "Hi-Z"</p> <p>Hysteresis input</p> <p>$R = 1k\Omega$ (typ.)</p>