

CMOS 4-Bit Microcontroller

TMP47C430N

TMP47C430M

The 47C430 is based on the TLCS-470 CMOS series. The 47C430 have on-screen display circuit (OSD) to display characters and marks which indicate channel or time on TV screen, A/D converter (comparator) input, and D/A converter output such as TV.

Part No.	ROM	RAM	Package
TMP47C430N	4096 x 8-bit	256 x 4-bit	SDIP28-P-400
TMP47C430M			SOP28-P-450

Features

- 4-bit single chip microcomputer
- Instruction execution time: 1.9 μ s (at 4.2MHz),
- 92 basic instructions
- Table look-up instructions
- Subroutine nesting: 15 levels max.
- 5 interrupt sources (External: 2, Internal: 3)
 - All sources have independent latches each, and multiple interrupt control is available.
- I/O port (19 pins)
 - Input 2 ports 5 pins
 - I/O 5 ports 14 pins
- Interval Timer
- Two 12-bit Timer/Counters
 - Timer, event counter, and pulse width measurement mode
- Watchdog Timer
- On-screen display circuit
 - Character patterns: 48 characters
 - Characters displayed: 16 columns x 2 lines
 - Composition: 8 x 8 dots (smoothing function)
 - Size of character: 2 kinds (line by line)
 - Color of character: 3 kinds (character by character)
 - Variable display position: Horizontal/vertical 64 steps
- D/A converter (Pulse width modulation) outputs
 - 14-bit resolution 1 channel
 - 6-bit resolution 1 channels

- 4-bit A/D converter (Comparator) input (4 channels)
- Horizontal synchronous signal is detected by timer/counter
- Remote control signal preprocessing capability
- High current outputs
 - LED direct drive capability (typ. 20mA x 4 bits).
- Hold function: Battery/Capacitor back-up

SDIP28-P-400

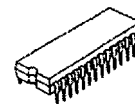

TMP47C430N

SOP28-P-450



TMP47C430M

The information contained here is subject to change without notice.

The information contained herein is presented only as guide for the applications of our products. No responsibility is assumed by TOSHIBA for any infringements of patents or other rights of the third parties which may result from its use. No license is granted by implication or otherwise under any patent or patent rights of TOSHIBA or others. These TOSHIBA products are intended for usage in general electronic equipments (office equipment, communication equipment, measuring equipment, domestic electrification, etc.) Please make sure that you consult with us before you use these TOSHIBA products in equipments which require high quality and/or reliability, and in equipments which could have major impact to the welfare of human life (atomic energy control, spaceship, traffic signal, combustion control, all types of safety devices, etc.). TOSHIBA cannot accept liability to any damage which may occur in case these TOSHIBA products were used in the mentioned equipments without prior consultation with TOSHIBA.

Pin Assignments (Top View)

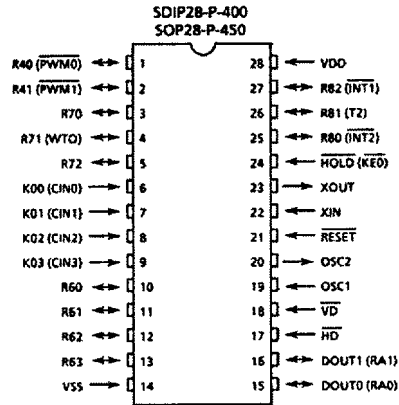

Block Diagram

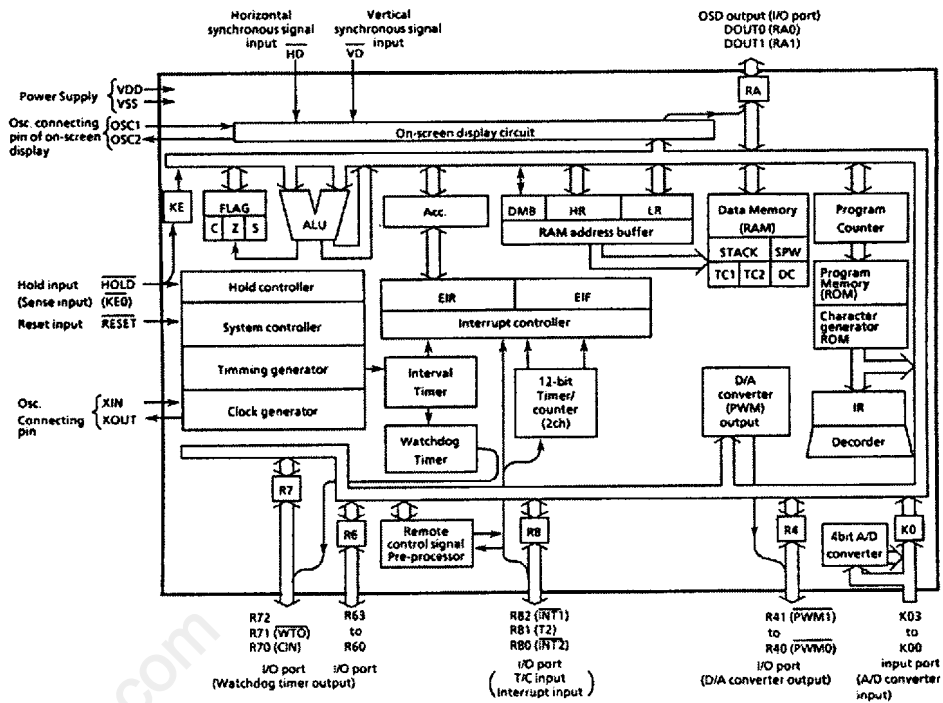

Pin Function

Pin Name	Input/Output	Function	
K03 to K00	Input	4-bit Input port	4-bit A/D Converter input
R41 (PWM1)	I/O (output)	2-bit I/O port with latch. When used as input port or D/A converter outputs pins, the latch must be set to "1".	6-bit D/A converter (PWM) output
R40 (PWM0)			14-bit D/A converter (PWM) output
R63 to R60	I/O	4-bit I/O port with latch. When used as input port, the latch must be set to "1".	
R72	I/O	4-bit I/O port with latch.	
R71 (WTO)	I/O (output)	When used as input port, watchdog timer output pin, or A/D converter input pin, the latch must be set to "1".	Watchdog timer output
R70 (CIn)	I/O (input)		
R82 (INT1)	I/O (output)	4-bit I/O port with latch.	External interrupt 1 input
R81 (T2)	I/O (Input)	When used as input port, external interrupt input pin, or timer/counter external input pin, the latch must be set to "1".	Timer/Counter 2 external input
R80 (INT2) / HOLD	I/O (Input)		External interrupt 2 input
DOUT1 (RA1)	Output (I/O)	RGB Output	2-bit I/O port with latch.
DOUT0 (RA0)			When used as input port, the latch must be set to "1"
H \bar{D} , V \bar{D}	Input	Horizontal synchronous signal input, Vertical synchronous signal input	
OSC1, OSC2	input, output	Resonator connecting pin of on-screen display circuit	
XIN, XOUT	input, output	Resonator connecting pin. For inputting external clock, XIN is used and XOUT is opened.	
RESET	Input	Reset signal input	
HOLD (KE0)	input (input)	HOLD request/release signal input	Sense input
VDD	Power Supply	+5V	
VSS		0V (GND)	

Operational Description

1. System Configuration

• Internal CPU Function

They are the same as those of the 47C660/860 except program memory (ROM), data memory (RAM) and system clock controller.

• Peripheral Hardware Function

① Input/Output Ports

② Interval Timer

③ Timer/Counters (TC1,TC2)

④ Watchdog Timer

⑤ Remote control pulse detector

⑥ On-screen display (OSD) control circuit

⑦ A/D Converter (Comparator) input

⑧ D/A converter (Pulse Width Modulation) output

The description has been provide with priority on functions (①, ③, ⑥, ⑦, and⑧) added to and changed from 47C660/860.

2. Internal CPU Function

2.1 Program Memory (ROM)

Programs are stored in address 0000 to 0FFF_H of 47C430. By the ROM data reference instruction [LDH A,@DC+, LDL A,@DC], the fixed data in address 0000 to 0FFF_H can be loaded to the accumulator, respectively.

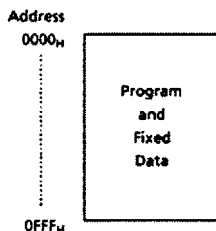

Figure 2-1. Program Memory

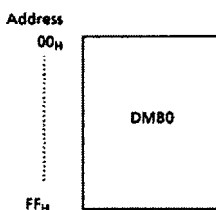

Figure 2-2. Data Memory (RAM)

2.3 Operation Clock Control

On the 47C430 only single clock mode is available. As single clock mode is automatically selected at the initialization, there

is no necessary to set system clock control command register (OP16).

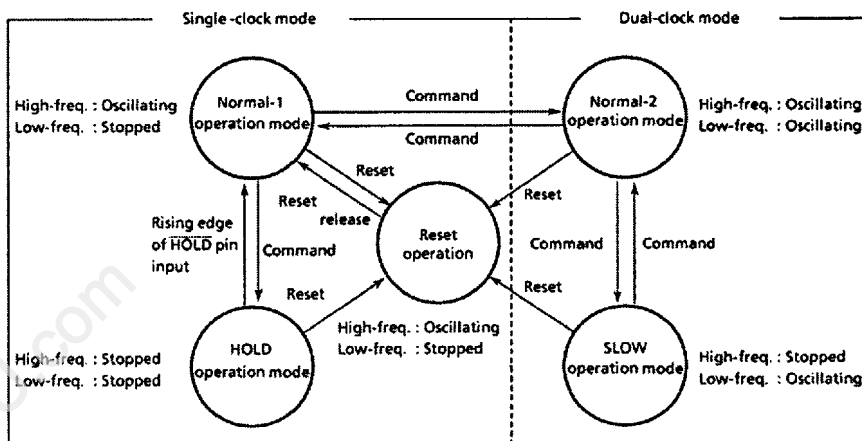

Figure 2-3. Operation Mode Transition Diagram

3. Peripheral Hardware Function

3.1 I/O Ports

The 47C434A/634A have 7 I/O ports (19 pins) each as follows

- ① K0 ; 4-bit input (shared with comparator inputs)
- ② R4 ; 2-bit input/output (shared with pulse width modulation output)
- ③ R6 ; 4-bit input/output
- ④ R7 ; 3-bit input/output (shared with comparator input and watchdog timer output)
- ⑤ R8 ; 3-bit input/output (shared with external interrupt input and timer/counter input)

- ⑥ RA ; 2-bit input/output (shared with on-screen display output)
- ⑦ KE ; 1-bit sense input (shared with hold request/release signal input)

The description has been provide with priority on functions (①, ②, ④ and ⑤) added to and changed from 47C660/860, and it describes port ⑥, which item of on-screen display circuit.

(1) Port K0 (K03-K00)

The 4-bit input port. Port K0 is shared digital input with the A/D converter (comparator) input. The K0 port input selector (OP13) determines whether this port is to be used for digital or comparator input. The most significant bit of the K0 port input selector is set to "1" for digital input and to "0" for comparator input.

The K0 port selector is initialized to "0" during reset.

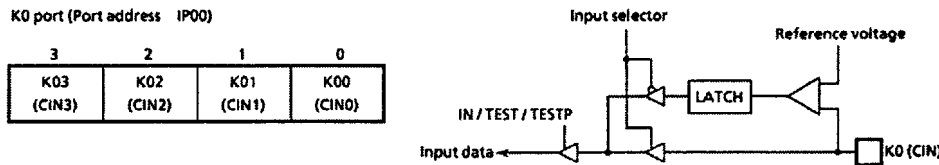

Figure 3-1. Port K0

(2) Port R4 (R41 to R40)

This is a 2-bit I/O port with latch. It is a port common to D/A converter (PWM) output port. R4 port output buffers are Tri-state, and each bit of them can be controlled independently by the program. Controlling the Tri-state is performed by the command register accessed as port address OP00. When some bit of the OP00 is 0, the corresponding bit of the output buffers

becomes High-impedance state. The output latch should be set to "1" when the port is used as PWM output port, the PWM output should be to "H" level (PWM data is all "0") when the port is used as R4 port. The output buffers should be set to high impedance state, when the port is used as input port. And the R4 output latch be set to "1", PWM output be set to "High" level, and the output buffer be set to High-impedance state during reset.

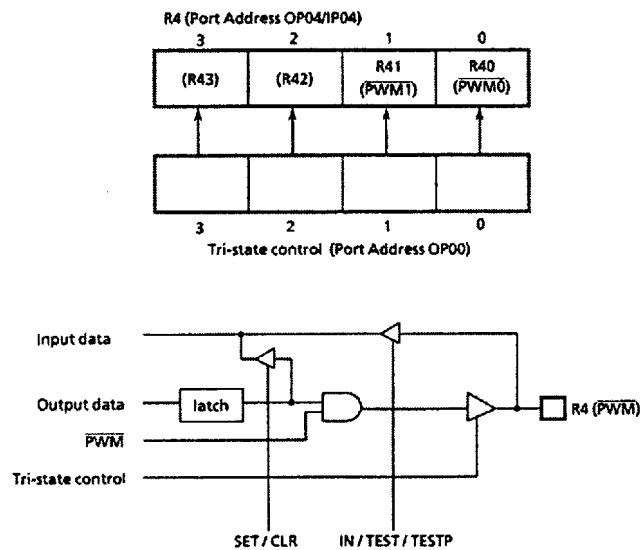

Figure 3-2. Port R4 (PWM)

(3) Port R7 (R72 to R70)

This is a 3-bit I/O port with latch.

R7 port output buffers are Tri-state, and each bit of them can be controlled independently by the program. Controlling the Tri-state is performed by the command register accessed as port address OP01. When some bit of the OP01 is 0, the corresponding bit of the output buffers becomes High-impedance state

Pin R71 (\overline{WTO}) is shared with the watchdog timer output.

The output latch should be set to "1" when the port is used as \overline{WTO} output port. The output buffers should be set to High impedance state, when the port is used as input port, and the output buffer be set to High-impedance state during reset. R73 pin does not exist actually but R73 has the latch.

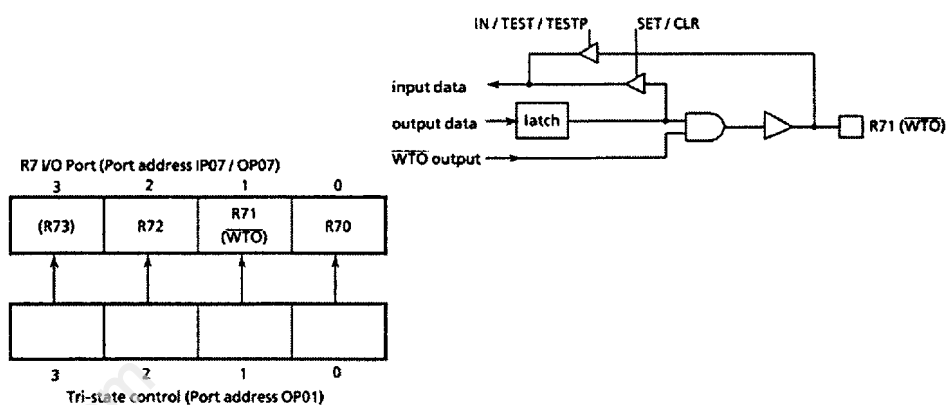

Figure 3-3. Port R7

(4) Port R8 (R82 to R80)

This is a 3-bit I/O port with latch.

R8 port output buffers are Tri-state, and each bit of them can be controlled independently by the program. Controlling the Tri-state is performed by the command register accessed as port address OP02. When some

bit of the OP02 is 0, the corresponding bit of the output buffers becomes High-impedance state

The output buffers should be set to High impedance state, when the port is used as input port, and the output buffer be set to High-impedance state during reset. R83 pin does not exist actually but R83 has the latch. There is no timer/counter1 external input pin (T1).

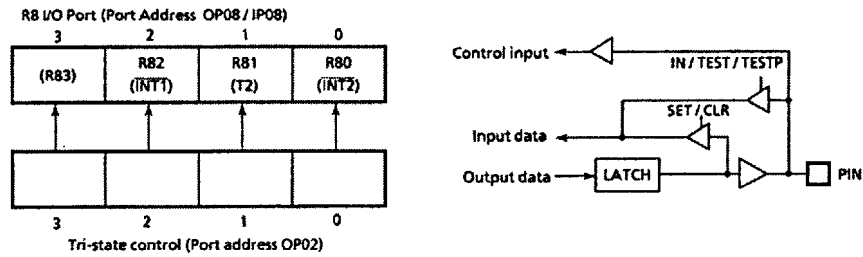

Figure 3-4. Port R8

www.DataSheet4U.com

Table 3-1 Port Address Assignments and Available I/O Instructions

Port address (H)	Port		I/O instruction						
	Input (IP ²)	Output (OP ²)	IN %p, A IN %p, @HL	OUT A, %p OUT @HL, %p	OUT #k, %p	OUTB@HL	SET %p, b CLR %p, b	TEST %p, b TESTP %p, b	SET @L CLR @L TEST @L
00 _H	K0 input port	Tri-state(R4 port)control	○	○	○	-	-	○	-
01	---	Tri-state(R7 port)control	-	○	○	-	-	○	-
02	---	Tri-state(R8 port)control	-	○	○	-	-	○	-
03	---	---	-	-	-	-	-	-	-
04	R4 input port	R4 output port	○	-	○	-	○	○	○
05	---	---	-	-	-	-	-	-	-
06	R6 input port	R6 output port	○	○	○	-	○	○	○
07	R7 input port	R7 output port	○	○	○	-	○	○	○
08	R8 input port	R8 output port	○	○	○	-	○	○	-
09	---	---	-	-	-	-	-	-	-
0A	RA input port	RA output port	○	○	○	-	○	○	-
0B	---	---	-	-	-	-	-	-	-
0C	---	OSD command selector	-	○	○	-	-	-	-
0D	Remote control count value register	Remote control offset valve register	○	○	○	-	-	-	-
0E	status input (Note 2)	Remote control single preprocess circuit control	○	○	○	-	-	○	-
0F	---	---	-	-	-	-	-	-	-
10 _H	undefined	Hold operation mode	-	○	-	-	-	-	-
11	undefined	---	-	-	-	-	-	-	-
12	undefined	A/D converter input control1	-	○	-	-	-	-	-
13	undefined	A/D converter input control2	-	○	-	-	-	-	-
14	undefined	---	-	-	-	-	-	-	-
15	undefined	Watchdog timer control	-	○	-	-	-	-	-
16	undefined	---	-	-	-	-	-	-	-
17	undefined	PWM buffer selector	-	○	-	-	-	-	-
18	undefined	PWM data transfer buffer	-	○	-	-	-	-	-
19	undefined	Interval timer interrupt control	-	○	-	-	-	-	-
1A	undefined	OSD control	-	○	-	-	-	-	-
1B	undefined	---	-	-	-	-	-	-	-
1C	undefined	Timer/counter 1 control	-	○	-	-	-	-	-
1D	undefined	Timer/counter 2 control	-	○	-	-	-	-	-
1E	undefined	---	-	-	-	-	-	-	-
1F	undefined	---	-	-	-	-	-	-	-

Note1: "----" means the reserved state. Unavailable for the user programs.

Note 2: the status input of HOLD (KE0) pin.

3.2 Timer/Counter (TC1, TC2)

The 47C430 does not have timer/counter1 external input. Therefore, timer/counter1 can be used as internal timer mode

only. The other functions are equivalent to the timer/counters of the 47C660/860.

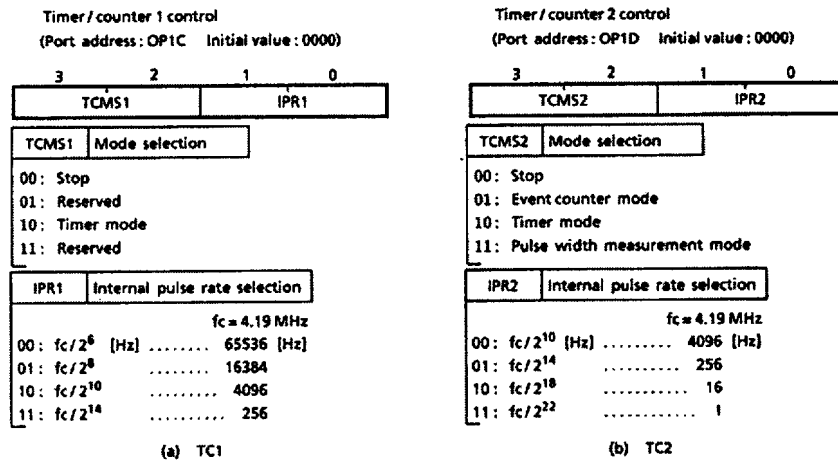

Figure 3-5. Timer/Counter Control Command Registers

3.3 On-Screen Display (OSD) Circuit

An on-screen display (OSD) circuit used to display characters and symbols in built into the TV screen.

A maximum of 32 characters, as 16 columns x 2 lines, out of 48 character patterns can be displayed at a time.

3.3.1 OSD Circuit Function

- ① Number of characters 48 kinds
- ② Number of characters displayed 32 characters (16 columns x 2 lines)

- ③ Composition of a character 8 x 8 dots (with smoothing function)
- ④ Size of character 2 kinds (selectable line by line)
- ⑤ Color of character 3 kinds (selectable character by character)
- ⑥ Display position variable horizontal 64 steps, vertical 64 steps

3.3.2 OSD Circuit Configuration

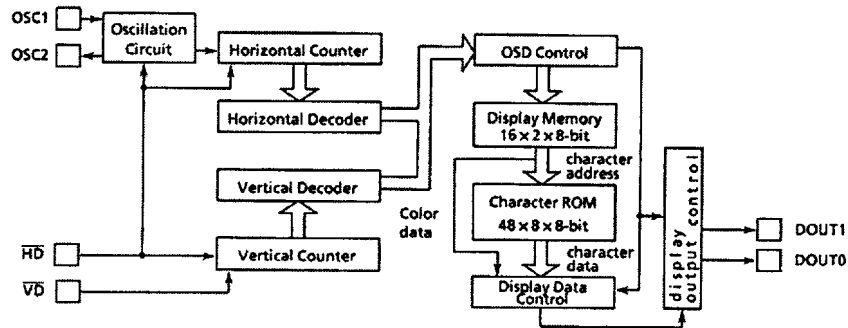

Figure 3-6. OSD Circuit

3.3.3 OSD Circuit Control

The OSD circuit is controlled by the command selector (OP0C) and control register (OP1A). Table 3-2 shows the relationship between OP0C and OP1A. OP1A is multiplexed with the six output control registers which control the display start position, color of character and character size of character, and the two transfer control registers which transfer data to the display memory.

The output control registers consist of 8 bits and all bits can be written by accessing OP1A two times. However, the second access is not required unless the second data are changed. The addressed "0 to 5" are assigned to the six output control registers. OP1A can be accessed by writing the address of the control register where data are to be changed to OP0C. The transfer control registers can be accessed by writing "6" or "7" to OP0C. The transfer control registers have a 12-bit configuration and can access OP1A three times succession. The first access sets which column is displayed with-

in one line 16 columns.

The second and third accesses written 6 bit of character data.

The display memory has a 16-columns x 8-bit x 2 lines configuration with a one-to-one correspondence to the number of columns displayed on the screen. The display data consist of 6 character data bits and 2 color data bits for a total of 8 bits. When "6" is written to OP0C, line 1 is stored to the display memory, when "7" is written to OP0C, line 2 is stored. That is after accessing OP0C, the character data specified the second and third times are written to the display memory area specified in the first OP1A access together with the color data loaded to control register DCR50. Thus color can be specified for each character. After setting of all control registers is completed, the character data read from the character ROM(00 to 2FH) are output to the DOUT0 and DOUT1 pins together with the color data by setting OP0C to "F".

Table 3-2 OSD Control Commands and Control Registers

OSD command selector (OP0C)	OSD control register to be accessed through OP1A			
0	Control for the horizontal start position of the first display line			
	DCR00	3 -	2 -	1 HS15
DCR01	HS13	HS12	HS11	HS10 (2st access)
1	Control for the vertical start position of the first display line			
	DCR10	3 -	2 -	1 VS15
DCR11	VS13	VS12	VS11	VS10 (2st access)
2	Control for the horizontal start position of the second display line.			
	DCR20	3 -	2 -	1 HS25
DCR21	HS23	HS22	HS21	HS20 (2st access)
3	Control for the vertical start position of the second display line.			
	DCR30	3 -	2 -	1 VS25
DCR31	VS23	VS22	VS21	VS20 (2st access)
4	Control for the character sizes,smoothing switch and OSD output polarities			
	DCR40	3 CS21	2 CS20	1 CS11
DCR41	ESM2	-	-	RGBIV (2st access)
5	Control for the color register and OSD output buffers'tri-state'			
	DCR50	3 -	2 DOUT00T	1 DOUT1DT
DCR51	-	-	EBF1	EBF0 (2st access)
6	display memory write mode for the first display line(address 00 to 0F)			
	DMA3	DMA2	DMA1	DMA0 (1st access)
	-	-	CRA5	CRA4 (2st access)
CRA3	CRA2	CRA1	CRA0 (3st access)	
7	display memory write mode for the second display line(address 10 to 1F)			
	DMA3	DMA2	DMA1	DMA0 (1st access)
	-	-	CRA5	CRA4 (2st access)
CRA3	CRA2	CRA1	CRA0 (3st access)	
E	display OFF			
F	display ON			

www.DataSheet4U.com

(1) Composition of character and smoothing function

Each character is composited by 8 x 8 dots. Each dot corresponds to a bit in the character ROM. Figure 3-7. (a) shows an example Composition of a character.

Smoothing function is the function to make characters

look smooth. In the time the smoothing function is enabled, additional dots are displayed in the middle of the place where two dots contact each other only at a corner. Controlling of the smoothing function is performed by ESMZ in the OSD control register DCR41. Figure 3-7.(b) shows an example of the smoothing function.

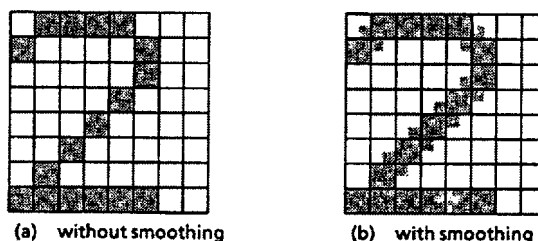

Figure 3-7. Composition of Character and Smoothing Function

(2) Character size and color to display

Size of the characters displayed on screen is selectable line by line from 2 sizes. The size of the first and second display line is designated by CS11 to CS10 and CS21 to CS20 in the OSD control register DCR40, respectively.

Table 3-3 shows the setting values and character sizes of DCR40.

Table 3-4 shows the display character sizes.

One out of seven colors can be selected for each character to be displayed and are determined by DOUT0DT and DOUT1DT of DCR50. The color data are written to the display memory automatically at the same time as character data are written.

Table 3-3 Designation of Character Size

Character size (DCR40)	second display line		first display line	
	CS21	CS20	CS11	CS10
small character	1	0	1	0
large character	0	1	0	1
display OFF	0	0	0	0

Table 3-4 Character Size

	small character	large character
dot size	$2T_{HD} \times 2T_{OSC}$	$4T_{HD} \times 4T_{OSC}$
character size	$16T_{HD} \times 16T_{OSC}$	$32T_{HD} \times 32T_{OSC}$

Note. T_{HD} : the period of horizontal synchronous signal
 T_{OSC} : the period of OSD clock oscillation

(3) Display start position

Display start position of each display line on screen can be shifted by software.

The vertical and horizontal display starting position for the first line is determined by HS10 to 15 and VS10 to 15 of DCR00 to 11.

The vertical and horizontal display starting position for the second line is determined by HS20 to 25 and VS20 to 25 of DCR20 to 31. Each has a resolution of 64 steps.

The control register and display line on screen are shown in Table 3-6.

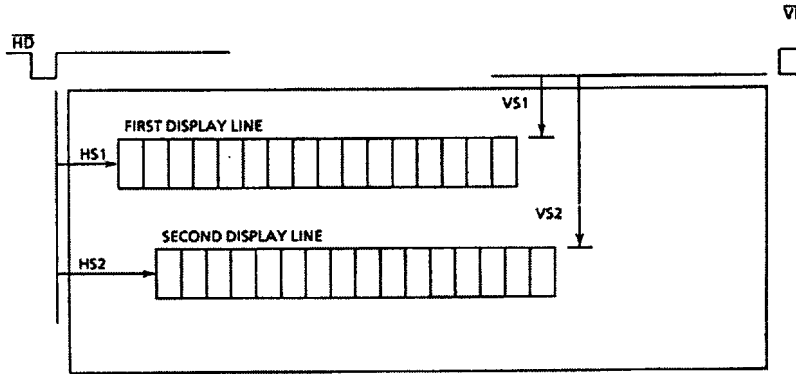

Figure 3-8. TV Screen Image

Table 3-5 Display Start Position

Symbol	Contents
HS10 to HS15	horizontal start position of the first display line $HS1 = ((32 \times HS15 + 16 \times HS14 + 8 \times HS13 + 4 \times HS12 + 2 \times HS11 + HS10) \times 4 + X) T_{OSC}$
VS10 to VS15	vertical start position of the first display line $VS1 = ((32 \times VS15 + 16 \times VS14 + 8 \times VS13 + 4 \times VS12 + 2 \times VS11 + VS10) \times 4 T_{HD}$
HS20 to HS25	horizontal start position of the second display line $HS2 = ((32 \times HS25 + 16 \times HS24 + 8 \times HS23 + 4 \times HS22 + 2 \times HS21 + HS20) \times 4 + X) T_{OSC}$
VS20 to VS25	vertical start position of the second display line $VS2 = ((32 \times VS25 + 16 \times VS24 + 8 \times VS23 + 4 \times VS22 + 2 \times VS21 + VS20) \times 4 T_{HD}$

Note. X: X is 17 when small character
 X is 34 when large character

- The vertical display positions of lines 1 and 2 can be specified in-

dependently but, to prevent overlapping of the two lines on the display, the value for the vertical display position of line 2 must satisfy $[VS2 > VS1 + CS11 \times 16T_{HD} + CS10 \times 32T_{HD}]$.

3.3.4 Control of OSD outputs buffer

The OSD outputs for Y, BL and RGB use tri-state output buffers for which the respective polarities can be inverted. Polarity

is controlled by DRC41 and tri-state is controlled by DRC51.

Bit 3 of DRC41 is used for controlling the smoothing function.

Table 3-6 Control of OSD Output

register	bit	symbol	output name	data "0"	data "1"
DRC41	3	ESMZ	---	smoozing OFF	smoozing ON
	2	---	---	---	---
	1	----	----	---	---
	0	DIV	DOUT1, DOUT0	active High	active Low
DRC51	3	----	----	---	---
	2	----	----	----	----
	1	EBF1	DOUT1	output buffer OFF	output buffer ON
	0	EBF0	DOUT0	output buffer OFF	output buffer ON

3.3.5 RA Port Function

R signal output and G signal output ports are also used as I/O ports. When not used for color signals, use is possible as normal

I/O ports. RA port and Y/BL selection is performed by OP0A.

Also, the upper 2 bits of IP0A are used to input the OSD display status.

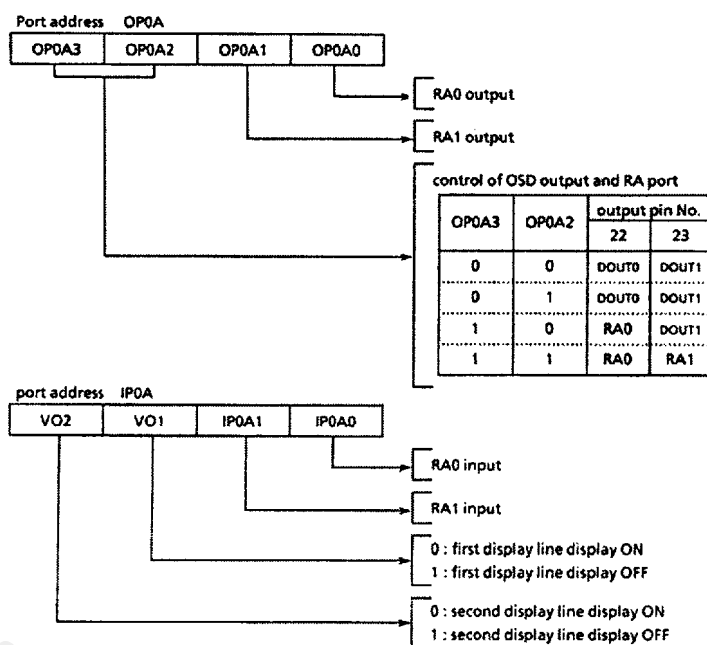

Figure 3-9. Port RA

3.3.6 Character ROM (Standard Characters)

Figure 3-10 shows the standard pattern characters and symbols available as character data. Character patterns can also

be set by the user. For details, refer to the section on piggy-back chip 47C034.

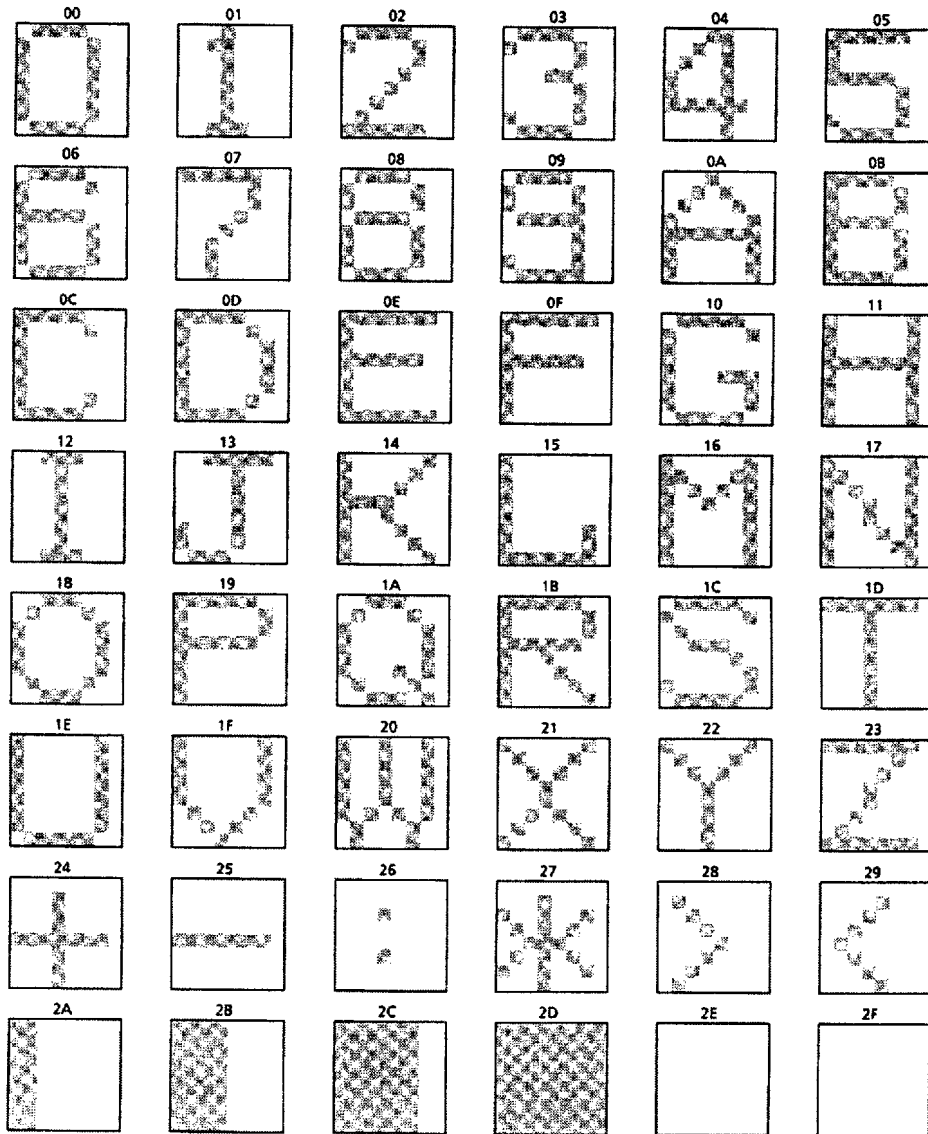

Figure 3-10. Character ROM Address and Character Pattern

3.4 4-Bit A/D Conversion (Comparator) Input

The comparator input is analog input to discriminate key input or AFC (Auto Frequency Control) signal. It's composed of 4-bit D/A converter, comparator and control circuit. Analog input level (CIN0 to CIN3) can be detected as 16-stage by setting reference voltage.

The comparator input can also be used as K0 port (digital input). To use as K0 port, set the most significant bit of the port address OP13 to "1". Which port is selected digital (K0) or comparator (CIN) input can be monitored by accessing the

port address IP13. DTB selector/status is also assigned to port address OP13/IP13.

Note. When the comparator input is selected, the comparator consumes typically 700μA current at VDD = 5V. To reduce the power consumption, K0 port should be set to digital input mode. In the HOLD mode, the comparator is automatically cut off by hardware. Further, during the slow operating mode, A/D conversion input is automatically disabled by hardware to reduce the power consumption.

3.4.1 Circuit Configuration of Comparator Input

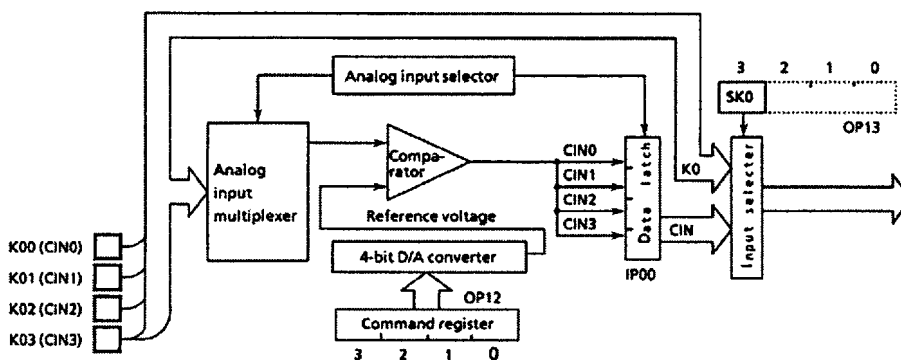

Figure 3-11. Circuit of Comparator Input

3.4.2 Control of Comparator Input

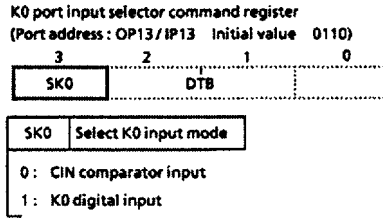

Figure 3-12. Command Register, Status Register

Reference voltage (Vref) is set by command register (port address OP12), and it is determined by the following form.

$$V_{REF} = V_{DD} \times (n + 1) / 16[V] \quad (n = 0 \text{ to } 15)$$

After initialization sequence, 4-channel comparator inputs continue comparison operation successively.

Since 2-instruction cycles are required to complete comparison of 1-channel, it is necessary to wait for 8-instruction cycles after setting a reference voltage to read data from the comparator. When analog input voltage is higher than reference voltage, comparator data latch is set to "1". At the initialization sequence, OP12 is set to "0". There is not latch when used to port K0.

Table 3-7 Reference Voltage

OP12				Vref. [V]
3	2	1	0	
0	0	0	0	0.31
0	0	0	1	0.62
0	0	1	0	0.94
0	0	1	1	1.25
0	1	0	0	1.56
0	1	0	1	1.87
0	1	1	0	2.19
0	1	1	1	2.50
1	0	0	0	2.81
1	0	0	1	3.12
1	0	1	0	3.44
1	0	1	1	3.75
1	1	0	0	4.06
1	1	0	1	4.37
1	1	1	0	4.69
1	1	1	1	5.00

3.5 D/A Converter (PWM) Output

The 47C430 have 2 channels built-in D/A converter (Pulse width Modulation) outputs. \overline{PWM} output can easily be obtained by connecting an external low pass filter.

\overline{PWM} outputs data are multiplex to the R4 port. When the R4 (\overline{PWM}) port is used for \overline{PWM} output, the corresponding bits of R4 output latch should be set to "1". The R4 output latch is initialized to "1" during reset.

\overline{PWM} output is controlled by the buffer selector (OP17) and the data transfer buffer (OP18). PWM data written to the data transfer buffer can be sent to the PWM data latch by writing "C_H" to the buffer selector, and \overline{PWM} output \overline{PWM} output. PWM data transferred to the PWM data latch remain intact until overwritten. Resetting and holding clear the buffer selector, data transfer buffer and PWM data latch to "0" (\overline{PWM} output is "H" level).

3.5.1 Configuration of Pulse Width Modulation Circuit

Configuration of pulse width modulation circuit shown in Figure 3-13.

3.5.2 Output Waveform of PWM Circuit

(1) $\overline{PWM0}$ output

$\overline{PWM0}$ is a PWM output controlled by 14 bits data. The basic period of the $\overline{PWM0}$ is $T_M = 2^{15}/fs$.

The higher 8 bits of 14 bits data are used to control the pulse width of the pulse output with the period of $T_S = T_M/64$, which is the sub - period of the $\overline{PWM0}$. When the 8 bits data are decimal n ($0 \geq n \geq 255$), this pulse width becomes $n \times t_0$, where $t_0 = 2/fc$.

The lower 6 bits of 14 bits data are used to control the generation of an additional t_0 wide pulse in each T_S period. When the 6 bits data are decimal m ($0 \geq m \geq 63$), the additional pulse is generated in each of m periods out of 64 periods contained in a T_M period. The relationship between the 6 bits data and the position of T_S period where the additional pulse is generated is shown in Table 3-8.

(2) $\overline{PWM1}$ output

$\overline{PWM1}$ is a PWM output controlled by 6 bits data. The period of them is $T_M = 2^7/fs$. When the 6 bits data are decimal k ($0 < k < 63$), the pulse width becomes $k \times t_0$. The waveform is also illustrated in Figure 3-13.

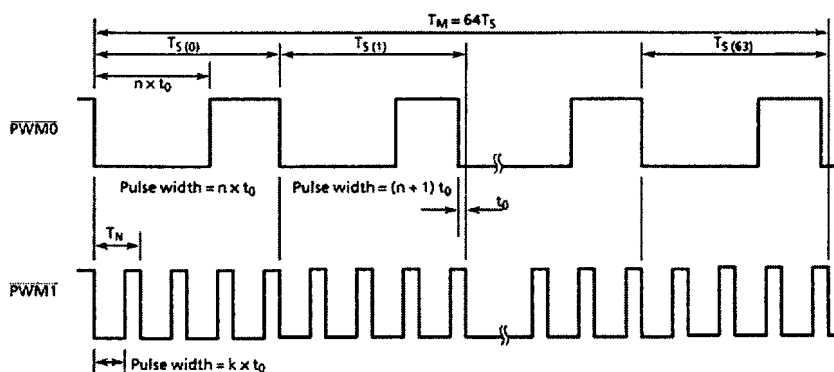

Figure 3-13. \overline{PWM} Output Waveform (It is Shown to the Additional Pulse $T_{S(1)}$ and $T_{S(63)}$ of the $\overline{PWM0}$)

Table 3-8 Correspondence Between 6 Bits Data and the Additional Pulse Generated T_S Periods

Bit position of 6 bits data	Relative position of T_S where the output pulse is generated (No. i of $T_{S(i)}$ is listed)
bit 0	32
bit 1	16, 48
bit 2	8, 24, 40, 56
bit3	4, 12, 20, 28, 36, 44, 52, 60
bit4	2, 6, 10, 14, 18, 22, 26, 30, —, 58, 62
bit5	1, 3, 5, 7, 9, 11, 13, 15, 17, —, 59, 61, 63

Note. When the corresponding bit is "1", it is output.

3.5.3 Control of PWM Circuit (Data Transfer)

PWM output is controlled by writing output data to a data transfer buffer (OP18). For writing, the output data are divided using the buffer selector (OP17). Buffer numbers are assigned to the data transfer buffers for these divided data, after which the data are written as shown in Table 3-9.

- ① The number of the transfer buffer to which the data are to be written is written to the buffer selector (OP17)
- ② The corresponding PWM data are written to the selected buffer (OP18).

③ Operations ① and ② are repeated, continuously writing data to the transfer buffer.

④ When all of the output data have been written. "C_H" is written to the buffer selector.

While the output data are being written to the transfer buffer, the previously written data are being output. For PWM0 output, switching to PWM output occurs at a maximum of $2^{15}/f_c$ [s] (at 4 MHz, 8192fs) after "C_H" is written to the buffer selector. For PWM1 output data switching, this requires $2^9/f_c$ [s] (at 4MHz, 128μs).

Table 3-9 Bit and Buffer Number of Data Transfer Buffer

Buffer Number (OP17)	Correspondence to bit (OP18)	Mode	PWM Output
2	Bit of PWM0 transfer buffer	Write	Preceding data
3	Bit of PWM0 transfer buffer	Write	Preceding data
4	Bit of PWM0 transfer buffer	Write	Preceding data
5	Bit of PWM0 transfer buffer	Write	Preceding data
6	Bit of PWM1 transfer buffer	Write	Preceding data
7	Bit of PWM1 transfer buffer	Write	Preceding data
C	None	Transfer	Present data

Input/Output Circuitry

The input/output circuitries of the 47C434A/634A control pins are shown below.

(1) Control pins

CONTROL PIN	I/O	CIRCUITRY	REMARKS
XIN XOUT	Input Output		Resonator connecting pins $R = 1\text{ k}\Omega$ (typ.) $R_f = 1.5\text{ M}\Omega$ (typ.) $R_o = 2\text{ k}\Omega$ (typ.)
RESET	Input		Hysteresis input Contained pull-up resistor $R_{IN} = 220\text{ k}\Omega$ (typ.) $R = 1\text{ k}\Omega$ (typ.)
HOLD (KE0)	Input (Input)		Hysteresis input (Sense input) $R = 1\text{ k}\Omega$ (typ.)
OSC1 OSC2	Input Output		Oscillation terminals for OSD $R = 1\text{ k}\Omega$ (typ.) $R_f = 1.5\text{ M}\Omega$ (typ.) $R_o = 2\text{ k}\Omega$ (typ.)
$\overline{\text{HD}}$ $\overline{\text{VD}}$	Input		Synchronous signal input Hysteresis input $R = 1\text{ k}\Omega$ (typ.)

www.DataSheet4U.com

(2) I/O ports

PORT	I/O	INPUT/OUTPUT CIRCUITRY and CODE			REMARKS
		PA, PG	PB	PC	
K0	Input				Pull-up or pull-down resistor $R_{IN} = 70\text{ k}\Omega$ (typ.) $R = 1\text{ k}\Omega$ (typ.)
R4 R7 RA	I/O				Tri-state Initial "Hi-Z" $R = 1\text{ k}\Omega$ (typ.)
R6	I/O				Sink open drain Initial "Hi-Z" $R = 1\text{ k}\Omega$ (typ.)
RB	I/O				Tri-state Initial "Hi-Z" Hysteresis input $R = 1\text{ k}\Omega$ (typ.)

www.DataSheet4U.com

Electrical Characteristics

Absolute Maximum Ratings ($V_{SS} = 0V$)

Parameter	Symbol	Pins	Ratings	Unit	
Supply Voltage	V_{DD}		-0.3 to 6.5	V	
Input Voltage	V_{IN}		-0.3 to $V_{DD} + 0.3$	V	
Output Voltage	V_{OUT}		-0.3 to $V_{DD} + 0.3$	V	
Output Current (Per 1 pin)	I_{OUT1}	R6 port	30	mA	
	I_{OUT2}	R7, R8, R9 port	3.2		
Output Current (Total)	ΣI_{OUT1}	R6 port	60	mA	
Power Dissipation	PD		DIP	300	mW
			SOP	180	
Soldering temperature (time)	T_{sld}		260 (10 s)	°C	
Storage Temperature	T_{stg}		-55 to 125	°C	
Operating Temperature	T_{opr}		-30 to 70	°C	

Recommended Operating Conditions ($V_{SS} = 0V$, $T_{opr} = -30$ to $70^{\circ}C$)

Parameter	Symbol	Pins	Conditions	Min.	Max.	Unit
Supply Voltage	V_{DD}		In the Normal mode	2.7	5.5	V
			In the HOLD mode	2.0		
High Input Voltage	V_{IH1}	Except Hysteresis Input	$V_{DD} \geq 4.5V$	$V_{DD} \times 0.7$	V_{DD}	V
	V_{IH2}	Hysteresis Input		$V_{DD} \times 0.75$		
	V_{IH3}			$V_{DD} < 4.5V$		
Low Input Voltage	V_{IL1}	Except Hysteresis Input	$V_{DD} \geq 4.5V$	0	$V_{DD} \times 0.3$	V
	V_{IL2}	Hysteresis Input			$V_{DD} \times 0.25$	
	V_{IL3}				$V_{DD} < 4.5V$	
Clock Frequency	f_c		$V_{DD} = 2.7$ to $5.5 V$	1	4.2	MHz
			$V_{DD} = 4.5$ to $5.5 V$	1	6.0	
	f_{OSD}			-	6.0	

Note. Input voltage V_{IH3} , V_{IL3} : in the HOLD operating mode.

DC Characteristics ($V_{SS} = 0V$, $T_{opr} = -30$ to $70^{\circ}C$)

Parameter	Symbol	Pins	Conditions	Min.	Typ.	Max.	Unit
Hysteresis Voltage	V_{HS}	Hysteresis Input		-	0.7	-	V
Input Current	I_{IN1}	K0 port, TEST, RESET, HOLD	$V_{DD} = 5.5V$, $V_{IN} = 5.5V/0V$	-	-	± 2	μA
	I_{IN2}	R port (open drain)					
Input Resistance	R_{IN1}	K0 port with pull-up/pull-down		30	70	150	$k\Omega$
	R_{IN2}	RESET		100	220	450	
Output Leakage Current	I_{LO1}	Tri-state R6, R8, R9 port (open drain)	$V_{DD} = 5.5V$, $V_{OUT} = 5.5V$	-	-	± 2	μA
Output High Voltage	V_{OH}	R port (tri-state)	$V_{DD} = 4.5V$, $I_{OH} = -0.7$ mA	4.1	-	-	V
Output Low Voltage	V_{OL}	R port (tri-state)	$V_{DD} = 4.5V$, $I_{OL} = 0.7$ mA	-	-	0.4	V
Output Level Low Current	I_{OL}	R6 port	$V_{DD} = 4.5V$, $V_{OL} = 1.0V$	-	20	-	mA
Supply Current (in the Normal mode)	I_{DD}		$V_{DD} = 5.5V$, $f_c = 4MHz$	-	2	4	mA
Supply Current (in the HOLD mode)	I_{DDH}		$V_{DD} = 5.5V$	-	0.5	10	μA

Note 1. Typ. values show those when $T_{opr} = 25^{\circ}C$, $V_{DD} = 5V$.

Note 2. Input Current I_{IN1} : The current through resistor is not included, when the pull-up/pull-down resistor is contained.

Note 3. Supply Current : $V_{IN} = 5.3V/0.2V$
The port K0 is opened when the pull-up/pull-down resistor is contained.
The voltage applied to the R port is within the valid range V_{IL} or V_{IH} .

A/D Conversion Characteristics

Parameter	Symbol	Pins	Conditions	Min.	Typ.	Max.	Unit
Analog Input Voltage	V_{AIN}	CIN		V_{SS}	-	V_{DD}	V
A/D conversion error				-	-	$\pm 1/4$	LSB

AC Characteristics ($V_{SS} = 0V, V_{DD} = 4.5$ to $6.0V, T_{opr} = -30$ to $70^{\circ}C$)

Parameter	Symbol	Conditions	Min.	Typ.	Max.	Unit
Instruction Cycle Time	t_{cy}		1.9	-	20	μs
High level clock pulse width	t_{WCH}	For external clock operation	80	-	-	ns
Low level clock pulse width	t_{WCL}					

Recommended Oscillating Conditions ($V_{SS} = 0V, V_{DD} = 4.5$ to $6.0V, T_{opr} = -30$ to $70^{\circ}C$)

- (1) 4MHz
Ceramic Resonator
CSA4.00MG (MURATA) $C_{XIN} = C_{XOUT} = 30pF$
KBR-4.00MS (KYOCERA) $C_{XIN} = C_{XOUT} = 30pF$
Crystal Oscillator
204B-6F 4.0000 (TOYOCOM) $C_{XIN} = C_{XOUT} = 20pF$
- (2) 6MHz
LC Resonator
TBEKSES-30361FBY (TOKO)

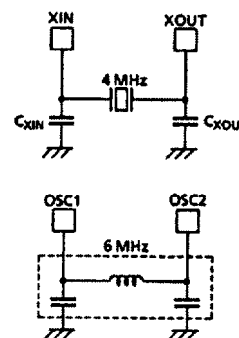

Note: An electrical shield by metal plate on the surface of the IC package should be recommendable in order to prevent the device from the high electric field stress applied from CRT (Cathode Ray Tube) for continuous reliable operation.

Typical Characteristics

