



TMPA 8859 SERVICE MANUAL

CONTENT

(1) General-----	1
(2) Frame Chart-----	fig.1
(3) IC Function Introduction -----	1
3.1 N501 TMPA8859-----	2
3.2 N001 TC90L01N -----	3
3.3 N301 TDA8172 -----	4
3.4 N601 TA1343N-----	4
3.5 N602 TA8246N-----	4
(4) I ² C Bus Control -----	5
4.1 Menu Entry -----	5
4.2 Item Introduction -----	5
(5) IC Voltage -----	8
(6) Trouble shorting-----	9

Modelos:

TVS-2542M(SCL)
TVS-2545PF(SCL)
TVS-2944M(SCL)
TVS-2945PF(SCL)
TVS-3444M(SCL)
TVS-3445PF(SCL)

(1) General

This chassis consists of main IC TMPA8859, TA1343N, TC90L01N. TMPA8859 is an integrated circuit for a PAL/NTSC TV. A MCU and a TV signal processor (SP) are integrated in a 64-pin shrink DIP package. The MCU contains 8-bit CPU,ROM,RAM,I/O ports,timer/counters, A/D converters,an on-screen display controller,remoter control interfaces,IIC bus interfaces. The TV signal processor contains PIF,SIF,Video,multi-standard chroma,Sync,RGB processors.

(2) Frame Chart (see fig.1)

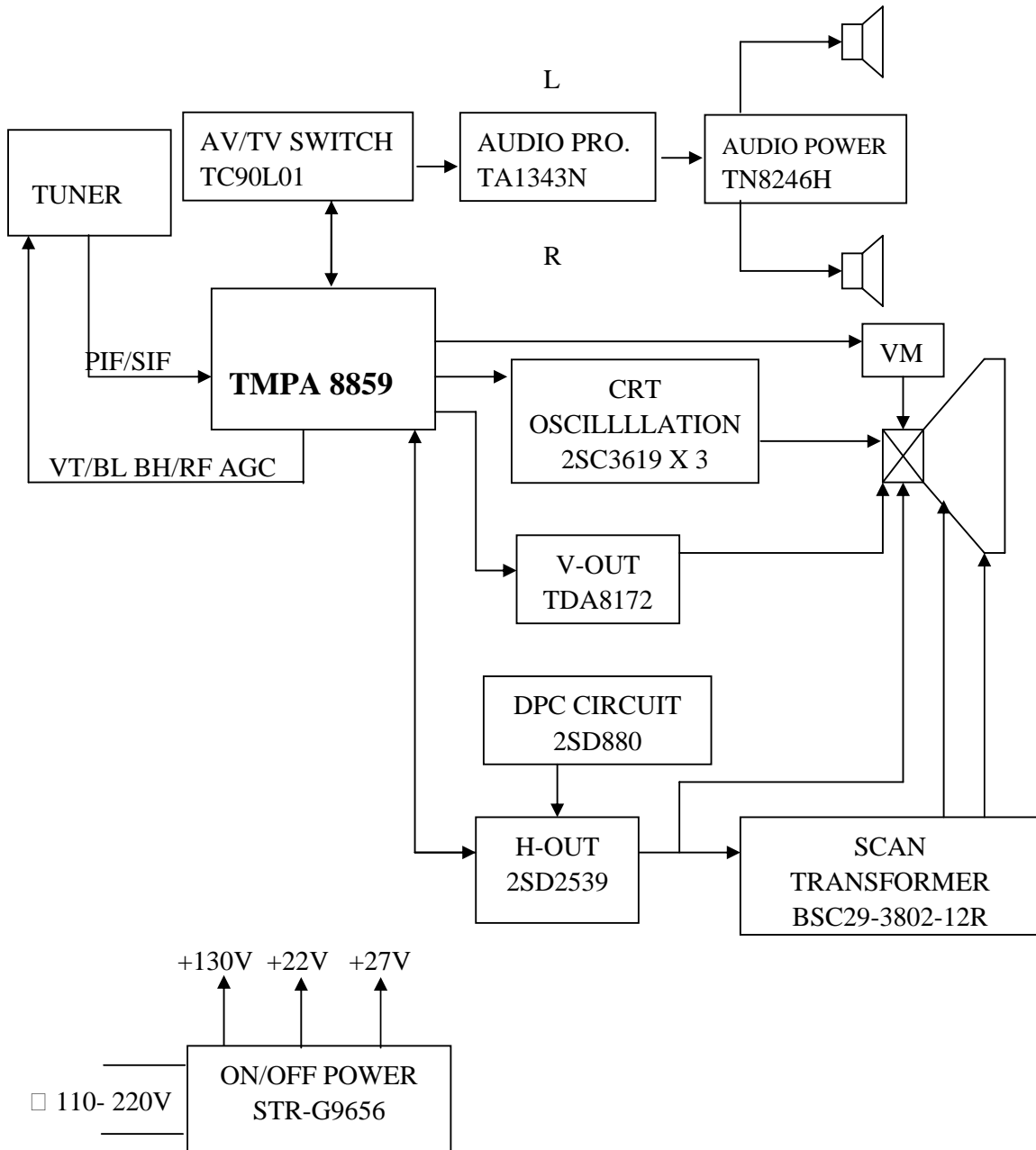

fig.1

(3) IC Function Introduction

3.1 N501 TMPA8859 Function: MCU and SP

Icon	PIN	Description
SDA2	1	IIC bus serial data input/output
X-RAY	2	X-ray Output
KEY	3	Key input
DVSS	4	GND connection
RESET	5	Reset signal input
XOUT	6	8 MHz oscillator connection
XIN	7	8 MHz oscillator connection
TEST	8	GND connection
DVDD	9	5V power supply
VVSS	10	GND connection
TV GND	11	GND terminal for Analog block
FBP IN	12	Input terminal for FBP
H.OUT	13	Horizontal driving pulse output
H.AFC1	14	H AFC filter connection
V.SAW	15	Terminal to be connected capacitor to generate V saw signal
V.OUT	16	Vertical driving pulse output
H.Vcc(9V)	17	Vcc terminal for DEF circuit
Ys	18	Ys IN
Cb in	19	Input terminal for Cb signal
Y in	20	Input terminal for Y signal
Cr in	21	Input terminal for Cr signal
DIG GND	22	GND terminal for Digital block
C in	23	Input terminal for Chroma signal
V2 in	24	Input terminal for Video signal
DIG Vdd	25	Vcc terminal for Digital block
CW out	26	Output terminal for fsc wave signal
ABCL in	27	Input terminal for ABL/ACL control
EW out	28	Output terminal for east-west correction singal
IF Vvv(9V)	29	Vcc terminal for IF circuit
TV out	30	Detected PIF signal output terminal
SIF out	31	Detected SIF signal output terminal
EHT in	32	
H.COTT in	33	
DC NF	34	Terminal to be connected capacitor for DC Negative feedback
PIF PLL	35	Loop filter for PIF PLL connection
IF Vvv(5V)	36	Vcc terminal for IF circuit
REG FIL	37	Terminal to be connected capacitor for stabilizing internal bias
DE-EMP	38	Terminal to be connected capacitor for SIF Det De-Emphasis
IF AGC	39	IF AGC filter connection

IF GND	40	GND terminal for IF circuit
IF IN	41	Input terminals for IF signals
IF IN	42	Input terminals for IF signals
RF AGC	43	RF AGC control level output
YC Vcc	44	Vcc terminal for Y/C circuit
Vsm out	45	Output terminal for Vsm signal
Black DET	46	Terminal to be connected with Black Det filter for black stretch
APC Filter	47	Terminal to be connected with APC filter for Chroma demodulation
IK IN	48	Sense ACB cathode current input
RGB Vcc	49	Vcc terminal for RGB circuit
R OUT	50	Output terminal for R signal
G OUT	51	Output terminal for G signal
B OUT	52	Output terminal for B signal
TV GND	53	GND terminal for Analog block
A GND	54	GND connection
A VDD	55	5V power supply
MUTE	56	
SDA1	57	IIC bus serial data input/output
SCL1	58	IIC bus serial clock input
PWM	59	
LED	60	
SCL2	61	IIC bus serial clock input
SYNC	62	Horizontal sync signal input
REMOTE	63	Remote controller signal input
POWER	64	Power control (On=Hi. Off=L)

3.2 N001 TC90L01N Function: I²C bus control , Audio/Video switching IC

Name	Pin	Function
Lin TV	1	This pin is for input a left audio signal form the main demodulator in the TV
Vin TV	2	This pin is for input a composite video signal form the main demodulator in the TV
Rin TV	3	This pin is for input a right audio signal form the main demodulator in the TV
V/Yin V1	4	This pin is for input a luminance signal or composite video signal from an external source(V1 channel)
LinV1	5	This pin is for input a left audio signal from an external source(V1 channel)
CinS1	6	This pin is for input a chroma signal from an external source(S1 channel)
RinV1	7	This pin is for input a right audio signal from an external source(V1 channel)
VinV2	8	This pin is for input a composite video signal from an external source(V2 channel)
LinV2	9	This pin is for input a left audio signal from an external source(V2 channel)
ALC	10	This is an detect output pin of ALC(Auto Level Control)
RinV2	11	This pin is for input a right audio signal from an external source(V2 channel)
Vcc	12	This is the power supply pin. Apply 9V to this pin.
SDA	13	This is an IIC bus data input/output pin.
SCL	14	This is an IIC bus clock input pin.
GND	15	This is the GND pin.
Rout TV	16	This pin is for output right audio signal.

Lout TV	17	This pin is for output left audio signal.
Yout	18	This pin is for output luminance signal.
BAND2	19	This pin is for output band2 to control tuner.
Cout	20	This pin is for output chroma signal.
BAND1	21	This pin is for output band1 to control tuner.
Vout	22	This pin is for output main channel composite video signal.
Rout Mon	23	This pin is for monitor-output right audio signal.
Lout Mon	24	This pin is for monitor-output left audio signal.

3.3 N301 TDA8172 **Function:** V-scan output

PIN	FUNCTION
1	Inverting input
2	Supply voltage
3	Flyback generator
4	Ground
5	Output
6	Output stage supply
7	Non- Inverting input

3.4 N601 TA1343N **Function:**TV sound processor

Name	Pin	Function
Offset canceling filter	1	DC offset canceling filter for bass boost.
$\phi 4-\phi 1$	2-5	Terminals for capacitors of the phase shift blocks.
Lch input	6	Audio input terminal.
GND	7	GND terminal.
Rch input	8	Audio input terminal.
Bias filter	9	Filter for noise rejection of the bias.
Bass LPF(R)	10	LPF for bass control circuits.
Treble HPF(R)	11	HPF for treble control circuits.
Wch output	12	Woofer audio output terminal.
Rch output	13	Right audio output terminal.
Treble HPF(L)	14	HPF for treble control circuits.
Bass LPF(L)	15	LPF for bass control circuits.
Lch output	16	Left audio output terminal.
Woofer LPF1	17	LPF for bass boost circuit.
Woofer LPF2	18	LPF for bass boost circuit.
Woofer LPF3	19	LPF for bass boost circuit.
Vcc	20	This is the power supply pin. Apply 9V to this pin.
Volume filter	21	Smoothing filter for volume control
Woofer LPF	22	Smoothing filter for bass boost control
SCL	23	This is an IIC bus clock input pin.
SDA	24	This is an IIC bus data input/output pin.

3.5 N602 TA8246 Function: Audio power amplifier

Name	Pin	Function
NC	1	
IN2	2	Audio signal input2.
Pre-GND	3	GND terminal.
IN1	4	Audio signal input1.
MUTE.SW	5	Mute control terminal.
RF	6	Ripple filter terminal.
MUTE. T.C.	7	Mute control terminal.
OUT1	8	Audio signal output1.
Vcc	9	This is the power supply pin
PW-GND	10	GND terminal.
NC	11	
OUT2	12	Audio signal output2.

(4) I²C Bus Control

4.1 Menu Entry

Press “D” button on the factory remote control to enter the “D” mode, the letter “D” will be displayed at the upper right coner and the adjusting items will be displayed at the upper left coner.

Press the channel +/- to select the preferred item; press the volume +/- to adjust the value of each item.

4.2 Item introduction

TMPA8859 BUS DATA

No	S	D	item	Comment		
1	S	D1	RCUT	R CUTOFF	20	
2	S	D1	GCUT	G CUTOFF	20	
3	S	D1	BCUT	B CUTOFF	20	
4	S	D1	GDRV	G DRIVE	40	
5	S	D1	BDRV	B DRIVE	40	
6		D1	CNTX	SUB CONTRAST MAX	7F	
7	S	D1	BRTC	SUB BRIGHT CEN	50	
8	S	D1	COLC	NTSC SUB COLOR CEN	40	
9	S	D1	TNTC	SUB TINT CEN	40	
10	S	D1	COLP	PAL SUB COLOR CEN(difference)	00	
11		D1	COLS	SECAM SUB COLOR CEN	40	
12	S	D1	SCOL	SUB COLOR CENTER for DVD	07	
13		D1	SCNT	SUB CONTRAST	0D	
14		D1	CNTC	SUB CONTRAST CEN	30	
15		D1	CNTN	SUB CONTRAST MIN	02	
16		D1	BRTX	SUB BRIGHT MAX	20	
17		D1	BRTN	SUB BRIGHT MIN	30	
18		D1	COLX	SUB COLOR MAX	3F	

19		D1	COLN	SUB COLOR MIN	00
20		D1	TNTX	SUB TINT MAX	3F
21		D1	TNTN	SUB TINT MIN	3F
22		D1	ST3	NTSC SHARP CEN (TV)	28
23		D1	SV3	NTSC SHARP CEN (AV)	28
24		D1	ST4	OTHER SHARP CEN (TV)	28
25		D1	SV4	OTHER SHARP CEN (AV)	28
26		D1	SVD	SHARP CENTER in DVD	28
27		D1	ASSH	ASYMMETRY-SHARPNESS	04
28		D1	SHPX	SUB SHARP MAX(difference)	3F
29		D1	SHPN	SUB SHARP MIN(difference)	12
30		D1	TXCX	UV COLOR MAX	1F
31		D1	RGCN	UV COLOR MIN	1F
32		D1	ABL	ABL data	35
33		D1	DCBS	A part of video data	14
34		D1	CLTM	The data when TV mode	28
35		D1	CLVO	The data when AV mode	2F
36		D1	CLVD	The data when DVD mode	40
37		D1	DEF		01
38		D1	AKB		00
39		D1	R SNS	R SENSE	00
40		D1	G SNS	G SENSE	00
41		D1	B SNS	B SENSE	00
42	S	D1	HPOS	60Hz H-position	0C
43	S	D1	VP50	50Hz V-position	04
44	S	D1	HIT	60Hz Vertical size	15
45		D1	HPS	50Hz H-position(D)	02
46		D1	VP60	60Hz Vertical phase	02
47		D1	HITS	50Hz Vertical size	FF
48	S	D1	VLIN	60Hz V-LINEARITY	0F
49		D1	VSC	V-S CORRECTION	07
50		D1	VLIS	50Hz V-LINEARITY(D)	FF
51		D1	DPC	60Hz E-W PARABOLA	0C
52		D1	DPCS	50Hz E-W PARABOLA(dif)	00
53		D1	KEY	60Hz TRAPEZIUM	21
54		D1	KEYS	50Hz TRAPEZIUM(D)	00
55		D1	WID	60Hz PICTURE WIDTH	1B
56		D1	WIDS	50Hz PICTURE WIDTH(dif)	00
57		D1	CNRT	EW cornet corr	08
58		D1	CNRB	EW cornet corr	09
59		D1	VEHT	V-COMPENSATI	06
60		D1	HEHT	H-COMPENSATI	01
61		D1	VSS	Shift data of 50Hz/60Hz	00
62		D1	BRTS	SUB BRIGHT(D)	00
63	S	D1	RAGC	RF AGC	28
64		D1	HAFC	HAFC GAIN	09

65		D1	AGCC	AGCC(Nouse)	
66		D1	FLG0	Flags for IF	52
67		D1	FLG1	FLAGS	05
68		D1	REFP	REF Pulse Position	00
69		D1	STBY		00
70		D1	SVM	SVM data	06
71		D1	BLK		00
72		D1	VCEN	V Centering	10
73		D1	HITL1	HIT offset for zoom1	04
74		D1	HITL2	HIT offset for zoom2	08
75		D1	HITL3	HIT offset for zoom3	0C
76		D1	DPCL1	DPC offset for zoom1	01
77		D1	DPCL2	DPC offset for zoom2	02
78		D1	DPCL3	DPC offset for zoom3	04
79		D1	MOD	MODE	03
80		D1	UCOM	Chroma APC Setting	60
81		D1	MODE3	Video mute setting	80
82		D1	NOIS	HAFC control	01
83		D1	SYCT		08
84		D1	VTST		00
85		D1	PYNX	H.SYNC MAX in normal condition	28
86		D1	PYNN	H.SYNC MIN in normal condition	18
87		D1	PYXS	H.SYNC MAX in search condition	22
88		D1	PYNS	H.SYNC MIN in search condition	1E
89		D1	ONTM		00
90		D1	NSHP		10
91		D1	V01A	VOLUME 1%	09
92		D1	V25A	VOLUME 25%	24
93		D1	V50A	VOLUME 50%	40
94		D1	V100A	VOLUME 100%	60
95		D1	VMUTE2	Half mute volume setting	14
96		D1	WCTL	APRO mode data	41
97		D1	SUR1	MONO Surround MODE	06
98		D1	SUR2	STORE 1 Surround MODE	0C
99		D1	SUR3	STORE2 Surround MODE	0F
100		D1	BASC	BASS Center	40
101		D1	BASX	BASS MAX	72
102		D1	TREC	TREBLE Center	42
103		D1	BALC	BALANCE Center	40
104		D1	WOFC	WOOFER Center	40
105		D1	BAS1	BASS data in MEMORY 1	CB
106		D1	BAS2	BASS data in MEMORY 2	3C
107		D1	BAS3	BASS data in MEMORY 3	CB
108		D1	TRE1	TREBLE data in MEMORY 1	55
109		D1	TRE2	TREBLE data in MEMORY 2	37
110		D1	TRE3	TREBLE data in MEMORY 3	A8

111		D1	WFL1	Woofers data in MEMORY 1	CB	
112		D1	WFL2	Woofers data in MEMORY 2	99	
113		D1	WFL3	Woofers data in MEMORY 3	E4	
114		D1	WON1	WOOFER ON coefficient	05	
115		D1	WON2	WOOFER ON coefficient	09	
116		D1	WOFF	WOFFER out level when Woofer off	00	
117		D1	AUCON1	Stereo/SAP noise threshold	AA	
118		D1	AUCON2	Level adjust setting	02	
119		D1	AUALI1	For wideband expander	00	
120		D1	AUALI2	For spectral expander	00	
121		D1	AUTIM	Timing current alignment data	00	
122		D1	AUSTP	Audio step	01	
123		D1	VPCT	X-ray protection counter	02	
124		D1	TUNR	Select tuner	00	
125		D1	CCDOSD		22	
126		D1	ccDOSDF		59	
127		D1	OSDF		65	
128		D1	OSD		2E	
129		D1	PDOPT0	PANDA OPTION0	F1	
130		D1	PDOPT1	PANDA OPTION1	00	
131		D1	Waittime	V-MUTE when POWER ON	58	
132		D1	CUR CEN	CENTER OF SCREEN OPEN	CA	
133		D1	CUR STEP	STEP OF SCREEN OPEN	02	
134		D1	PWR	Self check data	00	
135		D1	BUS	Self check data	00	
136		D1	MEM	Self check data	00	
137		D1	OPT	Optional setting	9F	
138		D1	OPTM1	Optional setting	A2	
139		D1	OPTM2	Optional setting	00	
140		D1	OPTM3	Optional setting	C3	
141		D1	OPTM4	Optional setting	04	
142		D1	CATVSEL		00	

Note: the bold date cannot be changed

(5) IC voltage

N507 TMPA8859

PIN	1	2	3	4	5	6	7	8	9	10	11	12	13
Voltage	/	/	/	0	5	2.4	2.3	0	5	0	0	1.1	1.9
PIN	14	15	16	17	18	19	20	21	22	23	24	25	26
Voltage	6.6	4.2	4.7	9	/	2.5	2.5	2.5	0	2.5	2.5	3.3	/
PIN	27	28	29	30	31	32	33	34	35	36	37	38	39
Voltage	4.9	4.6	9	5.1	1.8	4.1	3	2.3	2.4	5	2.2	4.4	4.2
PIN	40	41	42	43	44	45	46	47	48	49	50	51	52
Voltage	0	0	0	4.5	2.7	2.7	1.9	2.6	0	9	2.5	2.5	2.5
PIN	53	54	55	56	57	58	59	60	61	62	63	64	
Voltage	0	0	5	/	4.8	4.8	/	/	/	4.4	2.5	/	

N001 TC90L01

PIN	1	2	3	4	5	6	7	8	9	10	11	12	13
Voltage	4.5	4.5	4.5	4.5	4.5	4.5	4.5	4.5	4.5	5	4.5	9	/
PIN	14	15	16	17	18	19	20	21	22	23	24		
Voltage	/	0	4.5	4.5	4.5	/	4.5	/	4.5	4.5	4.5		

N301 TDA8172

PIN	1	2	3	4	5	6	7
Voltage	2.7	26.2	1.4	0	14	26.5	2.7

N601 TA1343N

PIN	1	2	3	4	5	6	7	8	9	10	11	12	13
Voltage	4.5	4.5	4.5	4.5	4.5	4.5	0	4.5	5.7	4.5	4.5	4.5	4.5
PIN	14	15	16	17	18	19	20	21	22	23	24		
Voltage	4.5	4.5	4.5	5.1	5.1	5.1	9	0	1.5	/	/		

N602 TA8246N

PIN	1	2	3	4	5	6	7	8	9	10	11	12
Voltage	/	2.1	0	2.1	2.4	7.4	0	11	22	11	/	11

(6). Trouble shorting

T803

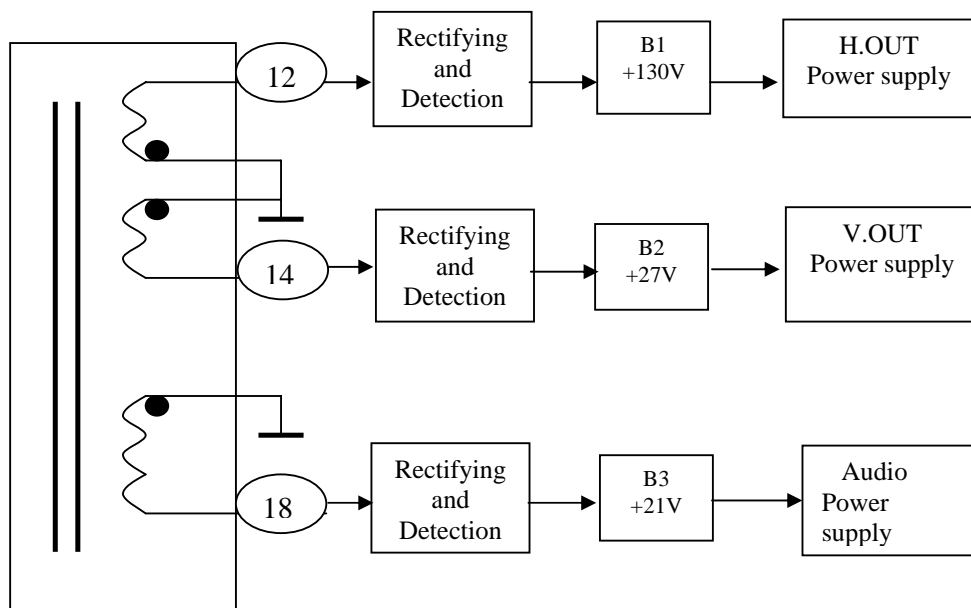

Power supply outline

6.1 No grating, no picture, no sound

General, these failures are produced by power sources, because of which refer to a wider area, so that can be divided them two conditions to explain: no B1 130 V and existing B1 130V.

(1) No B1 (130 V) voltage (voltage of network 220 V ac)

These failures may be caused by power supply switch.

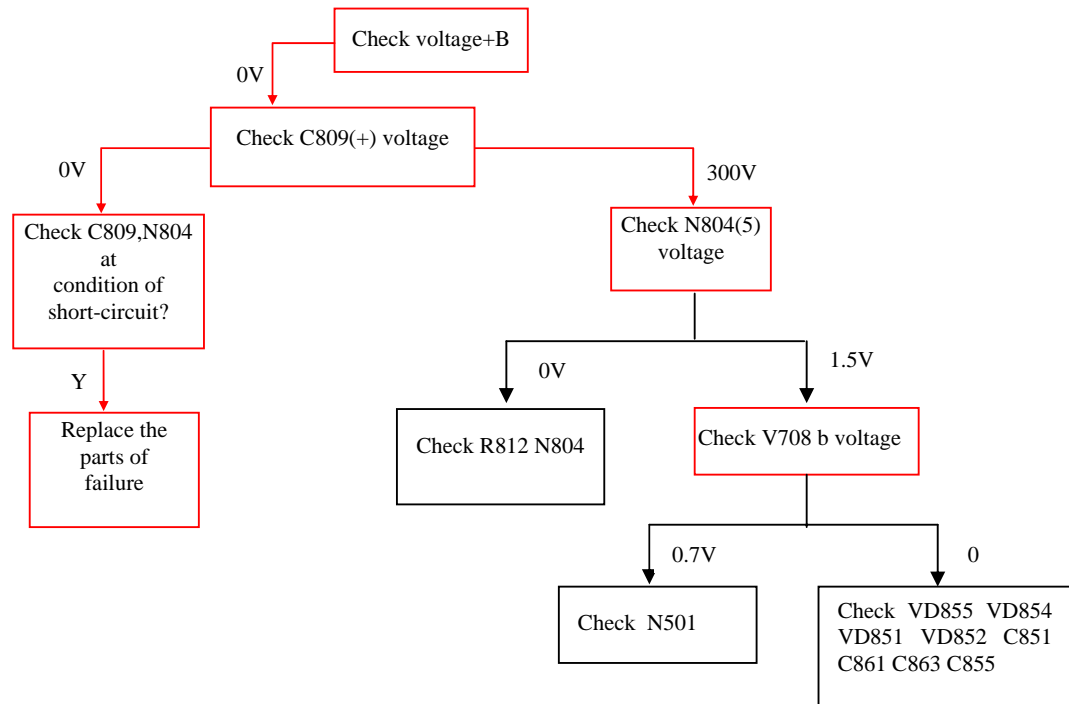

(2) Existing B1 130 V

These failures may be caused by abnormal operation of horizontal scan, to confirm which can observe the filament of tube whether bright on. If determined horizontal scan in abnormal operation, look for the failure start from the horizontal drive stage. Search upward to TMPA8859 with method of checking DC voltage and waveform according to sequence: PIN13/H.OUT port→ PIN17 power supply→ V707/9V output.

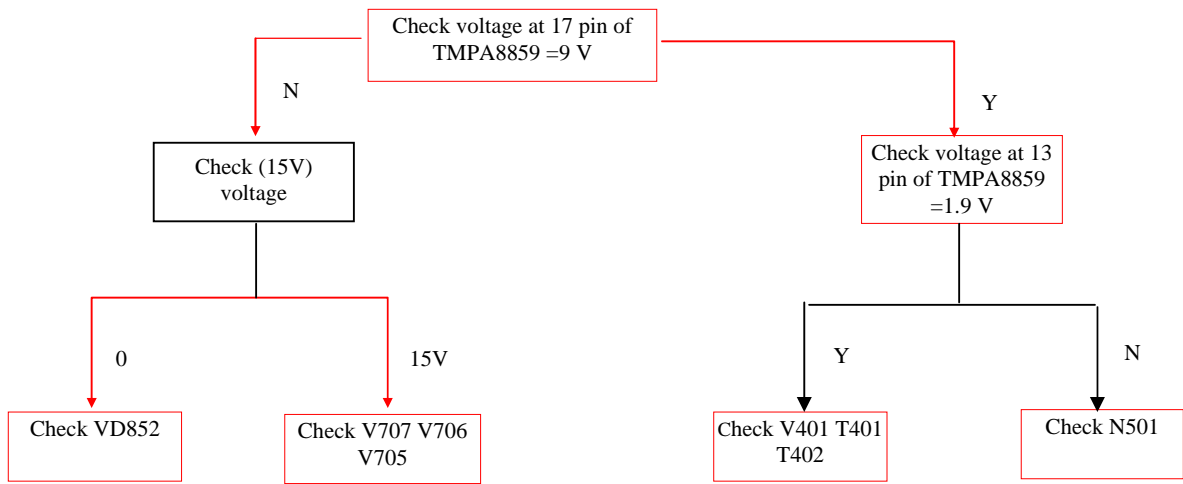

6.2 Existing grating and no picture

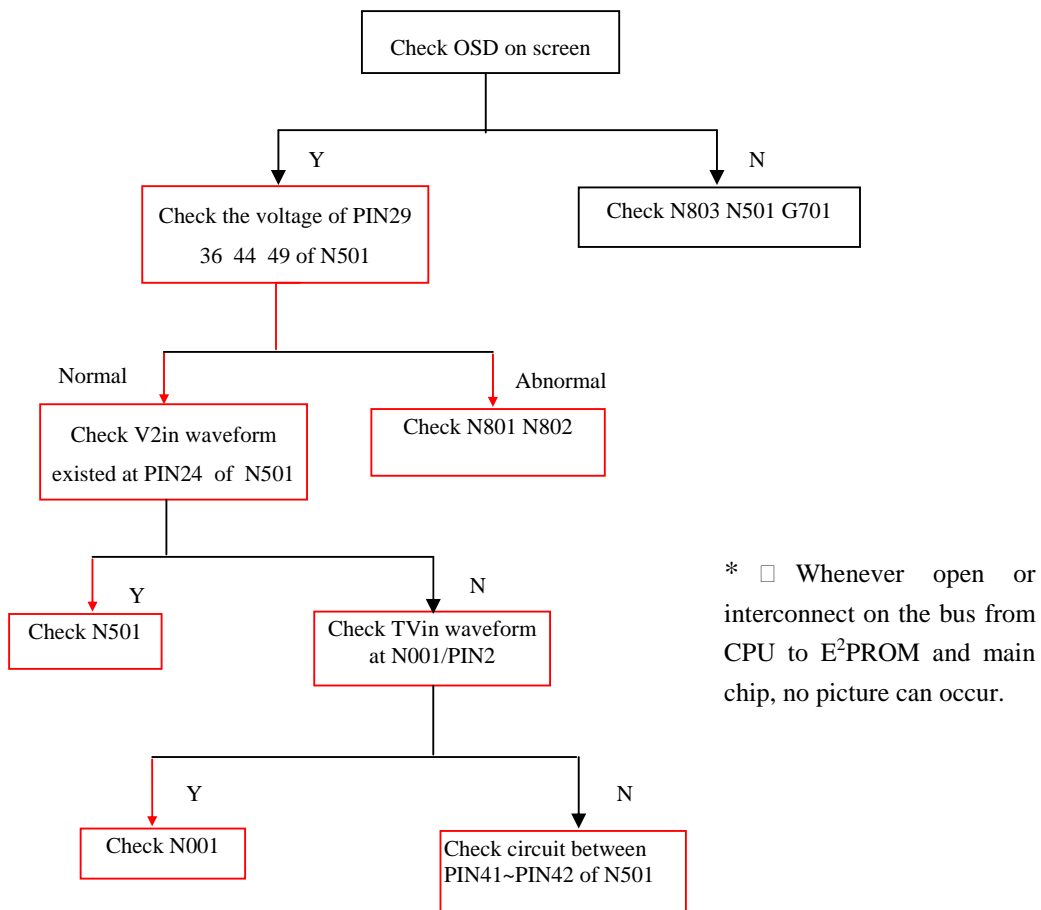

6.3 Existing grating and picture, no sound

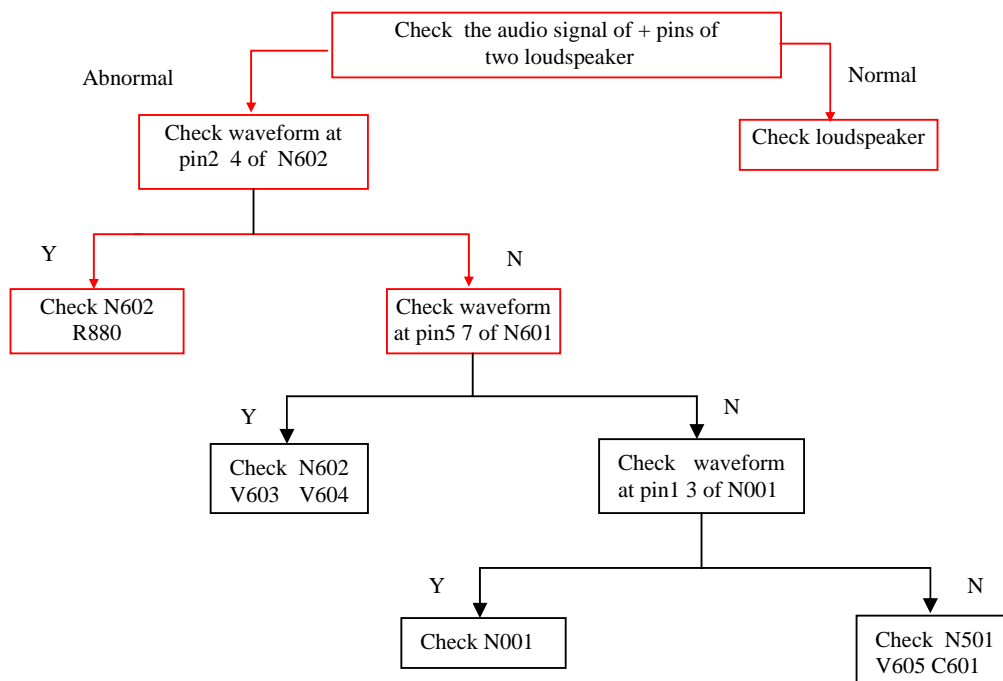

6.4 Cannot save channels

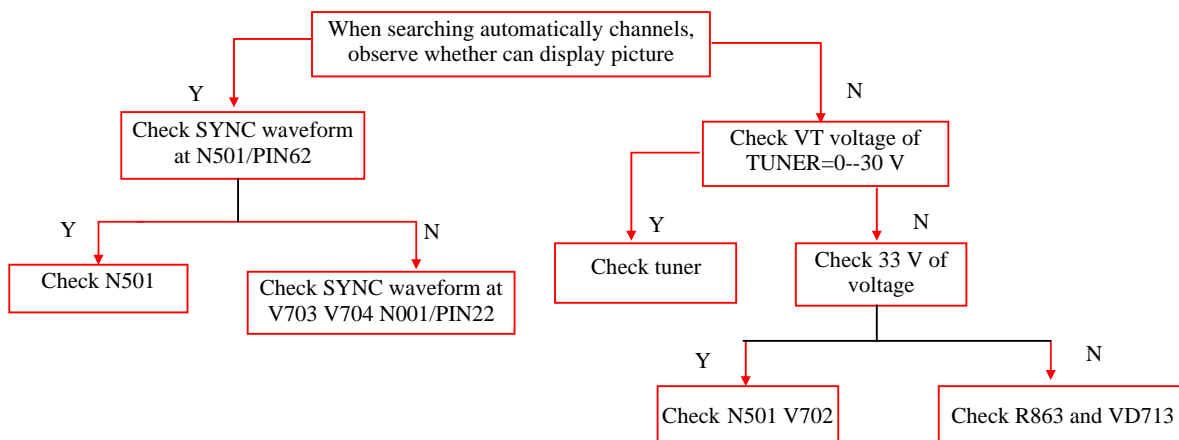

6.5 CPU non-operating

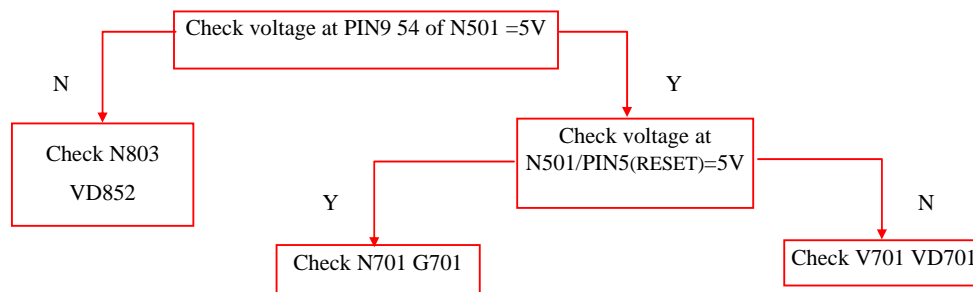

Circuit Diagram of TMPA8829-E-KD Color TV Receiver

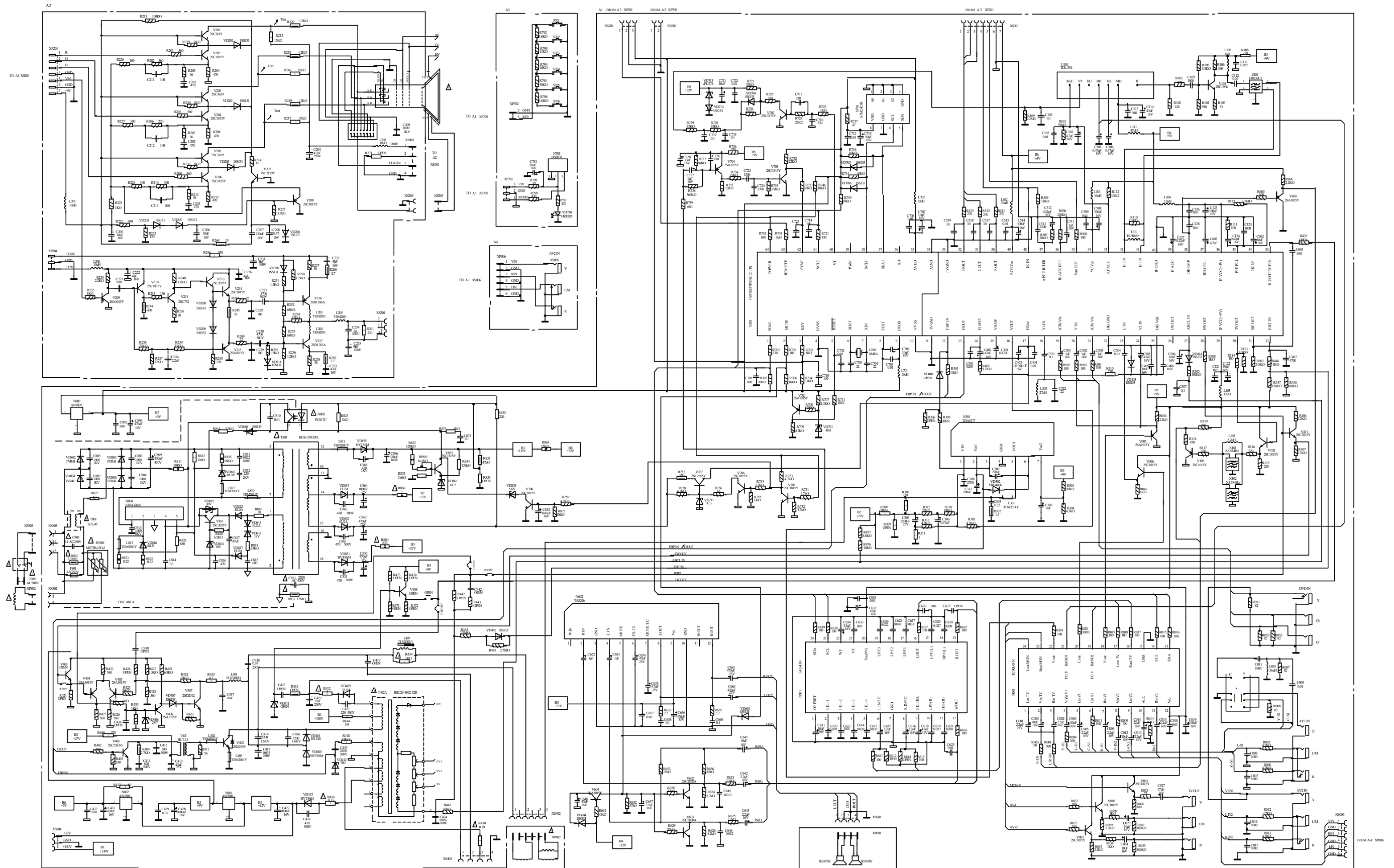

This diagram is only for reference