



TMR1262

Nano-Ampere TMR Bipolar Switch

General Description

The TMR1262 is a 200nA ultra-low power magnetic switch sensor. It is a digital bipolar magnetic switch that integrates TMR and CMOS technology in order to provide a magnetically triggered digital switch with high sensitivity, high speed, and ultra-low power consumption. It integrates a push-pull half-bridge TMR magnetic sensor and CMOS signal processing circuitry within the same package. Designed for use in applications that are both power-critical and performance-demanding, this device includes an on-chip TMR voltage generator for precise magnetic sensing, TMR voltage amplifier and comparator, a Schmitt trigger to provide switching hysteresis for noise rejection, and CMOS push-pull output. An internal band gap regulator is used to provide temperature compensated supply voltage for internal circuits, and it allows a wide range of operating supply voltages. The TMR1262 features ultra-low power consumption at 200nA with a fast internal switching frequency at 50Hz. Other important features include accurate switching points, excellent thermal stability, and a wide range of supply voltages. It is available in two packaging form factors: SOT23-3 (P/N TMR1262S), or TO-92S (P/N TMR1262T).

Features and Benefits

- Tunneling Magnetoresistance (TMR) Technology
- Nano-Ampere Ultra-low Power Consumption at 200nA
- Fast Internal Switching Frequency at 50Hz
- Bipolar Operation with High Sensitivity
- Operating Temperature Range from -40°C to 125°C
- Wide Range of Supply Voltages from 1.8V to 5.5V
- CMOS Output



TMR1262S (Left), TMR1262T (Right)

Applications

- Utility Meters including Water, Gas, and Heat Meters
- Solid State Switches
- Speed Sensing
- Rotary and Linear Position Sensing

Block Diagram

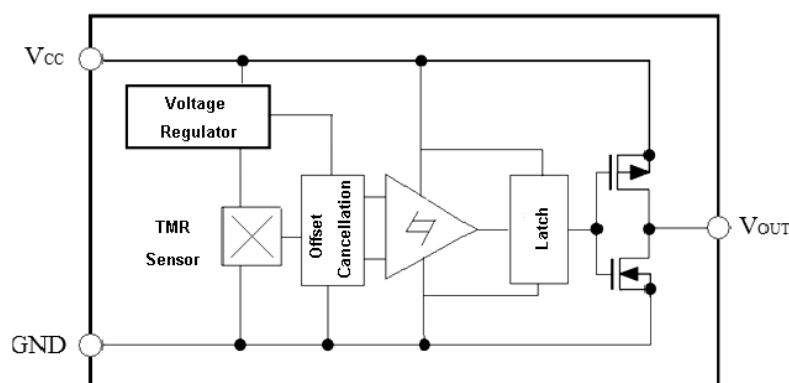

Pin Configuration

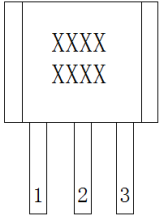

TO-92S

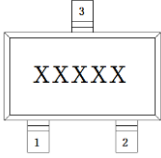

SOT23-3

Pin Name	Pin No.		Pin Function
	TO-92S	SOT23-3	
V _{OUT}	1	2	Output
GND	2	3	Ground
V _{CC}	3	1	Supply Voltage

Absolute Maximum Ratings

Characteristic	Symbol	Rating	Units
Supply Voltage	V _{CC}	7	V
Reverse Supply Voltage	V _{RCC}	0.3	V
Output Current	I _{OUTSINK}	9	mA
Magnetic Flux Density	B	4000	G
ESD Level (HBM)	V _{ESD}	4	kV
Operating Ambient Temperature	T _A	-40~125	°C
Storage Temperature	T _{stg}	-50~150	°C

Electrical Characteristics (V_{CC}=3.0V, T_A=25°C)

Characteristic	Symbol	Test Conditions	Min.	Typ.	Max.	Units
Supply Voltage	V _{CC}	Operating	1.8	3.0	5.5	V
Output High Voltage	V _{OH}		V _{CC} -0.3		V _{CC}	V
Output Low Voltage	V _{OL}		0		0.2	V
Supply Current	I _{CC}	Output open circuit		200		nA
Switching Frequency	F			50		Hz

Note: A 0.1μF capacitor is connected between VCC and GND during all tests in the table above.

Magnetic Characteristics (V_{CC} = 3.0V, T_A = 25°C)

Characteristic	Symbol	Min.	Typ.	Max.	Units
Operate Point	B _{OP}		17		G
Release Point	B _{RP}		-17		G
Hysteresis	B _H		34		G

Voltage and Temperature Characteristics

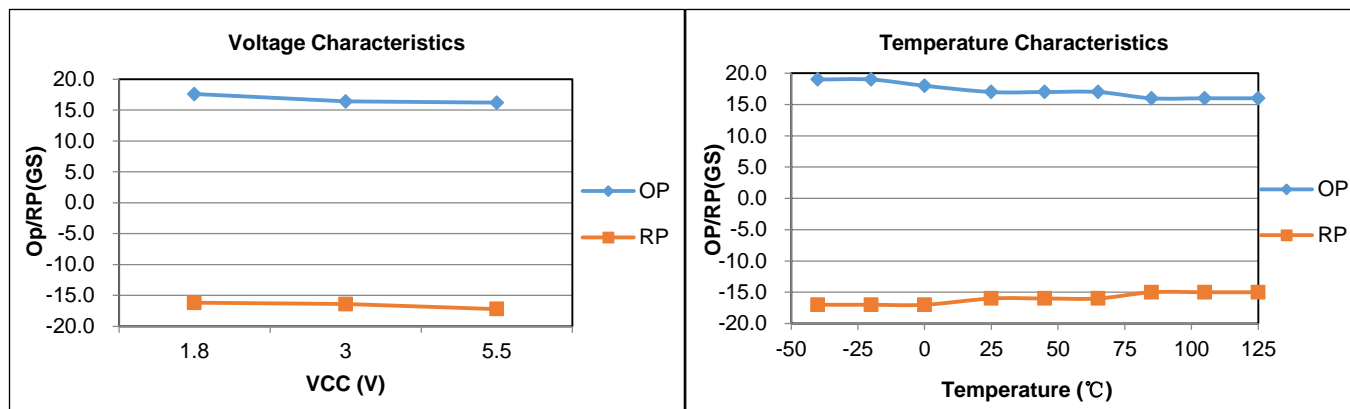

Output Behavior vs. Magnetic Polarity

Magnetic Polarity	Test Conditions	Output
South	$B > B_{OP}$	Low (On)
North	$B < B_{OP}$	High (Off)

Note: when power is turned on under zero magnetic field, the output is "High".

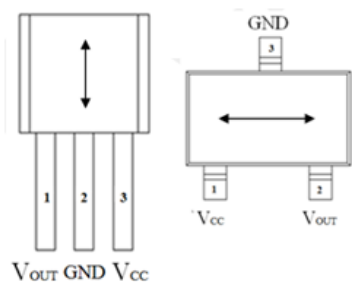

Sensing Direction

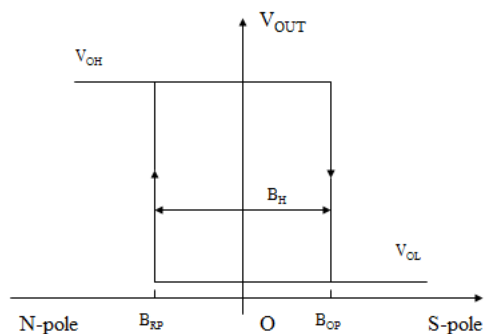

Switching Behavior of TMR1262

Application Information

The output of the TMR1262 switches low (turns on) when a magnetic field parallel to the TMR sensor exceeds the operate point threshold, B_{OP} . When the magnetic field is reduced below the release point, B_{RP} , the device output goes high (turns off). The difference between the magnetic operate point and release point is the hysteresis B_H of the device.

It is strongly recommended that an external bypass capacitor be connected in close proximity to the device between the supply and ground to reduce noise. The typical value of the external capacitor is 0.1 μ F.

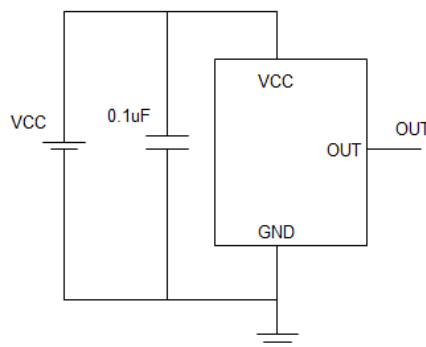

Package Information

Symbol	Dimensions In Millimeters			Dimensions In Inches		
	Min	Nom	Max	Min	Nom	Max
A	-	-	1.45	-	-	0.057
A1	0.00	-	0.15	0.000	-	0.006
A2	0.90	1.10	1.30	0.035	0.043	0.051
A3	0.60	0.65	0.70	0.024	0.026	0.028
b	0.39	-	0.49	0.015	-	0.019
c	0.12	-	0.19	0.005	-	0.007
D	2.85	2.95	3.05	0.112	0.116	0.120
E	2.60	2.80	3.00	0.102	0.110	0.118
E1	1.55	1.65	1.75	0.061	0.065	0.069
e	0.85	0.95	1.05	0.033	0.037	0.041
e1	1.80	1.90	2.00	0.071	0.075	0.079
L	0.35	0.45	0.60	0.014	0.018	0.024
L1	0.59REF			0.023REF		
L2	0.25BSC			0.01BSC		
θ	0°	-	8°	0°	-	8°

SOT23-3 Package

Symbol	Dimensions In Millimeters			Dimensions In Inches		
	Min	Nom	Max	Min	Nom	Max
A2	1.40	1.50	1.60	0.055	0.059	0.063
A4	0.75 TYP			0.030 TYP		
b	0.34	0.39	0.42	0.013	0.015	0.017
b1	0.40	0.46	0.50	0.016	0.018	0.020
C	0.37	0.40	0.42	0.015	0.016	0.017
D	3.90	4.10	4.20	0.154	0.161	0.165
E	2.90	3.05	3.30	0.114	0.120	0.130
e	1.27 TYP			0.050 TYP		
L	14.00	14.50	15.00	0.551	0.571	0.590

TO-92S Package

TMR Sensor Position

Top and side view (unit: mm)



MultiDimension Technology Co., Ltd.

Address: No.7 Guangdong Road, Zhangjiagang Free Trade Zone, Jiangsu, 215634, China

Web: www.dowaytech.com/en

Email: info@dowaytech.com

The information provided herein by MultiDimension Technology Co., Ltd. (hereinafter MultiDimension) is believed to be accurate and reliable. Publication neither conveys nor implies any license under patent or other industrial or intellectual property rights. MultiDimension reserves the right to make changes to product specifications for the purpose of improving product quality, reliability, and functionality. MultiDimension does not assume any liability arising out of the application and use of its products. MultiDimension's customers using or selling this product for use in appliances, devices, or systems where malfunction can reasonably be expected to result in personal injury do so at their own risk and agree to fully indemnify MultiDimension for any damages resulting from such applications.