

TMR7551-B

Unibody Precision Current Sensor

Description

TMR7551-B is a close loop current sensor for accurate measurement of DC, AC, pulsed current and arbitrary waveform current with galvanic isolation between primary and secondary circuits.

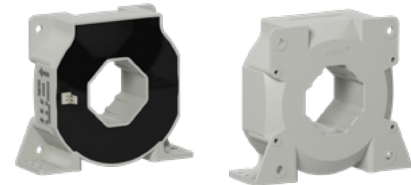

Features and Benefits

- High accuracy
- Excellent linearity
- Ultra low temperature drift
- Fast response time
- Galvanic isolation
- High immunity to external interference

Applications

- DC motor drives
- Inverter and variable frequency drives (VFD)
- Uninterruptible power supplies (UPS)
- Power supplies for welding application
- Switching power supplies

Selection Guide

Part Number	Primary Nominal Current	Primary Current Measuring Range
TMR7551-1001B	1000 A	±1500 A

Insulation and Environmental Characteristics

Parameters	Symbol	Typ.	Unit
Dielectric Strength	V_D	6.5	kV(50 Hz, 1 min)
Insulation Resistance	R_{IS}	1000	$M\Omega$
Creepage Distance	d_{CP}	15	mm
Clearance	d_{CL}	8	mm
Ambient Operating Temperature	T_A	-40 to +85	$^{\circ}C$
Ambient Storage Temperature	T_{STG}	-40 to +85	$^{\circ}C$
Mass	m	530	g

Catalogue

1. Specifications	03
2. Typical Output Characteristics.....	04
3. Typical Temperature Characteristics	05
4. Parameters Definition And Formula.....	06
5. Application Information	07
6. Dimensions	08

1. Specifications

$T_A = +25\text{ }^\circ\text{C}$, $V_{CC} = \pm 15\text{ V}$, $R_M = 5\text{ }\Omega$, unless otherwise noted

Parameter	Symbol	Condition	Min.	Typ.	Max.	Unit
General Electrical Data						
Primary Nominal Current	I_{PN}	TMR7551-1001B	-	1000	-	A
Primary Current Measuring Range	I_{PM}	TMR7551-1001B	-1500	-	1500	A
Sensitivity	S	$I_P = 0$ to $\pm I_{PN}$	-	0.2	-	mA/A
Number of Secondary Turns	N_S	-	-	5000	-	-
Output Current	I_{OUT}	$I_P = 0$ to $\pm I_{PM}$	-	$I_{OE} + S \times I_P$	-	A
Supply Voltage	V_{CC}	$\pm 5\%$	± 15	-	± 24	V
Current Consumption	I_C	$I_P = 0$	-	± 17	-	mA
Secondary Coil Resistance	R_S	$T_A = +25\text{ }^\circ\text{C}$	-	-	42	Ω
Measuring Resistance	R_M	For maximum measuring resistance value, please refer to Figure 2, 3, 4 and 5	0	-	-	Ω
Static Performance Data						
Accuracy	X_G	$T_A = +25\text{ }^\circ\text{C}$, $I_P = 0$ to $\pm I_{PN}$	-0.6	± 0.3	0.6	% I_{PN}
		$T_A = -40\text{ }^\circ\text{C}$ to $+85\text{ }^\circ\text{C}$, $I_P = 0$ to $\pm I_{PN}$	-1	± 0.5	1	
Linearity Error	ϵ_L	$T_A = -40\text{ }^\circ\text{C}$ to $+85\text{ }^\circ\text{C}$, $I_P = 0$ to $\pm I_{PN}$	-	± 0.1	-	% I_{PN}
Symmetry	ϵ_{SYM}	$T_A = -40\text{ }^\circ\text{C}$ to $+85\text{ }^\circ\text{C}$, $I_P = 0$ to $\pm I_{PN}$	99.5	100	100.5	%
Sensitivity Error	ϵ_S	$T_A = -40\text{ }^\circ\text{C}$ to $+85\text{ }^\circ\text{C}$, $I_P = 0$ to $\pm I_{PN}$	-0.8	-	0.8	%
Offset Error	I_{OE}	$T_A = +25\text{ }^\circ\text{C}$, $I_P = 0$	-	± 0.3	-	mA
Hysteresis	I_{OH}	$I_P = \pm I_{PN} \rightarrow 0$	-0.3	-	0.3	mA
Dynamic Performance Data						
Response Time	t_R	$di/dt > 50\text{ A}/\mu\text{s}$, 10% to 90% of I_{PN}	-	1	-	μs
Bandwidth	BW	-3 dB	DC	100	-	kHz

2. Typical Output Characteristics

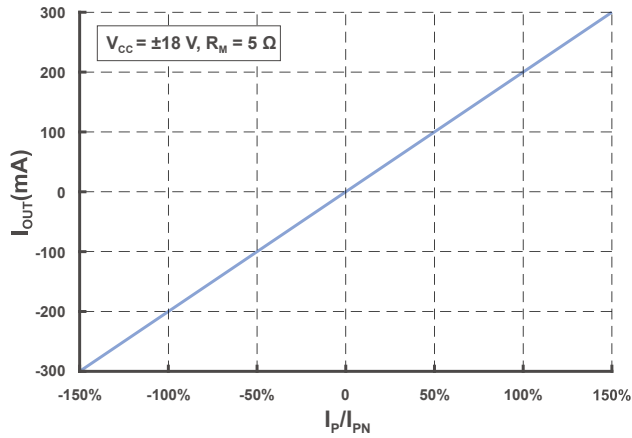

Figure 1. Output Voltage vs Primary Current

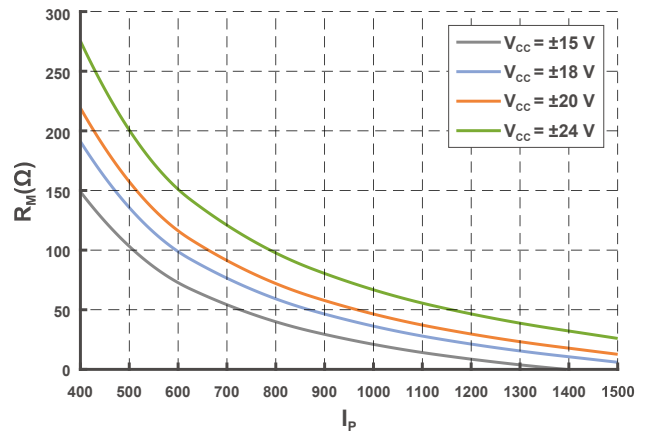

Figure 2. Measuring Resistance (@ $T_A = 85\text{ }^\circ\text{C}$)

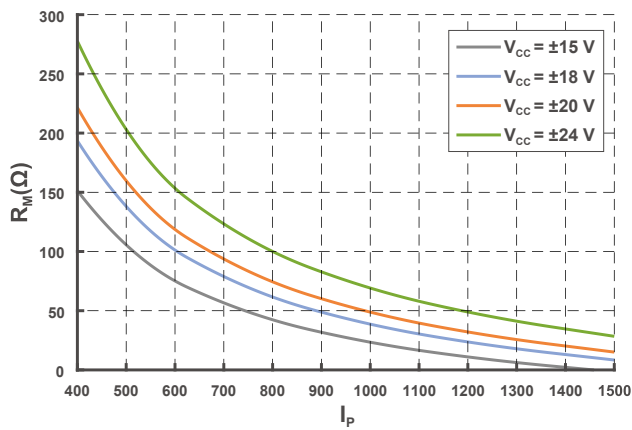

Figure 3. Measuring Resistance (@ $T_A = 70\text{ }^\circ\text{C}$)

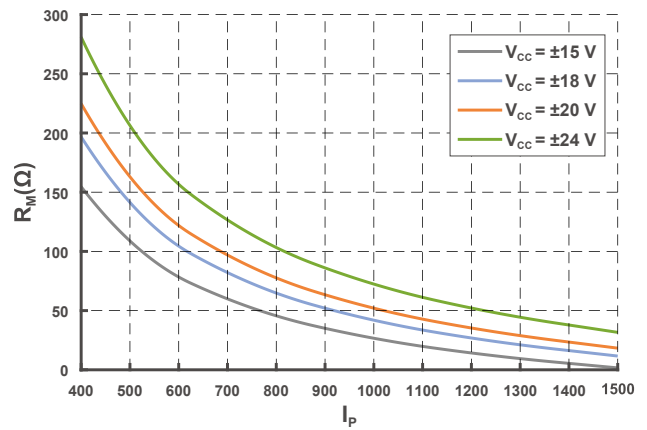

Figure 4. Measuring Resistance (@ $T_A = 50\text{ }^\circ\text{C}$)

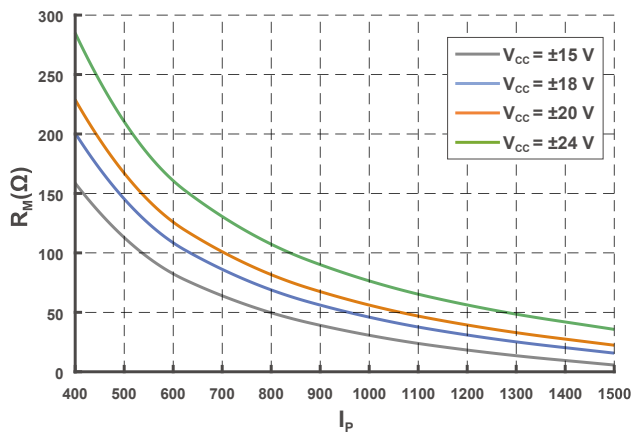

Figure 5. Measuring Resistance (@ $T_A = 25\text{ }^\circ\text{C}$)

3. Typical Temperature Characteristics

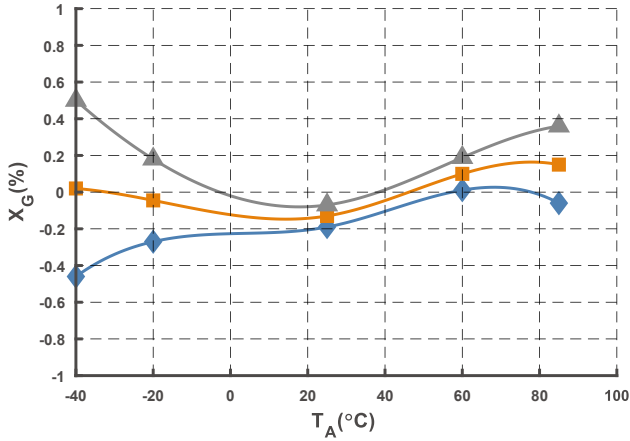

Figure 6. Accuracy

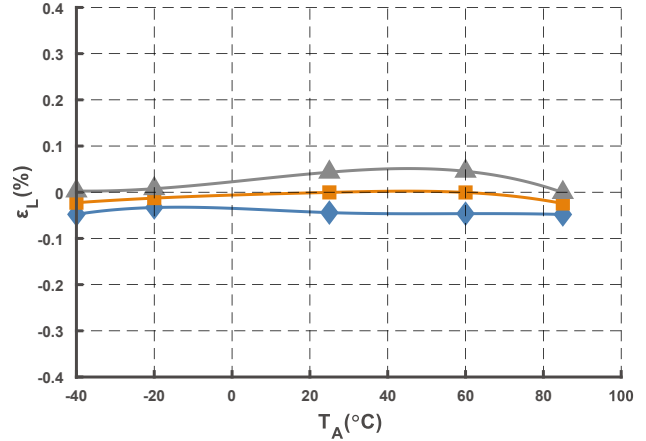

Figure 7. Linearity Error

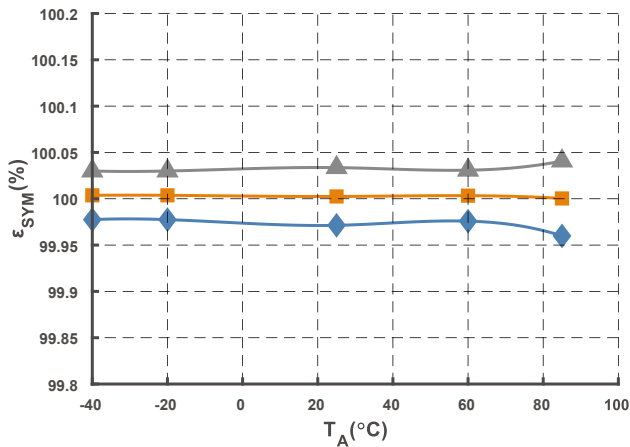

Figure 8. Symmetry

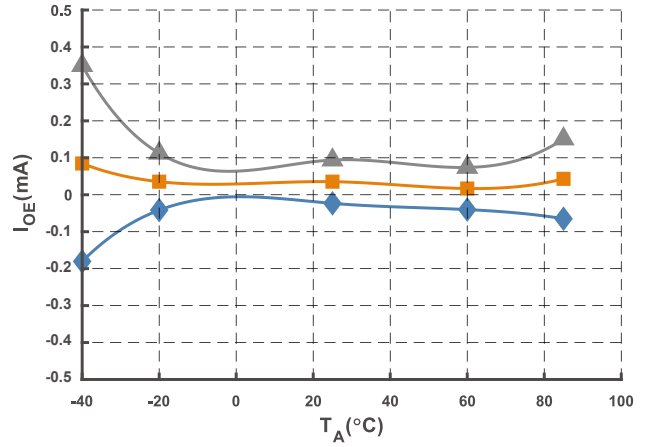

Figure 9. Offset Error

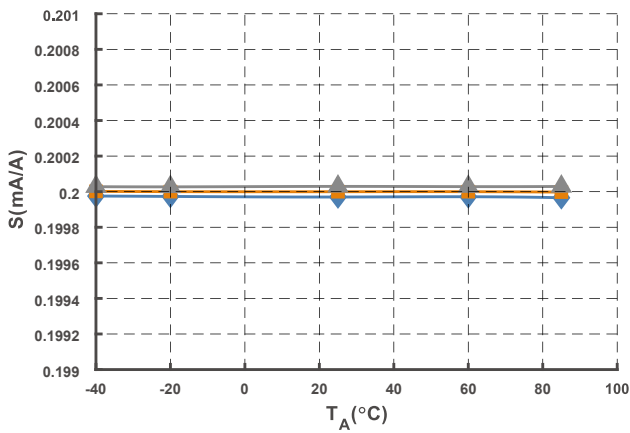

Figure 10. Sensitivity

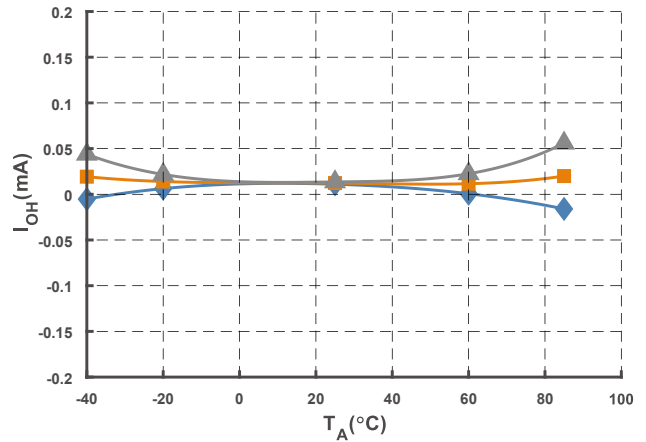

Figure 11. Hysteresis

4. Parameters Definition And Formula

1) Output Current

$$I_{OUT} = I_{OE} + S \times I_P$$

I_{OUT} stands for current sensor output current at given primary current, I_{OE} stands for offset error, S stands for sensitivity, I_P stands for primary current.

2) Accuracy

$$X_G = \text{MAX}_{I_P \in [-I_{PN}, I_{PN}]} \left(\frac{I_{OUT} - (S \times I_P)}{S \times I_{PN}} \times 100\% \right)$$

I_{PN} stands for nominal primary current.

3) Sensitivity

$$S = \frac{I_{OUT(@ I_{PN})} - I_{OUT(@ -I_{PN})}}{2 \times I_{PN}}$$

$I_{OUT(@ I_{PN})}$ and $I_{OUT(@ -I_{PN})}$ stand for the current output at I_{PN} and $-I_{PN}$ respectively.

4) Linearity

$$\varepsilon_L = \text{MAX}_{I_P \in [-I_{PN}, I_{PN}]} \left(\frac{I_{OUT} - (\bar{I}_{OE} + \bar{S} \times I_P)}{S \times I_{PN}} \times 100\% \right)$$

\bar{S} and \bar{I}_{OE} stand for the average values of the sensitivity and offset error.

5) Symmetry

$$\varepsilon_{SYM} = \frac{|I_{OUT(@ I_{PN})} - \bar{I}_{OE}|}{|I_{OUT(@ -I_{PN})} - \bar{I}_{OE}|} \times 100\%$$

6) Hysteresis

$$I_{OH} = \text{MAX } \Delta H$$

ΔH is the maximum residual output current between full scale positive and negative nominal current.

7) Measuring Resistance

$$R_{M \text{ MAX}} = N_S \times \frac{V_{CC} - 0.7V}{I_P} - R_S \times \frac{234.5 + T_A}{234.5 + 25}$$

$R_{M \text{ MAX}}$ is the maximum measuring resistance, N_S is the number of turns of the secondary coil winding and T_A stands for ambient operating temperature

5. Application Information

Electrical Connection

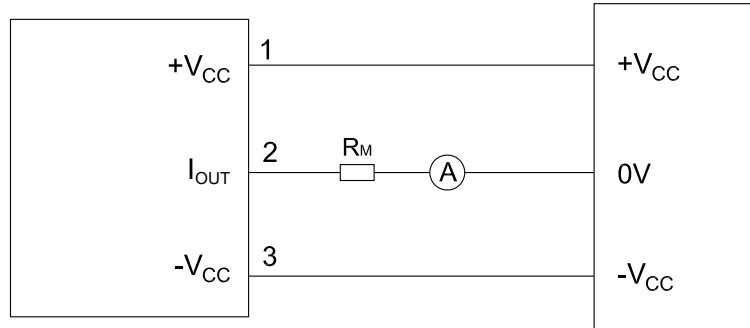

Figure 12. Electrical Connection

Mounting Recommendation

1. Mounting method: $2 \times \Phi 5.3$ mm holes
 $2 \times$ M5 copper or SS304 screws (Recommended torque 1.2 N·m)
Or
 $4 \times \Phi 4.2$ mm holes
 $4 \times$ M4 copper or SS304 screws (Recommended torque 1.2 N·m)
2. Primary through hole dimensions: $\Phi 38$ mm
3. Secondary electrical connection: Molex 22292031
Crimp Housing: Molex 22012031
Crimping Terminal: Molex 08550102

Remarks

1. I_{OUT} is positive when the primary current (I_P) is in the same direction as the arrow indication on the label and vice versa.
2. Improper connection may result in permanent damage of the sensor.
3. Excessive capacitive load may result in distortion of output signals when measuring high frequency primary signal. Please refer to Output Voltage vs Load Capacitance Curve.
4. Dynamic performances (di/dt and response time) are best with a single busbar completely filling the primary through hole.
5. Sensor is customizable upon request.

6. Dimensions

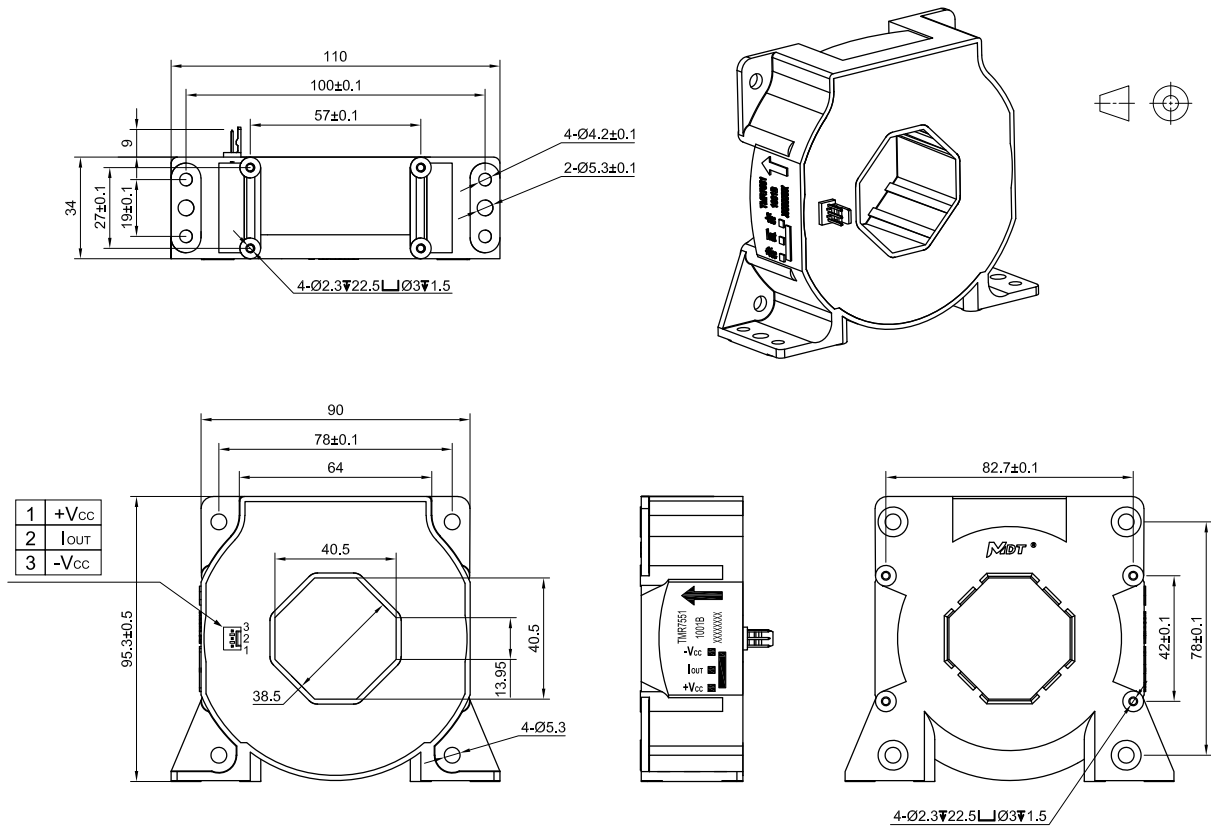

Figure 13. Dimension (unit: mm, tolerances for unmarked scales ±1 mm)

Copyright © 2024 by MultiDimension Technology Co., Ltd.

Information furnished herein by MultiDimension Technology Co., Ltd. (hereinafter MDT) is believed to be accurate and reliable. However, MDT disclaims any and all warranties and liabilities of any kind, with respect to any examples, hints or any performance or use of technical data as described herein and/or any information regarding the application of the product, including without limitation warranties of non-infringement of intellectual property rights of any third party. This document neither conveys nor implies any license under patent or other industrial or intellectual property rights. Customer or any third-party must further determine the suitability of the MDT products for its applications to avoid the applications default of customer or third-party. MDT accept no liability in this respect.

MDT does not assume any liabilities of any indirect, incidental, punitive, special or consequential damages (including without limitation of lost profits, lost savings, business interruption, costs related to the removal or replacement of any products or rework charges) whether or not such damages are based on tort (including negligence), warranty, breach of contract or any other legal theory. Notwithstanding any damages that customer might incur for any reason whatsoever, MDT's aggregate and cumulative liability towards customer for the products described herein shall be limited in accordance with the terms and conditions of commercial sale of MDT.

Absolute maximum ratings are the extreme limits the device will withstand without damage to the MDT product. However, the electrical and mechanical characteristics are not guaranteed as the maximum limits (above recommended operating conditions) are approached. MDT disclaims any and all warranties and liabilities of the MDT product will operate at absolute maximum ratings.

Specifications may change without notice.

Please download latest document from our official website www.dowaytech.com/en.

Recycling

The product(s) in this document need to be handed over to a qualified solid waste management services company for recycling in accordance with relevant regulations on waste classification after the end of the product(s) life.



No.2 Guangdong Road, Zhangjiagang Free Trade Zone, Jiangsu, China

Web: www.dowaytech.com/en E-mail: info@dowaytech.com

